

Catalogue and spare parts catalogue 2018/19

Blind rivets, blind rivet nuts and riveting tools

effective 1st May 2018



GESIPA®



Get quote 

Angic Global Solutions

1-888-872-0690

<https://www.AngicGlobal.com> Sales@AngicGlobal.com

6 good reasons for choosing GESIPA®

01 Engineering

Benefit from our experience starting from the development process. This allows you to free up your resources and reduce development costs.

02 System Solutions

Rivet technology at highest level - a brilliant way to optimise your production processes, save time and make more efficient use of your resources.

03 Parts Management

Working together with us allows you to reduce the number of parts and suppliers. At the same time, you lower your costs for C-parts, logistics and handling.

04 Guaranteed Worldwide Delivery

Trust in the worldwide availability of our services and products. With production facilities in Europe, USA and Asia we are close to you wherever you are so that availability of all parts is guaranteed at all times.

05 Quality

Your quality is in the focus. Assure your product quality by means of various quality control options as well as monitoring and documentation during the setting process.

Our strength is to develop profitable and bespoke fastening solutions. Free up your resources and cut development costs. While we care about the engineering part, you can concentrate on what is most important for your business: your products.

When deciding for system solutions by GESIPA® you decide in favour of rivet technology at highest level. With our complete system solution you achieve outstanding product quality. As positive side effects you optimise your production processes, save time and make more efficient use of your resources.

By using one multi-grip rivet instead of several different ones you can already optimise existing production processes. This also means reduced article stocks and lower handling and logistics costs.

In addition, the risk of mixing up fasteners in production will be minimised.

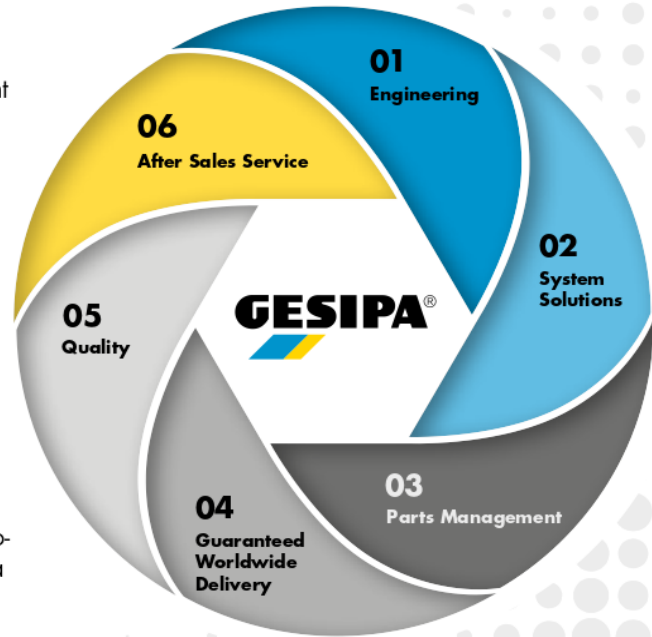

06 After Sales Service

Good connections are based on trust and understanding. We understand your needs, everywhere in the world.

GESIPA® operates at international level. Our production facilities in Europe, Asia and USA as well numerous sales agencies and trading partners all over the world guarantee availability of all parts - everywhere, at all times. Customer service is provided globally by qualified employees.

Focus on your products – with comprehensive quality control of our fasteners and various setting process monitoring options in production. Save costs when it comes to providing highest quality and ensure customer satisfaction.

Good connections to many of our customers for several decades show: those who trust each other and have a good relationship can achieve a lot together.

Customer ID

Your in-house representative

Telephone number

Or extension

Your field sales representative

Telephone number



Get quote »

Angic Global Solutions

1-888-872-0690

<https://www.AngicGlobal.com> Sales@AngicGlobal.com

Overview

Please find the detailed table of contents on page 4.

- 1  **Blind rivets**

- 2  **Cordless blind rivet setting tools**
Manual blind rivet setting tools
Battery-powered blind rivet setting tools

- 3  **Pneumatic blind rivet setting tools**
Hydro-pneumatic blind rivet setting tools

- 4  **Speed rivet technology**
Fasteners and setting tools

- 5  **Lockbolt setting tools**

- 6  **Blind rivet nuts**

- 7  **Cordless blind rivet nut setting tools**
Manual blind rivet nut setting tools
Battery-powered blind rivet nut setting tools

- 8  **Pneumatic blind rivet nut setting tools**
Hydro-pneumatic blind rivet nut setting tools

- 9 **DIY** **Do-it-yourself (DIY)**
DIY product range, mini packs of blind rivet,
mini packs of blind rivet nuts

- 10  **Spare parts**
Blind rivet setting tools
Blind rivet nut setting tools

- 11 **POS** **Point of Sale**
Profi (

Follow us on



www.gesipa.com
[youtube.com](https://www.youtube.com)



Get quote 

Angic Global Solutions 1-888-872-0690
<https://www.AngicGlobal.com> Sales@AngicGlobal.com

Contents



Useful information about **GESIPA®**



Blind rivet technology

1 Blind rivets

Blind rivets	30
PolyGrip®, coloured blind rivets, SolarGrip®, CAP®, special blind rivets, G-Bulb, PolyBulb, MEGA GRIP®, BULB-TITE®, TRI-FOLD®, Solid Riveting	46

2 Cordless blind rivet setting tools

Blind rivet hand tool	76
NTS, NTX, NTX-F, Flipper®, Flipper® Plus, HN 2, HN 2-BT, SN2	
Battery-powered blind rivet setting tools	88
Bird Pro series	88
iBird® Pro, AccuBird® Pro, PowerBird® Pro, PowerBird® Pro Gold Edition, PowerBird® Pro Gold Edition with spring-loaded trigger system	
Bird series	103
AccuBird®, PowerBird®, PowerBird® Solar	

3 Pneumatic blind rivet setting tools

TAURUS® series	118
TAURUS® 1-6	124
TAURUS® versions: TAURUS® 2/K, TAURUS® 2/AS, TAURUS® 2/24, TAURUS® 1-4 with counter device, TAURUS® 1-4 with counter device eco, TAURUS® 4 CF, TAUREX 1-6, TAURUS® 1-4 Axial eco, TAURUS® 1-4 Axial, TAUREX 1-4 Axial compact, TAUREX Axial 1-4, TAURUS® 1-4 C AV, TAURUS® WinTech	132
Hydro-pneumatic blind rivet setting tools	148
PH1, PH2, PH 2000, PH2 VK, PH Axial	
Automatic riveting machines	160
GAV 8000 eco, GAV 8000 electronic, GAV HF	
GESIPA®-assembly cell	172

4 Speed riveting technology

Fasteners: G-Speed®, Speed-Bulb®	178
Tools: TAURUS® 1 Speed Rivet, TAURUS® 2 Speed Rivet, TAURUS® 1 Speed Rivet Axial eco, TAURUS® 2 Speed Rivet Axial eco	187

5 Lockbolt setting tools

PowerBird® SRB 4,8, PowerBird® SRB 6,4, TAURUS® 3 SRB, TAURUS® 4 SRB	
TAURUS® 4 SRB with angle head 90° compact	

Contents



198

Blind rivet nut technology

6 Blind rivet nuts

Blind rivet nuts	208
Blind rivet nuts closed end (CAP®)	218
PolyGrip® blind rivet nuts	220
SoftGrip® blind rivet nuts	223
Blind rivet nut studs	226
PolyGrip® blind rivet nut studs splined	228
Blind rivet nuts with hose connection	229

7 Cordless blind rivet setting tools

Blind rivet nut hand tools	230
GBM 10, GBM 30, FireFly, Flipper® Plus	
Battery-powered blind rivet nut setting tools	242
FireBird® Pro, FireBird® Pro Gold Edition, FireBird®, FireBird® with conversion kit for blind rivet nut studs	

8 Pneumatic blind rivet nut setting tools

FireFox® 1 F, FireFox® 2 F, FireFox® 2, FireFox® 2 FL, FireFox® 1 F with conversion kit for blind rivet nut studs, FireFox® 2 with conversion kit for blind rivet nut studs, FireFox® 1 F Axial eco, FireFox® 2 F Axial eco, FireFox® 2 F Axial eco with contact pressure monitoring and counting device, FireFox® 2 C, FireRex®, FireRex® 2 C, GBM 95	254
--	-----



284

Do it yourself (DIY)

9 Blind rivet hand tools, accessories, assortments, blind rivet nut hand tools, Mini-Packs	284
---	-----



294

Spare parts catalogue

10 Blind rivet setting tools and blind rivet nut setting tools	294
---	-----



390

Point of sale

11 Profi Center, sales wall, in-house trade fairs	390
--	-----

GESIPA Blindniettechnik GmbH

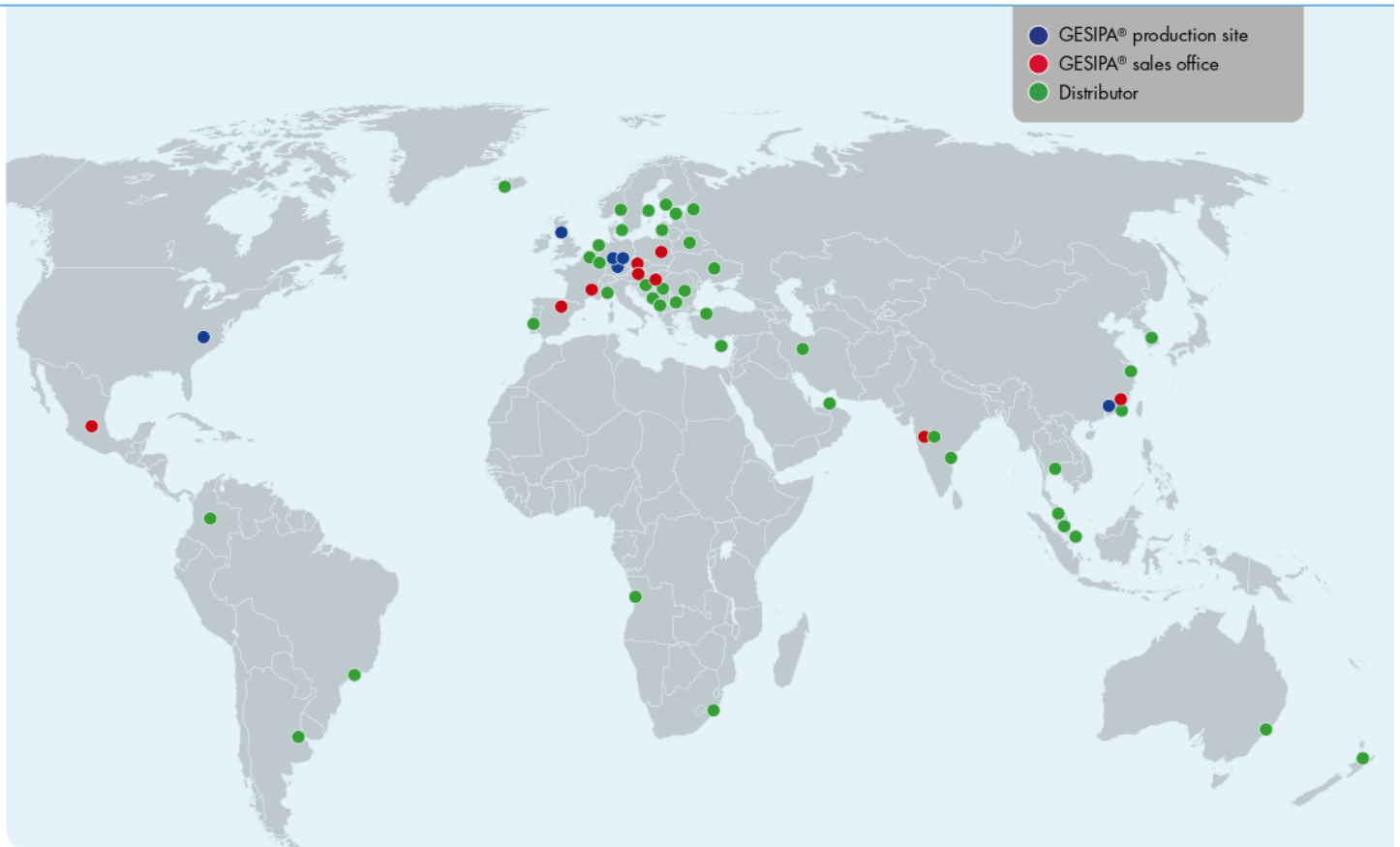

GESIPA® – A leading international company with six production sites worldwide inclusive three in Germany.

Founded in 1955 by Dr. Hans-Georg Biermann and his wife Ibeth Biermann, GESIPA Blindniettechnik GmbH has developed into a leading international company for blind rivet technology. The high quality and reliability of GESIPA® fasteners and the innovative, high-quality setting tools have made GESIPA® a valued partner to the trade and industry worldwide.

700 employees at six production sites throughout the world, including three locations in Germany, turn out high-quality and innovative products day after day with dedication and passion.

Foreign sales are handled by twelve subsidiary companies and more than forty foreign representatives.

Family-owned up to the end of 2008, GESIPA® is now part of the international company SFS intec AG, and as such well prepared to meet the future challenges imposed by its partners in trade and industry with new ideas and solutions.

CUSTOMER PROXIMITY and FLEXIBILITY are certainly given top priority at GESIPA®.



GESIPA Blindniettechnik GmbH

As one of the last companies producing fastener technology in Germany, GESIPA® remains absolutely loyal to the specialist trade. The comprehensive external sales force provides expert advice on all questions relating to blind rivet technology, while the internal sales and despatch personnel guarantee smooth working processes and fast, reliable delivery.

The Technical Sales team with its five business units **Distribution & Retail (R-DR), Equipment Manufacturer (R-EM), Industrial Applications (R-IA), Automotive Riveting (R-AR)** and **Solid Riveting (R-SR)**, advises and looks after the demanding requirements of domestic and international industry customers. The technically and economically optimum solutions are developed together with developers, production planners and quality specialists.

Two of the largest industrial customer groups of GESIPA® are the automotive industry and automotive subsuppliers, which both place stringent demands on reliable and economic fastening solutions.

The readiness for innovation and creativity of all employees contribute to long-term customer satisfaction and partnership cooperation, in order to consolidate and extend the market leadership of GESIPA®.

In the product group of setting tools, decisive market leadership is ensured by forward-looking products such as the GAV riveting machines, the steadily developed battery-powered blind riveting tools with the new tools of the pro series, the TAURUS® series and the FireFox® 1 F and 2 blind rivet nut setting tools.

Innovative fasteners such as PolyGrip®, PolyBulb®, G-Bulb structural rivet and BULB-TITE® blind rivets, originally developed for industry and the construction sector, also demonstrate their advantages outstandingly in other markets.

Reliability and consistent performance, demonstrated millions of times, is achieved by GESIPA® through its vast experience in production, gained over many years, and a quality concept which is unique in the sector.

Highly qualified employees, the best production machines and the in-production quality organisation guarantee fulfilment of even the most demanding customer requirements. In addition to the checking of dimensions, tolerances and quality of the raw materials, finished products are also submitted to extensive functional checks before they leave the works. All GESIPA® products comply with the RoHS 2011/65/EU directive.

All German GESIPA® production locations operate a quality management system certified to DIN EN ISO 9001 and ISO TS 16949.



GESIPA®-Business Units



BU R-DR
Jörg Penzel

BU R-IA
Patrick Cezanne

BU R-SR
René Müller

BU R-AR
Sebastian Hahn

BU R-EM
Uwe Herth

GESIPA® – Application-optimised and cost-effective joining solutions

GESIPA® riveting technology focuses on five customer segments. The top priority is the direct relationship with the customer and his specific requirements with the aim of designing application-optimised and cost-effective joining solutions.

BU Distribution & Retail (R-DR)

Traditionally, GESIPA® works closely with specialist retailers. The business unit Distribution & Retail maintains a comprehensive field service both in the domestic and global markets, providing competent service in all aspects of blind riveting. The support ranges from consulting and training on-site to regular participation at trade events, for example in-house trade fairs. By means of sales stands such as the well-known Profi Centre, GESIPA® provides the

retail business with effective sales aids. Furthermore, the GESIPA® sales representatives have recourse at all times to the expertise and support from the other GESIPA® Business Units.

BU Equipment Manufacturer (R-EM)

The business unit Equipment Manufacturer is divided into Equipment and Service Technology divisions. By specialising in the two product areas of "fully automatic blind riveting" and "process monitoring", customer requirements and technical demands are precisely analysed with the aim of jointly developing technically optimised and economically viable solutions. The Service Technology division is responsible for equipment commissioning on site, after sales service as well as maintaining system availability at the customer.

GESIPA®-Business Units

BU Industrial Applications (R-IA)

The business unit Industrial Applications specialises in selected segments in general industry where comprehensive know-how in specific sectors can generate additional customer benefits. Switchgear engineering, air conditioning systems, building installations as well as storage facilities are just some of the many areas, in which BU R-IA is active. In line with GESIPA® philosophy, the main attention is focused on application-oriented procedures. The vast experience, extensive technical know-how and specialist expertise in selected sectors sustainably enhance customer advantages. The customer benefits from a range of joining elements tailor-made to suit his specific requirements as well as comprehensive advice in selecting the most suitable equipment for the job. Special emphasis is always placed on the complete system, consisting of joining elements, riveting equipment and joining method, with the aim of creating the most cost-effective and efficient solution for the customer. Customer segmentation is systematically expanded in domestic and international markets, thus consolidating customer relations in the long term.

BU Automotive Riveting (R-AR)

Motor vehicle manufacturers and suppliers to the automobile industry with their diverse range of demands are looked after by the business unit Automotive Riveting. Since the individual demands give rise to very specific requirements, the BU is further subdivided into areas Seating, Door Modules and Safety Parts. The renowned, technologically leading key customers who challenge and thus also decisively advance GESIPA® are looked after by highly qualified Key Account Managers.

BU Solid Riveting (R-SR) (W+O)

The Business Unit Solid Riveting based in Olpe, North Rhine-Westphalia, produces solid, semi-tubular rivets and cold-formed parts manufactured almost exclusively to customer drawings. The BU's core market is the German automobile and commercial vehicle industry. Frame rivets with a specially developed anti-corrosion coating, the so-called SheraBlack® coating, are produced specifically for the commercial vehicle sector, for example for Daimler Trucks. But more complex cold-formed parts for Tier One suppliers are also an important market for the BU Solid Riveting.

GESIPA®-Business Units	Distribution and Retail (R-DR)			
	Equipment Manufacturer (R-EM)			
	Industrial Applications (R-IA)			
	Automotive Riveting (R-AR)			
	Solid Riveting (R-SR)			

GESIPA®-Service*

GESIPA® – Comprehensive range of services from under one roof

01 Maintenance & Servicing Agreements

Regular servicing and maintenance are required to ensure processes and production runs smoothly. Servicing and maintenance are the foundation for guaranteeing high availability of your production facilities where downtimes are minimised, thus keeping costs down. These procedures also increase operational safety thereby protecting your personnel.

02 Technical Talks

Whether in our Demonstration Center, on your premises or at conferences: when it comes to selecting the venue and time we are really flexible. Talks aimed at specific target groups are of course no problem.

03 Training

We hold training courses for our customers' staff at our training centres or, if required, on site. The innovative training programme includes training courses on equipment, GAV systems as well as foundation and advanced courses.

04 Commissioning

Following the installation of a machine, comprehensive customer service is provided by our resourceful service team. The service team carries out both the commissioning as well as the maintenance of the machine.

05 Replacement Equipment Hire (GESIPA® special models)

To ensure your production process keeps running smoothly we stock a range of equipment for hire. You can make use of this equipment in maintenance and repair phases. Or when your own equipment pool is unable to deal with peaks in orders. We are here to help!

06 Factory Calibration

Process-monitored riveting tools are calibrated based on applicable test standards as part of the Gesipa calibration service. The calibration standard used is verified by routine test equipment monitoring. We can also carry out the calibration procedure directly on your premises.

07 Firmware Update

Firmware updates are available on request to keep your processing systems up-to-date, making sure they operate reliably safely and efficiently at all times.



08 Repair Service

GESIPA® processing tools are manufactured to the highest quality standards. However, should repairs ever become necessary our technicians will provide fast and reliable assistance. The benefits of the GESIPA® repair service:

- Repair by qualified technical personnel
- Use of genuine spare parts
- Safety check after every repair
- Retain the warranty and tool availability

09 Initial Sample Inspection (PPAP, VDA 2)

Initial sample inspection verifies that, prior to the start of series production, the customer requirements agreed upon in the specification as well as other requirements (e.g. legislation, standards) in terms of the product and process are met. The same also applies to the annual re-qualification

10 Worldwide Service

Over 700 members of staff at six production sites worldwide – three of which in Germany – produce with commitment and passion high quality and innovative products. Sales abroad are handled by 12 subsidiaries and more than 40 international representatives.

*These services vary specific to country and are based on the service programmes available at the Waldorf/Germany site.

No faults. Flexible processes. Highest quality.



Precision monitoring of processes with GESIPA® and Sarissa®

QualityAssist / PositionBox

Sarissa assistance systems fit perfectly in an interlinked production environment. As defined by Industry 4.0, the PositionBox and QualityAssist provide exact, quality-related location information. The LPS* communicates via a TCP/IP link and with a real time data protocol with higher level controllers, irrespective of whether PC or PLC. The LPS* can be controlled remotely with powerful commands. In this way the production controller is able to compile work instructions from basic information in real time.

The result: highly flexible control of product manufacturing processes according to customer requirements, true Batch Size One production. Human errors of neglect, omission, and confusion are no longer possible. In order to connect tools, the LPS* has four open-protocol interfaces. Modbus-TCP to digital inputs and outputs completes the communication options. For remote assistance or maintenance, the second network interface can be used with TeamViewer®.

For further information: www.sarissa.de/en/

Advantages

- Reduction in assembly costs
- No final inspection
- Reduction of complaints
- High customer satisfaction
- Zero error rate through „Zero Default System“

*Local Positioning System

The Sarissa Local Positioning System (LPS) combines advanced ultrasound technology, easy-to-use software and a powerful, open interface architecture. It can be used as a high-performance, highly flexible assistance system or as a pure 3D coordinate supply for automation technology.



DURABILITY OF GESIPA® TOOLS

**Resource
Human**



TAURUS®



Health

- Economic compressed air consumption thanks to dual action: rivet setting and spent mandrel evacuation
- Jaws (main wearing part) with patented mechanism for much longer service life than the competition
- Modular principle for light-weight tools and most efficient solutions
- Ergonomically beneficial angle of 12° between handle and riveting direction
- „VAS“ evacuation for substantially reduced compressed air consumption
- Noise emission: integrated silencer

Ergonomics



**Energy-
saving**

GAV



- Large components are virtually wear-free. Even after completing 11 million operations, the assemblies of the GAV HF are still running efficiently on a customer's production line
- Short cycle time and high availability
- Suspension on the balancer ensures ergonomic and smooth operation when the tool is manually guided by the operator and ergonomically designed handle system for effective tool handling
- The only fully automated riveting system in the world





Manual setting tools

- Soft and ergonomically designed handles
- PVC-free material



Battery-powered setting tools



- Power recovery while braking: Energy is used multiple times, thus extending the service life of the battery while preventing the tool heating up (Pro Series)
- Service life of the jaws as the main wearing part much longer than the competition
- Ergonomically designed handle with soft surface („2C housing“, Pro Series)
- Ergonomically beneficial angle of 12° between handle and riveting direction (Pro Series)
- Fast return => increased productivity, faster, less wear, reduced battery consumption, longer battery life, reduced tool servicing
- Less noise due to shorter process run times

Batteries

- Battery weight reduced by almost half
- Intelligent battery management system with extremely low closed-circuit current consumption

Efficiency

Resource-conserving



Catalogue guide

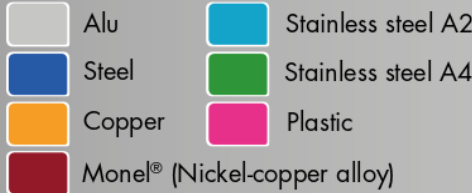

Blind rivet materials



Video



Product information

QR-codes / videos

When it comes to current developments, GESIPA® has its finger on the pulse – scan the QR codes to receive more information or watch videos about products. All you need is a smartphone, a tablet PC or a laptop with an integrated camera as well as the appropriate software designed to read QR codes.



Page reference

This symbol refers to the page number.



in accordance with ETA approval
ETA-13/0255

CE marking

The EU Construction Products Regulation (CPR) No. 305/2011 came into effect in June 2013. The approved products in our catalogue are marked with the CE symbol. The relevant approval documents can be found in the download area at www.gesipa.com.



New features

This symbol identifies new features.

MT

Abbreviations

MT The abbreviation **MT** is used in the blind riveting field to indicate material thickness.



Availability

This product is made to order. Contact our Customer Service for detailed information on availability.

Spare parts catalogue

Please note that for technical reasons the numbers in the technical drawings may change. We therefore recommend that you always use the part numbers when ordering spare parts.

More dimensions and Types available on request.

We reserve the right to make changes for the entire catalogue. We do not accept liability for errors or misprints. All prices specified are net prices. The value added tax is invoiced separately.

The applicable terms and conditions of guarantee shall apply and can be viewed under following link:

www.gesipa.com/agb

GESIPA®'s new products

NEW

iBird® Pro



Includes app
P.90

TAURUS® C AV



Now with
closed support
sleeve!
P.146

Protective sleeve



The rubberised coating protects sensitive workpieces
P.128

Flipper® Plus



Combi setting tool
for blind rivets and
blind rivet nuts!
P.84

P.223

Blind rivet nut SoftGrip®



THIS IS NEW



GESIPA®'s new products

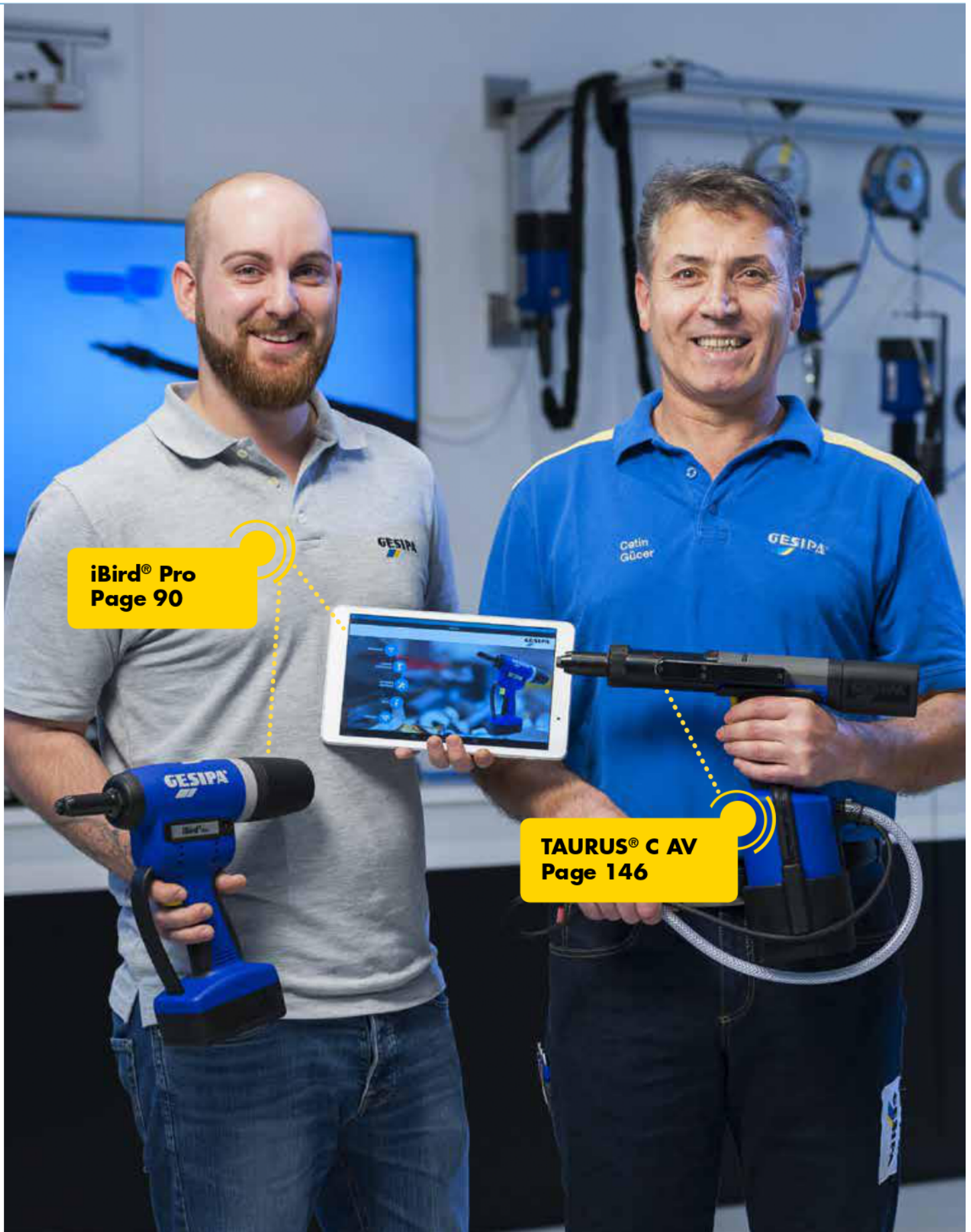

NEW



**Flipper® Plus
Page 84**

**Protective sleeve
Page 128**

GESIPA® – The special blind rivet



GESIPA® always manufactures with state of the art technology. You can rely on GESIPA®-quality. Challenge us!

Perfect products are secured by continuous investment in staff qualification and production machinery. Permanent controls during manufacturing guarantee outstanding setting characteristics and a firm hold, batch after batch after batch...

Better than the standard

The location of the mandrel break-points in GESIPA® blind rivets is matched to the body length in such a way that the setting tool needs only to be triggered once to set the rivet and extract the spent mandrel, no matter how long the body is. GESIPA® rivets also have a longer mandrel than other rivets as a standard, so that nosepieces extended by up to 10 mm can be used without any problem.

A clean solution

GESIPA® blind rivets are thoroughly cleaned and fitted with high-quality, bright-galvanised mandrels. Soiling of the tool's jaws is minimised, thus extending significantly the service life of the setting tools.

Great connection

GESIPA® blind rivets always produce a high-quality and visually attractive finish thanks to their matched geometries and the high-quality materials of the individual components.

Fast and flexible

As a convenience for our customers, GESIPA® stocks a wide range of blind rivets, which includes all standard dimensions as well as 'rarities'. Our repair department deals with repairs specifically for you – all to GESIPA® high quality standards.

Perfect interaction

GESIPA® blind rivets and GESIPA® setting tools are perfectly matched to each other and use of the correct nosepiece will produce the perfect finish. GESIPA® setting tools offer minimal wear, short working cycles and a long service life, thereby guaranteeing minimum costs.

63 years of experience

Since 1955, GESIPA® has concentrated on creating the greatest possible customer benefits with the GESIPA® blind rivet and GESIPA® setting tools. 63 years of experience, which fully reflect in our products.

In the best hands at GESIPA®...

Special challenges in industry demand special solutions with regard to efficiency, function and innovation. GESIPA® has decades of experience in consultancy and development of blind rivets for specific applications. Requirements such as surface treatments, appropriate shear strength and/or tensile strength and setting process reliability are defined by Technical Sales according to the project, and guarantee millions of consistent quality fastenings.

Quality

From the traceability and documentation of the raw materials to the checking of dimensions and tolerances during production, GESIPA® attaches the greatest value to quality. But GESIPA® also goes one decisive step further. For blind rivets for specific applications, thorough functional tests are carried out and documented step-by-step.

Functional test / setting curve

For every production batch of blind rivets for specific applications, the setting curve is measured on a sophisticated test bench. The measured results of shaft deformation, insertion characteristics, mandrel shear load and tensile force are compared with the target values in order to ensure that the blind rivet forms as intended in the application and produces a secure fastening.

Function tests/ mandrel push-out force (1)

The remaining part of the mandrel enclosed in the set rivet is pushed out. The measured force can be used to determine whether the remaining part of the mandrel is properly locked and will not cause any rattling noises or even fall out. The batch is only released if both these values are within tolerance.

Monitored process – Reliable connection (2)

Safety relevant processes in the industrial use of blind rivets make 100% reliability of riveting operations essential. Process-monitored GESIPA® tools of the TAURUS® series and the fully automatic GAV 8000 riveting machine enable economic application solutions, from the basic system to systems with barcode scanners and process computers.

One fastener for several applications

The versatility of GESIPA® fasteners often means that several application cases which previously required different fasteners can be served by a single specially designed blind rivet. This saves costs and simplifies handling.

Cost advantages at a glance

- Reduction of downstream quality costs due to GESIPA® setting process monitoring
- Reduction of wearing parts costs due to identical parts strategy and modular design of the tools
- Reduction of logistics costs due to multi-functionality of the fasteners and corresponding reduction of parts diversity.

(1)

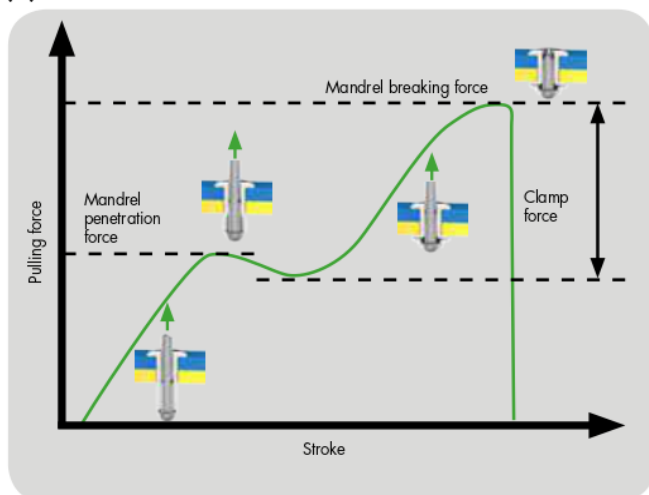

(2)

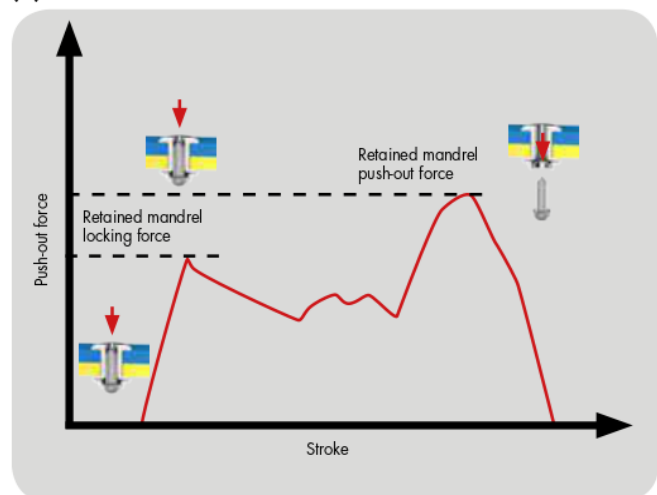

Construction approvals



More than 200 sizes of blind rivets produced by GESIPA® now meet the requirements and assessment guidelines of the European Technical Approval

In June 2013, the EU Regulation No 305/2011, laying down harmonised conditions for the marketing of construction products, came into force. A large number of our blind rivets are used for construction products. In order to comply with the new EU Regulation on construction products we have chosen more than 200 blind rivet sizes which meet the requirements and assessment guidelines of the European Technical Approval, thus being allowed to carry CE marking.

A European Technical Approval (ETA) for a construction provides proof of its fitness for an intended use according to the Construction Products Directive.

When the ETA has been granted, the manufacturer is allowed to place CE marking on his products.

The CE marking confirms that all evidence has been provided, all required assessments have been made and all requirements been met. The manufacturer herewith shows that his products complies with ETA requirements and guidelines.

In our catalogue the CE mark has replaced the Ü mark, providing evidence of product conformity for our newly approved blind rivets from the very beginning.

On the following pages the approved products are identified by the CE mark.

**ETA-Approval
applied for
ETA-13/0255**

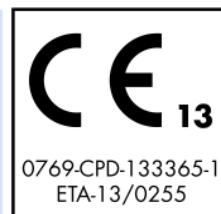

The respective approval documents are shown and can be downloaded on our website www.gesipa.com/en

For further questions please contact our quality assurance team who will be happy to help you.

Corrosion protection and watertightness

Our fasteners provide corrosion protection and watertightness to various extents depending on the material chosen. The features of the individual fasteners are shown in the following tables:

Category	Water tightness	Corrosion resistance
Standard blind rivets		
Alu/Steel		••
Alu/Stainless steel		•••
Alu/alu		•••
Steel/Steel		•
Copper/Steel		••
Copper/Bronze		•••
Stainless steel/Stainless steel		••••
Monel®		••••
Stinox		••
PolyGrip® blind rivets		
Alu/Steel	*•	••
Alu/Stainless steel	*•	•••
Steel/Steel		•
Stainless steel/ Stainless steel		••••
Monel®		••••
SolarGrip® with (SolarSeal-coating)	*•	••••
CAP® blind rivets		
Alu/steel	*	••
Alu/stainless steel	*	•••
Stainless steel/ stainless steel	*	••••
Copper/steel	*	••
Copper/stainless steel	*	•••
Special blind rivets		
Painted blind rivets alu/steel		••
Painted blind rivets alu/stainless steel		•••
Grooved blind rivets alu/ steel		••
Blind rivets thread Steel/Steel		•
Plastic blind rivets (Polyamide)		••••
Peel blind rivets alu/steel		••
Profile clinching rivets alu/ steel		••

Category	Water tightness	Corrosion resistance
High strength structure blind rivets		
G-Bulb steel/steel		•
G-Bulb Stainless steel/ stainless steel		•••
MEGA GRIP® alu/ alu	*•	••
MEGA GRIP® steel/steel	*•	•
Folding Type blind rivets		
BULB-TITE® blind rivets alu/alu	*	••
BULB-TITE® blind rivets steel/steel	*	•
BULB-TITE® blind rivets monel®/stainless steel		••••
TRI-FOLD® blind rivets alu/alu		••
Standard and PolyGrip® blind rivet nuts		
Alu		•••
Steel		•
Stainless steel		••••
Monel®		••••
Blind rivet nut studs		
Steel		•

- * Fastener is watertight
- * Joint is watertight when a washer is used
- *• Splash-proof

- low
- middle
- high
- very high

Further sizes, special surface treatments or materials are available upon request.

Blind rivet technology

- » **trust**
- » **move**
- » **know**
- » **understand**
- » **create**

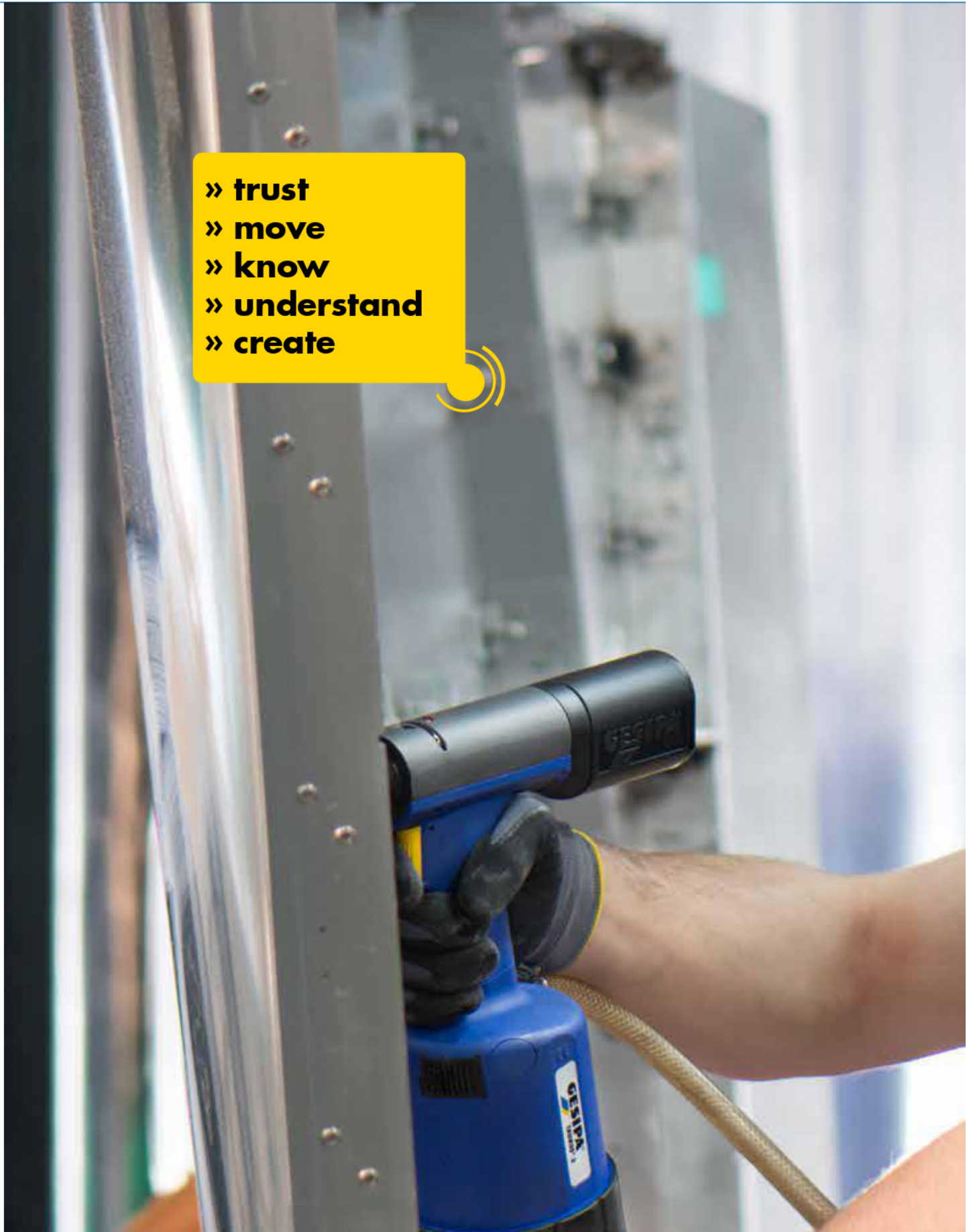



Technical data on GESIPA® blind rivets



GESIPA® blind rivets provide a lasting and safe joint for diverse and sensitive materials.

GESIPA® blind rivets – Efficient technology

Life without blind rivet technology from GESIPA® can no longer be imagined in modern industry production where fastening technology is required due to its efficiency and versatility. It combines the advantages of overcoming restricted component accessibility, permanently safe connection of different, and specialised materials, and even documentation of the setting process if required.

Technically speaking, the blind rivet consists of two parts: the rivet body and the mandrel. During screw-connecting, clinching and punch riveting etc. the application must always be accessible on both sides but the special thing about blind riveting is that the application only needs to be accessed from one side.

GESIPA® blind rivets – Connections that last

During the setting process, the mandrel is pulled by the jaws of the setting tool and forms the rivet body to the predefined fixed position in the application. The mandrel then breaks off at the intended point (the target breakage point) and can be recycled. The filling cut (this is the remaining rest of mandrel in the rivet body) can provide an additional securing function depending on the application.

GESIPA® blind rivets – For every application

Blind rivets are available in a variety of designs, materials, forms, lengths and even colours. Depending on the task which the blind rivet should fulfil, GESIPA® can choose between a standard model available from stock or a blind rivet specially designed for the application.

GESIPA® blind rivets – A rule of thumb

**Material thickness + rivet diameter
= rivet body length**

Technical data on GESIPA® blind rivets

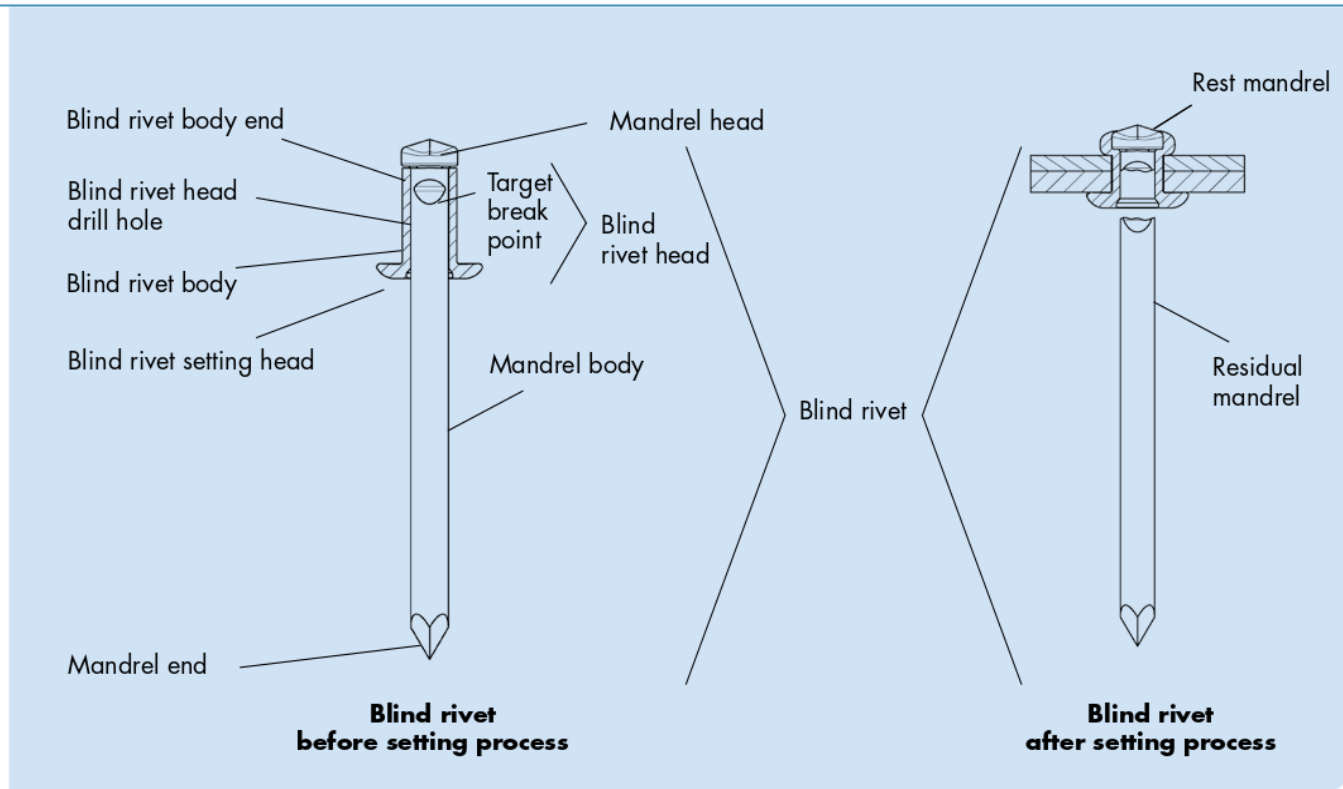

GESIPA® blind rivets – Concepts

- The blind rivet consists of two parts: the **rivet body** and the **mandrel**.
- The rivet body consists of the setting head and the shaft.
- The setting head is found on the processing side and is variable in diameter and shape. There are dome, countersunk and large flange versions. The rivet body is available in different lengths depending on the material thickness to be riveted.
- The rivet mandrel is used to deform the rivet body. It contains the predetermined breaking point. This is where the rivet mandrel breaks after the rivet has deformed.
- The rest mandrel is the remaining part of the rivet mandrel in the rivet body. The residual mandrel is the part of the rivet mandrel that is disposed of from the set rivet via the blind rivet setting tool.



The application-specific **GESIPA®** fastening more than just a standard blind rivet

The basic features of the standard blind rivet are defined by various DIN EN ISO standards. These features primarily involve the geometric dimensions and mechanical properties. Other fastener properties, such as the choice of material and surface coating, are defined very generally by the standards and are left up to the manufacturer.

These specifications about the blind rivet features seriously limit the tolerances of the connection parameters and the feasible requirements. Blind rivets that comply with DIN EN ISO standards are always designed for fixed parts

Customer requirement	GESIPA® solution
Adaption to rubber, wood, plastic and other materials	Definition of max. / min. tightening value or clamping force
Watertightness	Material + stamping + coating
Accessibility problem	Extended nosepiece in combination with a rivet mandrel extension
Corrosion resistance	Through organic and inorganic surfaces e.g. Zn, ZnNi, Delta Seal, stainless steel A2 and A4 or Monel®
No noise	Monitored rest mandrel locking
Tolerance compensation	Borehole diameter larger than DIN
High device and system availability	Device and fastener matched to each other, GESIPA®-general system

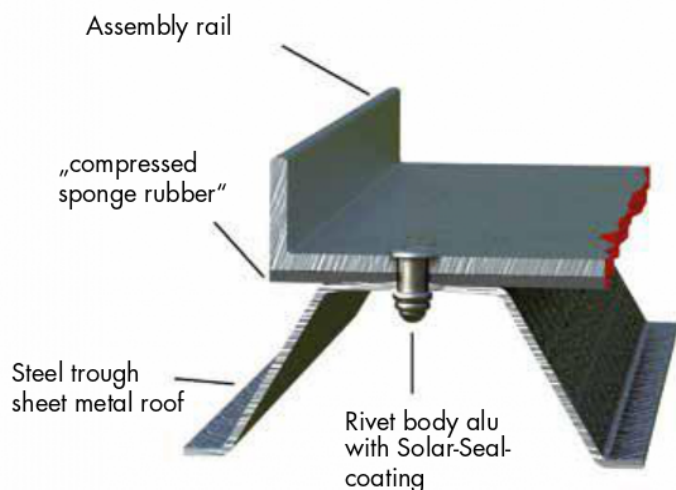

The application-specific fastener can be used for a larger number of tasks and satisfy higher requirements thanks to the targeted specification of the material, surfaces, geometric dimensions and in particular the functional properties. For example the following customer requirements can be satisfied:

- Elimination of access problems to rivet positions
- Adaptation to corrosion requirements to ensure higher resistance to environmental influences
- Production of splashwater protected joints whilst maintaining good mechanical properties
- Compensation of larger fluctuations in the part parameters
- Adaptation of the mechanical connection properties to the various joining materials

Typical requirements on setting process monitoring

Requirement	Possible monitoring criteria
Was a blind rivet processed in the application?	<ul style="list-style-type: none"> Monitoring of the spent mandrel evacuation Use of devices with spring loaded trigger system
Where all blind rivets processed for the application?	<ul style="list-style-type: none"> Monitoring and counting of the spent mandrels Use of devices with spring loaded trigger system
Was the right blind rivet processed?	<ul style="list-style-type: none"> Monitoring of the mandrel break force Use of devices with spring loaded trigger system
Was the defined connection quality achieved at this blind rivet point?	<ul style="list-style-type: none"> Monitoring of the break force and path/time



Speak to our technical sales

We offer technical support in the field of fastening technology. This gives you an advantage in terms of efficiency and quality because you always use the correct fastener. We are also able to meet customer requirements thanks to our years of experience in the fastening technology field.



Blind rivet range

- » **multifunctional**
- » **resistant**
- » **application-specific**





The experts in



Get quote 

Angic Global Solutions

1-888-872-0690

<https://www.AngicGlobal.com> Sales@AngicGlobal.com

Overview of the **GESIPA®** blind rivet product range



32

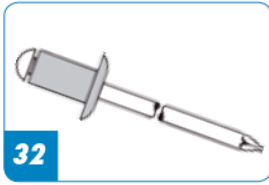

32

Alu

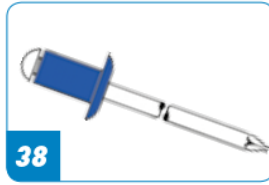

38

Steel

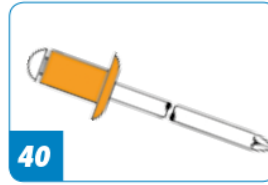

40

Copper

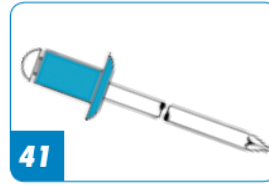

41

A2 stainless steel

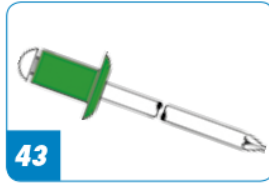

43

A4 stainless steel

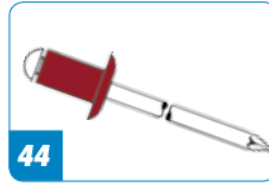

44

Monel®

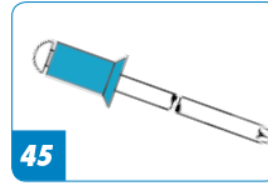

45

Stinox

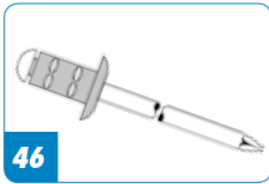

46

PolyGrip®

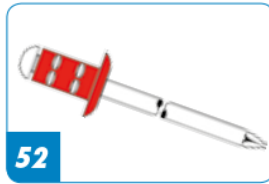

52

Coloured PolyGrip®

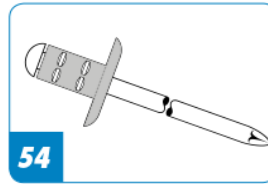

54

SolarGrip®

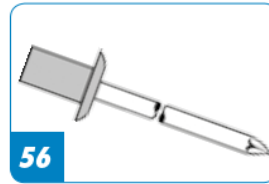

56

CAP®



60

Grooved

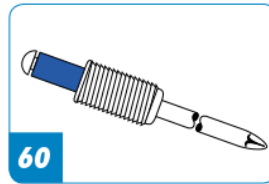

60

Threaded

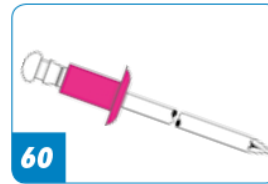

60

Plastic

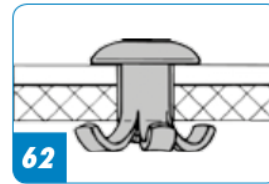

62

Peel

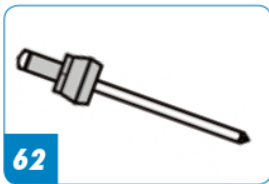

62

Profile clinching

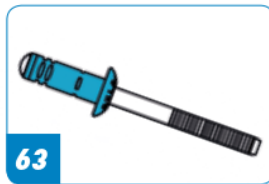

63

G-Bulb



66

PolyBulb®

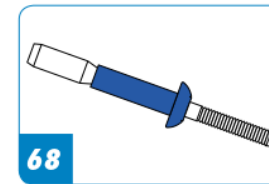

68

MEGA GRIP®



70

BULB-TITE®



74

TRI-FOLD®



75

Solid Riveting

Blind rivets – field of application



Standard

The right materials and size for every application



PolyGrip®

Large grip range can replace up to five different sizes of standard DIN blind rivets



CAP® blind rivet

Cup-type blind rivet for air- and watertight connections



Grooved blind rivet

For riveting blind holes, e.g. in wood or soft materials



Plastic blind rivet

Non-corroding, electrically non-conductive, no damage to painted surfaces



G-Bulb MEGA GRIP®

High-strength fastener



PolyBulb®

Large grip range, for soft materials



TRI-FOLD® folding type blind rivet Peel blind rivet

For soft materials



BULB-TITE®

Weatherproof multi-function valve folding-type blind rivet



Blind rivets alu/steel

Standard (Dome head)

Rivet body: Aluminium alloy
Mandrel: Steel, zinc-plated



	Rivet body D ₁ x L mm	Grip range mm	Part no.	Quantity per box
2.4 Hole-Ø: 2.5 mm	2.4 x 4	0.5 - 2.0	145 4019	A 1,000
	2.4 x 6	2.0 - 4.0	143 3464	A 1,000
	2.4 x 8	4.0 - 6.0	145 4020	A 1,000
3 Hole-Ø: 3.1 mm	3 x 4	0.5 - 1.5	143 3466	A 500
	3 x 5	1.5 - 2.5	143 3467	A 500
	3 x 6	2.5 - 3.5	143 3468	A 500
	3 x 7	3.5 - 4.5	143 3469	A 500
	3 x 8	4.5 - 5.0	143 3470	A 500
	3 x 10	5.0 - 7.0	143 3471	A 500
	3 x 12	7.0 - 9.0	143 3472	A 500
	3 x 14	9.0 - 11.0	145 4022	A 500
	3 x 16	11.0 - 13.0	145 4023	A 500
	3 x 18	13.0 - 15.0	145 4024	A 250
	3 x 20	15.0 - 17.0	145 4025	A 250
	3 x 25	17.0 - 22.0	143 3473	A 250
	3 x 30	22.0 - 26.0	145 4026	A 250
3.2 Hole-Ø: 3.3 mm	3.2 x 4	0.5 - 1.5	143 3475	A 500
	3.2 x 6	1.5 - 3.5	143 3476	A 500
	3.2 x 8	3.5 - 5.0	143 3477	A 500
	3.2 x 10	5.0 - 7.0	143 3478	A 500
	3.2 x 12	7.0 - 9.0	143 3479	A 500
	3.2 x 14	9.0 - 11.0	143 3465	A 500
	3.2 x 16	11.0 - 13.0	143 3480	B 500
	3.2 x 18	13.0 - 15.0	143 3483	B 500
	3.2 x 20	15.0 - 17.0	143 3481	B 500
	3.2 x 25	17.0 - 22.0	143 3482	B 500
4 Hole-Ø: 4.1 mm	4 x 5	0.5 - 1.5	143 3484	A 500
	4 x 6	1.5 - 3.0	143 3485	A 500
	4 x 7	3.0 - 4.0	145 4028	A 500
	4 x 8	4.0 - 5.0	143 3486	A 500
	4 x 10	5.0 - 6.5	143 3487	A 500
	4 x 12	6.5 - 8.5	143 3488	B 500
	4 x 14	8.5 - 10.5	145 4029	B 500
	4 x 16	10.5 - 12.5	145 4030	B 500
	4 x 18	12.5 - 14.5	145 4031	B 500
	4 x 20	14.5 - 16.5	145 4032	B 500
	4 x 25	16.5 - 21.5	145 4033	B 500
	4 x 30	21.5 - 26.0	145 4034	B 250
	4 x 35	26.0 - 30.0	145 4035	B 250
	4 x 40	30.0 - 35.0	145 4036	B 250

	Rivet body D ₁ x L mm	Grip range mm	Part no.	Quantity per box
4.8 Hole-Ø: 4.9 mm	4.8 x 6	2.0 - 2.5	143 3493	B 500
	4.8 x 8	2.5 - 4.5	143 3494	B 500
	4.8 x 10	4.5 - 6.0	143 3495	B 500
	4.8 x 12	6.0 - 8.0	143 3496	B 500
	4.8 x 14	8.0 - 10.0	145 4043	B 500
	4.8 x 16	10.0 - 12.0	143 3497	B 500
	4.8 x 18	12.0 - 14.0	145 4044	B 500
	4.8 x 20	14.0 - 15.0	145 4045	B 250
	4.8 x 25	15.0 - 20.0	143 3498	B 250
	4.8 x 30	20.0 - 25.0	143 3499	A 100
5 Hole-Ø: 5.1 mm CE	5 x 6	2.0 - 2.5	143 3500	B 500
	5 x 8	2.5 - 4.5	143 3501	B 500
	5 x 10	4.5 - 6.0	143 3502	B 500
	5 x 12	6.0 - 8.0	143 3503	B 500
	5 x 14	8.0 - 10.0	145 4048	B 500
	5 x 16	10.0 - 12.0	143 3504	B 500
	5 x 18	12.0 - 14.0	145 4049	B 500
	5 x 20	14.0 - 15.0	145 4050	B 250
	5 x 25	15.0 - 20.0	143 3505	B 250
	5 x 30	20.0 - 25.0	145 4051	A 100
	5 x 35	25.0 - 30.0	145 4052	A 100
	5 x 40	30.0 - 35.0	145 4053	A 100
	5 x 45	35.0 - 40.0	145 4054	B 100
	5 x 50	40.0 - 45.0	145 4055	B 100
	5 x 55	45.0 - 48.0	145 4056	B 100
	5 x 60	48.0 - 52.0	145 4057	B 100
	5 x 65	52.0 - 57.0	145 4058	B 100
	5 x 70	57.0 - 62.0	145 4059	B 100
5 x 80	62.0 - 72.0	143 3506	B 100	
6 Hole-Ø: 6.1 mm	6 x 8	2.0 - 3.0	145 4060	B 250
	6 x 10	3.0 - 5.0	145 4061	B 250
	6 x 12	5.0 - 7.0	145 4062	B 250
	6 x 16	7.0 - 11.0	143 3507	B 250
	6 x 18	11.0 - 13.0	145 4064	B 250
	6 x 20	13.0 - 15.0	145 4065	B 250
	6 x 25	15.0 - 20.0	145 4066	B 200
	6 x 30	20.0 - 24.0	145 4067	B 200
	6 x 35	24.0 - 29.0	145 4068	B 100
	6 x 40	29.0 - 34.0	145 4069	B 100
6 x 50	34.0 - 44.0	143 3508	B 100	

Blind rivets alu/steel

	Rivet body D1 x L mm	Grip range mm	Part no.	Quantity per box
6.4 Hole-Ø: 6.5 mm	6.4 x 12	2.0 - 6.0	145 4070	B 250
	6.4 x 14	6.0 - 8.0	145 4071*	"
	6.4 x 16	6.0 - 10.0	145 4072	"
	6.4 x 18	10.0 - 12.0	145 4076*	"
	6.4 x 20	10.0 - 14.0	145 4073	B 200
	6.4 x 25	14.0 - 18.0	145 4074	"
	6.4 x 30	18.0 - 23.0	145 4075	B 100

Chart shear and tensile strength alu/steel standard

Rivet Ø mm	Shear strength N (kp)	Tensile strength N (kp)	Mandrel Ø mm	Max. head Ø mm
2.4	315 (32)	370 (38)	1.4	5.0
3	700 (71)	900 (92)	1.8	6.5
3.2	720 (73)	950 (97)	1.95	6.5
4 x 5-25	1,400 (143)	2,000 (204)	2.1	8.0
4 x 30-40 ■	850 (87)	1,000 (102)	2.1	8.0
4.8	1,800 (184)	2,700 (275)	2.7	9.5
5 x 6 - 35	2,000 (204)	2,800 (285)	2.7	9.5
5 x 40 - 80 ■	1,400 (143)	2,000 (204)	2.7	9.5
6	3,100 (316)	3,800 (388)	3.2	12.0
6.4	3,400 (347)	4,600 (469)	3.65	13.0

■ Rivet body: **AlMgSi** Test procedure according to DIN EN ISO 14589

Countersunk (120°)

Rivet body: Aluminium alloy
Mandrel: Steel, zinc-plated



	Rivet body D1 x L mm	Grip range mm	Part no.	Quantity per box
3 Hole-Ø: 3.1 mm	3 x 6	1.5 - 3.5	145 4078	"
	3 x 8	3.5 - 5.0	143 3509	"
	3 x 10	5.0 - 7.0	143 3510	"
	3 x 12	7.0 - 9.0	145 4079	"
	3 x 14	9.0 - 10.5	144 6367	"
	3 x 16	9.0 - 13.0	145 4080	"
4 Hole-Ø: 4.1 mm	4 x 6	1.5 - 3.0	145 4081	A 500
	4 x 8	3.0 - 5.0	143 3512	"
	4 x 10	5.0 - 6.5	145 4082	"
	4 x 12	6.5 - 8.5	143 3513	B 500
	4 x 14	8.5 - 10.5	144 6368*	"
	4 x 16	10.5 - 12.5	143 3514	"
	4 x 18	12.5 - 14.5	143 3511*	"
	4 x 20	14.5 - 16.5	145 4083	"

	Rivet body D1 x L mm	Grip range mm	Part no.	Quantity per box
5 Hole-Ø: 5.1 mm	5 x 8	2.0 - 4.5	143 3515	B 500
	5 x 10	4.5 - 6.0	143 3516	"
	5 x 12	6.0 - 8.0	145 4085	"
	5 x 16	8.0 - 12.0	145 4086	"
	5 x 18	12.0 - 14.0	145 4084	"
	5 x 20	14.0 - 15.0	145 4087	B 250
	5 x 25	15.0 - 20.0	143 3517	"
	5 x 30	20.0 - 25.0	145 4088	A 100
	5 x 35	25.0 - 30.0	145 4089	"

The information on shear and tensile strength, rivet pin diameters and the maximum setting head diameters can be found on page 34.

*Clearance – only while stocks last!

Blind rivets alu/steel

Large flange

Rivet body: Aluminium alloy
Mandrel: Steel, zinc-plated



	Rivet body D1 x L mm	Grip range mm	Part no.	Quantity per box
3.2 - K 9.5 Hole-Ø: 3.3 mm	3.2 x 6	1.5 - 3.5	145 4090*	A 500
	3.2 x 8	3.5 - 5.0	145 4091	"
	3.2 x 10	5.0 - 7.0	145 4092	"
	3.2 x 12	7.0 - 9.0	145 4093	"
	3.2 x 16	9.0 - 13.0	145 4094	B 500
4 - K 12 Hole-Ø: 4.1 mm	4 x 6	1.5 - 3.0	145 4095	B 500
	4 x 8	3.0 - 5.0	143 3518	"
	4 x 10	5.0 - 6.5	145 4096	"
	4 x 12	6.5 - 8.5	145 4097	"
	4 x 16	8.5 - 12.5	145 4098	"
4.8 - K 16 Hole-Ø: 4.9 mm	4.8 x 8	2.5 - 4.5	145 4106	B 250
	4.8 x 10	4.5 - 6.0	145 4107	"
	4.8 x 12	6.0 - 8.0	143 3519	"
	4.8 x 16	8.0 - 12.0	145 4109	"
	4.8 x 20	12.0 - 15.0	145 4111	"
4.8 x 25	15.0 - 20.0	143 3520	"	

	Rivet body D1 x L mm	Grip range mm	Part no.	Quantity per box
5 - K 11 Hole-Ø: 5.1 mm CE	5 x 8	2.5 - 4.5	143 3521	B 500
	5 x 10	4.5 - 6.0	145 4116	"
	5 x 12	6.0 - 8.0	143 3522	"
	5 x 14	8.0 - 10.0	145 4115	"
	5 x 16	10.0 - 12.0	145 4117	"
	5 x 18	12.0 - 14.0	145 4113	B 250
	5 x 20	14.0 - 15.0	145 4118	"
	5 x 25	15.0 - 20.0	145 4119	"
	5 x 30	20.0 - 25.0	145 4120	B 100
	5 - K 14 Hole-Ø: 5.1 mm CE	5 x 8	2.5 - 4.5	143 3523
5 x 10		4.5 - 6.0	145 4121	"
5 x 12		6.0 - 8.0	143 3524	"
5 x 14		8.0 - 10.0	145 4122	"
5 x 16		10.0 - 12.0	145 4123	"
5 x 18		12.0 - 14.0	145 4124	"
5 x 20		14.0 - 15.0	145 4125	"
5 x 25		15.0 - 20.0	145 4126	"
5 x 30		20.0 - 25.0	145 4127	B 100

*Clearance – only while stocks last!

Chart shear and tensile strength Alu/Steel counter sunk and large flange

Rivet Ø mm	Shear strength		Tensile strength		Mandrel Ø mm	Max. head Ø Alu / Steel mm
	N	(kp)	N	(kp)		
3	700	(71)	900	(91)	1.8	6.0
4	1,400	(143)	2,000	(204)	2.1	7.5
5	2,000	(204)	2,800	(285)	2.7	9.0
3.2 K 9,5 only Al/Steel	720	(73)	950	(97)	1.95	9.5
4 K 12 only Al/Steel	1,400	(143)	2,000	(204)	2.1	12.0
4.8 K 16 only Al/Steel	1,800	(184)	2,700	(275)	2.7	16.0
5 K 11	2,000	(204)	2,800	(285)	2.7	11.0
5 K 14	2,000	(204)	2,800	(285)	2.7	14.0

Test procedure according to DIN EN ISO 14589

Blind rivets alu/stainless

Standard (Dome head)

Rivet body: Aluminium alloy
Mandrel: Stainless steel A2



	Rivet body D1 x L mm	Grip range mm	Part no.	Quantity per box
3 Hole-Ø: 3.1 mm	3 x 4	0.5 - 1.5	145 5036	A 500
	3 x 6	1.5 - 3.5	143 3581	"
	3 x 8	3.5 - 5.0	143 3582	"
	3 x 10	5.0 - 7.0	145 5037	"
	3 x 12	7.0 - 9.0	145 5038	"
	3 x 16	9.0 - 13.0	145 5039	"
3.2 Hole-Ø: 3.3 mm	3.2 x 4	0.5 - 1.5	145 5048*	A 500
	3.2 x 6	1.5 - 3.5	145 5049	"
	3.2 x 8	3.5 - 5.0	145 5044	"
	3.2 x 10	5.0 - 7.0	145 5045	"
	3.2 x 12	7.0 - 9.0	145 5046	"
	3.2 x 14	9.0 - 11.0	144 6433	"
	3.2 x 16	11.0 - 13.0	145 5050	B 500
	3.2 x 18	13.0 - 15.0	145 5051*	"
	3.2 x 20	15.0 - 17.0	144 6434*	"
	3.2 x 25	17.0 - 22.0	145 5052*	"
4 Hole-Ø: 4.1 mm CE	4 x 6	1.5 - 3.0	143 3589	A 500
	4 x 8	3.0 - 5.0	143 3590	"
	4 x 10	5.0 - 6.5	143 3591	"
	4 x 12	6.5 - 8.5	143 3592	B 500
	4 x 14	8.5 - 10.5	143 3588	"
	4 x 16	10.5 - 12.5	143 3594	"
	4 x 18	12.5 - 14.5	143 3593	"
	4 x 20	14.5 - 16.5	143 3595	"
	4 x 25	16.5 - 21.5	143 3596	"

Material surcharge will be added at a daily rate.

The information on shear and tensile strength, rivet pin diameters and the maximum setting head diameters can be found on page 36.

	Rivet body D1 x L mm	Grip range mm	Part no.	Quantity per box
4.8 Hole-Ø: 4.9 mm CE	4.8 x 6	2.0 - 2.5	143 3583*	B 500
	4.8 x 8	2.5 - 4.5	145 5040	"
	4.8 x 10	4.5 - 6.0	145 5041	"
	4.8 x 12	6.0 - 8.0	145 5042	"
	4.8 x 14	8.0 - 10.0	145 5043	"
	4.8 x 16	10.0 - 12.0	143 3584	"
	4.8 x 18	12.0 - 14.0	143 3585*	"
	4.8 x 20	14.0 - 15.0	143 3586*	B 250
	5 Hole-Ø: 5.1 mm CE	5 x 8	2.5 - 4.5	143 3597
5 x 10		4.5 - 6.0	143 3598	"
5 x 12		6.0 - 8.0	143 3599	"
5 x 14		8.0 - 10.0	143 3600	"
5 x 16		10.0 - 12.0	145 5053	"
5 x 18		12.0 - 14.0	145 5054	"
5 x 20		14.0 - 15.0	143 3601	B 250
5 x 25		15.0 - 20.0	145 5055	"
5 x 30		20.0 - 25.0	145 5056	A 100
5 x 35		25.0 - 30.0	145 5057	"
5 x 40		30.0 - 35.0	143 3602	"

*Clearance – only while stocks last!

Blind rivets alu/stainless

Large flange

Rivet body: Aluminium alloy
Mandrel: Stainless steel A2

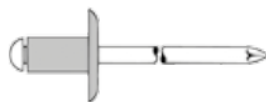

	Rivet body D1 x L mm	Grip range mm	Part no.	Quantity per box
5 - K 11 Hole-Ø: 5.1 mm CE	5 x 8	2.5 - 4.5	143 3605	B 500
	5 x 10	4.5 - 6.0	143 3606	"
	5 x 12	6.0 - 8.0	143 3607	"
	5 x 14	8.0 - 10.0	143 3603	"
	5 x 16	10.0 - 12.0	143 3608	"
	5 x 18	12.0 - 14.0	143 3604*	B 250
	5 x 20	14.0 - 15.0	143 3609*	"
	5 x 25	15.0 - 20.0	143 3610*	"
	5 x 30	20.0 - 25.0	143 3611*	B 100

	Rivet body D1 x L mm	Grip range mm	Part no.	Quantity per box
5 - K 14 Hole-Ø: 5.1 mm CE	5 x 8	2.5 - 4.5	143 3612	B 250
	5 x 10	4.5 - 6.0	143 3613	"
	5 x 12	6.0 - 8.0	143 3614	"
	5 x 14	8.0 - 10.0	143 3619	"
	5 x 16	10.0 - 12.0	143 3615	"
	5 x 18	12.0 - 14.0	143 3620	"
	5 x 20	14.0 - 15.0	143 3616	"
	5 x 25	15.0 - 20.0	143 3617	"
	5 x 30	20.0 - 25.0	143 3618	B 100

*Clearance – only while stocks last!

Material surcharge will be added at a daily rate.

Chart shear and tensile strength alu/stainless standard and large flange

Rivet Ø mm	Shear strength		Tensile strength		Mandrel Ø mm	Max. head Ø Alu / Stainless mm
	N	(kp)	N	(kp)		
3	700	(71)	900	(91)	1.8	6.5
3.2	720	(73)	950	(97)	1.95	6.5
4	1,400	(143)	2,000	(204)	2.1	8.0
4.8	1,800	(184)	2,700	(275)	2.7	9.5
5	2,000	(204)	2,800	(285)	2.7	9.5
5 K 11	2,000	(204)	2,800	(285)	2.7	11.0
5 K 14	2,000	(204)	2,800	(285)	2.7	14.0

Test procedure according to DIN EN ISO 14589

Blind rivets alu/alu

Standard (Dome head)

Rivet body: Aluminium alloy
Mandrel: Aluminium alloy



	Rivet body D1 x L mm	Grip range mm	Part no.	Quantity per box
3.2 Hole-Ø: 3.3 mm	3.2 x 6.1	0.8 - 3.2	143 3751	A 500
	3.2 x 7.6	3.2 - 4.8	143 3752	"
	3.2 x 9.2	4.8 - 6.4	145 5510	"
	3.2 x 12.3	6.4 - 9.5	145 5511*	"
	3.2 x 15.5	9.5 - 12.7	145 5512*	B 500
4 Hole-Ø: 4.1 mm	4 x 6.6	1.5 - 3.2	145 5513	B 500
	4 x 9.8	3.2 - 6.4	143 3753	"
	4 x 12.9	6.4 - 9.5	143 3754*	"
	4 x 16.1	9.5 - 12.7	145 5514*	"

	Rivet body D1 x L mm	Grip range mm	Part no.	Quantity per box
4.8 Hole-Ø: 4.9 mm	4.8 x 7.2	1.5 - 3.2	143 3755*	B 500
	4.8 x 10.3	3.2 - 6.4	143 3756	"
	4.8 x 13.5	6.4 - 9.5	145 5515	"
	4.8 x 16.7	9.5 - 12.7	145 5516*	"
	4.8 x 19.9	12.7 - 15.9	145 5517*	"
	4.8 x 23.0	15.9 - 19.0	145 5518*	B 250
6.4 Hole-Ø: 6.5 mm	6.4 x 12.0	1.5 - 6.4	143 3757	B 250
	6.4 x 14.9	6.4 - 9.5	143 3758	"
	6.4 x 18.1	9.5 - 12.7	143 3759	A 100
	6.4 x 24.4	12.7 - 19.0	143 3760	"

Large flange

Rivet body: Aluminium alloy
Mandrel: Aluminium alloy

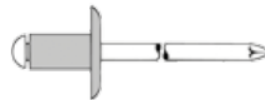

	Rivet body D1 x L mm	Grip range mm	Part no.	Quantity per box
3.2 - K 9.5 Hole-Ø: 3.3 mm	3.2 x 6.1	0.8 - 3.2	145 5519*	A 500
	3.2 x 9.2	3.2 - 6.4	145 5520*	"
	3.2 x 12.3	6.4 - 9.5	145 5521*	B 500

	Rivet body D1 x L mm	Grip range mm	Part no.	Quantity per box
4.8 - K 16 Hole-Ø: 4.9 mm	4.8 x 10.3	1.5 - 6.4	145 5522	B 250
	4.8 x 13.5	6.4 - 9.5	145 5523	"
	4.8 x 16.7	9.5 - 12.7	145 5524*	"
	4.8 x 19.9	12.7 - 15.9	145 5525*	"
	4.8 x 23.0	15.9 - 19.0	145 5526*	"

Chart shear and tensile strength alu/alu standard and large flange

Rivet Ø mm	Shear strength		Tensile strength		Mandrel Ø mm	Max. head Ø mm
	N	(kp)	N	(kp)		
3.2	530	(54)	660	(67)	1.95	6.5
4	840	(85)	1,020	(103)	2.45	8.0
4.8	1,150	(117)	1,420	(144)	2.9	9.5
6.4	2,040	(207)	2,490	(253)	3.85	12.9
3.2 K 9.5	725	(74)	930	(95)	1.95	9.5
4.8 K 16	1,520	(155)	1,960	(200)	2.9	16.0

Test procedure according to DIN EN ISO 14589

*Clearance – only while stocks last!

Blind rivets steel/steel

Standard (Dome head)

Rivet body: Steel, zinc-plated
Mandrel: Steel, zinc-plated



	Rivet body D1 x L mm	Grip range mm	Part no.	Quantity per box
3 Hole-Ø: 3.1 mm	3 x 5	0.5 - 2.0	145 4595	A 500
	3 x 6	2.0 - 3.0	143 3551	"
	3 x 8	3.0 - 5.0	143 3552	"
	3 x 10	5.0 - 6.5	145 4596	"
	3 x 12	6.5 - 8.5	145 4597	"
	3 x 14	9.0 - 11.0	144 6415*	"
	3 x 16	8.5 - 12.5	145 4598	B 500
	3 x 18	12.5 - 14.5	145 4599*	"
3 x 20	14.5 - 16.5	145 4600*	"	
3.2 Hole-Ø: 3.3 mm	3.2 x 6	0.5 - 3.0	145 4602	A 500
	3.2 x 8	3.0 - 5.0	143 3553	"
	3.2 x 10	5.0 - 6.5	143 3554	"
	3.2 x 12	6.5 - 8.5	145 4603	"
	3.2 x 14	9.0 - 11.0	144 6416*	"
	3.2 x 16	8.5 - 12.5	145 4604	B 500
	3.2 x 18	12.5 - 14.5	145 4601	"
3.2 x 20	14.5 - 16.5	145 4605	"	
4 Hole-Ø: 4.1 mm	4 x 6	0.5 - 2.5	145 4606	A 500
	4 x 8	2.5 - 4.5	143 3555	"
	4 x 10	4.5 - 6.5	143 3556	B 500
	4 x 12	6.5 - 8.5	143 3557	"
	4 x 14	8.5 - 10.5	144 6417*	"
	4 x 16	8.5 - 12.0	145 4607	"
	4 x 18	12.0 - 14.0	145 4609	"
	4 x 20	14.0 - 16.0	145 4608	"
	4 x 25	16.0 - 21.0	145 4610	"
4.8 Hole-Ø: 4.9 mm	4.8 x 8	2.0 - 4.0	143 3558	B 500
	4.8 x 10	4.0 - 6.0	143 3559	"
	4.8 x 12	6.0 - 8.0	143 3560	"
	4.8 x 14	8.0 - 10.0	145 4611*	"
	4.8 x 16	8.0 - 11.0	143 3561	"
	4.8 x 20	11.0 - 15.0	143 3562	B 250
4.8 x 25	15.0 - 20.0	145 4612	"	

	Rivet body D1 x L mm	Grip range mm	Part no.	Quantity per box
5 Hole-Ø: 5.1 mm	5 x 8	2.0 - 4.0	145 4613	B 500
	5 x 10	4.0 - 6.0	145 4614	"
	5 x 12	6.0 - 8.0	145 4615	"
	5 x 16	9.5 - 11.0	145 4617	"
	5 x 20	11.0 - 15.0	145 4619	B 250
	5 x 25	15.0 - 20.0	145 4620	"
	5 x 30	20.0 - 25.0	145 4621	A 100
	5 x 35	25.0 - 30.0	145 4622	"
	5 x 40	30.0 - 34.0	145 4623	B 100
	5 x 45	34.0 - 39.0	145 4624	B 100
	5 x 50	39.0 - 44.0	145 4625	B 100
6 Hole-Ø: 6.1 mm	6 x 10	2.5 - 4.5	145 4626	B 250
	6 x 12	4.5 - 6.5	145 4627	"
	6 x 14	6.5 - 8.5	145 4628	"
	6 x 16	8.5 - 10.5	145 4629	"
	6 x 20	10.5 - 14.5	145 4630	"
	6 x 25	14.5 - 19.5	145 4631	"
6.4 Hole-Ø: 6.5 mm	6.4 x 8	1.0 - 3.0	143 3563	B 250
	6.4 x 12	3.0 - 6.0	143 3564	"
	6.4 x 16	6.0 - 9.0	143 3565	"
	6.4 x 18	9.0 - 11.0	145 4632*	B 200
	6.4 x 20	9.0 - 13.0	143 3566	"
6.4 x 25	13.0 - 17.0	143 3567	"	

*Clearance – only while stocks last!

Blind rivets steel/steel

Countersunk (120°)

Rivet body: Steel, zinc-plated
Mandrel: Steel, zinc-plated

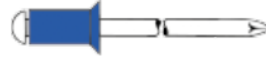

	Rivet body D ₁ x L mm	Grip range mm	Part no.	Quantity per box
3 Hole-Ø: 3.1 mm	3 x 6	1.0 - 3.0	145 4633	A 500
	3 x 8	3.0 - 5.0	145 4634	"
	3 x 10	5.0 - 6.5	145 4635	"
	3 x 12	6.5 - 8.5	145 4636	"
4 Hole-Ø: 4.1 mm	4 x 6	1.5 - 2.5	145 4637	A 500
	4 x 8	2.5 - 4.5	145 4638	"
	4 x 10	4.5 - 6.5	145 4639	B 500
	4 x 12	6.5 - 8.5	145 4640	"
	4 x 16	8.5 - 12.0	145 4641	"
	4 x 20	12.0 - 16.0	145 4642*	"

	Rivet body D ₁ x L mm	Grip range mm	Part no.	Quantity per box
5 Hole-Ø: 5,1 mm	5 x 8	2.0 - 4.0	145 4644	B 500
	5 x 10	4.0 - 6.0	145 4645	"
	5 x 12	6.0 - 8.0	145 4646	"
	5 x 14	8.0 - 9.5	145 4643*	"
	5 x 16	9.5 - 11.0	145 4647	"
	5 x 20	11.0 - 15.0	145 4648	B 250
	5 x 25	15.0 - 20.0	145 4649	"

*Clearance – only while stocks last!

Chart shear and tensile strength steel/steel standard

Rivet Ø mm	Shear strength		Tensile strength		Mandrel Ø mm	Max. head Ø mm
	N	(kp)	N	(kp)		
3	1,000	(102)	1,300	(133)	1.95	6.5
3.2	1,200	(122)	1,500	(153)	2.0	6.5
4	2,000	(204)	2,500	(255)	2.5	8.0
4.8	2,900	(296)	4,000	(408)	3.0	9.5
5	3,100	(316)	4,400	(449)	3.0	9.5
6	4,400	(449)	6,000	(612)	3.65	12.0
6.4	4,900	(500)	6,800	(694)	3.85	13.0

Test procedure according to DIN EN ISO 14589

Chart shear and tensile strength steel/steel Counter sunk

Rivet Ø mm	Shear strength		Tensile strength		Mandrel Ø mm	Max. head Ø mm
	N	(kp)	N	(kp)		
3	1,000	(102)	1,300	(133)	1.95	6.0
4	2,000	(204)	2,500	(255)	2.5	7.5
5	3,100	(316)	4,400	(449)	3.0	9.0

Test procedure according to DIN EN ISO 14589

Blind rivets copper/steel

Standard (Dome head)

Rivet body: Copper
Mandrel: Steel, zinc-plated



	Rivet body D1 x L mm	Grip range mm	Part no.	Quantity per box
3 Hole-Ø: 3.1 mm	3 x 4	0.5 - 1.5	145 5279	A 500
	3 x 6	1.5 - 3.0	143 3655	"
	3 x 8	3.0 - 5.0	143 3656	"
	3 x 10	5.0 - 7.0	143 3657	"
	3 x 12	7.0 - 9.0	145 5280*	"

	Rivet body D1 x L mm	Grip range mm	Part no.	Quantity per box
4 Hole-Ø: 4.1 mm	4 x 6	0.5 - 3.5	143 3658	A 500
	4 x 8	3.5 - 4.5	145 5281	"
	4 x 10	4.5 - 6.5	145 5282	"
	4 x 12	6.5 - 8.5	145 5283*	"

Blind rivets copper/bronze

Standard (Dome head)

Rivet body: Copper
Mandrel: Bronze



	Rivet body D1 x L mm	Grip range mm	Part no.	Quantity per box
3 Hole-Ø: 3.1 mm	3 x 4	0.5 - 1.5	145 5289	A 500
	3 x 6	1.5 - 3.0	145 5290	"
	3 x 8	3.0 - 5.0	143 3661	"
	3 x 10	5.0 - 7.0	145 5291	"
	3 x 12	7.0 - 9.0	145 5292*	"

	Rivet body D1 x L mm	Grip range mm	Part no.	Quantity per box
4 Hole-Ø: 4.1 mm	4 x 6	0.5 - 3.5	145 5293	A 500
	4 x 8	3.5 - 4.5	145 5294	"
	4 x 10	4.5 - 6.5	145 5295	"

Chart shear and tensile strength copper/steel and copper/bronze

Rivet Ø mm	Shear strength N (kp)	Tensile strength N (kp)	Mandrel Ø mm	Max. head Ø mm
3	800 (82)	1,000 (102)	1.8	6.5
4	1,500 (163)	2,200 (225)	2.1	8.0

Test procedure according to DIN EN ISO 14589

*Clearance – only while stocks last!

Blind rivets A2 Stainless steel



Standard (Dome head)

Rivet body: Stainless steel A2 – Nr. 1.4567
Mandrel: Stainless steel A2



	Rivet body D1 x L mm	Grip range mm	Part no.	Quantity per box
3 Hole-Ø: 3.1 mm	3 x 6	1.0 - 3.0	143 3621	A 500
	3 x 8	3.0 - 5.0	143 3622	"
	3 x 10	5.0 - 6.5	145 5157	"
	3 x 12	6.5 - 8.5	145 5158	"
	3 x 14	8.5 - 10.5	145 5159	"
	3 x 16	10.5 - 12.5	145 5160	"
3.2 Hole-Ø: 3.3 mm	3.2 x 6	1.0 - 3.0	143 3623	A 500
	3.2 x 8	3.0 - 5.0	143 3624	"
	3.2 x 10	5.0 - 6.5	143 3625	"
	3.2 x 12	6.5 - 8.5	143 3626	"
	3.2 x 16	8.5 - 12.5	145 5161	"
4 Hole-Ø: 4.1 mm CE	4 x 6	1.0 - 2.5	143 3627	A 500
	4 x 8	2.5 - 4.5	143 3628	"
	4 x 10	4.5 - 6.5	143 3629	B 500
	4 x 12	6.5 - 8.5	143 3630	"
	4 x 14	8.5 - 10.5	143 3633	"
	4 x 16	10.5 - 12.0	143 3631	"
	4 x 20	12.0 - 16.0	143 3632	"
	4 x 25	16.0 - 21.0	145 5163	"

	Rivet body D1 x L mm	Grip range mm	Part no.	Quantity per box
4.8 Hole-Ø: 4.9 mm CE	4.8 x 6	1.5 - 3.0	145 5164	B 500
	4.8 x 8	2.0 - 4.0	143 3634	"
	4.8 x 10	4.0 - 6.0	143 3635	"
	4.8 x 12	6.0 - 8.0	143 3636	"
	4.8 x 14	8.0 - 9.5	145 5165	"
	4.8 x 16	9.5 - 11.0	143 3637	"
	4.8 x 20	11.0 - 15.0	143 3638	B 250
	4.8 x 25	15.0 - 20.0	145 5166	B 250
	4.8 x 30	20.0 - 25.0	143 3639	A 100
	4.8 x 35	25.0 - 30.0	145 5167*	"
5 Hole-Ø: 5.1 mm	5 x 8	2.0 - 4.0	145 5168	B 500
	5 x 10	4.0 - 6.0	145 5169	"
	5 x 12	6.0 - 8.0	145 5170	"
	5 x 14	8.0 - 9.5	145 5171	"
	5 x 16	9.5 - 11.0	145 5172	"
	5 x 20	11.0 - 15.0	143 3646	B 250
	5 x 25	15.0 - 20.0	143 3647	"
	5 x 30	20.0 - 25.0	143 3648	A 100
	5 x 35	25.0 - 30.0	145 5173	"
	5 x 40	30.0 - 34.0	143 3649	"

Material surcharge will be added at a daily rate.

Countersunk (120°)

Rivet body: Stainless steel A2 – Nr. 1.4567
Mandrel: Stainless steel A2



	Rivet body D1 x L mm	Grip range mm	Part no.	Quantity per box
3 Hole-Ø: 3.1 mm	3 x 6	1.5 - 3.0	145 5174	A 500
	3 x 8	3.0 - 5.0	143 3650	"
	3 x 10	5.0 - 6.5	145 5175	"
	3 x 12	6.5 - 8.5	145 5176*	"
3.2 Hole-Ø: 3.3 mm	3.2 x 6	1.5 - 3.0	145 5177	A 500
	3.2 x 8	3.0 - 5.0	145 5178	"
	3.2 x 10	5.0 - 6.5	145 5179	"
	3.2 x 12	6.5 - 8.5	145 5180*	"

	Rivet body D1 x L mm	Grip range mm	Part no.	Quantity per box
4 Hole-Ø: 4.1 mm	4 x 8	1.5 - 4.5	145 5181	A 500
	4 x 10	4.5 - 6.5	143 3651	B 500
	4 x 12	6.5 - 8.5	143 3652	"
4.8 Hole-Ø: 4.9 mm	4.8 x 8	2.5 - 4.0	145 5182*	B 500
	4.8 x 10	4.0 - 6.0	145 5183	"
	4.8 x 12	6.0 - 8.0	145 5184	"
5 Hole-Ø: 5.1 mm	5 x 8	2.0 - 4.0	145 5185	B 500
	5 x 10	4.0 - 6.0	145 5186	"
	5 x 12	6.5 - 8.5	143 3653	"

Material surcharge will be added at a daily rate.

*Clearance – only while stocks last!

The information on shear and tensile strength, rivet pin diameters and the maximum setting head diameters can be found on page 42.

Blind rivets A2 Stainless steel



Large flange

Rivet body: Stainless steel A2 – Nr. 1.4567
Mandrel: Stainless steel A2



Material surcharge will be added at a daily rate.

	Rivet body D1 x L mm	Grip range mm	Part no.	Quantity per box
4.8 - K 15 Hole-Ø: 4.9 mm CE	4.8 x 14	8.0 - 9.5	143 3640	B 250
	4.8 x 16	9.5 - 11.0	143 3641	"
	4.8 x 20	11.0 - 15.0	143 3642	"
	4.8 x 25	15.0 - 20.0	143 3643	B 200
	4.8 x 30	20.0 - 25.0	143 3644	B 100

Chart shear and tensile strength A2-stainless steel standard, countersunk and large flange

A2-stainless steel / A2-stainless steel counter sunk						
Rivet Ø mm	Shear strength		Tensile strength		Mandrel Ø mm	Max. head Ø mm
	N	(kp)	N	(kp)		
3	1,600	(163)	2,000	(205)	2.0	6.5
3.2	1,900	(275)	2,500	(255)	2.0	6.5
4	2,700	(275)	3,600	(367)	2.6	8.0
4 x 20 - 25 ■	3,800	(385)	4,500	(479)	2.6	8.0
4.8	4,000	(408)	5,000	(510)	3.2	9.5
5	4,700	(479)	5,900	(602)	3.2	9.5
5 x 40 ■	5,900	(602)	7,200	(735)	3.2	9.5

A2-Stainless steel Large flange						
Rivet Ø mm	Shear strength		Tensile strength		Mandrel Ø mm	Max. head Ø mm
	N	(kp)	N	(kp)		
4.8	4,000	(408)	5,000	(510)	3.2	15.0

Test procedure according to DIN EN ISO 14589

■ Hollow rivet stainless steel A2 tube, material no. 1.4301

Blind rivets A4 Stainless steel



Standard (Dome head)

Rivet body: Stainless steel A4 – Nr. 1.4578
Mandrel: Stainless steel A4



	Rivet body D ₁ x L mm	Grip range mm	Part no.	Quantity per box
3 Hole-Ø: 3.1 mm	3 x 6	1.0 - 3.0	145 5530	A 500
	3 x 8	3.0 - 5.0	145 5531	"
	3 x 10	5.0 - 6.5	145 5532	"
	3 x 12	6.5 - 8.5	145 5533	"
3.2 Hole-Ø: 3.3 mm	3.2 x 6	1.0 - 3.0	143 3761	A 500
	3.2 x 8	3.0 - 5.0	143 3762	"
	3.2 x 10	5.0 - 6.5	143 3763	"
	3.2 x 12	6.5 - 8.5	145 5535*	"
4 Hole-Ø: 4.1 mm CE	4 x 6	1.0 - 2.5	145 5534	A 500
	4 x 8	2.5 - 4.5	143 3764	"
	4 x 10	4.5 - 6.5	143 3765	B 500
	4 x 12	6.5 - 8.5	143 3766	"
	4 x 14	8.5 - 10.5	145 5536	"
	4 x 16	10.5 - 12.0	143 3767	"

*Clearance – only while stocks last!

Material surcharge will be added at a daily rate.

	Rivet body D ₁ x L mm	Grip range mm	Part no.	Quantity per box
4.8 Hole-Ø: 4.9 mm CE	4.8 x 6	1.5 - 3.0	143 3768*	B 500
	4.8 x 8	3.0 - 4.5	143 3769	"
	4.8 x 10	4.5 - 6.0	143 3770	"
	4.8 x 12	6.0 - 7.5	143 3777	"
	4.8 x 14	8.0 - 9.5	143 3771*	"
	4.8 x 16	9.5 - 11.0	143 3772	"
	4.8 x 20	11.0 - 15.0	143 3773	B 250
	4.8 x 25	15.0 - 20.0	143 3774	"
	4.8 x 30	20.0 - 25.0	143 3775	A 100
	4.8 x 35	25.0 - 30.0	143 3776	"
5 Hole-Ø: 5.1 mm	5 x 8	2.0 - 4.0	145 5537	B 500
	5 x 10	4.0 - 6.0	143 3778	"
	5 x 12	6.0 - 8.0	143 3779	"
	5 x 16	8.0 - 11.0	143 3781	"
	5 x 20	11.0 - 15.0	145 5538	B 250
	5 x 25	15.0 - 20.0	143 3782	"
	5 x 30	20.0 - 25.0	143 3783	A 100
	5 x 35	25.0 - 30.0	143 3784	"

Large flange

Rivet body: Stainless steel A4 – Nr. 1.4578
Mandrel: Stainless steel A4



	Rivet body D ₁ x L mm	Grip range mm	Part no.	Quantity per box
4.8 - K 15 Hole-Ø: 4.9 mm CE	4.8 x 14	8.0 - 9.5	143 3785	B 250
	4.8 x 16	9.5 - 11.0	143 3786	"
	4.8 x 20	11.0 - 15.0	143 3787	"
	4.8 x 25	15.0 - 20.0	143 3788	B 200
	4.8 x 30	20.0 - 25.0	143 3789	B 100
	4.8 x 35	25.0 - 30.0	143 3790	"

Material surcharge will be added at a daily rate.

The information on shear and tensile strength, rivet pin diameters and the maximum setting head diameters can be found on page 44.

Blind rivets A4 Stainless steel



Chart shear and tensile strength A4-stainless steel standard and large flange

Rivet Ø mm	Type	Shear strength		Tensile strength		Mandrel Ø mm	Max. head Ø mm
		N	(kp)	N	(kp)		
3	Standard	1,600	(163)	2,000	(205)	2.0	6.5
3.2	Standard	1,900	(275)	2,500	(255)	2.0	6.5
4	Standard	2,700	(275)	3,600	(367)	2.6	8.0
4.8	Large flange	4,000	(408)	5,000	(510)	3.2	15.0
4.8	Standard	4,000	(408)	5,000	(510)	3.2	9.5
5	Standard	4,700	(479)	5,900	(602)	3.2	9.5

Test procedure according to DIN EN ISO 14589

Blind rivets Monel®



Standard (Dome head)

Rivet body: Nickel-copper-alloy - Nr. 2.4360
Mandrel: Stainless steel-A2



	Rivet body D ₁ x L mm	Grip range mm	Part no.	Quantity per box
4 Hole-Ø: 4.1 mm	4 x 6	1.5 - 2.5	145 3939*	A 500
	4 x 8	2.5 - 4.5	145 3940*	A 500
	4 x 10	4.5 - 6.5	145 3941*	B 500
	4 x 12	6.5 - 8.5	145 3942*	B 500
	4 x 14	8.5 - 10.5	145 3943*	B 500
	4 x 16	10.5 - 12.0	145 3944*	B 500

	Rivet body D ₁ x L mm	Grip range mm	Part no.	Quantity per box
4.8 Hole-Ø: 4.9 mm	4.8 x 6	1.5 - 3.0	145 3948*	B 500
	4.8 x 8	2.0 - 4.0	145 3949*	B 500
	4.8 x 12	6.0 - 8.0	145 3951*	B 500
	4.8 x 14	8.0 - 9.0	145 3952*	B 500
	4.8 x 20	11.0 - 15.0	145 3954*	B 250
	4.8 x 25	15.0 - 20.0	145 3955*	B 250
	4.8 x 30	20.0 - 25.0	145 3956*	A 100
	4.8 x 35	25.0 - 30.0	145 3957*	A 100

Countersunk (120°)

Rivet body: Nickel-copper-alloy - Nr. 2.4360
Mandrel: Stainless steel-A2

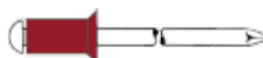

	Rivet body D ₁ x L mm	Grip range mm	Part no.	Quantity per box
4 Hole-Ø: 4.1 mm	4 x 8	1.5 - 4.5	145 3945*	A 500
	4 x 10	4.5 - 6.5	145 3946*	B 500
	4 x 12	6.5 - 8.5	145 3947*	B 500

	Rivet body D ₁ x L mm	Grip range mm	Part no.	Quantity per box
4.8 Hole-Ø: 4.9 mm	4.8 x 8	2.5 - 4.0	145 3958*	B 500
	4.8 x 10	4.0 - 6.0	145 3959*	B 500
	4.8 x 12	6.0 - 8.0	145 3960*	B 500

*Clearance – only while stocks last!

Blind rivets Monel®



Large flange

Rivet body: Nickel-Copper-Legierung - Nr. 2.4360
Mandrel: Stainless steel-A2



	Rivet body D1 x L mm	Grip range mm	Part no.	Quantity per box
4.8 Hole-Ø: 4.9 mm	4.8 x 14	8.0 - 9.5	145 3961	B 250
	4.8 x 16	9.5 - 11.0	145 3962	"
	4.8 x 20	11.0 - 15.0	145 3963	"

	Rivet body D1 x L mm	Grip range mm	Part no.	Quantity per box
4.8 Hole-Ø: 4.9 mm	4.8 x 25	15.0 - 20.0	145 3964	B 200
	4.8 x 30	20.0 - 25.0	145 3965	B 100
	4.8 x 35	25.0 - 30.0	145 3966	B 100

Chart shear and tensile strength monel® standard, countersunk and large flange

Rivet Ø mm	Shear strength		Tensile strength		Mandrel Ø mm	Max. head Ø mm
	N	(kp)	N	(kp)		
4	2,100	(214)	3,100	(316)	2.6	8.0 (Standard, countersunk)
4.8	3,500	(408)	4,500	(510)	3.2	9.5 (Standard, countersunk)
4.8	3,500	(408)	4,500	(510)	3.2	15 (Large flange)

Test procedure according to DIN EN ISO 14589

Blind rivets Stinox

Standard (Dome head)

Rivet body: Stainless steel A2 – Nr. 1.4567
Mandrel: Steel, zinc-plated



	Rivet body D1 x L mm	Grip range mm	Part no.	Quantity per box
3 Hole-Ø: 3.1 mm	3 x 6	1.0 - 3.0	145 5297	A 500
	3 x 8	3.0 - 5.0	145 5298	"
	3 x 10	5.0 - 6.5	145 5299	"
3.2 Hole-Ø: 3.3 mm	3.2 x 6	1.0 - 3.0	145 5300	A 500
	3.2 x 8	3.0 - 5.0	145 5301	"
	3.2 x 10	5.0 - 6.5	145 5302	"

	Rivet body D1 x L mm	Grip range mm	Part no.	Quantity per box
4 Hole-Ø: 4.1 mm	4 x 6	1.0 - 2.5	145 5303	A 500
	4 x 8	2.5 - 4.5	145 5304	"
	4 x 10	4.5 - 6.5	145 5305	B 500
	4 x 12	6.5 - 8.5	145 5306	"
	4 x 14	8.5 - 10.5	144 6455	"
	4 x 16	8.5 - 12.0	145 5307	"
4.8 Hole-Ø: 4.9 mm	4.8 x 8	2.0 - 4.0	145 5308	B 500
	4.8 x 10	4.0 - 6.0	145 5309	"
	4.8 x 12	6.0 - 8.0	145 5310	"
5 Hole-Ø: 5.1 mm	5 x 8	2.0 - 4.0	145 5311	B 500
	5 x 10	4.0 - 6.0	145 5312	"
	5 x 12	6.0 - 8.0	145 5313	"

Material surcharge will be added at a daily rate.

Chart shear and tensile strength stinox standard

Rivet Ø mm	Shear strength		Tensile strength		Mandrel Ø mm	Max. head Ø mm
	N	(kp)	N	(kp)		
3	1,600	(163)	2,000	(205)	2.0	6.5
3.2	1,900	(275)	2,500	(255)	2.0	6.5
4	2,700	(275)	3,600	(367)	2.6	8.0
4.8	4,000	(408)	5,000	(510)	3.2	9.5
5	4,700	(479)	5,900	(602)	3.2	9.5

Test procedure according to DIN EN ISO 14589

PolyGrip® – A most versatile small fellow

GESIPA®-PolyGrip® – Favorite for difficult and demanding applications for all kinds of materials in industrial environment.



The GESIPA® PolyGrip® range of blind rivets, originally meant to be only a multigrip rivet has meanwhile shown other multiple talents. This makes it a favourite choice for difficult and demanding applications in industrial environment. Whether in aluminium, steel or stainless steel, outdoor or indoor, with hard or soft application materials, critical hole diameters and tolerances, when nothing seems to work properly, GESIPA® PolyGrip® will usually save the day.

Main features

• Large grip range:

One single PolyGrip® blind rivet can replace up to five different sizes of standard DIN blind rivets.

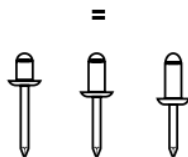

PolyGrip®

Your benefits:

- Type simplification
- Limited type variety for reduced stocks
- Lower risk of confusion therefore fewer mistakes in production

- **Outstanding hole filling capability:** The rivet body expands radially during the setting process and compensates hole tolerances, centering deviations and differences in diameter, thus always building up a playfree and tight joint.
- **Safe rest mandrel locking:** PolyGrip® blind rivets neither generate rattling noises due to free moving rest mandrels nor do they allow the risk of loss of the rest mandrel.
- **Splash waterproof** are the PolyGrip® blind rivets under certain conditions too. Hole filling and rest mandrel locking make of them a real alternative to closed end rivets when it is essential to prevent water flowing through the whole joint and not only through the rivet body.
- **A large closing head:** for a high tensile and unbuttoning resistance.



PolyGrip® blind rivets

High flexibility in design

The setting process of PolyGrip® blind rivets is fully predictable and the shaft deformation can be programmed for every special application through intelligent locating of the shaft grooves. This allows to reliably predetermine the clamp force, radial shaft expansion and closing head build-up.

The production of PolyGrip® blind rivets is one of the core specialities of the GESIPA® factory in Thal, Thuringia.



Alu/steel Standard

(Dome head)

Rivet body: Aluminium alloy
Mandrel: Steel, zinc-plated

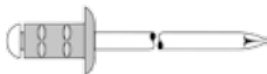

	Rivet body D ₁ x L mm	Grip range mm	Part no.	Quantity per box
3.2 Hole-Ø: 3.3 mm	3.2 x 8	0.5 - 5.0	143 3822	B 1000
	3.2 x 9,5	1.5 - 6.5	143 3823	"
	3.2 x 11	3.0 - 8.0	143 3824	"
4.0 Hole-Ø: 4.1 mm	4 x 10	0.5 - 6.5	143 3826	B 500
	4 x 13	3.5 - 9.5	143 3827	"
	4 x 17	7.0 - 13.0	143 3828	"
4.8 Hole-Ø: 4.9 mm CE	4.8 x 10	0.5 - 6.5	143 3831	B 500
	4.8 x 15	4.5 - 11.0	143 3832	"
	4.8 x 17	6.5 - 13.0	143 3833	"
	4.8 x 25	11.0 - 19.5	143 3838	B 250
6.4 Hole-Ø: 6.5 mm	6.4 x 15	1.5 - 9.0	143 3841	B 250
	6.4 x 20	6.0 - 14.0	143 3842	"
	6.4 x 25	10.0 - 18.0	143 3843	"

The information on shear and tensile strength, rivet pin diameters and the maximum setting head diameters can be found on page 51.

Under certain conditions all GESIPA® PolyGrip® blind rivets are splash waterproof.

PolyGrip® blind rivets

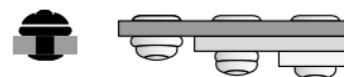

Alu/steel Countersunk (120°)

Rivet body: Aluminium alloy
Mandrel: Steel, zinc-plated



	Rivet body D ₁ x L mm	Grip range mm	Part no.	Quantity per box
3.2 Hole Ø: 3.3 mm	3.2 x 6	1.0 - 3.0	145 0404	B 1000
	3.2 x 10	4.0 - 7.0	145 0405	"
4.0 Hole Ø: 4.1 mm	4 x 6	1.5 - 3.5	145 0406	B 500
	4 x 12	3.5 - 8.5	144 6470	"
4.8 Hole Ø: 4.9 mm	4.8 x 10	2.0 - 5.0	145 0407	B 500
	4.8 x 15	5.0 - 11.0	144 6471	"

Alu/steel Large flange

Rivet body: Aluminium alloy
Mandrel: Steel, zinc-plated



	Rivet body D ₁ x L mm	Grip range mm	Part no.	Quantity per box
3.2 - K 9.5 Hole Ø: 3.3 mm	3.2 x 8	0.5 - 5.0	143 3825	B 1000
	3.2 x 9.5	1.5 - 6.5	145 5675	"
	3.2 x 11	3.0 - 8.0	145 5676	"
4.0 - K 12 Hole Ø: 4.1 mm	4 x 10	0.5 - 6.5	143 3829	B 500
	4 x 13	3.5 - 9.5	143 3830	"
	4 x 17	7.0 - 13.0	143 3837	"
4.8 - K 16 Hole Ø: 4.9 mm CE	4.8 x 10	0.5 - 6.5	143 3834	B 250
	4.8 x 15	4.5 - 11.0	143 3835	"
	4.8 x 17	6.5 - 13.0	143 3836	"
	4.8 x 25	11.0 - 19.5	143 3840	B 100
	4.8 x 30	16.0 - 24.0	145 5677	"

Alu/stainless Standard

(Dome head)

Rivet body: Aluminium alloy
Mandrel: Stainless steel A2

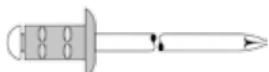

	Rivet body D ₁ x L mm	Grip range mm	Part no.	Quantity per box
3.2 Hole Ø: 3.3 mm	3.2 x 8	0.5 - 5.0	143 3883	B 1000
	3.2 x 9.5	1.5 - 6.5	143 3884	"
	3.2 x 11	3.0 - 8.0	143 3885	"
4.0 Hole Ø: 4.1 mm CE	4 x 10	0.5 - 6.5	143 3887	B 500
	4 x 13	3.5 - 9.5	143 3888	"
	4 x 17	7.0 - 13.0	143 3889	"
4.8 Hole Ø: 4.9 mm CE	4.8 x 10	0.5 - 6.5	143 3892	B 500
	4.8 x 15	4.5 - 11.0	143 3893	"
	4.8 x 17	6.5 - 13.0	143 3894	"
	4.8 x 25	11.0 - 19.5	143 3895	B 250
	4.8 x 30	16.0 - 24.0	143 3896	"
6.4 Hole Ø: 6.5 mm	6.4 x 15	1.5 - 9.0	143 3902	B 250
	6.4 x 20	6.0 - 14.0	143 3903	"
	6.4 x 25	10.0 - 18.0	143 3904	"

Material surcharge will be added at a daily rate.

PolyGrip® blind rivets



Alu/stainless Large flange

Rivet body: Aluminium alloy
Mandrel: Stainless steel A2

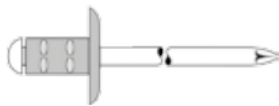

	Rivet body D1 x L mm	Grip range mm	Part no.	Quantity per box
3.2 - K 9.5 Hole Ø: 3.3 mm	3.2 x 8	0.5 - 5.0	145 6032	B 1000
	3.2 x 9.5	1.5 - 6.5	143 3886	"
	3.2 x 11	3.0 - 8.0	145 6033*	"
4.0 - K 12 Hole Ø: 4.1 mm CE	4 x 10	0.5 - 6.5	143 3890	B 500
	4 x 13	3.5 - 9.5	143 3891	"
	4 x 17	7.0 - 13.0	145 6034	"
4.8 - K 16 Hole Ø: 4.9 mm CE	4.8 x 10	0.5 - 6.5	143 3897	B 250
	4.8 x 15	4.5 - 11.0	143 3898	"
	4.8 x 17	6.5 - 13.0	143 3899	"
	4.8 x 25	11.0 - 19.5	143 3900	B 100
	4.8 x 30	16.0 - 24.0	143 3901	"

Material surcharge will be added at a daily rate.

Steel/steel Standard

(Dome head)

Rivet body: Steel, zinc-plated
Mandrel: Steel, zinc-plated



	Rivet body D1 x L mm	Grip range mm	Part no.	Quantity per box
3.2 Hole Ø: 3.3 mm	3.2 x 8	1.0 - 5.0	143 3866	B 1000
	3.2 x 9.5	2.0 - 6.5	143 3867	"
	3.2 x 11	3.0 - 8.0	143 3868	"
4.0 Hole Ø: 4.1 mm	4 x 10	1.5 - 6.5	143 3869	B 500
	4 x 13	4.5 - 9.0	143 3870	"
	4 x 17	8.5 - 13.0	143 3871	"
4.8 Hole Ø: 4.9 mm	4.8 x 10	1.5 - 6.5	143 3873	B 500
	4.8 x 15	6.0 - 11.0	143 3874	"
	4.8 x 17	8.5 - 13.0	143 3875	"
6.4 Hole Ø: 6.5 mm	6.4 x 15	2.0 - 8.0	143 3877	B 250
	6.4 x 20	5.0 - 13.0	143 3878	"
	6.4 x 25	10.0 - 18.0	143 3879	B 200

Steel/steel Countersunk (120°)

Rivet body: Steel, zinc-plated
Mandrel: Steel, zinc-plated

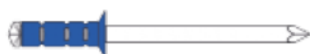

	Rivet body D1 x L mm	Grip range mm	Part no.	Quantity per box
3.2 Hole Ø: 3.3 mm	3.2 x 6	1.0 - 3.0	145 0435	B 1000
	3.2 x 10	3.0 - 7.0	145 0436	"
4.0 Hole Ø: 4.1 mm	4 x 6	1.5 - 3.5	145 0437	B 500
	4 x 12	3.5 - 8.5	144 6482	"
4.8 Hole Ø: 4.9 mm	4.8 x 10	2.0 - 6.0	144 6483	B 500
	4.8 x 15	5.5 - 11.0	144 6484	"

The information on shear and tensile strength, rivet pin diameters and the maximum setting diameters can be found on page 51.

*Clearance – only while stocks last!



PolyGrip® blind rivets

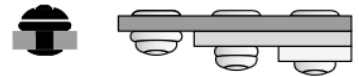

Steel/steel large flange

Rivet body: Steel, zinc-plated
Mandrel: Steel, zinc-plated

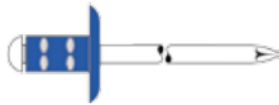

	Rivet body D1 x L mm	Grip range mm	Part no.	Quantity per box
3.2 - K 9.5 Hole Ø: 3.3 mm	3.2 x 8	1.0 - 5.0	145 5972	B 1000
	3.2 x 9.5	2.0 - 6.5	145 5973	"
	3.2 x 11	3.0 - 8.0	145 5974	"
4.0 - K 12 Hole Ø: 4.1 mm	4 x 10	1.5 - 6.5	143 3872	B 500
	4 x 13	4.5 - 9.0	145 5975	"
	4 x 17	8.5 - 13.0	145 5976	"
4.8 - K 16 Hole Ø: 4.9 mm	4.8 x 10	1.5 - 6.5	143 3876	B 250
	4.8 x 15	6.0 - 11.0	145 5977	"
	4.8 x 17	8.5 - 13.0	145 5978	"

A2 stainless steel Standard

Dome head

Rivet body: Stainless steel A2 -
no. 1.4567
Mandrel: Stainless steel A2

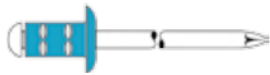

	Rivet body D1 x L mm	Grip range mm	Part no.	Quantity per box
3.2 Hole Ø: 3.3 mm	3.2 x 8	1.0 - 5.0	143 3909	B 1000
	3.2 x 9.5	2.0 - 6.0	145 6288	"
	3.2 x 11	3.0 - 8.0	143 3910	"
4.0 Hole Ø: 4.1 mm	4 x 10	1.0 - 6.5	143 3911	B 500
	4 x 13	3.0 - 8.0	143 3912	"
	4 x 17	7.0 - 11.0	143 3913	"
4.8 Hole Ø: 4.9 mm CE	4.8 x 10	1.0 - 6.5	143 3914	B 500
	4.8 x 15	5.0 - 10.0	143 3915	"
	4.8 x 17	8.0 - 12.0	143 3916	"
6.4 Hole Ø: 6.5 mm	6.4 x 13	2.0 - 6.5	143 3918	B 250
	6.4 x 15	3.5 - 8.5	143 3917	"
	6.4 x 20	7.0 - 12.5	143 3919	B 200

Material surcharge will be added at a daily rate.

A4 stainless steel Standard

Dome head

Rivet body: Stainless steel A4 -
no. 1.4578
Mandrel: Stainless steel A4



	Rivet body D1 x L mm	Grip range mm	Part no.	Quantity per box
3.2 Hole Ø: 3.3 mm	3.2 x 11	3.0 - 8.0	143 3921	B 1000
4.0 Hole Ø: 4.1 mm	4 x 10	1.0 - 6.5	143 3922	B 500
4.8 Hole Ø: 4.9 mm	4.8 x 10	1.0 - 6.5	143 3923	"
	4.8 x 15	5.0 - 10.0	143 3924	"

Material surcharge will be added at a daily rate.

PolyGrip® blind rivets

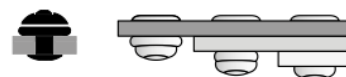

Monel® Standard

Rivet body: Nickel-copper-alloy
Mandrel: Stainless steel A2



	Rivet body D1 x L mm	Grip range mm	Part no.	Quantity per box
4.8 Hole-Ø: 4.9 mm	4.8 x 10	1.0 - 6.5	145 6335*	B 500
	4.8 x 15	5.0 - 10.0	145 6336*	"
	4.8 x 17	8.0 - 12.0	145 6337*	"

Material surcharge will be added at a daily rate.

*Clearance – only while stocks last!

Chart shear and tensile strength

PolyGrip® alu/steel and alu/stainless steel							
Rivet Ø mm	Shear strength		Tensile strength		Mandrel Ø mm	Max. head Ø mm standard	Max. head Ø mm Large flange
	N	(kp)	N	(kp)			
3.2	720	(73)	1,050	(107)	1.8	6.5	9.5
4.0	1,060	(108)	1,680	(171)	2.3	8.0	12.0
4.8	1,500	(163)	2,300	(231)	2.7	9.5	16.0
6.4	2,800	(285)	4,000	(405)	3.65	13.0	-

PolyGrip® steel/steel							
Rivet Ø mm	Shear strength		Tensile strength		Mandrel Ø mm	Max. head Ø mm standard	Max. head Ø mm Large flange
	N	(kp)	N	(kp)			
3.2	1,200	(122)	1,600	(163)	2.1	6.5	9.5
4.0	1,650	(168)	2,400	(245)	2.6	8.0	12.0
4.8	2,400	(245)	3,200	(326)	3.2	9.5	16.0
6.4	4,000	(408)	6,100	(621)	4.25	13.0	-

PolyGrip® stainless steel A2					
Rivet Ø mm	Shear strength		Tensile strength		Max. head Ø mm
	N	(kp)	N	(kp)	
3.2	1,450	(148)	2,300	(235)	6.5
4.0	2,650	(271)	3,600	(367)	8.0
4.8	4,000	(408)	5,000	(510)	9.5
6.4	7,800	(795)	8,800	(897)	13.0

PolyGrip® stainless steel A4					
Rivet Ø mm	Shear strength		Tensile strength		Max. head Ø mm
	N	(kp)	N	(kp)	
3.2	1,450	(148)	2,300	(235)	6.5
4.0	2,650	(271)	3,600	(367)	8.0
4.8	4,000	(408)	5,000	(510)	9.5

Monel®					
Rivet Ø mm	Shear strength		Tensile strength		Max. head Ø mm
	N	(kp)	N	(kp)	
4.8	3,500	(148)	4,500	(235)	9.5

Test procedure according to DIN EN ISO 14589

Coloured blind rivets

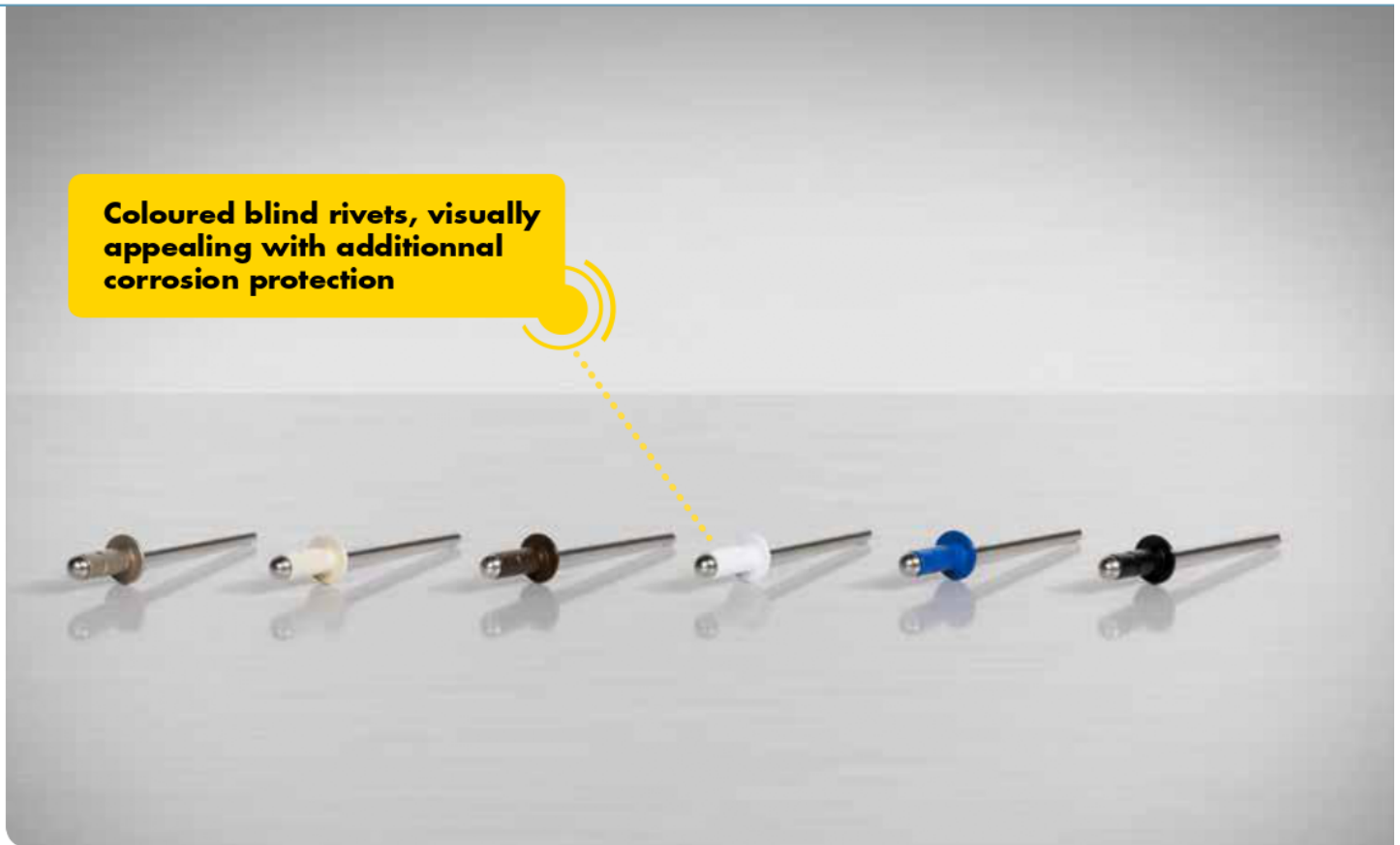

GESIPA® blind rivets are also available in colour to match the application.

To guarantee the best possible durability the hollow rivets are painted using a two-component epoxy resin paint in a stow enamelling process.

In addition to the visual benefits, the painted blind rivet also has added protection against corrosion. Aluminium blind rivets are best suited for this procedure. In the long-term they achieve the desired visual effect when joining coloured parts.

GESIPA® blind rivets are available in the standard RAL colours.

On request, steel blind rivets are also available in RAL colours or even special colours.

Another method for colouring blind rivets and for protecting them against corrosion is to anodize them. GESIPA® blind rivets are anodized in a direct current sulphuric acid process. The term Eloxal is used to describe the electrolytic oxidation of aluminium. Eloxal itself is actually colourless. Applying a second coat using metal salts creates the desired light-fast colour. The Eloxal method is more complex but is the most durable process for coloured blind rivets.

The range of coloured blind rivets includes **16 RAL colours** in ten different dimensions each. The blind rivets are produced in a wet varnish drum process. The colours are similar to the RAL colours.

The material surcharge will be added at a daily rate.

Coloured blind rivets – PolyGrip® in alu/stainless

Rivet body: Aluminium alloy
Mandrel: stainless steel A2

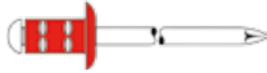

The material surcharge will be added at a daily rate.

	Rivet body D _i x L mm	Grip range mm	RAL 1015 Light ivory Part no.	RAL 1035 Pearl beige Part no.	RAL 3000 Flame red Part no.	RAL 5010 Gentian blue Part no.	RAL 7011 Iron grey Part no.	RAL 7016 Anthracit grey Part no.	Quantity per box
3.2 HoleØ: 3.3 mm	3.2 x 8	0.5 - 5.0	144 6485*	144 6488*	145 6047*	145 6055*	145 6063*	145 0448	A 1000
	3.2 x 9.5	1.5 - 6.5	145 6035*	144 6489*	144 6493*	145 6056*	145 6064*	145 0449	A 1000
	3.2 x 11	3.0 - 8.0	144 6486*	144 6490*	145 6048*	144 6495*	145 6065*	144 6510	A 1000
4 CE HoleØ: 4.1 mm	4 x 10	0.5 - 6.5	145 6036	145 6042*	145 6049	145 6057	145 6066	145 6159	B 500
	4 x 13	3.5 - 9.5	145 6037	144 6491*	145 6050	144 6496	145 6067	144 6511	B 500
	4 x 17	7.0 - 13.0	145 6038*	145 6043*	144 6494*	145 6058*	144 6497*	145 6160	B 500
4.8 HoleØ: 4.9 mm CE	4.8 x 10	0.5 - 6.5	145 6039	145 6044*	145 6051	145 6059	145 6068	145 0450	B 500
	4.8 x 15	4.5 - 11.0	145 6040	144 6492*	145 6052	145 6060	145 6069	145 6161	B 500
	4.8 x 17	6.5 - 13.0	144 6487	145 6045*	145 6053	145 6061	145 0447	145 6162	B 500
	4.8 x 25	11.0 - 19.5	145 6041	145 6046*	145 6054	145 6062	145 6070	144 6512	B 250

	Rivet body D _i x L mm	Grip range mm	RAL 7022 Umbra grey Part no.	RAL 7024 Graphite grey Part no.	RAL 8014 Sepia brown Part no.	RAL 9002 Grey white Part no.	RAL 9003 Signal white Part no.	Quantity per box
3.2 HoleØ: 3.3 mm	3.2 x 8	0.5 - 5.0	145 6071*	145 6079*	145 6088	145 6096	145 6106	A 1000
	3.2 x 9.5	1.5 - 6.5	145 6072*	145 6080*	145 6089	145 6097*	144 6503	A 1000
	3.2 x 11	3.0 - 8.0	145 6073*	145 6081*	144 6501	145 6098*	145 6107	A 1000
4 CE HoleØ: 4.1 mm	4 x 10	0.5 - 6.5	145 6074	145 6082	145 6090	145 6099	145 6108	B 500
	4 x 13	3.5 - 9.5	145 6075	145 6083	145 6091	145 6100	145 6109	B 500
	4 x 17	7.0 - 13.0	144 6498*	145 6084*	145 6092	145 6101	145 6110	B 500
4.8 HoleØ: 4.9 mm CE	4.8 x 10	0.5 - 6.5	145 6076*	145 6085	145 6093	145 6102	145 6111	B 500
	4.8 x 15	4.5 - 11.0	145 6077*	145 6086	145 6094	145 6103	144 6504	B 500
	4.8 x 17	6.5 - 13.0	145 6078	145 6087	145 6095*	145 6104*	145 6112	B 500
	4.8 x 25	11.0 - 19.5	144 6499	144 6500*	144 6502*	145 6105*	145 6113*	B 250

	Rivet body D _i x L mm	Grip range mm	RAL 9005 Jet black Part no.	RAL 9006 White aluminium Part no.	RAL 9007 Grey aluminium Part no.	RAL 9010 Pure white Part no.	RAL 9011 Graphite black Part no.	Quantity per box
3.2 HoleØ: 3.3 mm	3.2 x 8	0.5 - 5.0	145 6114	145 6124*	145 6131	145 6140	145 6150	A 1000
	3.2 x 9.5	1.5 - 6.5	145 6115	145 6125*	145 6132	145 6141	145 6151	A 1000
	3.2 x 11	3.0 - 8.0	145 6116	144 6505	145 6133	145 6142	145 6152	A 1000
4 CE HoleØ: 4.1 mm	4 x 10	0.5 - 6.5	145 6117	145 6126	145 6134	145 6143	145 6153	B 500
	4 x 13	3.5 - 9.5	145 6118	144 6506	145 6135	145 6144	145 6154	B 500
	4 x 17	7.0 - 13.0	145 6119	145 6127	144 6508	145 6145	145 6155	B 500
4.8 HoleØ: 4.9 mm CE	4.8 x 10	0.5 - 6.5	145 6120	145 6128	145 6136	145 6146	145 6156	B 500
	4.8 x 15	4.5 - 11.0	145 6121	145 6129	145 6137	145 6147	145 6157	B 500
	4.8 x 17	6.5 - 13.0	145 6122	145 6130	145 6138	145 6148	144 6509	B 500
	4.8 x 25	11.0 - 19.5	145 6123	144 6507*	145 6139	145 6149	145 6158*	B 250

The information on shear and tensile strength, rivet pin diameters and the maximum setting head diameters can be found on page 51.

*Clearance – only while stocks last!

SolarGrip® – the special rivet



IBC SOLAR AG, one of the world's leading global photovoltaic systems integrators, is investing in its cooperation with GESIPA®. GESIPA® has developed a blind rivet for the efficient IBC TopFix 200 assembly system that adequately meets the technical requirements, and has produced it in Germany.

The advantages are clear:

Fast and precise work, as well as tightness against splashing water at the riveting points, result in a durable and safe connection. We recommend using PowerBird® Solar or Accu-Bird® for quick and easy assembly. IBC Solar and GESIPA®, good connections are unbeatable.

What our client IBC SOLAR says about SolarGrip®:

„By offering our IBC TopFix 200 assembly system, we provide our customers with an assembly system for pitched roofs that is approved by the building inspectorate and ensures the highest level of flexibility and quality. IBC TopFix 200 is universally usable on any pitched roof and provides solutions for many different Types of roofs.

Specially-designed prefabricated module clamps are used for assembly on trapezoidal sheet metal roofs, which helps to save up to 20% of installation time compared to conventional assembly systems.

GESIPA® SolarGrip® rivets ensure quick, easy and safe assembly on the metal sheet. The rivet customised to our system and quality requirements guarantees water tightness, a long service life and the highest economic efficiency, and has proved itself in practice millions of times.

Many of our trade partners use SolarGrip® for convenient assembly of the substructure. The same also goes for the Haude family in Upper Franconia, Germany (see image). In 2015, the Haude family built their house in accordance with the latest energy efficiency principles, with the aim of avoiding primary energy from fossil fuels altogether. At the heart of the energy concept is a 9.7 kWp PV roof system. "To fix the assembly system to the trapezoidal sheet roof, we used pre-assembled clamps with SolarGrip® rivets – an impressive solution from our partner GESIPA®."

Sonnenstrom
mit System



SolarGrip® – the special rivet

Millions of connections exposed to storms, rain, snow and sunlight on a daily basis are testament to the reliability of GESIPA® SolarGrip® blind rivets, pictured on the left for application cases at IBC Solar.

Speak to us, we will be happy to advise you!



The perfect processing tool, the **PowerBird®-Solar**, can be found on **page 111**.

SolarGrip® – The solar fastener

- ETA-Approval applied for ETA-13/0255
- Matching grip range for many solar applications
- Ideal for working on trapezoid panel roofs
- SolarSeal coating for 4.8 mm rivets
- Riveting of sponge rubber or EPDM washers possible
- Function documentation available on request at extra cost

SolarGrip® – The basic characteristics

- Large grip range coverage with a single blind rivet
- Wide closing head
- Outstanding hole filling capability
- Compact closing head
- For use with all GESIPA® setting tools

SolarGrip® program

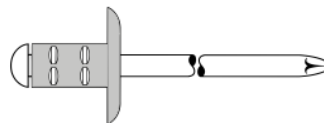

	Rivet body D ₁ x L mm	Material	Grip range mm	Tensile strength in N	Shear strength in N	Part no.	Quantity per box
4.8 - K 11.4 Hole Ø: 5.1 - 5.2 mm CE	4.8 x 12.0	Rivet body: Alu AlMg 2.5 (Colour: black) Mandrel: Stainless steel A2 – Nr. 1.4541	3.0 - 5.0	2,300	1,500	143 3905	P 500
	4.8 x 15.0	Rivet body: Alu AlMg 2.5 (blank) Mandrel: Stainless steel, zinc-plated	5.0 - 8.0	2,300	1,500	143 3906	"
6.4 - K 11.4 Hole Ø: 6.5 - 6.9 mm CE	6.4 x 14.0	Rivet body: Alu AlMg 2.5 (blank) Mandrel: Steel, zinc-plated	3.0 - 8.0	4,000	2,800	145 5678	P 250

*Material surcharge will be added at a daily rate

CE: ETA certification 13/0255

Corresponding approval documents on www.gesipa.com

All sizes on request – also available in bulk packs

GESIPA® CAP® – Closed end blind rivets



The structure

For technical reasons, the rivet mandrel of the GESIPA® CAP® blind rivet must be fixed in the rivet body. However this means that the rivet body can only deform slightly during the setting process. As a result, the cap blind rivet only has marginal hole filling capability. However this is necessary to be able to compensate large borehole tolerances.

Tight connections with care

The above-mentioned technical situations make careful preparation of the application imperative. The hole diameter should be as tight as possible to ensure a flawless function in the application for a long period.

If the GESIPA® CAP® blind rivet is processed carefully, it forms the basis for a reliably „tight“ connection.



GESIPA® CAP® – The closed end blind rivet

Alu/steel standard

Rivet body: Aluminium alloy
Mandrel: Steel, phosphate coated

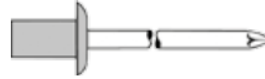

	Rivet body D1 x L mm	Grip range mm	Part no.	Quantity per box
3.2 Hole Ø: 3.3 mm	3.2 x 6.5	0.5 - 2.0	143 3423	A 500
	3.2 x 8.0	2.0 - 3.5	143 3424	"
	3.2 x 9.5	3.5 - 5.0	143 3425	"
	3.2 x 10.5	5.0 - 6.5	145 3876	"
	3.2 x 12.5	6.5 - 8.0	145 3877	"
4 Hole Ø: 4.1 mm	4 x 8.0	0.5 - 3.5	143 3431	B 500
	4 x 9.5	3.5 - 5.0	143 3432	"
	4 x 11.0	5.0 - 6.5	143 3433	"
	4 x 12.5	6.5 - 8.0	143 3434	"
	4 x 15.0	8.0 - 11.0	145 3878	"

	Rivet body D1 x L mm	Grip range mm	Part no.	Quantity per box
4.8 Hole Ø: 4.9 mm CE	4.8 x 8.0	1.0 - 3.5	143 3426	B 500
	4.8 x 9.5	3.5 - 5.0	143 3427	"
	4.8 x 11.0	5.0 - 6.5	143 3428	"
	4.8 x 12.5	6.5 - 8.0	143 3429	"
	4.8 x 14.0	8.0 - 9.5	143 3430	"
	4.8 x 16.0	9.5 - 11.0	145 3879	"
	4.8 x 18.0	11.0 - 13.0	143 3435	"
	4.8 x 21.0	13.0 - 16.0	143 3436	B 250

Alu/stainless steel standard

Rivet body: Aluminium alloy
Mandrel: Stainless steel



	Rivet body D1 x L mm	Grip range mm	Part no.	Quantity per box
3.2 Hole Ø: 3.3 mm	3.2 x 6.5	0.5 - 2.0	143 3437	A 500
	3.2 x 8.0	2.0 - 3.5	143 3438	"
	3.2 x 9.5	3.5 - 5.0	143 3439	"
	3.2 x 10.5	5.0 - 6.5	143 3440	"
4 Hole Ø: 4.1 mm	3.2 x 12.5	6.5 - 8.0	145 3890	"
	4 x 8.0	0.5 - 3.5	143 3441	B 500
	4 x 9.5	3.5 - 5.0	145 3891	"
	4 x 11.0	5.0 - 6.5	145 3892	"
	4 x 12.5	6.5 - 8.0	143 3442	"

	Rivet body D1 x L mm	Grip range mm	Part no.	Quantity per box
4.8 Hole Ø: 4.9 mm CE	4.8 x 8.0	1.0 - 3.5	143 3443	B 500
	4.8 x 9.5	3.5 - 5.0	143 3444	"
	4.8 x 11.0	5.0 - 6.5	143 3445	"
	4.8 x 12.5	6.5 - 8.0	143 3446	"
	4.8 x 14.0	8.0 - 9.5	143 3447	"
	4.8 x 16.0	9.5 - 11.0	143 3448	"
	4.8 x 18.0	11.0 - 13.0	143 3449	"
	4.8 x 21.0	13.0 - 16.0	143 3450	B 250

Material surcharge will be added at a daily rate

The information on shear and tensile strength, rivet pin diameters and the maximum setting head diameters can be found on page 59.

GESIPA® CAP® – The closed end blind rivet

A2 stainless steel standard

Rivet body: Stainless Steel A2 – no. 1.4301
Mandrel: Stainless Steel A1

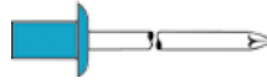

	Rivet body D1 x L mm	Grip range mm	Part no.	Quantity per box
3.2 Hole Ø: 3.3 mm	3.2 x 6.0	0.8 - 2.0	145 3899	A 500
	3.2 x 8.0	2.0 - 4.0	143 3452	"
	3.2 x 10.0	4.0 - 6.0	145 3900	"
	3.2 x 12.0	6.0 - 8.0	143 3453	"
4 Hole Ø: 4.1 mm	4 x 6.0	0.8 - 1.5	145 3901	A 500
	4 x 8.0	1.5 - 3.5	143 3454	"
	4 x 10.0	3.5 - 5.5	145 3902	B 500
	4 x 12.0	5.5 - 7.5	143 3455	"
	4 x 16.0	7.5 - 11.5	145 3903	"

	Rivet body D1 x L mm	Grip range mm	Part no.	Quantity per box
4.8 Hole Ø: 4.9 mm	4.8 x 8.0	0.8 - 3.0	143 3456	B 500
	4.8 x 10.0	3.0 - 5.0	143 3457	"
	4.8 x 12.0	5.0 - 7.0	143 3458	"
	4.8 x 16.0	7.0 - 11.0	143 3459	"
	4.8 x 20.0	11.0 - 15.0	143 3460	B 250

Material surcharge will be added at a daily rate
You have to expect limited jaw life.

Copper / steel standard

Rivet body: Copper alloy
Mandrel: Steel, lightly oiled

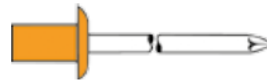

	Rivet body D1 x L mm	Grip range mm	Part no.	Quantity per box
3.2 Hole Ø: 3.3 mm	3.2 x 6.0	0.5 - 1.5	145 3904	A 500
	3.2 x 7.5	1.5 - 3.0	145 3905	"
	3.2 x 9.0	3.0 - 4.5	145 3906	"
	3.2 x 12.0	4.5 - 8.0	145 3907*	"
4 Hole Ø: 4.1 mm	4 x 9.5	1.0 - 4.5	145 3908	A 500
	4 x 11	4.5 - 6.0	145 0145*	B 500
	4 x 12.5	6.0 - 7.5	145 0146*	"
	4 x 15	7.0 - 10.5	145 0147*	"

	Rivet body D1 x L mm	Grip range mm	Part no.	Quantity per box
4.8 Hole Ø: 4.9 mm	4.8 x 8	0.5 - 1.5	145 0148*	B 500
	4.8 x 9.5	1.5 - 4.5	145 0149*	"
	4.8 x 11.5	3.5 - 6.5	145 3910*	B 500
	4.8 x 13.0	6.5 - 8.0	143 3461*	"
	4.8 x 15.0	8.0 - 9.5	145 3911*	"

*Clearance – only while stocks last!

GESIPA® CAP® – The closed end blind rivet

Copper / stainless standard



Rivet body: Copper alloy
Mandrel: Stainless steel

	Rivet body D1 x L mm	Grip range mm	Part no.	Quantity per box
3.2 Hole Ø: 3.3 mm	3.2 x 6.0	0.5 - 1.5	145 3913	A 500
	3.2 x 7.5	1.5 - 3.0	145 3914	"
	3.2 x 9.0	3.0 - 4.5	145 3915	"
4 Hole Ø: 4.1 mm	4 x 9.5	1.5 - 4.5	145 0152	B 500
	4 x 11	4.5 - 6.0	145 0153	"
	4 x 12.5	6.0 - 7.5	145 0154	"
	4 x 15	7.5 - 10.5	145 0155	"
4.8 Hole Ø: 4.9 mm	4.8 x 8	0.5 - 1.5	145 0156*	B 500
	4.8 x 9.5	1.5 - 4.5	145 0157*	"
	4.8 x 11.5	3.5 - 6.5	145 0158*	"
	4.8 x 13	6.5 - 8.0	145 0159*	"
	4.8 x 15	8.0 - 9.5	145 0160*	"

*Clearance – only while stocks last!

Material surcharge will be added at a daily rate

Chart shear and tensile strength

CAP® alu/steel and CAP® alu/stainless steel					
Rivet Ø	Shear strength		Tensile strength		Mandrel Ø
mm	N	(kp)	N	(kp)	mm
3.2	1,050	(107)	1,250	(127)	1.7
4.0	1,550	(158)	2,100	(214)	2.2
4.8	2,400	(245)	3,500	(356)	2.7

CAP®-A2 stainless steel					
Rivet Ø	Shear strength		Tensile strength		Mandrel Ø
mm	N	(kp)	N	(kp)	mm
3.2	1,900	(194)	2,400	(245)	1.9
4.0	2,900	(296)	3,700	(377)	2.3
4.8	4,300	(439)	5,400	(551)	2.9

CAP® copper/steel and CAP® copper/stainless steel					
Rivet Ø	Shear strength		Tensile strength		Mandrel Ø
mm	N	(kp)	N	(kp)	mm
3.2	1,000	(102)	1,400	(143)	1.7
4.0	1,500	(153)	2,200	(224)	2.2
4.8	2,100	(214)	3,100	(316)	2.7

Test procedure according to DIN EN ISO 14589

Special blind rivets

Special blind rivets for dedicated tasks

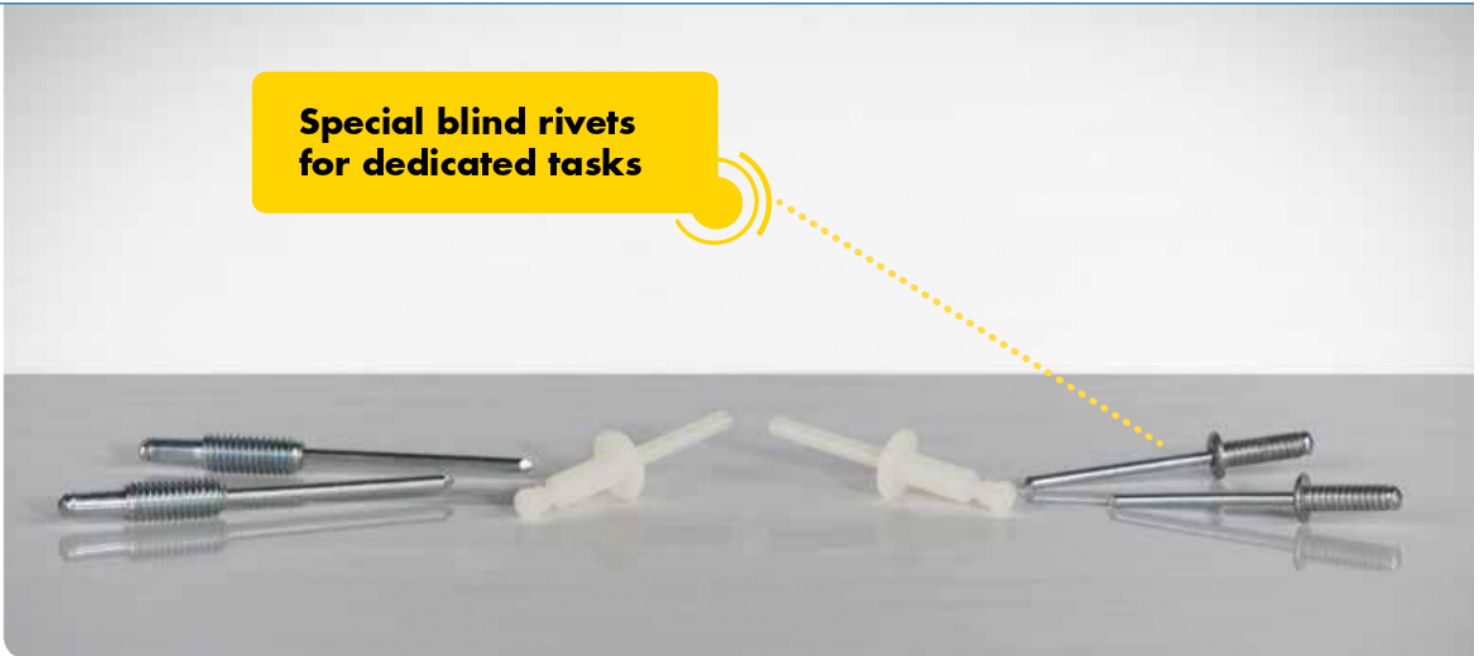

There are numerous applications that require the use of special blind rivets. For this reason GESIPA® has come up with some variations to meet these requirements.

Grooved blind rivets are suitable for riveting pocket holes in soft materials. They are used in the furniture industry, for interior construction, in the wood and plastics processing industry, in car body construction and lots more. Important: Before processing grooved blind rivets, the borehole diameter must be determined in trials and the minimum borehole depth must be observed.

Peel blind rivets are required if soft or porous parts such as wood, hard-fibre, fibreglass or plasterboards need to be joined together. In the setting process, the rivet mandrel falls out of the rivet body, and on the closing side the rivet mandrel splits the rivet shaft into four parts. These then grip into the material. Typical application fields are the assembly of plastic and wooden elements, caravan constructions and the attachment of interior panels.

The blind rivet connection itself is a permanent connection. However to attach further detachable parts, GESIPA® has the **threaded blind rivet** in its range. The threaded blind rivet has a stud bolt with an M5 or M6 outer thread to which other parts can be attached using an additional nut. The GESIPA® blind rivet stud range is listed on page 221 for parts that need greater clamping forces.

The **GESIPA®-clamp profile blind rivet** are excellently suited to comply with defined clearances when mounting parts or to set stoppers in rails. Accordingly, this special rivet is also used in the white goods and furniture industry.

Plastic rivets are free from corrosion, do not conduct electricity and do not damage varnished surfaces. They can be processed quickly and easily using GESIPA® manual blind rivet tools and automated riveting tools. The plastic blind rivets can be found in many trade sectors and their versatility makes them an interesting choice for a wide range of application possibilities.

Special blind rivets

Grooved alu/steel standard

Rivet body: Aluminium alloy
Mandrel: Steel, zinc-plated



(Dome head)

	Rivet body $D_1 \times L$ mm	max. thickness of material to be fixed mm	Part no.	Quantity per box
3.2 Hole-Ø: 3.4 mm	3.2 x 10	6	145 4100	A 500
	3.2 x 16	12	145 4101	"
4 Hole-Ø: 4.3 mm	4 x 8	4	145 4103	A 500
	4 x 12	8	145 4104	B 500
	4 x 16	12	145 4105	"

	Rivet body $D_1 \times L$ mm	max. thick- max. thickness of material to be fixed mm	Part no.	Quantity per box
4.8 Hole-Ø: 5.1 mm	4.8 x 10	6	145 4108	B 500
	4.8 x 14	10	145 4110	B 250
	4.8 x 18	13	145 4102	"
	4.8 x 25	20	145 4114*	"

*Clearance – only while stocks last!

Threaded steel/steel

Rivet body: Steel, zinc-plated
Mandrel: Steel, zinc-plated



Thread Hole Ø: 3.1 mm $G \times l$ mm	Rivet body $D_1 \times L$ mm	Grip range mm	Part no.	Quantity per box
M 5 x 10	3 x 6	0.5 - 3.0	145 5326	A 250
M 5 x 15	3 x 9	3.0 - 6.0	145 5327	"

Thread Hole Ø: 4.1 mm $G \times l$ mm	Rivet body $D_1 \times L$ mm	Grip range mm	Part no.	Quantity per box
M 6 x 10	4 x 5	1.0 - 2.0	145 5328	A 250
M 6 x 15	4 x 8	2.0 - 5.0	145 5329	"

Plastic standard

Rivet body: Polyamide, PA 6.6
Mandrel: Polyamide, PA 6.6



(Dome head)

	Rivet body $D_1 \times L$ mm	max. thick-ness of material to be fixed mm	Part no.	Quantity per box
4 Hole Ø: 4.1 mm	4 x 8	0.5 - 5.0	145 5337	B 500
	4 x 12	5.0 - 9.0	145 5338	"
5 Hole Ø: 5.1 mm	5 x 8	0.5 - 5.0	145 5339	B 500
	5 x 12	5.0 - 9.0	145 5340	"

	Rivet body $D_1 \times L$ mm	max. thick-ness of material to be fixed mm	Part no.	Quantity per box
6 Hole Ø: 6.1 mm	6 x 8	0.5 - 5.0	145 5341	B 250
	6 x 12	5.0 - 9.0	145 5342	"

Chart shear and tensile strength

Grooved Alu/Steel			
Rivet Ø mm	Shear strength N	Tensile strength (kp)	Mandrel Ø mm
3.2	720	(73)	950 (97)
4	1,400	(143)	2,000 (204)
4.8	1,800	(184)	2,700 (275)

Threaded Steel/steel		
Rivet Ø mm	Shear strength N	Mandrel Ø mm
3	1,100 (112)	1.95
4	2,000 (204)	2.5

Plastic		
Rivet Ø mm	Shear strength N	Mandrel Ø mm
4	180 (18)	2.5
5	290 (30)	3.0
6	440 (45)	3.5

Test procedure according to DIN EN ISO 14589

Special blind rivets

Peel alu/steel standard

Rivet body: Aluminium alloy
Mandrel: Steel, zinc-plated



	Rivet body D1 x L mm	Grip range mm	Part no.	Quantity per box
3.2 Hole Ø: 3.6 mm	3.2 x 10	2.5 - 5.0	145 5496	A 500
	3.2 x 12	4.5 - 7.0	143 3748	"
	3.2 x 16	6.5 - 11.0	145 5497	"
4 Hole Ø: 4.4 mm	4 x 8	1.0 - 3.0	145 5490	A 500
	4 x 10	2.5 - 5.0	145 5494	B 500
	4 x 12	4.5 - 6.5	145 5491	"
	4 x 14	6.0 - 8.0	145 5492	"
	4 x 16	7.5 - 10.0	143 3740	"
	4 x 18	9.0 - 12.0	143 3741	"
	4 x 20	11.5 - 14.0	145 5493	"

	Rivet body D1 x L mm	Grip range in mm	Part no.	Quantity per box
4.8 Hole Ø: 5.2 mm	4.8 x 10	2.5 - 5.0	143 3747	B 500
	4.8 x 12	4.5 - 7.0	143 3742	"
	4.8 x 14	6.5 - 9.0	143 3743	B 250
	4.8 x 16	8.5 - 10.0	143 3744	"
	4.8 x 18	9.5 - 12.0	143 3746	"
	4.8 x 20	11.5 - 14.0	143 3745	"
	4.8 x 25	13.5 - 19.0	143 3749	"

Chart shear strength

Peel alu/steel			
Rivet Ø mm	Shear strength N	Mandrel-Ø mm	Max. head Ø mm
3.2	700	(81)	1.95
4	1,200	(143)	2.1
4.8	1,700	(204)	2.7

Test procedure according to DIN EN ISO 14589

Profile clinching rivets alu/steel

Rivet body: Aluminium alloy
Mandrel: Steel, zinc-plated

Profile Type Hole Ø: 3.1 mm	Rivet body Ø x L mm	Grip range in mm	Part no.	Quantity per box
HA	3 x 5	1.0 - 2.5	145 3916	A 500
HA	3 x 7	2.5 - 4.5	145 3917*	"
HB	3 x 5	1.0 - 2.5	145 3918	A 500
HB	3 x 7	2.5 - 4.5	145 3919	"
W	3 x 5	1.0 - 2.5	145 3920	A 500
A	4 x 7	1.0 - 4.0	145 3921	B 500
BR	4 x 7	1.0 - 4.0	145 3922	"
C	4 x 7	1.0 - 4.0	145 3923	"
KF	4 x 7	1.0 - 4.0	145 3924*	"

Chart shear strength

Profile clinching alu/steel			
Rivet Ø mm	Shear strength N	Mandrel Ø mm	
3	450	(46)	1.8
4	850	(87)	2.1

Test procedure according to DIN EN ISO 14589

*Clearance – only while stocks last!



TYP HA



TYP HB



TYP W



TYP A



TYP BR



TYP C



TYP KF

G-Bulb blind rivets

G-Bulb - high strength blind rivets - in carbon steel and stainless steel



G-Bulb blind rivet

GESIPA® has developed a new range of high strength structural blind rivets called G-Bulb with diameters of 4.8 and 6.4 mm in steel and A2 stainless steel, to fit grip ranges from 1.5 up to 15.5 mm.

The G-Bulb rivet features a wide grip range, together with high shear and tensile strengths generated by the rivet function, the formation of a large closing head and the mechanical lock of the rest mandrel in the rivet body.

In combination with the patented function crimping on the rivet body, the G-Bulb provides tight and sealed joints in a large variation of hole sizes.

The G-Bulb rivet generates a large closing head which transfers high strain and clamping load to the application. With a mandrel breakload of max. 16 kN, the G-Bulb rivets can be installed with standard tooling.



G-Bulb – high strength blind rivets

The setting process

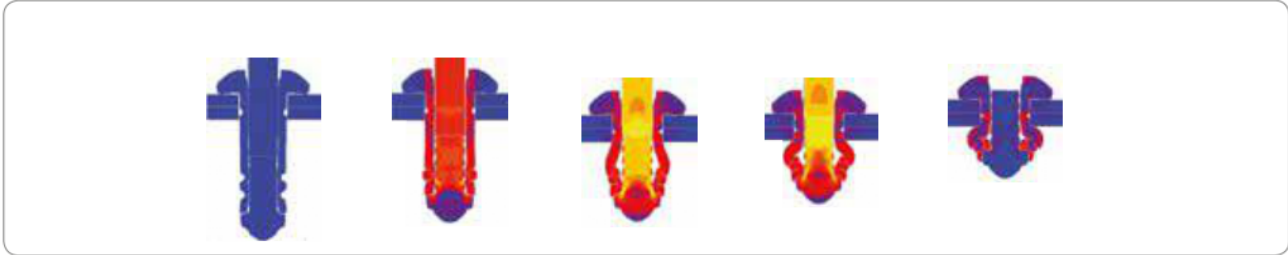

Main features

- Excellent hole filling capability
- High clamping force
- Excellent tensile strength through large closing head
- Excellent shear strength through mandrel locking
- Processing with standard setting tools
- Process control compatible with the TAURUS® C
- RoHS compliant

Materials

Rivet body: Steel, zinc plated CrVI-free, or stainless steel A2 no. 1.4567, Mandrel: Steel, zinc plated CrVI-free, or stainless steel A2 no. 1.4541
Other surface treatments on request



Steel/steel

Dome head

Rivet body: Steel, zinc-plated
Mandrel: Steel, zinc-plated



	Rivet body D, x L mm	Grip range mm	Part no.	Quantity per box
4.8	4.8 x 10	1.5 - 3.5	143 3925	B 500
	4.8 x 13	3.5 - 6.0	143 3926	"
	4.8 x 15	6.0 - 8.0	143 3927	"
6.4 Hole-Ø: 6.7 - 6.9 mm	6.4 x 13	2.0 - 4.5	143 3928	B 250
	6.4 x 17	4.5 - 7.0	143 3929	"
	6.4 x 20	7.0 - 10.5	143 3930	B 200
	6.4 x 23	10.5 - 13.0	143 3931	B 150
	6.4 x 25	13.0 - 15.5	143 3932	"

Further dimensions and surface treatments on request

G-Bulb – high strength blind rivets

A2 stainless steel *Dome head*

Rivet body: Stainless steel A2 –no. 1.4567

Mandrel: Stainless steel A2



	Rivet body D1 x L mm	Grip range mm	Part no.	Quantity per box
4.8 CE Hole- \varnothing : 5.0 - 5.2 mm	4.8 x 10	1.5 - 3.5	145 6426	B 500
	4.8 x 13	3.5 - 5.5	145 6427	"
	4.8 x 15	5.5 - 7.5	143 3936	"
6.4 Hole- \varnothing : 6,7 - 6,9 mm CE	6.4 x 13	2.0 - 4.0	143 3937	B 250
	6.4 x 15	4.0 - 6.0	143 3938	"
	6.4 x 17	6.0 - 8.0	143 3939	"
	6.4 x 20	8.0 - 10.5	143 3940	B 200
	6.4 x 23	10.5 - 12.5	143 3941	B 150
	6.4 x 25	12.5 - 14.5	143 3942	B 150

Material surcharge will be added at a daily rate

Further dimensions and surface treatments on request

Chart shear and tensile strength

G-Bulb steel/steel						
Rivet \varnothing mm	Shear strength N	(kp)	Tensile strength N	(kp)	Mandrel \varnothing mm	Max. head \varnothing mm
4.8 x 10	3,600	(367)	3,500	(357)	3.2	9.5
4.8 x 13	4,000	(408)	3,500	(357)	3.2	9.5
4.8 x 15	5,600	(571)	3,500	(357)	3.2	9.5
6.4 x 13	8,500	(867)	8,000	(816)	4.25	13.0
6.4 x 17	10,000	(1,019)	8,000	(816)	4.25	13.0
6.4 x 20	11,000	(1,120)	8,000	(816)	4.25	13.0
6.4 x 23	11,000	(1,120)	8,000	(816)	4.25	13.0
6.4 x 25	11,000	(1,120)	8,000	(816)	4.25	13.0

G-Bulb A2 stainless steel						
Rivet \varnothing mm	Shear strength N	(kp)	Tensile strength N	(kp)	Mandrel \varnothing mm	Max. head \varnothing mm
4.8 x 10	4,400	(431)	5,400	(550)	3.2	9.5
4.8 x 13	4,550	(446)	5,400	(550)	3.2	9.5
4.8 x 15	4,700	(461)	5,400	(550)	3.2	9.5
6.4 x 13	8,000	(816)	8,800	(897)	4.25	13.0
6.4 x 15	10,000	(1.019)	8,800	(897)	4.25	13.0
6.4 x 17	10,000	(1.019)	8,800	(897)	4.25	13.0
6.4 x 20	11,000	(1.120)	8,800	(897)	4.25	13.0
6.4 x 23	11,000	(1.120)	8,800	(897)	4.25	13.0
6.4 x 25	11,000	(1.120)	8,800	(897)	4.25	13.0

Test procedure according to DIN EN ISO 14589

PolyBulb® blind rivets

Large disc-shaped bulb formation – perfect for sensitive applications with both soft and brittle materials.



Disc-shaped closing head

This practical closing head shape evenly distributes the contact pressure over the component, making it the perfect joining element for riveting both soft and brittle components such as plastics and composite materials. The PolyBulb® blind rivet leaves an aesthetic setting appearance.



Large grip range

A PolyBulb® blind rivet replaces up to 3 conventional blind rivets, thus reducing parts diversity. Combining several dimensions saves handling and storage costs while additionally reducing the risk of mix-up at the workplace and subsequent quality problems.

Controlled hole filling

With hole filling capabilities adapted to requirements, the PolyBulb® blind rivet provided an optimum joint.

Advantages

- Large grip range
- **Disc-shaped** closing head with large closing head \varnothing
- Aesthetic setting appearance, only one distinct closing head
- High tensile strength and detachment force (especially with plastic joining material)
- Controlled hole filling
- Excellent grip properties
- Locked mandrel
- Non-rattling
- Process control capabilities



PolyBulb® blind rivets

Alu/steel Dome head

Rivet body: Aluminium alloy
Mandrel: Steel, zinc-plated

	Rivet body D _i x L mm	Grip range mm	Part no.	Quantity per box
4.8 Hole-Ø: 4.9 mm - 5.1 mm	4.8 x 11	1.5 - 6.0 *	145 0473	B 250
	4.8 x 16	6.0 - 10.0 *	145 0474	B 250

Chart shear and tensile strength

alu/steel				
Rivet Ø mm	Shear strength N (kp)	Tensile strength N (kp)	Mandrel Ø mm	Max. head Ø mm
4.8 x 11	1,450 (148)	1,900 (194)	~3.0	10.0
4.8 x 16				

*Reference value that changes depending on the hole diameter and the material to be riveted.

MEGA GRIP® blind rivets

**GESIPA®-MEGA GRIP® –
High strength blind rivets
with large grip range and
optimal cost effectiveness**



MEGA GRIP® blind rivets – Perfect efficiency

The GESIPA® MEGA GRIP® is a high strength structure blind rivet with a very large grip range. The variable grip range allows efficient use and, owing to the merging of up to five blind rivet lengths into one MEGA GRIP® dimension, reduces the handling costs.

MEGA GRIP® blind rivets – The setting process

During the setting process, the hollow mandrel head presses the rivet body with great force against the rivet hole. The radial deformation here ensures that an above-average, large clamping area is covered. The stable position of the rivet mandrel throughout the entire setting process guarantees compliance with the high shear force through double locking. The excellent hole filling capability also protect ideally against splash-water.

MEGA GRIP® blind rivets – Standard or special production?

The GESIPA® MEGA GRIP® is available in a flat Round head or recessed head form and comes in the material combinations alu/alu or steel/steel as standard. Supplied in large or small packages, the MEGA GRIP® is always available in the quantity required. We can supply special dimensions on request.

The advantages

- Perfectly splash proof
- Efficient use with large grip range coverage
- High shear strength due to double rest mandrel locking
- Outstanding hole filling capability
- Flush removal on the setting head without sharp edges.

Please note that to achieve the best possible values from the GESIPA®-MEGA GRIP®, use of special tools/nosepieces is required.

MEGA GRIP® blind rivets are available in small packs, too!



MEGA GRIP® blind rivets

Alu/alu

Dome head

Rivet body: Aluminium alloy
Mandrel: Aluminium alloy

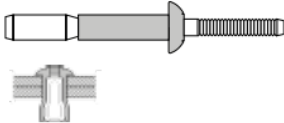

	Rivet body D1 x L mm	Grip range mm	Type	Part no. bulk pack	Quantity per box	Part no. small pack	Quantity per box
4.8 Hole-Ø: 4.9 - 5.2 mm	4.8 x 10.0	1.6 - 6.4	RV6900-6-4	143 3805	5,000	143 3808	B500
	4.8 x 14.0	1.6 - 11.1	RV6900-6-7	145 5654	3,000	143 3809	B250
6.4 Hole-Ø: 6.6 - 6.9 mm	6.4 x 14.1	2.0 - 9.5	RV6900-8-6	143 3806	2,000	143 3810	B200
	6.4 x 20.5	2.0 - 15.9	RV6900-8-10XG	143 3807	1,500	143 3811	B100

Steel/steel

Dome head

Rivet body: Steel, zinc-plate
Mandrel: Steel, zinc-plated

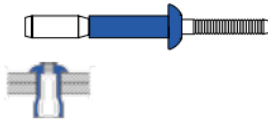

	Rivet body D1 x L mm	Grip range mm	Type	Part no. bulk pack	Quantity per box	Part no. small pack	Quantity per box
4.8 Hole-Ø: 4.9 - 5.2 mm	4.8 x 10.0	1.6 - 6.4	RV6977-6-4	143 3812	5,000	143 3816	B500
	4.8 x 14.0	1.6 - 11.1	RV6977-6-7	145 5657	3,000	143 3817	B250
6.4 Hole-Ø: 6.6 - 6.9 mm	6.4 x 14.1	2.0 - 9.5	RV6977-8-6	143 3813	2,000	145 5663	B200
	6.4 x 19.6	2.0 - 15.9	RV6977-8-10XG	143 3814	1,500	143 3818	B100

Steel/steel

Countersunk

Rivet body: Steel, zinc-plated
Mandrel: Steel, zinc-plated

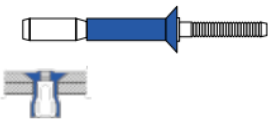

	Rivet body D1 x L mm	Grip range mm	Type	Part no. bulk pack	Quantity per box	Part no. small pack	Quantity per box
4.8 Hole-Ø: 4.9 - 5.2 mm	4.8 x 10.0	2.6 - 6.4	RV6177-6-5	145 5658	3,500	145 5660	B250
	4.8 x 14.0	5.5 - 11.1	RV6177-6-8	145 5659	2,500	145 5661	B250
6.4 Hole-Ø: 6.6 - 6.9 mm	6.4 x 15.8	3.0 - 11.1	RV6177-8-7	143 3815	2,000	145 5662	B200

Chart shear and tensile strength

MEGA GRIP® Alu/alu				
Rivet Ø mm	Shear strength N (kp)	Tensile strength N (kp)	Mandrel-Ø mm	Max. head Ø mm
4.8	3,330 (340)	2,400 (245)	2.95	9.5
6.4	5,910 (600)	4,450 (450)	3.9	12.7

MEGA GRIP® Steel/steel				
Rivet Ø mm	Shear strength N (kp)	Tensile strength N (kp)	Mandrel-Ø mm	Max. head Ø mm
4.8	6,850 (700)	4,500 (460)	2.95	9.5
6.4	12,500 (1.275)	8,200 (835)	3.9	12.7

Test procedure according to DIN EN ISO 14589

BULB-TITE® blind rivets

Strong in demanding applications requiring perfect clamp force and weatherproofness



Originally designed for the construction industry, the GESIPA®-BULB-TITE® rivets have proven their worth in many other application fields thanks to their multifunctional properties. The majority of the BULB-TITE® program has been approved by the „Deutsches Institut für Bau-technik“ in Berlin thereby guaranteeing extra security when used in steel constructions or on facades.

BULB-TITE® blind rivets – Powerful wherever used

Thanks to the shear zone overlap of the BULB-TITE®-rivet mandrel in the application, permanent and very high shear forces can be achieved.

BULB-TITE® blind rivets – Weather resistance

The use of a special nosepiece when processing the BULB-TITE®-rivet locks the mandrel into the sealing part on the setting head side to prevent dirt and/or damp penetrating the application. The sealing washer, which is available as an optional accessory, offers added protection against wet and damp below the closing head.

BULB-TITE® blind rivets – Excellent clamping force

The three large pressure plates distribute the clamping forces evenly across a large area of the surface so that even soft, thin, supple or brittle materials can be riveted safely without destroying or damaging the surface.

BULB-TITE® blind rivets – Complex applications

BULB-TITE®- rivets also guarantee a safe function where other rivets have already given up. The three plates of the closing head adapt and form to fit even curved application surfaces so that safe riveting is possible even on pipes, beads and other unusually formed applications.

Please note that to achieve the best possible values from the GESIPA®-BULB-TITE®, use of special tools/nosepieces is required.

BULB-TITE® blind rivets are available in small packs, too!



BULB-TITE® blind rivets

BULB-TITE® blind rivets – Multi-Grip

GESIPA®-BULB-TITE® rivets cover larger clamping ranges. Less dimensions are required thereby reducing handling and warehouse costs.

BULB-TITE® blind rivets – Application areas

Facades, shipbuilding, containers, truck and passenger busses production, trailers, trapezoidal sheet metal roof

BULB-TITE® blind rivets – The advantages

- Large grip range
- Vibration-proof
- Use on straight and curved application parts
- Waterproof with neoprene sealing washer
- Large distribution of the grip force over a large surface

Alu/alu Dome head

Rivet body: Aluminium alloy
Mandrel: Aluminium alloy

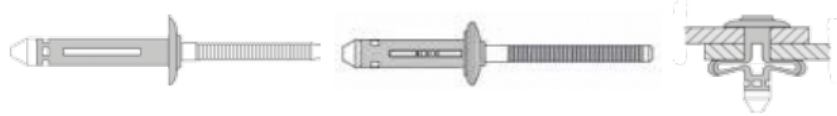

	Rivet body D ₁ x L mm	Grip range mm	Type	Part no. bulk pack	Quantity per box	Part no. small pack	Quantity per box
4 Hole Ø: 4.1 - 4.2 mm	4 x 25.1	6.4 - 12.7	RV 6604-5-8	145 5570*	3,500	-	-
5.2 Hole Ø: 5.3 - 5.5 mm	5.2 x 17.5	1.3 - 4.8	RV 6604-6-3	145 5571*	3,000	-	B 250
	5.2 x 19.1	1.6 - 6.4	RV 6604-6-4	145 5572	"	145 5606	"
	5.2 x 22.2	4.7 - 9.5	RV 6604-6-6	145 5573*	"	145 5607*	"
	5.2 x 31.8	14.3 - 19.1	RV 6604-6-12	145 5576*	"	145 5610*	B 200
	5.2 x 34.9	17.4 - 22.2	RV 6604-6-14	145 5577*	1,500	145 5611*	B 150
	5.2 x 38.1	20.6 - 25.4	RV 6604-6-16	145 5578*	"	145 5612*	"
with EPDM washer CE	5.2 x 17.5	0.5 - 4.8	RV 6604-6-3 W	143 3799	3,000	145 5620	B 250
	5.2 x 19.1	1.6 - 6.4	RV 6604-6-4 W	145 5586	"	145 5621	"
	5.2 x 22.2	4.7 - 9.5	RV 6604-6-6 W	145 5587	"	145 5622	"
	5.2 x 25.4	7.9 - 12.7	RV 6604-6-8 W	145 5588	"	145 5623	"
	5.2 x 31.8	14.3 - 19.1	RV 6604-6-12 W	-	"	145 5625*	"
	5.2 x 34.9	17.4 - 22.2	RV 6604-6-14 W	145 5590*	1,500	145 5626*	B 150
	5.2 x 38.1	20.6 - 25.4	RV 6604-6-16 W	145 5591*	"	145 5627*	"
	5.2 x 41.3	23.8 - 28.6	RV 6604-6-18 W	145 5592*	"	145 5628*	"

*Clearance – only while stocks last!



The information on shear and tensile strength, rivet pin diameters and the maximum setting head diameters can be found on page 73.

BULB-TITE® blind rivets

Alu/alu Dome head

Rivet body: Aluminium alloy
Mandrel: Aluminium alloy



	Rivet body D1 x L mm	Grip range mm	Type	Part no. bulk pack	Quantity per box	Part no. small pack	Quantity per box
6.3 Hole Ø: 6.4 - 6.6 mm	6.3 x 23.4	3.2 - 9.5	RV 6604-8-6	-	-	145 5615*	B 200
	6.3 x 26.5	6.4 - 12.7	RV 6604-8-8	145 5582*	2,000	145 5616	"
	6.3 x 29.7	9.5 - 15.9	RV 6604-8-10	145 5583*	1,500	145 5617*	B 150
6.3  Hole Ø: 6.4 - 6.6 mm with EPDM washer	6.3 x 20.2	1.6 - 6.4	RV 6604-8-4 W	145 5593	2,000	145 5629	B 200
	6.3 x 23.4	3.2 - 9.5	RV 6604-8-6 W	145 5594	"	145 5630	"
	6.3 x 29.7	9.5 - 15.9	RV 6604-8-10 W	145 5596*	1,500	145 5631*	B 150
7,7  Hole Ø: 7.8 - 8,2 mm with EPDM washer	7.7 x 27.7	1.0 - 9.5	RV 6603-9-6 W	145 5597	"	145 5632	"

Alu/alu Large flange

Rivet body: Aluminium alloy
Mandrel: Aluminium alloy



	Rivet body D1 x L mm	Grip range mm	Type	Part no. bulk pack	Quantity per box	Part no. small pack	Quantity per box
7.7 - K19 Hole Ø: 7.8 - 8.2 mm with EPDM washer 	7.7 x 27.7	1.1 - 9.5	RV 6605-9-6 W	143 3801	1,000	145 5633	B 100
	7.7 x 34.0	6.4 - 15.9	RV 6605-9-10 W	146 4000	1,000	145 5634	B 100

Steel/steel Round head

Rivet body: Steel, zinc-plated
Mandrel: Steel, zinc-plated



	Rivet body D ₁ x L mm	Grip range mm	Type	Part no. bulk pack	Quantity per box	Part no. small pack	Quantity per box
6.3 Hole-Ø: 6.4 - 6.6 mm	6.3 x 20.2	1.0 - 6.4	RV6676-8-4	145 5641*	1,500	145 5649*	B 100
	6.3 x 23.4	3.2 - 9.5	RV6676-8-6	145 5642*	"	145 5650*	"

*Clearance – only while stocks last!

BULB-TITE® blind rivets

Steel/steel Dome head

Rivet body: Steel, zinc-plated
Mandrel: Steel, zinc-plated



	Rivet body D ₁ x L mm	Grip range mm	Type	Part no. bulk pack	Quantity per box	Part no. small pack	Quantity per box
5.2 Hole Ø: 5.3 - 5.5 mm	5.2 x 19.1	1.6 - 6.3	RV 6674-06-04	-	-	145 5643*	B 150
with EPDM washer	5.2 x 19.1	1.6 - 6.3	RV 6674-06-04 W	144 6464	A 1.500	145 5645	"
	5.2 x 22.3	4.8 - 9.5	RV 6674-06-06 W	144 6465	"	145 5646	"
	5.2 x 25.4	7.9 - 12.7	RV 6674-06-08 W	145 0399	"	144 6468	"
	5.2 x 28.6	11.1 - 15.8	RV 6674-06-10 W	144 6466	"	144 6469	"
	5.2 x 31.8	14.3 - 19.0	RV 6674-06-12 W	144 6467	"	145 5647	"

*Clearance – only while stocks last!

Monel®/stainless steel

Round head

Rivet body: Monel®
Mandrel: Stainless steel



	Rivet body D ₁ x L mm	Grip range mm	Type	Part no. bulk pack	Quantity per box	Part no. small pack	Quantity per box
6.3 CE Hole-Ø: 6.4 - 6.6 mm	6.3 x 20.2	1.0 - 6.4	RV6696-8-4	143 3804*	1,500	145 5651*	B 100

*Clearance – only while stocks last!

Material surcharge will be added at a daily rate

Chart shear and tensile strength

BULB-TITE® alu/alu						
Rivet Ø mm	Shear strength N	(kp)	Tensile strength N	(kp)	Mandrel Ø mm	Max. head Ø mm
4	2,000	(210)	1,050	(110)	2.4	9.0
5.2	2,700	(284)	1,950	(198)	2.9	11.7
6.3	4,200	(500)	2,500	(305)	3.9	14.5
7.7	6,650	(680)	4,850	(500)	4.5	15.9
7.7 K19	6,650	(680)	4,850	(500)	4.5	19.3
BULB-TITE® steel/steel						
Rivet Ø mm	Shear strength N	(kp)	Tensile strength N	(kp)	Mandrel Ø mm	Max. head Ø mm
5.2	3,890	(396)	2,890	(294)	3.0	11.7
6.3	5,550	(565)	4,200	(428)	3.9	14.5
Monel®/stainless steel						
Rivet Ø mm	Shear strength N	(kp)	Tensile strength N	(kp)	Mandrel Ø mm	Max. head Ø mm
6.3	8,220	(565)	6,470	(428)	3.9	14

BULB-TITE® blind rivets are available in small packs, too!

TRI-FOLD® folding type blind rivets

TRI-FOLD® folding Type blind rivets – for soft and porous application materials



The function

The GESIPA® TRI-FOLD® blind rivet forms three press lashes on the closing head side during setting.

Thanks to its special design, the TRI-FOLD® is also able to compensate over-dimensional or irregular drill hole diameters.

The advantages

The large moulded lashes distribute the exerted clamping force evenly and gently onto the riveted material. Also, the large surface of the lashes offer excellent protection against the rivet being pulled through very soft, porous or brittle application parts.

Application areas

TRI-FOLD® blind rivets are excellently suited for the automotive field, e.g. for plastic panelling, car body parts and for the interior work inside vehicles, but also for all other applications that are particularly soft, brittle, easily deformed or porous.

Alu/alu

Dome head

Rivet body: Aluminium alloy
Mandrel: Aluminium alloy



	Rivet body D, x L mm	Grip range mm	Type	Part no.	Quantity per box
4.1 Hole Ø: 4.2 mm	4.1 x 21.1	1.0 - 9.5	GAMD56ATF	143 3820*	B 500
	4.1 x 24.3	3.2 - 12.7	GAMD58ATF	145 5667*	B 500
4.8 Hole Ø: 4.9 mm	4.8 x 19.0	1.6 - 6.3	GAMD64ATF	143 3821	B 250
	4.8 x 22.2	4.7 - 9.5	GAMD66ATF	145 5668	B 250
	4.8 x 25.4	7.9 - 12.7	GAMD68ATF	145 5669	B 250
	4.8 x 28.5	11.1 - 15.9	GAMD610ATF	145 5670*	B 250
	4.8 x 31.7	14.2 - 19.0	GAMD612ATF	145 5671*	A 100

*Clearance – only while stocks last!

Chart shear and tensile strength

TRI-FOLD® alu/alu					
Rivet Ø	Shear strength		Tensile strength		Mandrel Ø
mm	N	(kp)	N	(kp)	mm
4.1	650	(66)	850	(87)	2.4
4.8	1,100	(112)	1,400	(143)	2.9
					Max. head Ø mm
					8.2
					10.1

Test procedure according to DIN EN ISO 14589

Solid Riveting

Solid and semitubular rivets as the more light-weight and cost-effective alternative to screws/nuts for strong and quality connections



Solid and semitubular rivets

GESIPA® Solid Riveting develops and produces solid and semitubular rivets. These joining elements are a technical and efficient alternative to screw connections or other joining systems. Different dimensions, materials and head shapes cover a wide range of applications. Ideas backed by 60 years of experience – GESIPA® as a development partner provides technical advice and finds the most cost effective joining solution for your application.

Main features

- Reduced overall costs compared to screw connections
- No relative movements, e.g. hole filling capabilities
- Permanent connection
- High endurance strength
- Corrosion protection with our own Sherard or SheraBlack® process*

Advantages

Application-related consultation accompanied by in-house tests make the "solid rivets" fully definable so that they can be adapted to any application with our rivet specification:

- Shear force
- Tensile force
- Grip force
- Corrosion resistance: unriveted and riveted

*Standard Sherard and SheraBlack® are internal corrosion protection processes. In a diffusion galvanisation process, a corrosion-resistant iron-zinc coating is applied and is suitable for all grades of cast iron and steel.

This process provides the following benefits:

- No hydrogen embrittlement
- Outstanding wear resistance
- Temperature resistance up to 600 °C
- Uniform layer thickness distribution
- Good paintability
- Free of Cr-VI
- Bulb surface not damaged during riveting process
- 720 h DIN EN ISO 9277 NSS/2 cycles DIN 50018 KFW 2.0 S
- After riveting: 168 (720) h DIN EN ISO 9277 NSS
- Black surface

Example of slot riveting with optimum filling.



Cordless blind rivet setting tools

Blind rivet hand tools

78



80

NTS



81

NTX & NTX-F



82

Flipper®



84

Flipper® Plus



86

HN2

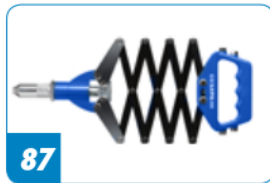

87

SN2

Battery powered blind rivet setting tools

88



90

iBird® Pro



94

AccuBird® Pro



96

PowerBird® Pro



98

PowerBird® Pro Gold Edition



100

Pro series with spring-loaded trigger system



105

AccuBird®



108

PowerBird®



111

PowerBird® Solar

What rivets what?

Tool	Energy	Ø mm								
		2.4	3.0	3.2	4.0	4.8	5.0	6.0	6.4	8.0
NTS, NTX, NTX-F, Flipper®, Flipper® Plus	H					A	A			
HN2, SN2	H									
AccuBird®, AccuBird® Pro	B							A		
PowerBird®, PowerBird® Solar iBird® Pro, PowerBird® Pro, PowerBird® Pro Gold Edition, PowerBird® Pro Gold Edition with spring-loaded trigger system	B	X	X	Y	Y					A

Tool	Energy	PolyGrip®				G-Bulb		MEGA GRIP® *	BULB-TITE® *	TRI-FOLD®	
		3.2	4.0	4.8	6.4	4.8	6.4			4.1	4.8
NTS, NTX, NTX-F, Flipper®, Flipper® Plus	H			A						A	A
HN2	H				SE with X		X	X	X		
HN2-BT	H										
SN2	H										
AccuBird®, AccuBird® Pro	B								X ¹		
PowerBird®	B				AS			6,4	X at 7,7		
PowerBird® Solar	B				AS			6,4	X at 7,7		
iBird® Pro, PowerBird® Pro	B				AS			6,4	X at 7,7		
PowerBird® Pro Gold Edition, PowerBird® Pro Gold Edition with spring-loaded trigger system	B							6,4	X at 7,7		

H: Handtool
B: Battery-powered tool

X: Special accessories required
X¹: At 6,3 AS
Y: Accessories included in the scope of delivery effectively expand the working range.

A: Alu/Copper
S: Steel
E: Stainless Steel / Monel
Blue box: All materials (ASE) can be riveted. Where there are exceptions, the letters of the rivetable materials are provided directly in the box.

*: A special nosepiece is **always** required when setting MEGA GRIP® blind rivets and BULB-TITE® blind rivets

Blind rivet hand tools

GESIPA® manual blind rivet setting tools - Easy to operate, tried and tested, always good but now even better!

GESIPA® has not only redesigned the classic NTX tools themselves but also optimised the surfaces and handles.

By utilising a soft rubber material, the new ergonomically designed handles make it easier to work while substantially relieving the strain on the hands.



NTX & NTX-F

Tried and tested technology and quality in a new design

2



Handles

- Ergonomically formed handles for working efficiently without fatigue
- Improved haptics by use of softer material
- Non-slip even in oily environments
- Environmentally compatible thanks to PVC-free handles
- Visually upgraded by GESIPA® logo and contrast stripes
- Optimised locking clip

Housing

- Improved performance thanks to newly designed housing
- Powder-coated abrasion-resistant housing surface in GESIPA® colour
- GESIPA NTX visually upgraded with Made in Germany lettering

Advantages

- Simple one-hand operation
- Effortless lever system
- Specially hardened GESIPA® jaw system
- Rugged design and durable
- Equipped with the most commonly used GESIPA® nosepieces secured directly on the tool
- Nosepieces quick and easy to change
- Worldwide service and spare parts available for decades to come
- Made in Germany



Blind rivet hand tools

NTS (with self opening spring)



Part no. 143 4028

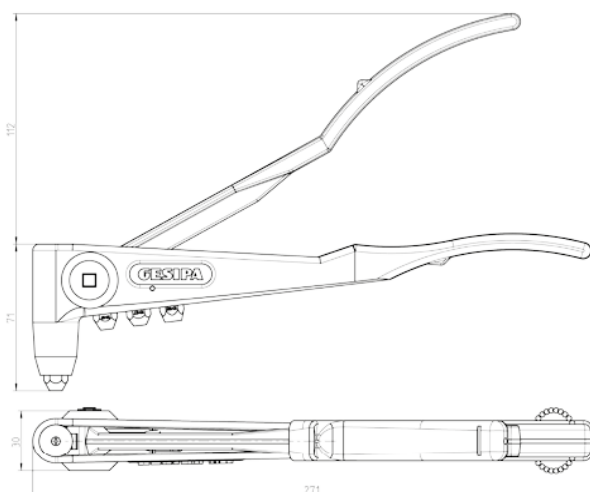

Dimensions in mm

Working range

Blind rivets up to 5 mm Ø aluminium and 4 mm Ø steel and stainless steel

Technical data

Weight: 480 g
Total length: 275 mm
Stroke: 8 mm

Accessories

Nosepieces: 10/18, 10/24, 10/27 and 10/32
1 maintenance wrench, operating instructions with spare parts list

Advantages

- Body casing in high-quality die cast aluminium
- Body head made of forged steel
- Narrow head for difficult to access rivet locations
- Opening spring for automatic ejection of the mandrel
- Ergonomic handles

Jaws (2-parts)

For NTS, NTX, NTX-F and Flipper®

Part no. 143 4071

Nosepiece assignment for NTS, NTX and NTX-F can be found on page 87.

Blind rivet hand tools

NTX & NTX-F

Working range

Blind rivets up to 5 mm Ø aluminium
and 4 mm Ø steel and stainless steel

Technical data

Weight:	575 g
Total length:	260 mm
Stroke:	8 mm

Advantages

- Body casing in high-quality die cast aluminium
- Body head made of chrome-vanadium steel, forged
- Steel inserts on all bearing points subject to wear
- Intermediate lever system reduces the force required and dampens the tear-off effect
- Narrow pliers head for difficult to access rivet locations
- Ergonomic slip handles
- Simple maintenance – fast jaw change

NTX



Part no. 143 4040

Accessories NTX

Nosepieces: 10/18, 10/24 and 10/32
1 maintenance wrench, operating instructions
with spare parts list

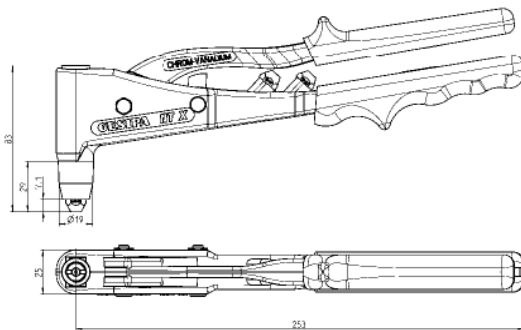

Dimensions in mm

NTX-F (with self opening spring)



Part no. 143 4042

Accessories NTX-F

Nosepieces: 10/24, 10/27 and 10/32
1 maintenance wrench, operating instructions
with spare parts list

Additional advantage NTX-F

- Opening spring for automatic ejection of the mandrel

Flipper®

The blind rivet hand tool for easy handling with only one hand.

Working range

Blind rivets up to 5 mm Ø aluminium and 4 mm Ø steel and stainless steel

Technical data

Weight:	750 g
Total length:	221 mm
Total stroke:	16.2 mm
Single action stroke:	1.8 mm

Nosepieces/accessories

Nosepieces: 10/18, 10/24 and 10/29
1 maintenance wrench (on magazine)
Operating instructions with spare parts list

Advantages

- The force increases when the handle is closed. This is made use of via the special arrangement of the lever when setting blind rivets: ergonomic design
- The required manual force is reduced by around 40 percent if actuated several times.
- Actuation lever with an opening spring for easy single-handed operation
- Jaw mechanism with spring reset for safe and automatic mandrel ejection
- Rivet mandrel collection container can be clipped to the body casing and is easy to empty
- Larger device lift: a benefit when handling extra long blind rivets
- Sturdy body casing in high-quality die cast aluminium
- Sturdy actuation lever made of tempered steel
- Link pin on anti-twist bearings
- Ergonomic lever positions and handle design



Part no. 143 3950

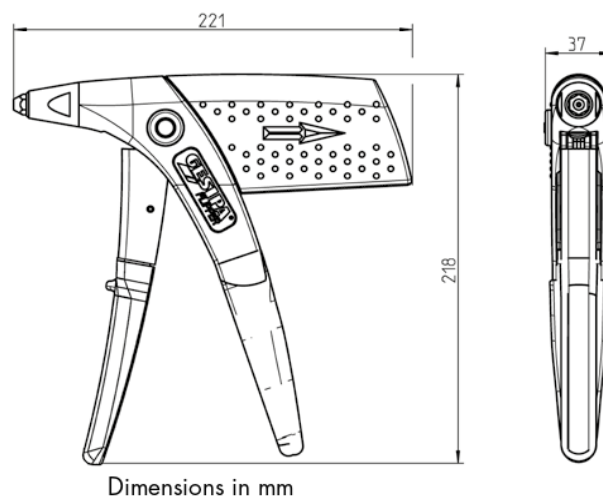

Conversion kit for plastic blind rivets:

Part no. 143 3984



Nosepiece assignment for Flipper® can be found on page 87.

Blind rivet hand tools – sortiment



Part no. 143 5457

Riveting kit

Contents

Blind rivet hand tool **NTX**
and **12 blind rivet sizes**,
1 maintenance wrench.
Weight: approx. 3.75 kg
Dimensions: 340 x 205 x 40 mm

Incl. 12 blind rivet sizes

Alu/steel	3.0 x 8.0 mm
Alu/steel	3.0 x 10.0 mm
Alu/steel	3.0 x 12.0 mm
Alu/steel	4.0 x 5.0 mm
Alu/steel	4.0 x 6.0 mm
Alu/steel	4.0 x 8.0 mm
Alu/steel	4.0 x 10.0 mm
Alu/steel	4.0 x 12.0 mm
Copper/steel	3.0 x 6.0 mm
Copper/steel	4.0 x 6.0 mm
Alu/steel	3.0 x 5.0 mm
Alu/steel	3.0 x 7.0 mm



Now also available as **Junior riveting kit PolyGrip® (Part no. 145 7662)** with the sizes 3.2 x 8, 4 x 10, 4 x 17, 4.8 x 10 and 4.8 x 17.

Junior riveting kit

Contents

Blind rivet hand tool **NTX**
and **5 blind rivet sizes**,
1 maintenance wrench.
Weight: approx. 2.5 kg
Dimensions:
275 x 145 x 40 mm

Incl. 5 blind rivet sizes

Alu/steel	3.0 x 6.0 mm
Alu/steel	3.0 x 8.0 mm
Alu/steel	4.0 x 6.0 mm
Alu/steel	4.0 x 10.0 mm
Steel/steel	3.0 x 6.0 mm

Junior riveting kit
Part no. 143 5459

Junior riveting kit PolyGrip®
Part no. 145 7662



Part no. 143 3951

Flipper® box

Contents

Blind rivet hand tool
Flipper® and **3 PolyGrip®**
blind rivet sizes, in a
lightweight plastic carrying case.
Weight: approx. 0.9 kg
Dimensions: 220 x 200 x 40 mm

Incl. 3 blind rivet sizes

PolyGrip® Alu/steel	3.2 x 8.0 mm
PolyGrip® Alu/steel	4.0 x 10.0 mm
PolyGrip® Alu/steel	4.8 x 10.0 mm

**Mini pack refills can be
found on page 292.**

Combi setting tool Flipper® Plus



Converted in under 1 minute in just a few simple steps

1. Removal

Remove the parts shown in the image



2. Installation

Install the threaded mandrel and nosepiece



3. Converted

Converted to a blind rivet nut setting tool



One setting tool – two functions

NEW

Virtually tool-free conversion from blind rivet to blind rivet nut setting tool

Working range blind rivets

Blind rivets up to 5 mm Ø aluminium and 4 mm Ø steel and stainless steel

Working range blind rivet nuts

Blind rivet nuts from M4 up to M6 aluminium as well as from M4 up to M5 steel

Technical data

Weight:	750 g
Total length:	217 mm
Total stroke:	16.2 mm
Single action stroke:	1.8 mm

Accessories

Nosepieces: 12/20, 12/24, 12/29, 12/M4, 12/M5 and 12/M6

Threaded mandrel conversion kit: M4, M5 and M6

1 maintenance wrench, 1 Allen key

1 jaw insertion aid

Operating instructions with spare parts list

Shared advantages

- New ratchet function
- The force increases when the handle is closed. This finding is put to good use in a special lever arrangement for setting blind rivets and blind rivet nuts: ergonomic design
- The required manual force is reduced by around 40 percent if actuated several times.
- Actuation lever with an opening spring for easy single-handed operation

Advantages when setting blind rivets

- Jaw mechanism with spring reset for safe and automatic mandrel ejection
- Rivet mandrel collection container can be clipped to the body casing and is easy to empty
- Larger device lift: a benefit when handling extra long blind rivets

Advantages when setting blind rivet nuts

- The total stroke is 16.2 millimeter long for setting of new generation multigrip blind rivet nuts like the GESIPA® PolyGrip® blind rivet nuts
- Simplified setting procedure for blind rivet nuts



Art.-Nr. 157 1258

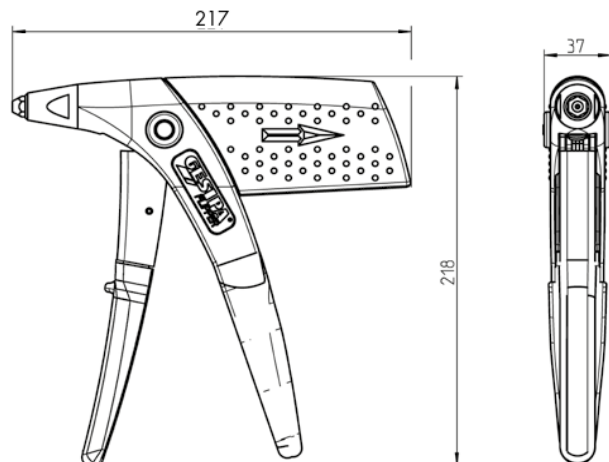

Dimensions in mm

Lever riveting tools

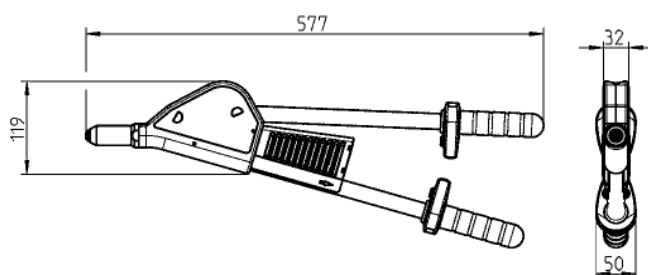

Dimensions in mm

HN 2

Part no. 143 4107

Working range

Blind rivets from 3.0 to 6.4 mm Ø all materials, except PolyGrip® blind rivets with 6.4 mm Ø made of stainless steel and G-Bulb blind rivets

Technical data

Weight:	1.85 kg
Total length:	570 mm
Stroke:	10 mm

Accessories

Nosepieces:
16/29, 16/32, 16/36, 16/40 and 16/45
Spent mandrel container
Maintenance instructions with spare parts list

Jaws (3 parts)

Part no. 143 4103

Advantages

- Pliers casing in high-quality die cast aluminium, its sturdy design protects it against soiling
- Link pin on anti-twist bearings and with inner axial protection, wear-proof and smooth running
- Tooth segment transmission with favourable lever arm arrangement reduces the force required and dampens the tear-off effect

HN 2-BT

Part no. 145 6714

(only for BULB-TITE® see page 70)

Working range

Blind rivets up to 7.7 mm Ø all materials

Technical data

Weight:	1.85 kg
Total length:	570 mm
Stroke:	10 mm

Accessories

Nosepieces:
16/26 BT, 16/32 BT, 16/42 BT and 16/48 BT
Spent mandrel container
Maintenance instructions with spare parts list

Jaws (3 parts): HN 2 BT

Part no. 143 4173

Nosepieces and performance see page 87.

- Fixed casing lever and ergonomic handle design: simple and easy handling
- Actuation lever: repeated re-engagement very easy, even on workpiece; highly beneficial for oversized blind rivets
- Gear rack: supported on a brass plate; smooth running
- Rivet mandrel collection tank: swivel-mounted to the casing; can be emptied easily and safely

Lazy tong riveting tool

SN 2



Part no. 145 6674

Jaws (3 parts)

Part no. 143 4958

Working range

Blind rivets from 3.0 up to 6.4 mm Ø all materials
G-Bulb blind rivets up to 4.8 mm Ø.

Technical data

Weight:	1.93 kg
Length when closed:	310 mm
Length when opened:	810 mm
Stroke:	10.5 mm

Accessories

Nosepieces for Ø 3.2 mm, 4.0 mm, 4.8 mm,
6.0 mm and 6.4 mm, 1 maintenance wrench,
Operating instructions with spare parts list

Advantages

- Pliers casing and handle in high-quality die cast aluminium
- Shear system in high strength steel, galvanised
- Moulded handle – double bearing
- Narrow casing for difficult to access rivets
- Enclosed pliers casing prevents soiling
- Favourable lever arm arrangement with 4-joint slide block bearing – reduced effort

Nosepiece assignment for manual, lazy tongue and lever rivet devices

Rivet Ø	Rivet material	NTS, NTX, NTX-F, Flipper®	SN2	HN2	HN2-BT
2,4	Alu	10/18	–	–	–
3.2	CAP®-Alu, CAP®-Cu	10/18	–	–	–
3 and 3.2	Alu, Cu, Steel, Stainless steel, Stinox, Alu, PG-Alu, PG-Steel	10/24	17/24	16/24	–
4	Alu, Cu	10/24	17/24	16/24	–
4	Steel, CAP®-Alu, CAP®-Cu, Alu, PG-Alu	10/27	17/27	16/27	–
4	Stainless steel, Stinox, PG-Steel	10/29	17/29	16/29	–
4.8	CAP®-Alu, CAP®-Cu	10/29	17/29	16/29	–
5 and 4.8	Alu, PG-Alu	10/32	17/29	16/29	–
5 and 4.8	Steel, Alu	–	17/32	16/32	–
5 and 4.8	Stainless steel, Stinox, PG-Steel	–	17/36	16/36	–
6	Alu	–	17/36	16/36	–
6	Steel	–	17/40	16/40	–
6.4	Alu, PG-Alu	–	17/40	16/40	–
6.4	Steel, Alu	–	17/45	16/45	–
4	all BULB-TITE®	–	–	–	16/26 BT
5.2	all BULB-TITE®	–	–	–	16/32 BT
6.3	all BULB-TITE®	–	–	–	16/42 BT
7.7	all BULB-TITE®	–	–	–	16/48 BT

Article numbers for nosepieces

Article	Part no.
10/18	143 4055
10/24	143 4061
10/27	143 4062
10/29	143 4064
10/32	143 4065
16/18	143 4285
16/24	143 4288
16/27	143 4289
16/29	143 4290
16/32	143 4291
16/36	143 4292
16/40	143 4293
16/45	143 4300
16/26 BT	143 4301
16/32 BT	143 4302
16/42 BT	143 4303
16/48 BT	143 4304

Nosepiece assignment data apply to DIN and GESIPA® blind rivets.

The Bird Pro series



The Bird Pro series

GESIPA®, which invented battery-powered blind riveting technology, has been producing the Bird series for over twenty years now. To this day, it sets the standard for the battery-powered blind riveting devices market. Not least due to changing customer requirements, the Bird family's modular system is updated on a regular basis. GESIPA® has therefore built a new platform that will supplement the current Bird series to meet the highest customer requirements. The new tools in this series are the **iBird® Pro, PowerBird® Pro Gold Edition, PowerBird® Pro, AccuBird® Pro, FireBird® Pro** and the **FireBird® Pro Gold Edition**.

Well-proven and ergonomically designed

The Bird Pro series is equipped with the low-wear jaws system and features the same ergonomic design as the TAURUS® series, already proven a thousand times over.



BLDC technology

A BLDC motor is a brushless DC motor that, instead of brushes that are susceptible to wear, uses electrical sensors to detect the rotor's position and commutate the stator coil via circuit breakers. A special software in the electronics controls the motor.

The advantages of a BLDC motor include high efficiency, long service life, particularly smooth running with a precision ball bearing and a reduction in electrical noise radiation.

Packaging

All tools in the Bird Pro series come in a practical plastic case.



Battery-powered blind rivet setting tools with brushless motor

Li-ion batteries

The GESIPA® Bird Pro series is equipped as standard with a new rechargeable 2.1 Ah li-ion slide-on battery. These rechargeable li-ion batteries feature the new Deep Sleep function. To keep intrinsic consumption as low as possible, after a set idle time, the battery automatically assumes "Deep Sleep" mode. The battery can then be woken directly in the tool. There is no delay after being woken and the battery is immediately ready for use.



Charging technology

The GESIPA® li-ion chargers are available for 110 V and 240 V AC voltages. The charger comes with a Euro plug as standard. Other versions for China, UK and USA are available on request.

Characteristics

1. Autoreverse function

Immediately after mandrel break-off, this optional operating mode stops the pulling process and moves the jaw assembly back into the initial position. This saves time and energy while making sure the tool is immediately ready for use.

2. Lighting

The light-emitting diodes precisely aligned to the work piece are integrated into the adjusting ring. There are three possible switch positions:

Process-controlled: The diodes remain illuminated after the setting process, which allows a continuous workflow even in bad lighting conditions.

Torch function :

Steady glow of diode (max.10 minutes)

Lighting off: saves electricity.

3. Sliding battery

New sliding battery with exact optical and acoustic charging status display prevents unpleasant surprises. The deep sleep function and the electrical feedback of the braking energy extend the battery range – a battery charge lasts for up to 2,000 riveting operations. Additional catching grids prevent falling.

4. Charging unit

Charging unit with quick-charge function. The battery can be used again after only 45 minutes of charging, and is fully charged after just 90 minutes.



Advantages

- More powerful and longer-lasting BLDC motor for quick flow of work
- 25 mm stroke for long blind rivets
- Up to 20 kN setting force for particularly large blind rivets
- Variable lighting in the adjusting ring
- Increased stability due to larger, non-slip stand surface and lower centre of gravity
- Easy-to-grasp housing thanks to Softgrip
- New sliding battery
- Charging unit with quick-charge function

iBird® Pro

NEW



Industry 4.0 with the iBird® Pro

Known as Industry 4.0, M2M or the Internet of Things, these concepts refer to intelligent and digitally networked systems in the production industry. The aim is to ensure that production is as self-organised as possible.

GESIPA® has developed the iBird® Pro with this in mind. The iBird® Pro is a networked battery-powered setting tool that can be connected to smartphones, tablets or a customer's IT infrastructure using WiFi or Bluetooth via a free GESIPA® app. This networking provides a number of additional benefits such as the monitoring of riveting processes, processing safety, status and service indicators, as well as quick and simple access to operating, maintenance and repair instructions – ultimately resulting in optimisation of the value chain.

The GESIPA® app

Using a QR code, the iBird® Pro can be connected to the GESIPA® app with ease. The app is available for smartphones, tablets and PCs (Android and iOS). The iBird® Pro can be connected to three devices at the same time.

The Andon ring

The iBird® Pro incorporates a signal ring for visualising riveting processes. The colours can be set individually via the app.



Advantages at a glance

NEW



Technical facts

- WiFi 2.4/5.0 GHz and Bluetooth (LE) wireless connection
- Tilt sensor can be connected via the app; during use, the tool is only enabled for the next riveting process once the tilting motion for ejecting the mandrel body has been performed
- Andon ring: Signal ring for visualising the riveting process, the colours can be set individually via the app

Premium software: optional setting process assistant*

- Setting process evaluation with fault detection, notification in app and via Andon ring (signal ring lights up based on the setting process evaluation and colour setting)
- Teaching mode for teaching in rivet configurations
- Creation of job lists to process various rivet configurations

Part no. 157 0451



Simple connection of the iBird® Pro with the GESIPA® app via QR code

For smartphone, tablet, PC (Android and iOS)

Premium software: setting process assistant

Connection with three smartphones, tablets or PCs at the same time (e.g. operator, foreman, process control centre)

What the iBird® Pro app offers:

- Various counters: Total, day, setting counter, countdown, OK*, NOK*.
- Fill level indicator, service indicator (spent mandrel container, cleaning or oiling jaws, full service)
- Optional setting process assistant*
- Monitoring of battery charge level, battery temperature and temperature of the tool control
- Maintenance instructions, maintenance history
- Error message, error history, acknowledgement history
- Tips and tricks
- Operating instructions

*Once paid premium software has been activated

iBird® Pro

NEW

iBird® Pro – the optional setting process assistant from GESIPA® provides assistance when evaluating riveting processes

iBird® Pro

With slide-on, rechargeable 18.0 V/2.1 Ah battery pack and charger in plastic carrying case

Part no. 156 7800

iBird® Pro

With two slide-on, rechargeable 18.0 V/2.1 Ah battery packs and charger* in plastic carrying

Part no. 156 7801

* Supplied with Euro plug as standard (other versions on request)

Powerful and fast

The iBird® Pro enhances the new Pro series. With a setting force of 15,000 N and the well-proven brushless motor, the iBird® Pro is powerful and fast when setting blind rivets up to Ø 6.4 mm in any material. The optional Autoreverse function additionally shortens the pulling process, ensuring the iBird® Pro is immediately ready for operation. The stroke has been substantially increased to 25 mm for the purpose of setting particularly long rivets.

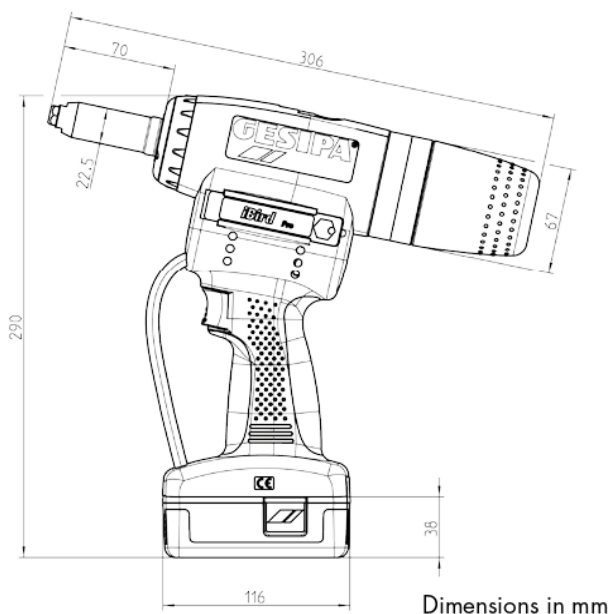

Even faster, virtually no wear

Since no wear-prone brushes are used, the motor of the iBird® Pro has an extremely long service life, is virtually non-wearing and reliably guarantees the fastest setting frequencies.

Well-proven and ergonomically designed

The iBird® Pro is equipped with the low-wear jaws system and features the same ergonomic design as the TAURUS® series, already proven a thousand times over.

The variable tool

Blind rivets from Ø 2.4* mm alu/steel, up to Ø 6.4 mm all materials, up to Ø 8 mm aluminium, except G-Bulb Ø 6.4 mm. BULB-TITE® blind rivets up to Ø 7.7 mm all materials. MEGA GRIP® blind rivets up to Ø 6.4 mm all materials.

***Make sure the correct jaw pusher is used as specified in the operating instructions!**

Technical data and accessories are the same as for the PowerBird® Pro and can be found on page 97.

The GESIPA® iBird® Pro app – simple connection and all information you need at a glance!

Connection

The iBird® Pro is extremely simple to connect thanks to the QR code located on your tool. Simply scan the QR code with the GESIPA® app (included in scope of delivery) and the iBird® Pro will automatically connect to your device.

It couldn't be simpler – no cabling and no modifications to menu settings in the device are needed.

Tool control

Now you have all the information you need at a glance! The GESIPA® iBird® Pro app displays the process status, counter reading and special events. How much longer will the battery last? When do I need to empty the spent mandrel container? How many rivets have been set per day? You can answer all these questions straight away by taking a look at the app.

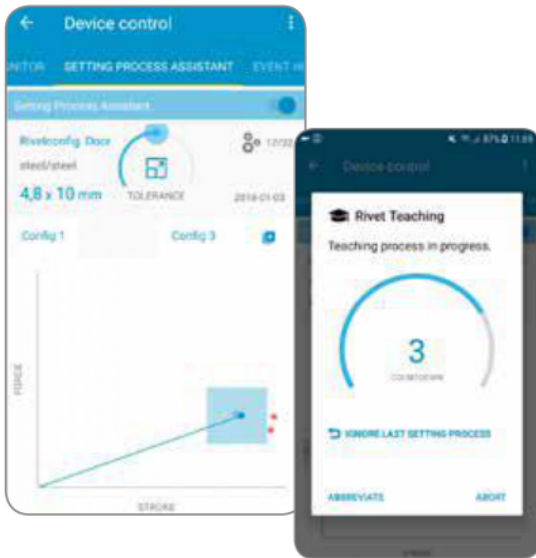

Operation and maintenance

Tips and tricks for handling the iBird® Pro or quick access to the operating instructions are available directly, with ease and at any location with the iBird® Pro app.

You have access to illustrated maintenance instructions at any time, and even error messages are displayed to you in the app.

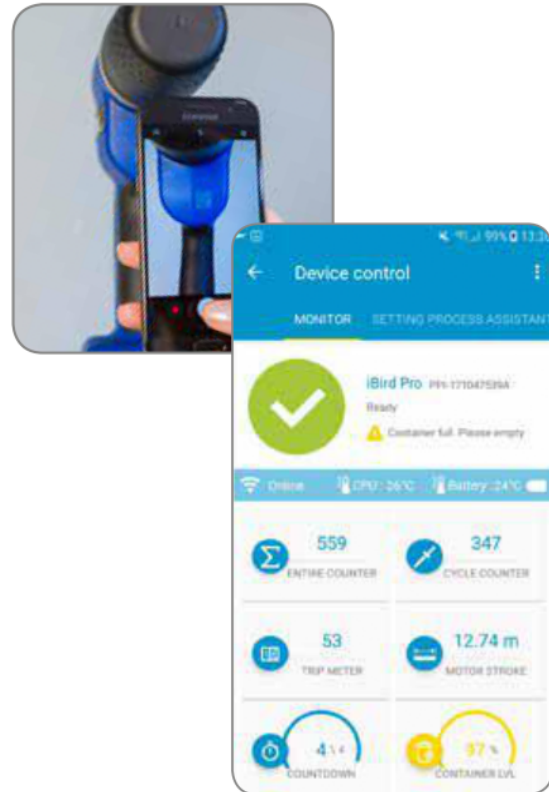

Setting process assistant

The optional setting process assistant from GESIPA® helps operators to adjust the setting process and evaluate riveting processes.

If a fault is detected, a message is issued in the app and the Andon ring lights up in colour.

Teaching mode – simple learning of rivet configurations and setting of the tolerance window by means of the virtual control dial.

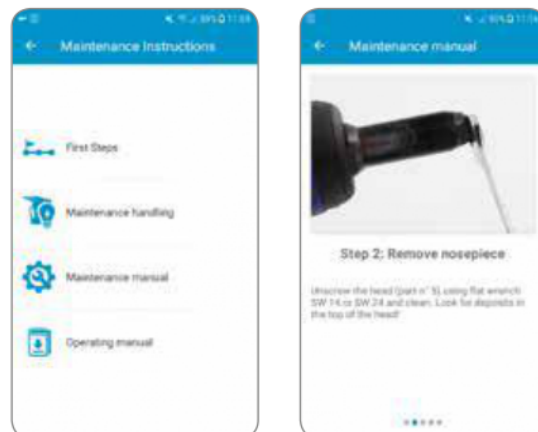

AccuBird® Pro

The latest generation of the battery-powered blind rivet setting tool – up to 4x faster than other battery-powered tools on the market!

AccuBird® Pro

With slide-on, rechargeable 18.0 V/2.1 Ah battery pack and charger in plastic carrying case

Part no. 143 5447

AccuBird® Pro

With two slide-on, rechargeable 18.0 V/2.1 Ah battery packs and charger* in plastic carrying case

Part no. 143 2365

* Supplied with Euro plug as standard (other versions on request)

AccuBird® Pro

The brushless motor and 10,000 N setting force make the AccuBird® Pro extremely fast for setting blind rivets of any material up to Ø 5 mm.

Extremely fast, virtually no wear

The BLDC motor of the AccuBird® Pro has an extremely long service life and is virtually non-wearing. Compared to commercially available battery-powered tools, setting can be done up to 4x faster making it comparable with hydropneumatic blind rivet setting tools.

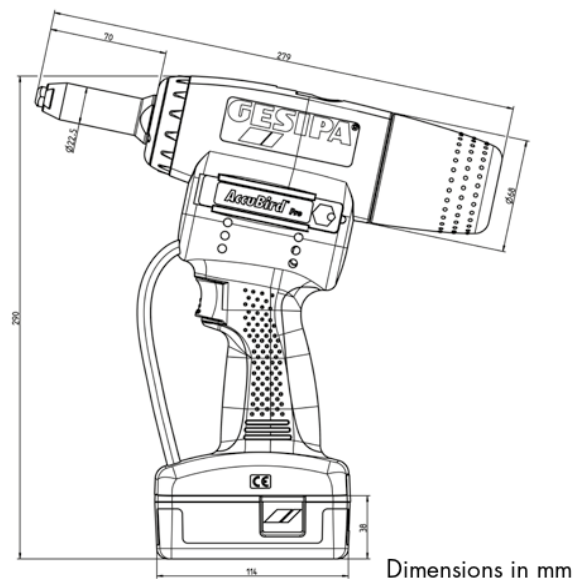

The optional Autoreverse function additionally shortens the pulling process, ensuring the AccuBird® Pro is immediately ready for operation.

Well-proven and ergonomically designed

The AccuBird® Pro is equipped with the low-wear jaws system and features the same ergonomic design as the TAURUS® series, already proven a thousand times over.

The variable tool

Blind rivets from Ø 2.4 mm aluminium, up to Ø 5 mm all materials and blind rivets up to Ø 6 mm aluminium. BULB-TITE® blind rivets up to Ø 4 mm and 5.2 mm aluminium and steel. G-Bulb blind rivets up to Ø 4.8 mm all materials.

Make sure the correct jaw pusher is used as specified in the operating instructions!

AccuBird® Pro – the battery-powered blind rivet setting tool with 10 kN setting force and brushless motor

Technical data

Setting force:	10,000 N
Weight:	2.0 kg with battery
Drive:	18 V brushless DC motor (BLDC)
Stroke:	25 mm

Equipment

Nosepieces: 17/24, 17/27, 17/29 and 17/32

18.0 V/2.1 Ah li-ion slide-on battery pack

Part no. 145 7641

Weight: 0.4 kg
available as special accessory



Charger for 18.0 V li-ion battery

Part no. 145 7642

Technical data

Input voltage:	100 - 240 V / 50 - 60 Hz
Output voltage:	21 V DC
Charging time:	45 to 90 minutes
Weight:	0.6 kg



Note: Equipped with Euro plug as standard (other versions on request)



Jaws (3-part)

Part no. 143 5568

Nosepiece assignment

Power per battery charge

Blind rivet Ø in mm	Material	approx. pc / battery charge	Nose-piece	Part no.
2.4	Alu	1,800	17/18*	143 4976
3.2	CAP®-Alu, CAP®-Cu	1,300	17/18*	143 4976
3 and 3.2	Alu	1,100	17/24	143 4955
3 and 3.2	Steel	1,100	17/24	143 4955
3 and 3.2	Stainless steel	1,100	17/24	143 4955
4	Alu	1,100	17/24	143 4955
4	Steel	1,000	17/27	143 4973
4	Stainless steel	950	17/29	143 4974
4.8 and 5	Alu	850	17/29	143 4974
4.8 and 5	Steel	750	17/32	143 4975
4.8 and 5	Stainless steel	550	17/36*	143 4977
6	Alu	400	17/36*	143 4977

Special accessory: Retaining nosepiece

- Inserted rivet remains in any position
- Rivets may be set with only one hand
- Safer working



Retaining nosepiece	Part no.	Retaining nosepiece	Part no.
17/18 R	143 5010	17/29 R	143 5013
17/24 R	143 5011	17/32 R*	143 5014
17/27 R	143 5012	17/36 R*	143 5015

*also for PowerBird®

BULB-TITE® blind rivet

Blind rivet Ø in mm	Material	approx. pc / battery charge	Nose-piece	Part no.
4	Alu	1,300	17/26 BT*	143 4985
5.2	Alu	1,100	17/32 BT*	143 4986
6.3	Alu	800	17/42 BT*	143 4988
6.3	Steel	550	17/42 BT*	143 4988

* available as special accessory
Special design nosepieces are available on request.
The nosepiece allocation data applies to DIN and GESIPA® blind rivets.

One-piece extension unit

for setting rivets in deep positions and with difficult access

One-piece, slim extension unit
approx. 106 mm

Part no. 145 0860

One-piece, slim extension unit
approx. 156 mm

Part no. 145 0861



Further extension units on page 102, 156 and 157.

PowerBird® Pro

PowerBird® Pro – the all-rounder in the Pro series. It combines exceptional speed with high power!

PowerBird® Pro

With slide-on, rechargeable 18.0 V/2.1 Ah battery pack and charger* in plastic carrying case

Part no. 145 0810

PowerBird® Pro

With two slide-on, rechargeable 18.0 V/2.1 Ah battery packs and charger* in plastic carrying case

Part no. 145 0814

* Supplied with Euro plug as standard (other versions on request)

Powerful and fast

The PowerBird® Pro enhances the new Pro series. With a setting force of 15,000 N and the well-proven brushless motor, the PowerBird® Pro is powerful and fast when setting blind rivets up to Ø 6.4 mm in any material. The optional Autoreverse function additionally shortens the pulling process, ensuring the PowerBird® Pro is immediately ready for operation. The stroke has been substantially increased to 25 mm for the purpose of setting particularly long rivets.

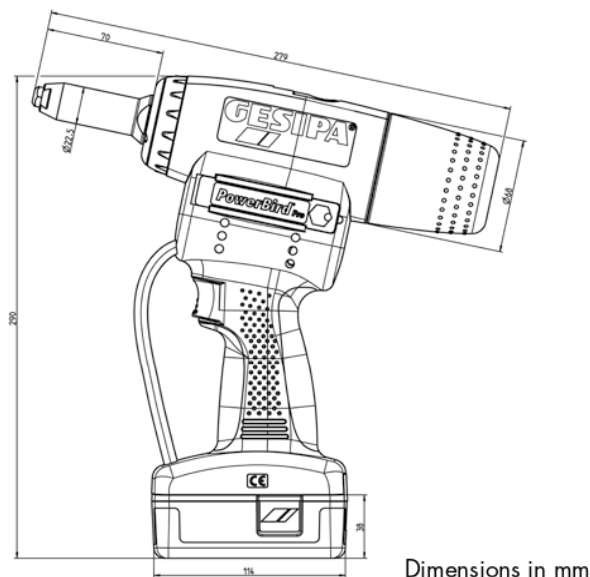

Dimensions in mm



Even faster, virtually no wear

Since no wear-prone brushes are used, the motor of the PowerBird® Pro has an extremely long service life, is virtually non-wearing and reliably guarantees the fastest setting frequencies.

Well-proven and ergonomically designed

The PowerBird® Pro is equipped with the low-wear jaws system and features the same ergonomic design as the TAU-RUS® series, already proven a thousand times over.

The variable tool

Blind rivets from Ø 4.8 mm steel, up to Ø 6.4 mm all materials, up to Ø 8 mm aluminium, except G-Bulb Ø 6.4 mm. BULB-TITE® blind rivets up to Ø 7.7 mm all materials. MEGA GRIP® blind rivets up to Ø 6.4 mm all materials.

Make sure the correct jaw pusher is used as specified in the operating instructions!

PowerBird® Pro – the battery-powered blind rivet setting tool with 15 kN setting force and brushless motor

Technical data

Setting force:	15,000 N
Weight:	2.2 kg with battery
Drive:	18 V brushless DC motor (BLDC)
Stroke:	25 mm

Equipment

Nosepieces: 17/32, 17/36, 17/40 and 17/45

18.0 V/2.1 Ah (li-ion) slide-on battery pack

Part no. 145 7641

Weight: 0.4 kg
available as special accessory



Jaws (3-part)

Part no. 143 5568

Nosepiece assignment

Blind rivet Ø in mm	Material	approx. pc / battery charge	Nose-piece	Part no.
4.8 and 5.0	Steel, Alu	1,000	17/32	143 4975
4.8 and 5.0	Stainless steel	700	17/36	143 4977
6.0	Alu	650	17/36	143 4977
6,0	Steel	500	17/40	143 4999
6.4	Alu, PG-Alu	550	17/45	143 4860
6.4	Steel	450	17/45	143 4860
8	Alu	500	17/45	143 4860

BULB-TITE® blind rivets*

4.0	Alu	1,200	17/26 BT*	143 4985
5.2	Alu	1,000	17/32 BT*	143 4986
6.3	Alu	800	17/42 BT*	143 4988
6.3	Steel	700	17/42 BT*	143 4988
6.3	Monel	650	17/42 BT*	143 4988
7.7	Alu	700	17/48 BT*	143 4989

MEGA GRIP® blind rivets*

4.8	Alu	800	17/31 MG*	143 4993
4.8	Steel	750	17/31 MG*	143 4993
4.8	Stainless steel	750	17/31 MG*	143 4993
6.4	Alu	700	17/41 MG*	143 4865
6.4	Steel	300	17/41 MG*	143 4865
6.4	Stainless steel	250	17/41 MG*	143 4865

* Available as special accessory

Special design nosepieces are available on request. The nosepiece allocation data applies to DIN and GESIPA® blind rivets.

Charger for 18.0 V li-ion battery

Part no. 145 7642

Technical data

Input voltage:	100 - 240 V / 50 - 60 Hz
Output voltage:	21 V DC
Charging time:	45 to 90 minutes
Weight:	0.6 kg



Note: Equipped with Euro plug as standard (other versions on request)



Special accessory: Retaining nosepiece

- Inserted rivet stays in any position
- Set rivets with only one hand
- Safer working



Retaining nosepiece	Part no.
17/32 R	143 5014
17/36 R	143 5015
17/40 R	145 7347
17/45 R	145 7348

One-piece extension unit

for setting rivets in deep positions and with difficult access

One-piece, slim extension unit
approx. 106 mm

Part no. 145 7650

One-piece, slim extension unit
approx. 156 mm

Part no. 145 7651



Further extension units on page 102, 156 and 157.

PowerBird® Pro Gold Edition

PowerBird® Pro Gold Edition – the strong one for high volumes and fast working sequences

PowerBird® Pro Gold Edition

With slide-on 18.0 V/2.1 Ah battery pack, charger* in plastic carrying case as well as additional jaw pusher for smaller blind rivet dimensions.

Part no. 145 7636

PowerBird® Pro Gold Edition

With two slide-on, rechargeable 18.0 V/2.1 Ah battery packs and charger* in plastic carrying case

Part no. 145 7640

* Supplied with Euro plug as standard (other versions on request)

Even more powerful

Thanks to the brushless motor and the 20,000 N setting force the PowerBird® Pro Gold Edition is even more powerful and can even set G-Bulb and Poly-Grip® blind rivets up to Ø 6.4 mm in any material. The optional Autoreverse function additionally shortens the pulling process, ensuring the PowerBird® Pro Gold Edition is immediately ready for operation.

The stroke has been substantially increased to 25 mm for the purpose of setting particularly long rivets.

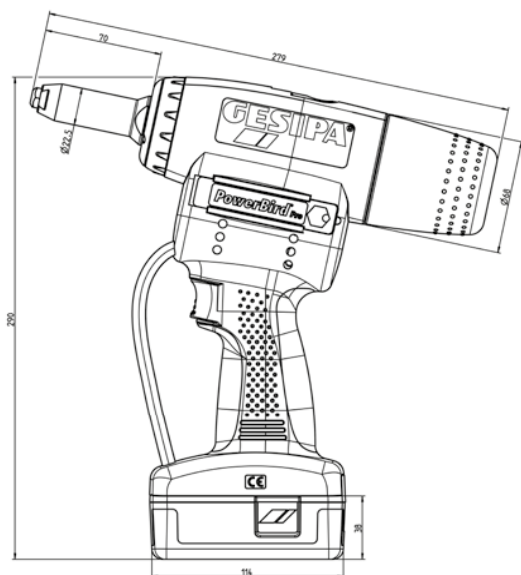

Dimensions in mm



Even faster, virtually no wear

Since no wear-prone brushes are used, the motor of the PowerBird® Pro Gold Edition has an extremely long service life, is virtually non-wearing and reliably guarantees the fastest setting frequencies.

Well-proven and ergonomically designed

The PowerBird® Pro Gold Edition is equipped with the low-wear jaws system and features the same ergonomic design as the TAURUS® series, already proven a thousand times over.

The variable tool

Blind rivets up to Ø 6.4 mm all materials and up to to Ø 8 mm aluminium. BULB-TITE® blind rivets up to Ø 7.7 mm all materials. MEGA GRIP® blind rivets up to Ø 6.4 mm all materials.

Make sure the correct jaw pusher is used as specified in the operating instructions!

PowerBird® Pro Gold Edition – the battery-powered blind rivet setting tool with 20 kN setting force and brushless motor

Technical data

Setting force:	20,000 N
Weight:	2.0 kg with battery
Drive:	18 V DC brushless DC motor (BLDC)
Stroke:	25 mm

Equipment

Nosepieces: 17/32, 17/36, 17/40 and 17/45

18.0 V/2.1 Ah (li-ion) slide-on battery pack

Part no. 145 7641

Weight: 0.4 kg
available as special accessory



Jaws (3-part)

Part no. 143 5568

Nosepiece assignment

Blind rivet Ø in mm	Material	approx. pc / battery charge	No-sepiece	Part no.
4.8 and 5.0	Steel, Alu	1,800	17/32	143 4975
4.8 and 5.0	Stainless steel	1,600	17/36	143 4977
6.0	Alu	1,000	17/36	143 4977
6.0	Steel	650	17/40	143 4999
6.4	Alu, PG-Alu	600	17/45	143 4860
6.4	Steel	550	17/45	143 4860
8	Alu	550	17/45	143 4860

BULB-TITE® blind rivets*

4.0	Alu	1,300	17/26 BT*	143 4985
5.2	Alu	1,200	17/32 BT*	143 4986
6.3	Alu	800	17/42 BT*	143 4988
6.3	Steel	550	17/42 BT*	143 4988
6.3	Monel	600	17/42 BT*	143 4988
7.7	Alu	700	17/48 BT*	143 4989

MEGA GRIP® blind rivets*

4.8	Alu	1,000	17/31 MG*	143 4993
4.8	Steel	950	17/31 MG*	143 4993
4.8	Stainless Steel	900	17/31 MG*	143 4993
6.4	Alu	950	17/41 MG*	143 4865
6.4	Steel	250	17/41 MG*	143 4865
6.4	Stainless Steel	250	17/41 MG*	143 4865

* Available as special accessory
Can be combined with accessories of other battery-powered blind rivet setting tools.
Special design nosepieces are available on request. The nose-piece allocation data applies to DIN and GESIPA® blind rivets.

Charger for 18.0 V li-ion battery

Part no. 145 7642

Technical data

Input voltage:	100 - 240 V / 50 - 60 Hz
Output voltage:	21 V DC
Charging time:	45 to 90 minutes
Weight:	0,6 kg



Note: Equipped with Euro plug as standard (other versions on request)

Special accessory: Retaining nosepiece

- Inserted rivet stays in any position
- Set rivets with only one hand
- Safer working



Retaining nosepiece	Part no.
17/32 R	143 5014
17/36 R	143 5015
17/40 R	145 7347
17/45 R	145 7348

One-piece extension unit

for setting rivets in deep positions and with difficult access

One-piece, slim extension unit
approx. 106 mm

Part no. 145 7650

One-piece, slim extension unit
approx. 156 mm

Part no. 145 7651

Further extension units on page 102, 156 and 157.



Bird Pro series with spring-loaded trigger system

The spring-loaded trigger system ensures that the parts to be riveted reliably make contact without any gaps before riveting. Furthermore, the operator will be certain that the blind rivet has reached its end position in the hole before setting and the setting head is in contact with the material. The pressing force can be varied with springs depending on the application.

Functional principle

The surface contact trigger mechanism is also installed on the trigger button of the device. It only allows the riveting device to trigger when a set compressive force on the part is reached. This ensures that the various components in the application are pressed correctly onto each other before the riveting process. This means that uncontrolled deformation of the rivet body between the materials is prevented, which would otherwise go undetected.

The surface contact force can be varied in five steps. It is set by either adding or removing springs. This rules out the possibility of unintentionally changing the defined surface contact force. A row of pushbuttons is arranged in front of the standard trigger button. On overcoming the spring force and reaching the defined surface contact force, the riveting process can only be triggered by pressing the yellow button.

The spring-loaded trigger system is only supplied completely mounted. Retrofitting is only possible through GESIPA®.

Dimensioned drawing of PowerBird® Pro Gold Edition with spring-loaded trigger system

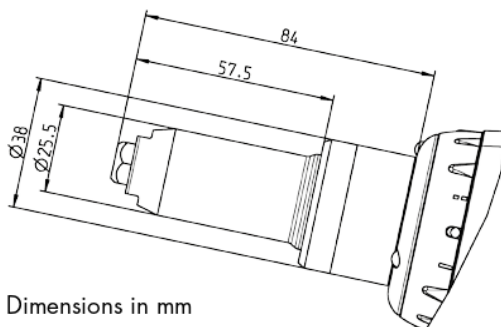

Dimensions in mm

The well-proven spring-loaded trigger system of the TAURUS® series now also for the Bird Pro series



Example image of PowerBird® Pro

The tools come with slide-on 18.0 V/2.1 Ah battery pack and charger in plastic carrying case

AccuBird® Pro with spring-loaded trigger system

Part no. 150 2102

PowerBird® Pro with spring-loaded trigger system

Part no. 150 2103

PowerBird® Pro Gold Edition with spring-loaded trigger system

Part no. 145 7638

Technical data:

See AccuBird Pro®, Page 94.

See PowerBird Pro®, Page 96.

See PowerBird Pro® Gold Edition, Page 98.

Angle head 90° for the Bird Pro series

The angle head 90° is designed for use in very narrow and confined spaces. The rugged design makes it possible to set blind rivets with a high setting force even in working areas that are difficult to access.

The angle head 90° can set standard blind rivets with a diameter up to 6.4 mm in all materials and 8 mm in aluminium with a setting force up to 20 kN. The smallest edge distance is 15 mm, the head length 110 mm.

The 17/45 WK nosepiece is included in the scope of delivery as standard. Nosepieces from 17/18 to 17/40 can also be used with the angle head 90°; however, this depends on the working range of the respective tool type (AccuBird® Pro, PowerBird® Pro or PowerBird® Pro Gold Edition).

Advantages

- Realisation of small edge clearances
- High setting force in tight installation areas
- Large stroke
- Simple assembly
- Compact and robust design
- Simple jaws maintenance
- Use of standard jaws

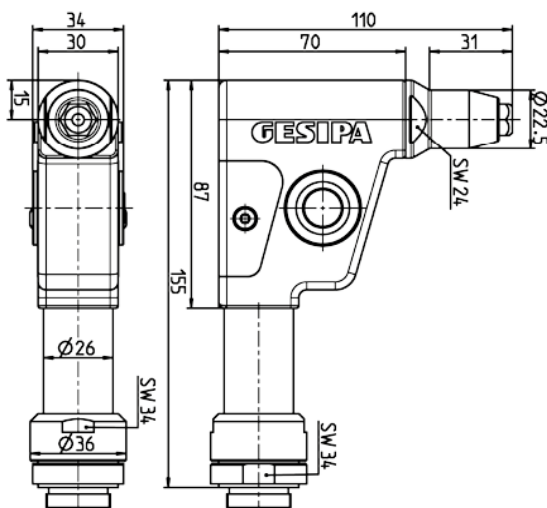

Dimensions in mm

The angle head can be positioned freely in every position (360°) on the tensile axis.



Part no. 146 4882

Technical data

Weight: 1.1 kg
Stroke: 23 mm
Traction power: up to 20 kN

Accessoires

Nosepiece: 17/45 WK (143 4948)

Jaws

Part no. 143 5568

Accessories for the Bird Pro series

Transparent spent mandrel container now also for the Bird Pro series



The classic spent mandrel container of the Bird Pro series is now also available in a transparent version which allows you to keep an eye on the amount of spent mandrels.

Part no. 145 0837

Extension for spent mandrel container Bird Pro series



**Extended by 30 mm:
Part no. 145 0838**

**Extended by 60 mm:
Part no. 145 0839**

Extension units



One-piece extension units replace the steel head sleeve, they are slim and are therefore particularly suitable for tight spaces that are difficult to access (Total length = steel head sleeve + standard nosepiece). **Multi-piece extension units** are suitable for riveting in low-lying places. They are screwed on between the tool and the existing steel head sleeve (total length = steel head sleeve + extension + standard nosepiece)

One-piece

The total length of the steel head sleeve is 35 mm each for 106 mm, 85 mm each for 156 mm and 135 mm each for 206 mm.

Tool	+35 mm	+85 mm	+135 mm
AccuBird® Pro	145 0860	145 0861	145 0862
PowerBird® Pro	145 7650	145 7651	145 0823
PowerBird® Pro Gold Edition	145 7650	145 7651	145 0823

Tool	+50 mm	+100 mm	+150 mm
PowerBird® Pro Gold Edition with spring-loaded trigger syst.	145 0821	145 0822	-

Multi-piece

Variable extension of the steel head sleeve is possible in steps of 100 mm. The total length of the steel head sleeve, including the extension unit, is 171 mm for 100 mm.

Tool	100 mm
AccuBird® Pro	145 0859
PowerBird® Pro	145 0820
PowerBird® Pro Gold Edition	145 0820

The Bird series

From the creator of the battery-powered blind rivet setting tool!



2

The Bird series

The development of this Bird series for professional use by specialists and industrial users made GESIPA® the inventor of the cable-free and hose-free blind rivet setting technology. In 2012 the first of the devices, the AccuBird®, celebrated its twentieth birthday.

Production

- Made in Germany
- GESIPA® development, market launch and further development since 1992 (AccuBird®), 1996 (PowerBird®), 1995 (FireBird®)
- 2014 Development and market launch of the new Bird Pro series

Modernised on its 25th anniversary

On the 25th anniversary of the AccuBird® the Bird series has been technically modernised and visually upgraded. The following modernisations have been implemented on the AccuBird®, PowerBird® and PowerBird® Solar:

- New battery management ensuring the longer-life battery is always ready
- Shorter pulling process with the new additional auto-reverse function. This reduces wear and increases the battery life.
- New lightweight and stable plastic case, same as the Pro series case.



The Bird series

Packaging

AccuBird®, PowerBird® and FireBird® are supplied in a plastic case .



Modernised on its 25th anniversary

- New battery management ensuring the longer-life battery is always ready
- Shorter pulling process with the new additional auto-reverse function. This reduces wear and increases the battery life.
- New lightweight and stable plastic case, same as the Pro-series case.

Casing and accessories

- Exchange for nosepieces and wrench for the AccuBird® and PowerBird® on the device, for the FireBird® in the spent mandrel container
- The spent mandrel container, has an approx. volume of 190 cm³, which means it does not need to be emptied frequently
- Accessories and special models have been continuously

With Li-Ion energy

- No memory effect
- High energy yield through high voltage and low weight for easy and fast operation
- Extremely low self discharge
- Battery shape allows the tool to be stored standing on its battery

Practical aspects

- Exchange nosepieces and wrench always included in the tool
- Compact, shockproof tool housing
- Spent mandrel evacuation into the mandrel container through backfilling and forwards through the nosepiece by gravity
- Fatigue-free working through well balanced weight repartition and ergonomic grip

Mechanics, control system and battery

- Reliable connection of the mechanics and control system
- Cast control system is water and dust-tight
- User-friendly pluggable rechargeable battery

Li-ion rechargeable batteries with new battery management

The GESIPA® AccuBird® and FireBird® battery-powered rivet setting tools are equipped as standard with a 1.3 Ah li-ion rechargeable battery. The GESIPA® PowerBird® variants come with a 2.6 Ah li-ion rechargeable battery. These li-ion batteries are equipped with a new battery management system that enables even longer battery life. The batteries are therefore always ready to use.

The powerful 2.6 Ah battery is also optionally available as a special accessory for the AccuBird® and FireBird®. Older tools can of course also be operated with the Li-Ion batteries. Due to the different charging principle used in the Li-Ion technology, the charging unit must also be replaced when switching over to Li-Ion batteries; the proven charging units for NiCd batteries are however still available.

Charging technology

A special, intelligent circuit in the GESIPA® Li-Ion batteries protects against deep discharging, and ensures that the last setting cycle can be completed, before the battery signals its empty condition by switching off. The empty battery is ready for use again after a charging time of only about one hour.

The new GESIPA® Li-Ion charging units are of course also available for the alternating voltages of 110 VAC and 230 VAC.



With new battery management always ready to use

AccuBird®

The well-proven blind rivet setting tools with Li-Ionen energy



AccuBird® with battery 14.4 V / 1.3 Ah and charger, in carrying case

Part no. 143 4898

AccuBird® with two batteries 14.4 V / 1.3 Ah and charger, in carrying case

Part no. 145 7235

AccuBird® – Production

- Developed and produced in Germany since 1992 by the inventor of the battery blind rivet setting tool

Reliability

- Electronic control
- No mechanical switching components
- Electronic temperature and overload protection
- High reliability through low loss power transmission via a highly efficient ball screw drive

Freedom

Cablefree tool for flexible operation in installation jobs and industry production

Auto-reverse function

Immediately after mandrel break-off, this additional operating mode stops the pulling process and moves the jaw assembly back into the initial position. This reduces wear, saves time and energy while making sure the tool is immediately ready for use.

High performance

- 10,000 N setting force
- High pulling force for safe setting of blind rivets up to 5 mm diameter in all materials
- High yield per battery charge
- Large 20 mm stroke

Versatility

Blind rivets from Ø 2.4 mm aluminium, up to Ø 5 mm all materials and blind rivets up to Ø 6 mm aluminium. BULB-TITE® blind rivets up to Ø 6.3 mm aluminium and steel.

High speed

- High speed of operation through automatic resetting of the jaw mechanism immediately after each setting process

With Li-Ion energy

- Choice of 1.3 Ah and 2.6 Ah Li-Ion batteries
- Even greater production rate per battery charge thanks to the new battery management system



AccuBird® – Rechargeable 14.4 volt riveting tool with Li-ion battery – Accessories

Working range

Blind rivets from Ø 2.4 mm aluminium, up to Ø 5 mm all materials and blind rivets up to Ø 6 mm aluminium. BULB-TITE® blind rivets up to Ø 6.3 mm aluminium and steel.

Nosepieces

17/24, 17/27, 17/29 and 17/32

Technical data

Weight: 2.0 kg with battery
 Stroke: 20 mm
 Drive: DC motor
 Traction power: 10,000 N

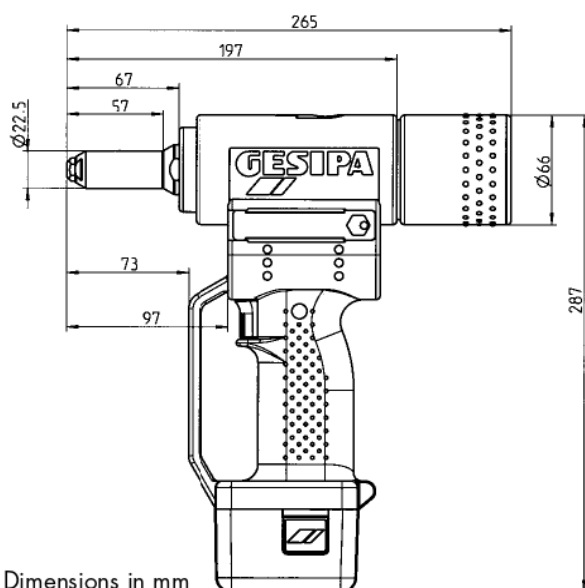

Dimensions in mm

AccuBird® with battery 14.4 V / 1.3 Ah and charger, in cardboard box

Part no. 145 7240

AccuBird® with battery 14.4 V / 1.3 Ah, in cardboard box

Part no. 145 7230

AccuBird® with battery 14.4 V / 1.3 Ah and charger with spring loaded trigger system in carrying case

Part no. 145 7232

Charger 14.4 V Li-Ion

Part no. 145 7282



Technical data

Input voltage: 230 V / 50 Hz
 Output voltage: 14.4 V DC
 Recharging time: 50 to 100 minutes (battery depending)
 Weight: 0.6 kg

Battery 14.4 V/1.3 Ah (Li-Ion)

Part no. 143 4921

Weight: 0.35 kg

Power battery 14.4 V/2.6 Ah (Li-Ion)

Part no. 145 7269

Weight: 0.5 kg
 available as special accessory

With new battery management always ready to use



AccuBird® – Rechargeable 14.4 volt riveting tool with Li-ion battery – Accessories

Nosepiece – power per battery charge

Rivet Ø in mm	Material	approx. pc/battery charge	Nose-piece	Part no.
2.4	Alu	1,500	17/18*	143 4976
3.2	CAP®-Alu, CAP®-Cu	1,000	17/18*	143 4976
3 and 3.2	Alu	800	17/24	143 4955
3 and 3.2	Steel	800	17/24	143 4955
3 and 3.2	Stainless steel	800	17/24	143 4955
4	Alu	800	17/24	143 4955
4	Steel	700	17/27	143 4973
4	Stainless steel	650	17/29	143 4974
4.8 and 5	Alu	550	17/29	143 4974
4.8 and 5	Steel	450	17/32	143 4975
4.8 and 5	Stainless steel	350	17/36*	143 4977
6	Alu	250	17/36*	143 4977

BULB-TITE® rivet

4	Alu	1,000	17/26 BT*	143 4985
5.2	Alu	800	17/32 BT*	143 4986
6.3	Alu	600	17/42 BT*	143 4988
6.3	Steel	300	17/42 BT*	143 4988

* available a special accessory
Special design nosepieces are available on request
Information about nosepiece allocations are valid for DIN compliant and GESIPA® blind rivets.

Special accessory: Retaining nosepiece

- Inserted rivet remains in any position
- Rivets may be set with only one hand
- Safer working



Retaining nosepiece	Part no.	Retaining nosepiece	Part no.
17/18 R	143 5010	17/29 R	143 5013
17/24 R	143 5011	17/32 R*	143 5014
17/27 R	143 5012	17/36 R*	143 5015

* also for PowerBird®

Universal nosepiece – 17

To suit AccuBird®

Part no. 143 4960



Detailed information can be found on page 155.

One-piece, slim extension unit

for setting rivets in deep positions and with difficult access

approx. 117 mm, Ø 22.5 mm

Part no. 145 7273



Part no. 145 7274

Detailed information can be found on page 115.

Extended spent mandrel container,

to suit AccuBird® and PowerBird®

Part no. 143 5034



Changeover set for BULB-TITE® blind rivets:

jaw pusher, jaws and 3 nosepieces

Part no. 143 5033

Jaws (3 parts)

Part no. 143 4958

PowerBird®

The well-proven blind rivet setting tool with Li-Ion energy and even higher setting performance

PowerBird® with power battery 14.4 Volt / 2.6 Ah and charger, in carrying case

Part no. 145 7186

PowerBird® with two power batteries 14.4 Volt / 2.6 Ah and charger, in carrying case

Part no. 145 7190

PowerBird® with power battery 14.4 Volt / 2.6 Ah and charger, in carrying case, with spring loaded-trigger system

Part no. 145 7207



PowerBird® Innovation

As the stronger brother to the well-known AccuBird® the PowerBird® is the powerful extension of the so-called „Bird family“ from GESIPA® able to cope with all structure blind rivets.

Practical aspects

User oriented scope of delivery: metal carrying case with one battery charger, one battery and four nosepieces

Economy

- Good price-performance ratio
- Large working range
- Short processing times
- High service life thanks to 2.6 Ah power battery

PowerBird® – With Li-Ion energy

2.6 Ah battery, alternatively 1.3 Ah on request

PowerBird® – The Versatility

Blind rivets from 4.8 mm Ø steel, up to 6.4 mm Ø all materials and up to 8 mm alu, except G-Bulb Ø 6.4 mm. BULB-TITE® blind rivets up to 7.7 mm Ø all materials. MEGA Grip® blind rivets up to 6.4 mm Ø all materials.



PowerBird® – Rechargeable 14.4 volt power battery riveting tool with Li-Ion battery for even higher performance

Working range

Blind rivets from Ø 4.8 mm steel, up to Ø 8 mm alu, up to 6.4 mm all materials, except G-Bulb Ø 6.4 mm. BULB-TITE® blind rivets up to Ø 7.7 mm, all materials. MEGA GRIP® blind rivets up to Ø 6.4 mm, all materials.

Technical data

Weight: 2.2 kg with battery
Stroke: 20 mm
Drive: DC motor
Traction power: 14,000 N

Nosepieces

17/32, 17/36, 17/40 and 17/45

Jaws (3 parts)

Part no. 143 4104

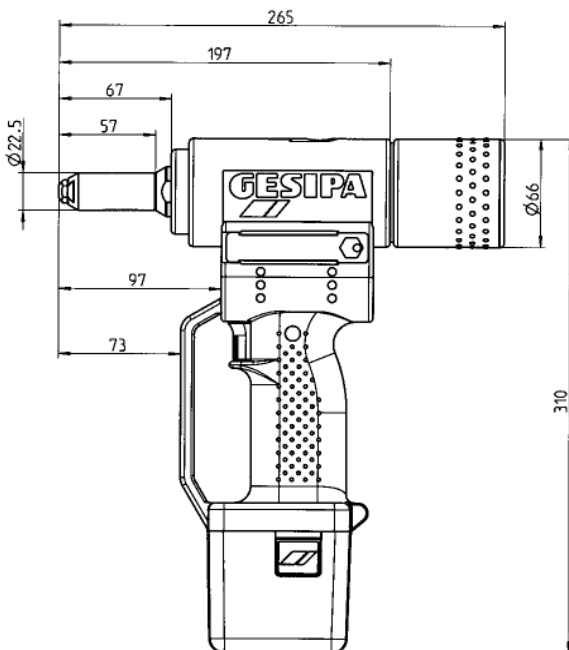

Dimensions in mm

Charger 14.4 V Li-Ion

Part no. 145 7282



Technical data

Input voltage: 230 V / 50 Hz
Output voltage: 14.4 V DC
Recharging time: 50 to 100 minutes (battery depending)
Weight: 0.6 kg

Battery 14.4 V/1.3 Ah (Li-Ion)

Part no. 143 4921

Weight: 0.35 kg
available as special accessory

Power battery 14.4 V/2.6 Ah (Li-Ion)

Part no. 145 7269

Weight: 0.5 kg

With new battery management always ready to use



PowerBird® – Rechargeable 14.4 volt power battery rive- ting tool with Li-Ion battery for even higher performance

One-piece, slim extension unit

for setting rivets in deep positions One-piece, slim extension unit to approx. 110 mm, Ø 22.5 mm, for setting rivets in deep positions and with difficult access

Part no. 145 7214

One-piece, slim extension unit to approx. 160 mm, Ø 22.5 mm, for setting rivets in deep positions and with difficult acces

Part no. 145 7215



Further dimensions available upon request

Extended spent mandrel container

to suit AccuBird® and PowerBird®

Part no. 143 5034



Special accessory: Retaining nosepiece

- Inserted rivet remains in any position
- Rivets may be set with only one hand
- Safer work



Retaining nosepiece	Part no.
17/32 R	143 5014
17/36 R	143 5015
17/40 R	145 7347
17/45 R	145 7348

Nosepieces – power per battery charge

Rivet Ø mm	Rivet material	approx. pc/bat- tery range	Nosepiece	Part no.
4.8 and 5.0	Alu	700	17/29	143 4974
4.8 and 5.0	Steel	700	17/32	143 4975
4.8 and 5.0	Stainless steel	600	17/36	143 4977
6.0	Alu	600	17/36	143 4977
6.0	Steel	300	17/40	143 4999
6.4	Alu, PG-Alu	450	17/45	143 4860
6.4	Steel	250	17/45	143 4860
8	Alu	350	17/45	143 4860

BULB-TITE® blind rivets

4.0	Alu	1,000	17/26 BT*	143 4985
5.2	Alu	900	17/32 BT*	143 4986
6.3	Alu	600	17/42 BT*	143 4988
6.3	Steel	350	17/42 BT*	143 4988
6.3	Monel	400	17/42 BT*	143 4988
7.7	Alu	500	17/48 BT*	143 4989
			and jaws	143 4173

MEGA GRIP® blind rivets

4.8	Alu	600	17/31 MG*	143 4993
6.4	Alu	450	17/41 MG*	143 4865
4.8	Steel	450	17/31 MG*	143 4993
6.4	Steel	150	17/41 MG*	143 4865
4.8	Stainless steel	450	17/31 MG*	143 4993
6.4	Stainless steel	150	17/41 MG*	143 4865

* available as special accessory

Special design nosepieces are available on request Information about nosepiece allocations are valid for DIN compliant and GESIPA® blind rivets.

PowerBird® Solar

Ideal for deep, difficult to access areas in solar applications

2

Part no. 145 7191

Working range

Blind rivets from Ø 4.8 mm steel up to 6.4 mm all materials, except G-Bulb Ø 6.4 mm.
 BULB-TITE® blind rivets up to Ø 7.7 mm, all materials.
 MEGA GRIP® blind rivets up to Ø 6.4 mm all materials.

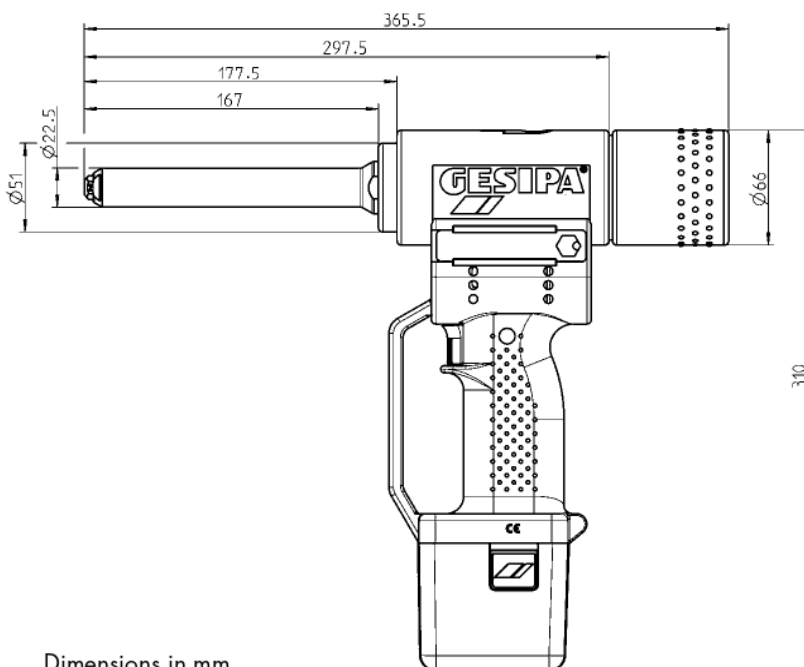

Dimensions in mm

Technical data

Weight:	2.42 kg with battery
Working stroke:	20 mm
Drive:	DC motor
Traction power:	14,000 N
Extension unit:	approx. 167 mm

Equipment

approx. 167 mm extension unit
 two Li-Ion power batteries 2.6 Ah/14.4 V
 Quick charger
 Nosepieces 17/32, 17/36,
 17/40, 17/45 and 17/48 BT
 Plastic carrying case

The GESIPA® SolarGrip® blind rivet program can be found on page 54.

PowerBird® and AccuBird® versions with spring-loaded trigger system

The well-proven spring-loaded trigger system of the TAURUS® series now as well for AccuBird® and PowerBird®

This feature ensures that the materials of the riveting application will be pressed together before the rivet is installed, thus avoiding gaps in between. Moreover the operator will be certain that the rivet has reached its end position in the application and that the setting head is in contact with the upper side of the material. The pressing force can be adjusted variably with springs depending on the application.

Process-secure blind riveting even of parts with gaps or recoiling elements

The function

The surface contact trigger mechanism is also installed on the trigger button of the device. It only allows the rivet device to be triggered if a settable compressive force on the part is reached. This ensures that the various components of the application are pressed correctly onto each other before the riveting process. In turn, this means that the uncontrolled deformation of the rivet body between the materials is prevented, which would otherwise go undetected.

The surface contact force may vary in five steps. It is set by either adding or removing springs. This rules out the possibility of unintentionally adjusting the defined surface contact force. Push buttons are arranged in series in front of the standard trigger button. The rivet process can only be triggered by pressing the yellow trigger button when the spring force has been overcome and the defined surface contact force has been reached.

Ensuring correct processing of the blind rivets by means of a defined contact pressure

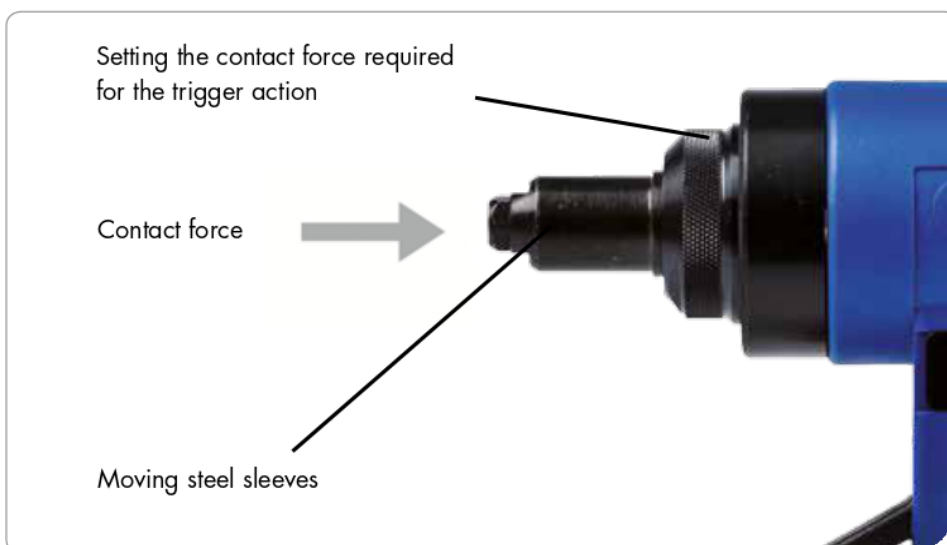

PowerBird® and AccuBird® versions with spring-loaded trigger system

AccuBird® with spring-loaded trigger system

with battery 14.4 V / 1.3 Ah and charger, in metal carrying case, Nosepieces 17/24, 17/27, 17/29 and 17/32

Part no. 145 7232

The spring-loaded trigger system is only supplied completely mounted. It can only be retrofitted by GESIPA®.

PowerBird® with spring-loaded trigger system

with power battery 14.4 Volt / 2.6 Ah and charger, in metal carrying case, Nosepieces 17/32, 17/36, 17/40 and 17/45

Part no. 145 7207



PowerBird® Solar with spring-loaded trigger system

with power battery 14.4 Volt / 2.6 Ah and charger, in plastic carrying case, Nosepieces 17/32, 17/36, 17/40 and 17/45 approx. 160 mm extension unit

Part no. 146 4037



PowerBird® dimension drawing with spring-loaded trigger system

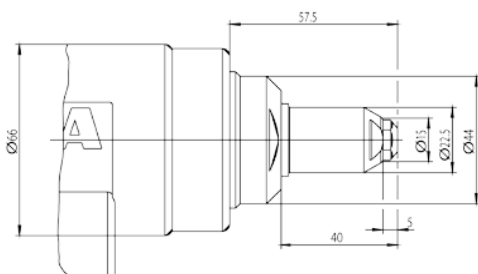

Dimensions in mm

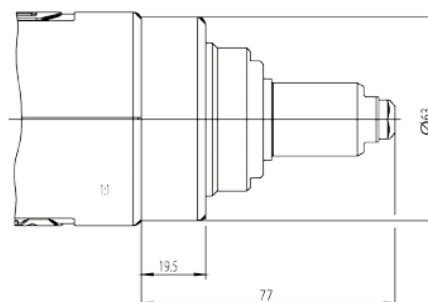

Angle head 90° compact for PowerBird® and AccuBird®

Can be swivelled 360° on the AccuBird® and PowerBird® tensile axis

Part no. 145 7252



Description

Using the angle head 90° compact for PowerBird® and AccuBird® allows to set all Types of standard blind rivets up to 5 mm in diameter and aluminium up to 6 mm diameter, depending on the tool Type. The minimum edge clearance is 12 mm, the head length is 90 mm. The angle head can be freely fixed in any position around the AccuBird® and PowerBird® tensile axis (360° free rotation).

Application

The angle head 90° compact is designed for use in tight spaces. Its sturdy design allows it to apply large setting forces when setting blind rivets even in difficult of access work areas with up to 10 kN.

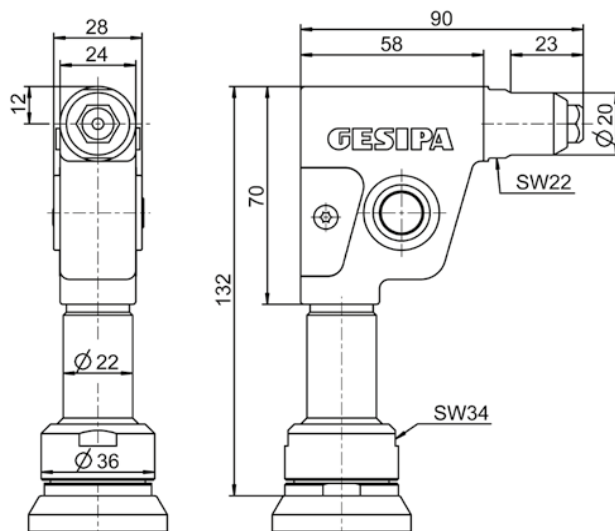

Dimensions in mm

Technical data

Weight: 0.7 kg
Stroke: 20 mm
Traction power: up to 10 kN

Accessoires

Nosepieces: 16/36

Advantages

- Realisation of small edge clearances (12 mm)
- High setting force in tight installation areas (up to 10 kN)
- Large stroke (up to 20 mm)
- Simple assembly
- Compact and robust design
- Simple jaws maintenance
- Use of standard jaws
- Low vibration, even at high breaking force level



Extension units for PowerBird® and AccuBird®



One-piece extension units

For setting rivets in deep positions and with difficult access.

Total length = steel head sleeve + standard nosepiece

Multi-piece extension units

For setting rivets in deep positions. They are screwed on between the tool and the existing steel head sleeve.

Total length = steel head sleeve + extension + standard nosepiece

One-piece

The total length of the steel head sleeve is 117 mm each for 50 mm, 167 mm each for 100 mm and 217 mm each for 150 mm.

Tool	50 mm	100 mm	150 mm
AccuBird®	145 7273	145 7274	145 0622
PowerBird®	145 7214	145 7215	146 4038
PowerBird® with spring-loaded trigger system	145 7222	145 7224	-

Multi-piece

Variable extension of the steel head sleeve is possible in steps of 100 mm. The total length of the steel head sleeve, including the extension unit, is 167 mm for 100 mm.

Tool	100 mm
AccuBird®	145 7318
PowerBird®	145 7229

Pneumatic blind rivet setting tools

Hydro-pneumatic blind rivet setting tools



118



124

TAURUS® 1-6



128

Protective sleeve



134

TAURUS® 1-4 with counter device



135

TAURUS® 1-4 with counter device eco



136

TAURUS® 4 CF



137

TAUREX 1- 6



140

TAURUS® 1-4 Axial eco
TAURUS® 1-4 Axial

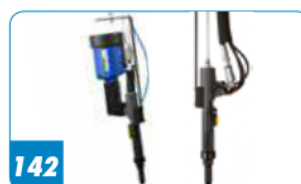

142

TAUREX 1-4 Axial compact
TAUREX 1-4 Axial



146

TAURUS® 1-4 C AV

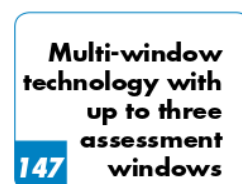

147

TAURUS® WinTech



148

PH 1



149

PH 2



150

PH 2000



151

PH 2-VK



152

PH Axial



162

GAV 8000



170

GAV HF

What rivets what?

	Energy	Ø mm												
		2.4	3.0	3.2	4.0	4.8	5.0	6.0	6.4	8.0	10.0			
PH1	P	X												
PH2	P	X							AS					
PH2 VK	P				AS									
PH Axial	P	X	X	X				AS						
PH 2000	P	X	X	X										
TAURUS® 1, TAUREX 1	P				AS									
TAURUS® 2, TAUREX 2	P								A					
TAURUS® 3, TAUREX 3	P													
TAURUS® 4, TAUREX 4	P											A		
TAURUS® 5-6, TAUREX 5-6	P													

	P	PolyGrip®				G-Bulb		MEGA GRIP®	BULB-TITE®	TRI-FOLD®	
		3.2	4.0	4.8	6.4	4.8	6.4	*	*	4.1	4.8
PH1	P										
PH2	P										
PH2 VK	P		AS								
PH Axial	P										
PH 2000	P										
PH 2000 BT	P										
TAURUS® 1, TAUREX 1	P		A								
TAURUS® 2, TAUREX 2	P										
TAURUS® 3, TAUREX 3	P				AS		S				
TAURUS® 4-6, TAUREX 4-6	P										

P: Hydro-pneumatic tool

X: Special accessoires required

A: Alu/Copper

S: Steel

E: Stainless Steel / Monel

Blue box: All materials(ASE) can be riveted. Where there are exceptions, the letters of the rivetable materials are provided directly in the box.

*: A special nosepiece is **always** required when setting MEGA GRIP® blind rivets and BULB-TITE® blind rivets.

The TAURUS® series

Pneumatic-hydraulic blind rivet setting tools made by GESIPA® are ideal in dealing with almost any Type of application. The cost-efficient construction, perfect handling properties and practical accessories are what make the TAURUS® series so unique and flexible.



Advantages which simply cannot fail to convince you!

Since the market introduction of the TAURUS® 2 in the year 2002, the TAURUS® series has managed to convince thousand times over in trade and industry. The TAURUS® 2 especially is a true all-rounder.

TAURUS 

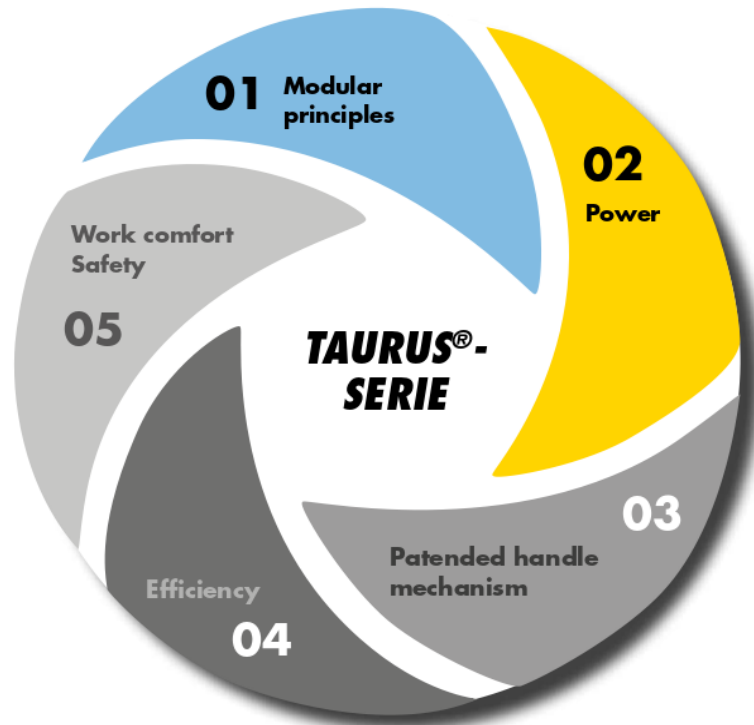

01 Modular principles

- Widest possible parts commonality – low spare part stocks required and simple maintenance
- Flexible adaption to new applications

02 Power

- High setting forces combined with low weight
- Fast work cycle
- Optimised stroke for the entire series

03 Patented handle mechanism

- With forcibly actuated jaws by pneumatic pressing
- Safe, non-slip gripping of the rivet mandrel
- Just one model of jaws for all tools
- Very long service lives

04 Efficiency

- Little compressed air consumption thanks to dual function: setting the rivets and extracting the spent mandrels use the same air
- Air suction needed only for vertical downwards riveting. Can be permanently switched-off if not needed.

05 Work comfort / safety

- Rubberised, moulded grip
- Balanced center of gravity
- Low-vibration and soandproofed
- Little activation force required
- Spent mandrel container with swivelling air deflector
- Overpressure valve for prevention of overload
- Integrated protection feature prevents the ejection of spent mandrels while the spent mandrel container is removed

TAURUS® series – Unique in the market!

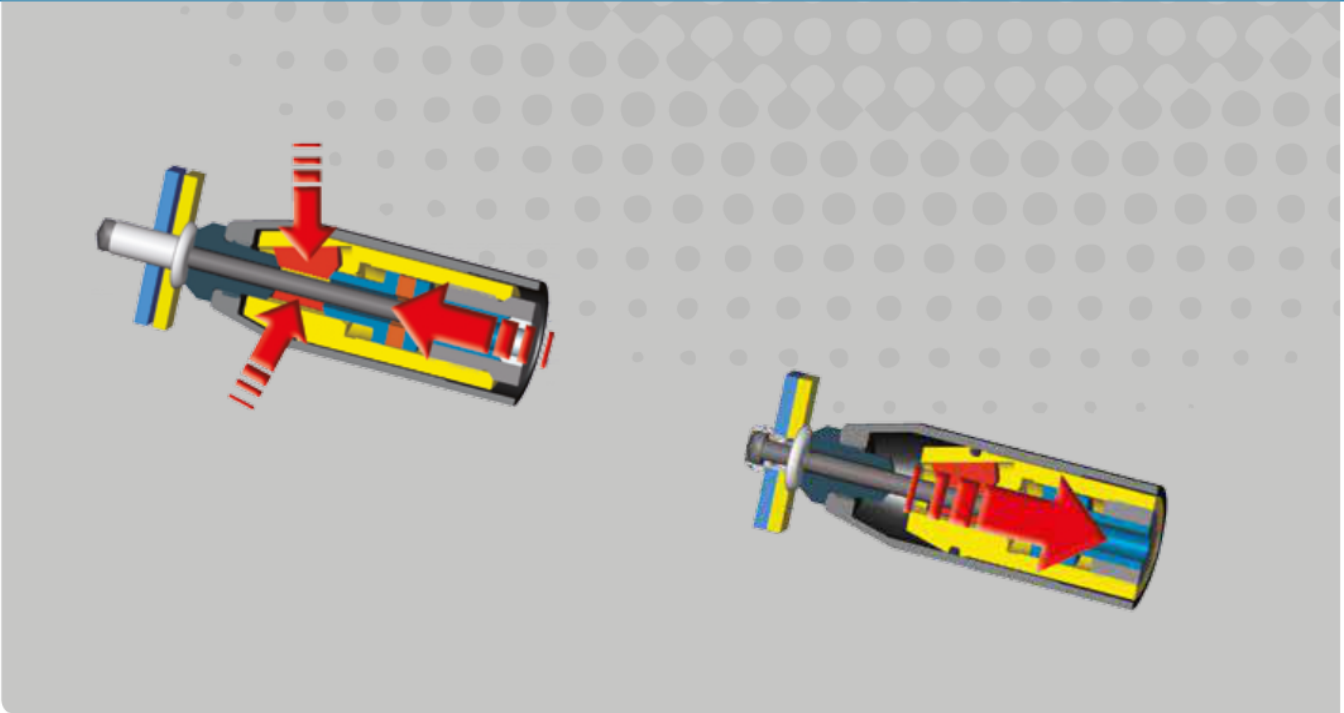

The TAURUS® tool series is equipped with a high-performance, patented grip mechanism and jaw system

Patented jaw system

- > The three jaws move in separate channels while being under forced control.
- > The jaws are pressed onto the mandrel by using compressed air instead of spring force – the force being ten times higher than usual.
- > Due to the high pressure the jaws immediately cling to the mandrels upon triggering the riveting process, only then the pulling movement starts.

GESIPA®-system – decisive advantages

- > The complete stroke of the tool is used for setting the rivet guaranteeing a reliable setting process.
- > The immediate and non-slip grip of the mandrel reduces abrasion and troublesome soiling.
- > Since the jaws do not slide along the mandrel, the wear and tear of the jaw profiles is reduced.
- > **Lower costs due to longer service life and low requirements regarding maintenance and spare parts needed.**

TAURUS® series – Maximum Efficiency!



The GESIPA® System – Optimum use of compressed air ensures maximum efficiency and low operating costs.

Compressed air is used very often in industrial production because of its flexibility. It does, however, cause relatively high costs and its consumption damages the environment. These disadvantages are more than enough reason for GESIPA® to equip the TAURUS® tool series with a special technique that allows to save compressed air and is unique throughout the world.

The GESIPA® System uses the compressed air required for the setting process twice. First, to set the blind rivet and secondly, to extract the spent mandrel. Dual use of the compressed air means no expensive, fresh compressed air is needed which other tools on the market constantly need just to extract the spent mandrel. And, last but not least, noise emission from the TAURUS®-tools is extremely low.

In two-shift operation and with compressed air costs of approximately € 0.03 per m³ this innovative technique allows savings of up to € 720 per year and tool. A TAURUS® 2 can pay for itself in less than one year.

TAURUS® device series – The modular concept

The TAURUS® series –
unique modular principle.
Minimal spare parts
stocks, easy maintenance

Extension units



Single-piece
(different sizes)



Multi-piece
(different sizes)

Nosepieces different sizes



Hanger

Spring-loaded trigger system



External trigger system



Air suction function

Nosepiece allocation



GESIPA®-Interface

Setting process monitoring



TAURUS® device series – The modular concept

Versatile accessories complete the range!

The modular concept for the TAURUS® series 1-4 lets the user customise the TAURUS® devices to match his individual requirements. Many identical parts that can be used across all devices reduce the need to stock spare parts and make maintenance easy.

This wide range of options provides the user with a high degree of flexibility. Each device in the TAURUS® series 1-4 can be fitted with many different spare parts or refitted according to the application.

Tool mount



Rivet mandrel evacuation hose



Blind rivet counters



Spent mandrel container adaptable for TAURUS® tools 1-4



Counter eco



Swivel air connector



Flexible base

Optimized stability



TAURUS® series



with silencer

TAURUS® 1

Part no. 145 7665

Working range

Sets blind rivets from 2.4 up to 3.2 mm Ø all materials and up to 4 mm Ø alu/steel (max. mandrel Ø 2.5 mm)

Technical data

Weight: 1.3 kg
 Operating air pressure: 5-7 bar
 Air hose connection: 6 mm Ø (1/4")
 Air consumption: approx. 1.0 ltr. per rivet
 Traction power: 5,500 N at 6 bar
 Stroke: 15 mm

Equipment

Nosepieces: 17/18, 17/20 and 17/22, maintenance wrench SW12/14, SW14/17, 1 hydraulic oil bottle 100 ml, 1 oil refill can, Operating instructions with spare parts list

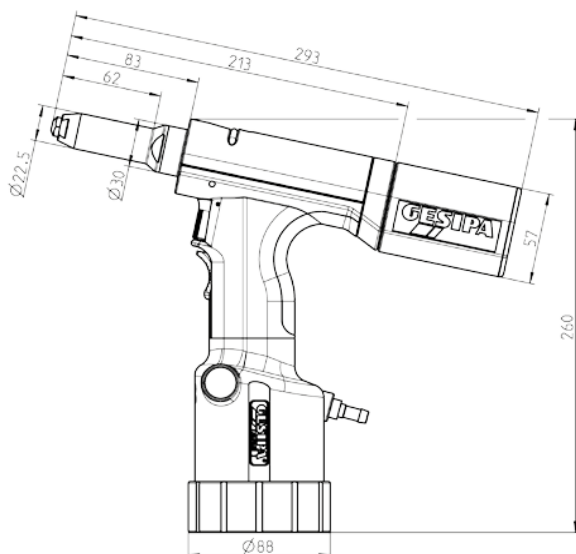

Dimensions in mm



TAURUS® 2

Part no. 145 7771

Working range

Sets blind rivets up to 5 mm Ø all materials and up to 6 mm Ø alu/steel (max. mandrel Ø 3.2 mm)

Technical data

Weight: 1.6 kg
 Operating air pressure: 5-7 bar
 Air hose connection: 6 mm Ø (1/4")
 Air consumption: approx. 2.3 ltr. per rivet
 Traction power: 11,000 N at 6 bar
 Stroke: 18 mm

Equipment

Nosepieces: 17/24, 17/27, 17/29 and 17/32, maintenance wrench SW12/14, SW14/17, 1 hydraulic oil bottle 100 ml, 1 oil refill can, Operating instructions with spare parts list

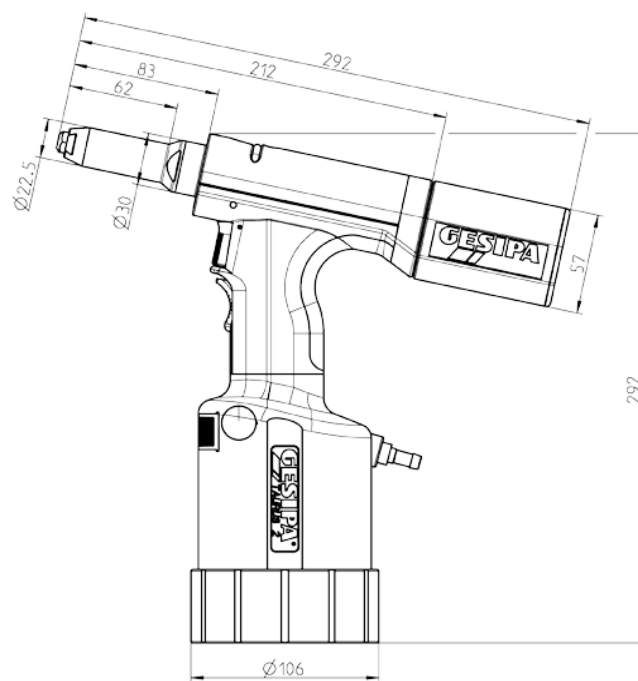

Dimensions in mm

Pneumatic-hydraulic blind rivet setting tools



TAURUS® 3

Part no. 145 7871

Working range

Sets blind rivets up to 6.4 mm Ø all materials (max. mandrel Ø 4.5 mm)

Technical data

Weight: 1.9 kg
 Operating air pressure: 5-7 bar
 Air hose connection: 6 mm Ø (1/4")
 Air consumption: approx. 4.8 ltr. per rivet
 Traction power: 18,000 N at 6 bar
 Stroke: 25 mm

Equipment

Nosepieces: 17/36, 17/40 and 17/45, maintenance wrench SW12/14, SW14/17, 1 hydraulic oil bottle 100 ml, 1 oil refill can, Operating instructions with spare parts list

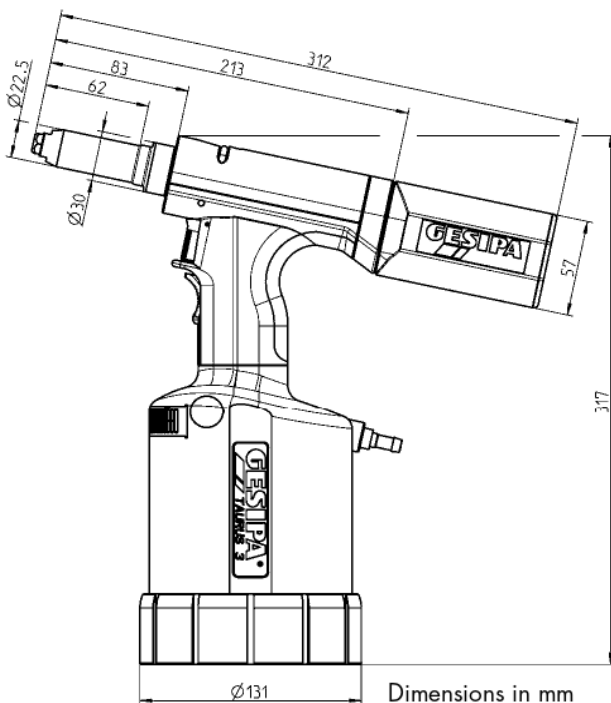

TAURUS® 4

Part no. 145 7964

Working range

Sets blind rivets up to 6.4 mm Ø all materials and up to 8 mm Ø alu (max. mandrel Ø 4.5 mm)

Technical data

Weight: 2.0 kg
 Operating air pressure: 5-7 bar
 Air hose connection: 6 mm Ø (1/4")
 Air consumption: approx. 4.8 ltr. per rivet
 Traction power: 23,000 N at 6 bar
 Stroke: 19 mm

Equipment

Nosepieces: 17/36, 17/40 and 17/45, maintenance wrench SW12/14, SW14/17, 1 hydraulic oil bottle 100 ml, 1 oil refill can, Operating instructions with spare parts list

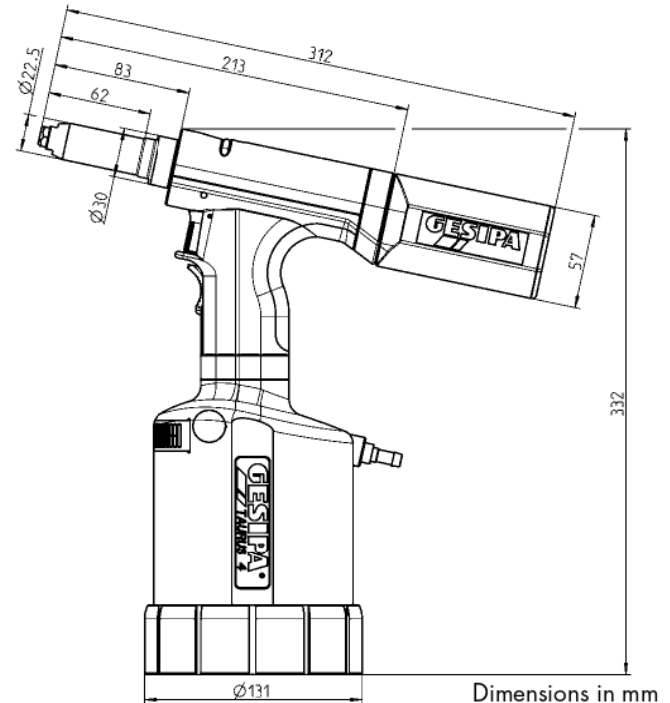

TAURUS® series



TAURUS® 5

Basic tool
Part no. 145 8002

Working range

Blind rivets above 6.4 mm Ø all materials and lockbolts up to 10 mm Ø with corresponding pulling heads (look on page 138).

Technical data

Weight:	3.4 kg
Operating air pressure:	5-7 bar
Air hose connection:	6 mm Ø (1/4")
Air consumption:	approx. 6.9 ltr. per rivet
Traction power:	42,000 N at 7 bar
Stroke:	17 mm

Equipment

- 1 hydraulic oil bottle 100 ml
- 1 oil refill can
- Operating instructions with spare parts list

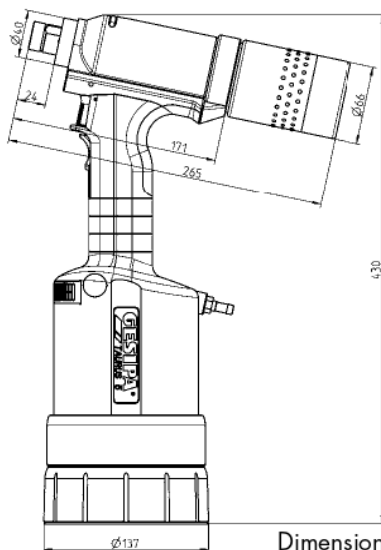

TAURUS® 5 and 6 need to be fitted with nosepieces to match the application. Will be produced on request.

Dimensions in mm



TAURUS® 6

Basic tool
Part no. 145 8022

Working range

Blind rivets above 6.4 mm Ø all materials and lockbolts up to 10 mm Ø with corresponding pulling heads (look on page 138).

Technical data

Weight:	3.4 kg
Operating air pressure:	5-7 bar
Air hose connection:	6 mm Ø (1/4")
Air consumption:	approx. 6.9 ltr. per rivet
Traction power:	50,000 N at 7 bar
Stroke:	15 mm

Equipment

- 1 hydraulic oil bottle 100 ml
- 1 oil refill can
- Operating instructions with spare parts list

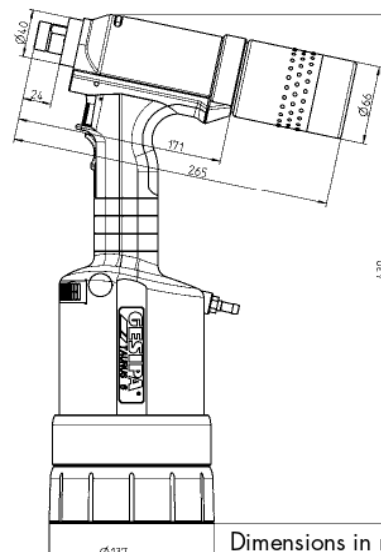

TAURUS® 5 and 6 need to be fitted with nosepieces to match the application. Will be produced on request.

Dimensions in mm

Accessories – TAURUS® series 1-4

The comprehensive range of accessories allows you to adapt your tool to virtually any challenge – whether trade, construction or industrial applications.

Nosepieces



For long mandrels, special blind rivets and other challenges

The use of the correct nosepiece is essential for ensuring reliable riveting and a neat riveted joint. A large selection of standard and special nosepieces makes it possible to quickly adapt to various types of blind rivet. Even special versions are generally available on request. All nosepiece allocation data relate to DIN and GESIPA® blind rivets.

Nosepiece assignment

Rivet	Rivet Ø mm	Rivet material	Nosepiece	Part no.
Standard	2.4	Alu	17/18	143 4976
	3.2	CAP®-Alu, CAP®-Cu	17/18	143 4976
	3	Alu/Cu	17/20	143 4994
	3	Alu, Cu, Steel, Stainless steel, Stinox, Alu/alu	17/22	143 5018
	3 and 3.2	Alu, Cu, Steel, Stainless steel, Stinox, PG-Alu, PG-Steel, PG-Stainless steel	17/24	143 4955
	4	Alu, Cu, CAP®-Alu, CAP®-Cu	17/24	143 4955
	4	Steel, Alu, PG-Alu	17/27	143 4973
	4	Stainless steel, Stinox, PG-Steel, PG-Stainless steel	17/29	143 4974
	4.8 and 5	Alu, CAP®-Alu, CAP®-CU, PG-Alu	17/29	143 4974
	4.8 and 5	Steel, Alu	17/32	143 4975
	4.8 and 5	Stainless steel, Stinox, PG-Steel, PG-Stainless steel, G-Bulb	17/36	143 4977
	6	Alu	17/36	143 4977
	6	Steel	17/40	143 4999
	6.4	Alu	17/40	143 4999
6.4	Steel, Alu, Stainless steel, PG-Stainless steel, G-Bulb	17/45	143 4860	
8	Alu	17/45	143 4860	
BULB-TITE®	4	Alu	17/26 BT	143 4985
	5.2	Alu	17/32 BT	143 4986
	6.3	Alu, Steel, Monel	17/42 BT	143 4988
	7.7	Alu	17/48 BT	143 4989
MEGA GRIP®	4.8	Alu, Steel, Stainless steel	17/31 MG	143 4993
	6.4	Alu, Steel, Stainless steel	17/41 MG	143 4865

Accessories – TAURUS® series 1-4

Swivel air connector



For the complete TAURUS® series in 1/8"

Part no. 143 5479

Set of jaws (3 pcs.)



Patented jaw system for the complete TAURUS® series

Part no. 143 5568

Flexible base for TAURUS® 1 and 2



With the flexible base made from MBR and the larger surface area, the TAURUS® tools are standing even more stably.

For **TAURUS® 1**
Part no. 143 6394

For **TAURUS® 2**
Part no. 143 6371

Protective sleeve



The plastic-dipped steel head sleeve protects sensitive work-piece surfaces (e.g. painted surfaces) from being scratched by the nosepiece or the steel head sleeve during riveting.

For **AccuBird® and PowerBird®**
Part no. 156 7288

For **TAURUS® standard tools and Bird Pro series**
Part no. 156 7289

Accessories – TAURUS® series 1-4

Transparent collecting container for TAURUS® 1-4



The classic residual mandrel collecting container in the TAURUS® series is also available in a transparent version. The transparent collecting container allows the amount of residual mandrels to be monitored constantly.

The transparent collecting container will be available in a small version for the TAURUS® devices 1-2 and a large version for the TAURUS® devices 3-4.

For **TAURUS® 1-2**
Part no. 145 7744

For **TAURUS® 3-4**
Part no. 145 7951

TAURUS® conversion kit



For conversion to the PH 2000 spent mandrel container (description and full offer on page 144).

For **TAURUS® 1**
Part no. 145 7700

For **TAURUS® 2-4**
Part no. 145 7703

Mandrel extraction tube



By attaching a special-purpose hose nipple, the spent mandrel container can be replaced by the spent mandrel evacuation hose*. In stationary use, this can be of great advantage as frequent disposal is not required. The spent mandrels are collected in a container so that the work place remains clean and tidy, with no interruption to the work.

*The use of TAURUS® tools with a 1.5 m long evacuation hose requires permanent employment of the suction unit.

For the full TAURUS® series

Part no. 145 7864

Accessories – TAURUS® series 1-4

Extension units

Allows easy access to rivet sites which are difficult to reach.

The extension units are used for riveting sites which are situated low down or are difficult to access. We offer one-piece extension units of 35, 85, 135 and 185 mm length for the **TAURUS® 1-4**. The extension units consist of three parts.



One-piece

The total length of the steel head sleeve for TAURUS® 1 with 35 mm, 85 mm and 135 mm is 106 mm, 156 mm and 206 mm respectively. TAURUS® 2 with 35 mm, 85 mm, 135 mm and 185 mm is 106 mm, 156 mm, 206 mm and 256 mm respectively. TAURUS® 3 and 4 with 35mm, 85 mm and 135 mm is 106 mm, 156 mm and 206 mm respectively.

Tool	+35 mm	+85 mm	+135 mm	+185 mm
TAURUS® 1*	146 4345	146 4346	146 4347	-
TAURUS® 2*	145 8042	146 4350	146 4351	146 4352
TAURUS® 3 and 4	145 7932	145 7933	145 7937	-

Tool	50 mm	100 mm
TAURUS® 1 with spring loaded trigger system	145 0880	145 7727
TAURUS® 2 with spring loaded trigger system	145 7857	145 7858
TAURUS® 3 and 4 with spring loaded trigger system	145 7959	145 7960

* Valid for tools manufactured after October 2015
For older models see page 316

Multi-piece

Total length of the steel head sleeve including the extension unit. On TAURUS® 1-4 the steel head sleeve can be extended variably in steps of 100 mm.

Tool	100 mm
TAURUS® 1	145 7743
TAURUS® 2	145 7848
TAURUS® 3 and 4	145 7947

Small jaw assembly TAURUS® 1-2

The small jaw assembly is particularly suitable where rivet sites are difficult to access. The TAURUS® 1 with the small jaw assembly handles aluminium/steel blind rivets up to Ø 4 mm and steel/steel blind rivets up to Ø 3.2 mm. The small jaw assembly for the TAURUS® 2 handles aluminium/steel blind rivets up to Ø 5 mm and steel/steel blind rivets up to Ø 4 mm. The jaw assembly is 100 mm long and the diameter of the steel head sleeve is 18 mm.



For **TAURUS® 1: Part no. 145 7705**

For **TAURUS® 2: Part no. 145 7846**

Accessories – TAURUS® series 1-4

Angle head 90° and Angle head 90° compact

The **angle head 90°** and the **angle head 90° compact** are designed for use in tight spaces. Its sturdy design allows it to apply large setting forces when setting blind rivets even in difficult of access work areas. The **angle head 90°** for TAURUS® 1-4 allows to set all Types of standard blind rivets up to Ø 6.4 mm all materials and Ø 8 mm alu, depending on the tool type. The minimum edge clearance is 15 mm, the head length is 110 mm.

The **angle head 90° compact** for the TAURUS® 1 and 2 allows to set standard blind rivets of all Types of material up to 5 mm in diameter and alu/steel blind rivets up to 6 mm in diameter, depending on the tool Type. The minimum edge clearance is 12 mm, the head length is 90 mm. Both angle heads can be freely fixed in any position around the TAURUS® tensile axis (360° free rotation).

3

Angle head 90° for TAURUS® 1-4

Technical data

Weight: 1.1 kg
 Stroke: 20 mm (TAURUS® 1, 2 and 4)
 Stroke: 25 mm (TAURUS® 3)
 Traction power: up to 20 kN

Equipment

Nosepiece 17/45 WK
 Jaws up to rivet-Ø 4mm (Nosepiece 17/24)

Angle head 90° for TAURUS® 1, 2 and 4
Part no. 155 9513

Angle head 90° for TAURUS® 3
Part no. 155 9512

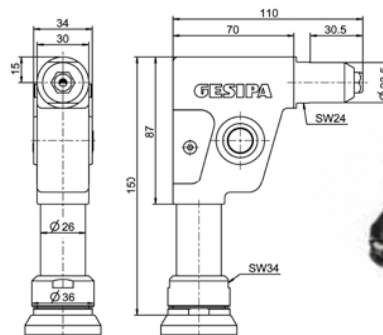

Angle head 90° compact for TAURUS® 1-2

Technical data

Weight: 0.7 kg
 Stroke: 20 mm
 Traction power: up to 10 kN

Equipment

Nosepieces: 17/36

Part no. 145 7921

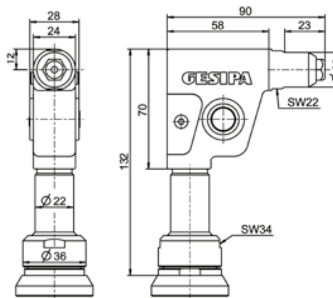

Dimensions in mm

Jaws (3 parts) for

Angle head 90° for TAURUS® 1-4
 Up to rivet Ø 4 mm (Nosepiece 17/24)

Part no. 143 4173

Up to Ø 6.4 mm of all materials,
 Ø 8.0 mm Alu

Part no. 143 4958

Angle head 90° for TAURUS® 1-2

Part no. 143 4104



TAURUS® versions

A wide variety of options means higher flexibility. All of the TAURUS® varieties are customized and designed and made to fit the application. Please contact our team from the Technical Sales department should you require individual advice or have any further queries or need information on prices.



TAURUS® versions – Safe, individual, versatile!

TAURUS® 2/K

The TAURUS® 2/K has been designed for setting plastic rivets. In its functionality the TAURUS® 2/K is identical to the standard tool, however has a stroke of 24 mm instead of 18 mm. Plastic rivets only need a low setting force, however, normally require large setting strokes due to the toughness of the plastic material.

The TAURUS® 2/K allows to safely set plastic rivets with only one setting stroke! The TAURUS® 2/K comes with 3 nose pieces for plastic rivets 17/30 K, 17/35 K and 17/40 K included.

Part no. 145 7804

Working range

Blind rivets plastic from 4 up to 6 mm Ø.

Nosepieces

17/30K; 17/35K; 17/40K

Technical data

Strength: 24 mm
Tensile strength: 8,400 N



TAURUS® 2/AS

The TAURUS® 2/AS is a special version of the TAURUS® 2 with a VAS slide switch which does not engage when in its highest position, thus achieving that vacuum absorption is automatically deactivated once the tool is not in use. This way, unintentional activation of the vacuum absorption with unnecessary air consumption can be effectively avoided.

Part no. 145 7794

Other TAURUS® sizes upon request.



3

TAURUS® 2/24

As far as technology and functionality are concerned, the TAURUS® 2/24 is identical to the standard tool, however has a stroke of 24 mm instead of 18 mm. This tool provides the advantage of being able to safely set critical rivet Types requiring a large setting stroke with only one setting stroke without re-engagement. This applies, for example, to our BULB-TITE® or similar rivets.

Part no. 145 7803

Working range

Blind rivets up to Ø4 mm all materials, Ø5 mm steel; Ø 6 mm alu.

Technical data

Strength: 24 mm
Tensile strength: 8,400 N

TAURUS® versions

TAURUS® 1-4 with counter device



The TAURUS® series 1-4 with counter device – detects and counts the spent mandrels

The tools are equipped with a sensor which detects and counts the spent mandrels after the setting process has been finished. The sensor is positioned on the tool head in front of the spent mandrel container.

For a completely independent workstation, the amplifier GRivAmp or the counter and display unit GRivCount can be used for processing and analysing the signals.

TAURUS® 1-4 (with counter device)

For retrofitting existing tools a conversion kit suitable for all TAURUS® Types (except TAURUS® with PH 2000 spent mandrel container) is available:



GRiv-Count

GRiv-Amp

Conversion kit TAURUS® 1 with sensor

Part no. 145 7698

Conversion kit TAURUS® 2-4 with sensor

Part no. 151 6858

GRiv-Count

Part no. 146 3062

GRiv-Amp

Part no. 145 7699



Power supply (24 V) is to be provided on site.

TAURUS® versions

TAURUS® 1-4 with counter eco

TAURUS® 1-4 with counter – the cost-effective variant for monitoring the number of setting strokes

In contrast to the TAURUS® with counter, the eco counter only counts the number of setting strokes and not the spent mandrels. The sensor is fitted on the air cylinder. The counter is not available on its own. It is supplied mounted on a new tool or it can be retrofitted at the Walldorf factory.



Retrofit kit for the eco counting device

Tool	Part no.
TAURUS® 1	145 0892
TAURUS® 2	145 0933
TAURUS® 3	145 0963
TAURUS® 4	145 0993

! Can only be mounted by GESIPA®.

TAURUS® versions

TAURUS® 4 CF

The hydropneumatic rivet setting tool specifically for semitubular and solid rivets!



C-Frame Type RT100
Part no. 143 6455

GESIPA® TAURUS® 4 CF
Part no. 145 7985

C-Frame complete incl. mounting and case
Part no. 152 0101



The TAURUS® 4 can be equipped with an „RT 100“ C-Frame tool for processing semitubular and solid rivets. Further application options include press-fitting, hole punching and caulking as well as pressing out lockbolts.

Each C-Frame can be optionally operated stationary and equipped with a foot-operated switch.

The C-Frame tools are characterised by a swivel range of 360°, efficient operating sequence and a precisely adjustable setting stroke.

Technical Data

Setting force:	23,000 N (at 6 bar)
Tool stroke:	19 mm
Operating pressure:	5-7 bar
Hose connection:	Ø 6 mm (1/4")
Weight:	approx. 2.0 kg (without C-Frame)

Advantages

- Flexibility
- Simple and safe pneumatic force control
- Easy tool change

Contact our Technical Sales department.

TAURUS® versions

TAUREX 1-6

The whole TAURUS® series with remote pressure transducer – for even more flexibility, versatility and ergonomy

Working range

- All blind rivets and lockbolts up to a mandrel breaking force of 50 kN
- Same performance and technical characteristics as the respective individual units in the TAURUS® series 1-4, 5-6 with different stroke
- 3 metres hose length between pressure transducer and setting pistol

Common technical data

Operating air pressure: 5 to 7 bar
 Air hose connection: 6 mm (1/4")
 Noise emission: max. 79 dB
 Vibrations: < 2.9 m/s²

Advantages

- Low weight of the hand held tool
- Tubing connection with quick-connect feature (upon request) on the pressure transducer side: No oil leak and no air bleeding
- Ideally suited for setting of blind rivets and lockbolts in poorly accessible locations
- Also perfectly designed for fixed installation in production lines or semi-automatic workstations
- Can be combined with almost all supplements and options of the TAURUS® series: head extensions, mandrel containers, rivet counting units, process control, pressure trigger and remote control



Now with even more flexible hose

Tool	Part no.
TAUREX 1	145 8025
TAUREX 2	145 8031
TAUREX 3	145 8044
TAUREX 4	145 8058
TAUREX 5	145 8060
TAUREX 6	145 8062

TAURUS® versions

Parallel head for TAURUS® 1-4*

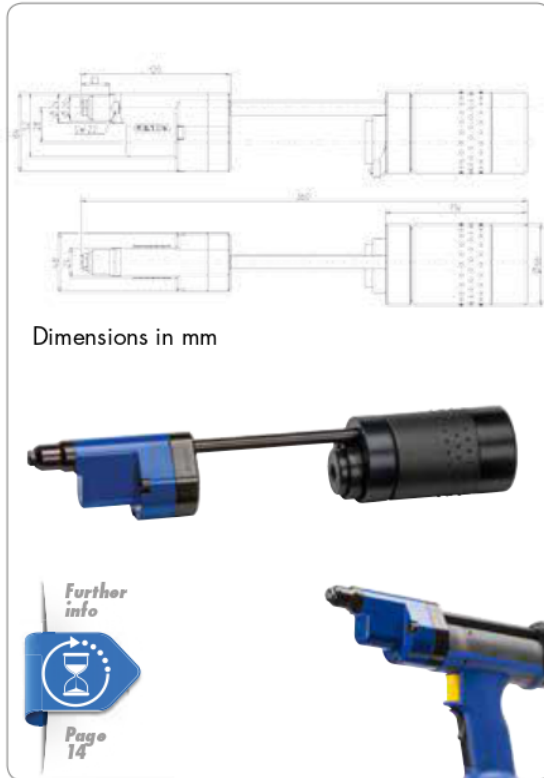

Dimensions in mm

The parallel head for the TAURUS® series 1-4 was specially developed for use in areas that are difficult to access. The compact and sturdy design makes it possible to set blind rivets with a high setting force even in working areas that are difficult to access. Depending on the Type of tool, the parallel head for the TAURUS® series 1-4 can set standard blind rivets up to Ø 6.4 mm all materials with a setting force of up to 20 kN. The smallest edge spacing is 13 mm.

Technical data

Weight: 1.0 kg
Stroke: up to 25 mm
Setting force:
up to 20 kN

Advantages

- Minimal edge spacing (13 mm)
- High setting force in restricted space
- Compact and sturdy design
- Easy jaw maintenance
- Low vibration even at high break-off forces
- Mandrel disposal into the spent mandrel container by tilting back or to the front through the nose-piece.

Equipment

Nosepiece 16/36



Can only be mounted by GESIPA®

Part no. 145 0885*

*Clearance – only while stocks last!

Head modules for TAURUS® 5-6 and TAUREX 5-6



Adaption takes priority

The TAURUS® 5 and 6 riveting tools must be adapted to the different kinds of rivets and lockbolts through specific pulling head modules

Head module for 7.8 mm Titgemeyer TIBULB*
Part no. 145 8008

Head module for 9.8 mm Huck Magna-Lok®*
Part no. 145 8009

* partly registered trademarks of TITGEMEYER GmbH & Co. KG or Alcoa Fastening Systems

Other head modules on request.



The suitability of nosepiece and fastener needs to be tested by the user and is user's own responsibility!

Accessories – TAURUS® series / TAUREX tools

Balancer for all TAURUS® 1-4-Axial- and TAUREX 1-4-Axial-tools



To cover various requirements, two balancer models for suspending the TAURUS® Axial tools are available. If the tube for evacuating the spent mandrel can be kept very short, no external mandrel evacuation assistance is necessary which means a balancer without valve is sufficient. However, if due to the tube length external evacuation assistance of the mandrel becomes necessary it can be switched on and off by means of the valve balancer in order to save cost-intensive compressed air.

Balancer without valve
Part no. 143 4734



The balancer with disconnecting valve is used when the blind rivet is to be inserted into the tool. In this case the valve interrupts the compressed air necessary to generate negative pressure when in its highest position.

Balancer with disconnecting valve
Part no. 145 7733



The time delay valve on the other hand is used when the blind rivet is to be inserted into the part. During the rivet setting procedure, the valve activates the compressed air required to create a vacuum and shuts it off after a set time.

Time delay valve
Part no. 145 0893

TAURUS® versions

TAURUS® 1-4 Axial eco

The TAURUS®-series 1-4 in axial version – the cost-efficient introductory version for special applications



Further info



Page 14

Applications

The special pistols of TAURUS® Axial eco offer the option of installation in production systems and simultaneously allow flexible and handheld ergonomic work in applications with restricted accessibility that require a vertical, downwards oriented riveting action.

In order to ensure that no gap is left between the components to be riveted and the setting head effectively makes contact with the application, the TAURUS® Axial eco can be additionally supplied with a spring-loaded trigger system.

A compressed air supply is additionally required for reliable mandrel evacuation. Depending on the application, this is preferably achieved via the balancer with valve or the time delay valve (see Page 139).

Working range

- Blind rivets up to 6.4 mm Ø all materials and up to 8 mm Ø alu (max. mandrel dia 4.5 mm)
- Same performance and technical data as the respective individual units in the TAURUS® series

Technical data

Operating air pressure:	5 to 7 bar
Air hose connection :	6 mm (1/4")
Noise emission:	max. 79 dB
Vibrations:	< 2.9 m/s ²
Weight:	
TAURUS® 1 Axial eco	2.0 kg
TAURUS® 2 Axial eco	2.3 kg
TAURUS® 3 Axial eco	2.6 kg
TAURUS® 4 Axial eco	3.0 kg

Advantages

- Cost-efficient basic version
- Perfectly designed for fixed installations on production lines or semi-automatic workstations
- Very practical for processing blind rivets in positions that require a vertical rivet setting process
- The tool can be equipped with almost all TAURUS® series options: e.g. extension units, blind rivet counter, setting process monitoring, spring loaded trigger system and remote control
- Can be suspended on a balancer
- Integrated mandrel evacuation for disposal of the spent mandrel

Tool	Part no.
TAURUS® 1 Axial eco	145 7676
TAURUS® 2 Axial eco	145 7798
TAURUS® 3 Axial eco	145 7898
TAURUS® 4 Axial eco	145 7980
TAURUS® 1 Axial eco with spring-loaded trigger system	145 7677
TAURUS® 2 Axial eco with spring-loaded trigger system	145 7799
TAURUS® 3 Axial eco with spring-loaded trigger system	145 7899
TAURUS® 4 Axial eco with spring-loaded trigger system	145 7981

TAURUS® versions

TAURUS® 1-4 Axial

The TAURUS® series 1-4 in axial version – for special applications

Applications

The special pistols of TAURUS® Axial offer the option of installation in production systems and simultaneously allow flexible and handheld ergonomic work in applications with restricted accessibility that require a vertical, downwards oriented riveting action.

In order to ensure that no gap is left between the components to be riveted and the setting head effectively makes contact with the application, the TAURUS® Axial can be additionally supplied with a spring loaded-trigger system.

A compressed air supply is additionally required for reliable mandrel evacuation. Depending on the application, this is preferably achieved via the balancer with valve or the time delay valve (see page 139).

Working range

- Processing blind rivets up to 6.4 mm Ø all materials and up to 8 mm Ø alu (max. mandrel dia. 4.5 mm)
- Same performance and technical data as the respective individual units in the TAURUS® series 1-4

Technical data

Operating pressure:	5 to 7 bar
Air hose connection:	6 mm (1/4")
Noise emission:	max. 79 dB
Vibrations:	< 2.9 m/s ²
Weight:	
TAUREX 1 Axial compact	3.1 kg
TAUREX 2 Axial compact	3.4 kg
TAUREX 3 Axial compact	3.7 kg
TAUREX 4 Axial compact	4.1 kg



Advantages

- Pressure transducer attached in a space-saving manner directly to the device, i.e. also for applications in tight spaces
- Technical design close to the TAUREX Axial
- Also perfectly designed for fixed installation in production lines or semi-automatic workstations
- Very practical for processing blind rivets in positions that require a vertical rivet setting process
- The tool can be equipped with almost all TAURUS® series options: e.g. extension units, blind rivet counter, spring loaded trigger system and remote control
- The handle in the rivet axis allows ergonomic work – especially in vertical applications
- Can be suspended on a balancer

Tool	Part no.
TAURUS® 1 Axial	145 7682
TAURUS® 2 Axial	145 7795
TAURUS® 3 Axial	145 7893
TAURUS® 4 Axial	145 0981
TAURUS® 1 Axial with spring-loaded trigger system	145 7683
TAURUS® 2 Axial with spring-loaded trigger system	145 7796
TAURUS® 3 Axial with spring-loaded trigger system	145 7894
TAURUS® 4 Axial with spring-loaded trigger system	145 0982

TAURUS® versions

TAUREX Axial 1-4 compact

The TAURUS® series 1-4 with an axial pressure transducer mounted directly on the device – for use in tight working spaces



Applications

The TAUREX Axial compact is a particular advantage in enclosed spaces due to the pressure transducer mounted close and parallel to the tool's axis.

The special pistols of TAUREX Axial compact offer the option of installation in production systems and simultaneously allow flexible and handheld ergonomic work in applications with restricted accessibility that require a vertical, downwards oriented riveting action.

In order to ensure that no gap is left between the components to be riveted and the setting head effectively makes contact with the application, the TAUREX Axial compact can be additionally supplied with a spring-loaded trigger system (see page 139).

Operating range

- Processing blind rivets up to 6.4 Ø all materials and up to 8 mm Ø alu (max. mandrel dia. 4.5 mm)
- Same performance and technical data as the respective individual units in the TAURUS® series 1-4

Technical data

Operating pressure:	5 to 7 bar
Air hose connection:	6 mm (1/4")
Noise emission:	max. 79 dB
Vibrations:	< 2.9 m/s ²
Weight:	
TAUREX 1 Axial compact	3.1 kg
TAUREX 2 Axial compact	3.4 kg
TAUREX 3 Axial compact	3.7 kg
TAUREX 4 Axial compact	4.1 kg



Advantages

- Pressure transducer attached in a space-saving manner directly to the device, i.e. also for applications in tight spaces
- Technical design close to the TAUREX Axial
- Also perfectly designed for fixed installation in production lines or semi-automatic workstations
- Very practical for processing blind rivets in positions that require a vertical rivet setting process
- The tool can be equipped with almost all TAURUS® series options: e.g. extension units, blind rivet counter, spring-loaded trigger system and remote control
- The handle in the rivet axis allows ergonomic work – especially in vertical applications.
- Can be suspended on a balancer

Tool	Part no.
TAUREX 1 Axial compact	145 1003
TAUREX 2 Axial compact	145 8034
TAUREX 3 Axial compact	145 8048
TAUREX 4 Axial compact	145 8059
TAUREX 1 Axial compact with spring-loaded trigger system	145 8027
TAUREX 2 Axial compact with spring-loaded trigger system	145 8035
TAUREX 3 Axial compact with spring-loaded trigger system	145 8049
TAUREX 4 Axial compact with spring-loaded trigger system	145 1022

TAURUS® versions

TAUREX Axial 1-4

The TAURUS® series 1-4 with remote mounted pressure transducer in axial version – making it more flexible, versatile and ergonomic

Applications

The TAUREX Axial is a particular advantage in restricted spaces due to the separate pressure transducer mounted in the working direction. The special pistols of TAUREX Axial offer the option of installation in production systems and simultaneously allow flexible and handheld ergonomic work in applications with restricted accessibility that require a vertical, downwards oriented riveting action. In order to ensure that no gap is left between the components to be riveted and the setting head effectively makes contact with the application, the TAUREX Axial can be additionally supplied with a spring-loaded trigger system.

It is essential to use an external suction system with the TAUREX Axial!

A compressed air supply is additionally required for reliable mandrel evacuation. Depending on the application, this is preferably achieved via the balancer with valve or the time delay valve (see page 139).

Working range

- Sets blind rivets up to 6.4 mm Ø all materials and up to 8 mm Ø alu (max. mandrel dia 4.5 mm)
- Same performance and technical data as the respective TAURUS® series 1-4
- 3 metre hose length between pressure transducer and setting pistol

Technical data

Operating air pressure:	5 to 7 bar
Air hose connection:	6 mm (1/4")
Noise emission:	max. 79 dB
Vibrations:	< 2.9 m/s ²
Weight:	
TAUREX 1 Axial	2.4 kg
TAUREX 2 Axial	2.7 kg
TAUREX 3 Axial	3.0 kg
TAUREX 4 Axial	3.1 kg



Advantages

- Also perfectly designed for fixed installation in production lines or semi-automatic workstations
- Very practical for processing blind rivets in positions that require a vertical rivet setting process
- Low weight of the hand held tool
- Tubing connection with quick-connect feature (upon request) on the pressure transducer side: No oil leak and no air bleeding
- The tool can be equipped with almost all TAURUS® series options: e.g. extension units, blind rivet counter, spring loaded trigger system and remote control
- The handle in the rivet axle allows ergonomic work – especially in vertical applications
- Can be suspended on a balancer

Tool	Part no.
TAUREX 1 Axial	145 8026
TAUREX 2 Axial	145 8032
TAUREX 3 Axial	145 8047
TAUREX 4 Axial	145 1019
TAUREX 1 Axial with spring-loaded trigger system	145 1002
TAUREX 2 Axial with spring-loaded trigger system	145 8033
TAUREX 3 Axial with spring-loaded trigger system	145 1016
TAUREX 4 Axial with spring-loaded trigger system	145 1020

TAURUS® versions

TAURUS® 1-4 with spring-loaded trigger system



The spring-loaded trigger system ensures that the components which are to be riveted are reliably placed one on top of the other gapfree prior to the riveting process. Furthermore, this ensures that the blind rivet reaches its end position in the bore prior to the setting process and that the setting head is in the right position. The pressure force can be variably applied depending on the application.

The spring-loaded trigger system cannot be retrofitted but is supplied completely attached.

TAURUS® 1 with spring-loaded trigger system

Part no. 145 7680

TAURUS® 2 with spring-loaded trigger system

Part no. 145 7778

TAURUS® 3 with spring-loaded trigger system

Part no. 143 5869

TAURUS® 4 with spring-loaded trigger system

Part no. 145 7965

New features:

Adjustable range from 15 to 75 N / Guaranteed easy-to-apply contact / force by use of springs

TAURUS® 1-4 with PH 2000 spent mandrel container

The fixed mounted, large PH 2000 mandrel container is very sturdy and particularly suited to long mandrels from 50 to 70 mm in length. The container fits all TAURUS® versions 1 to 4.



TAURUS® 1 with PH 2000 spent mandrel container

Part no. 145 7669

TAURUS® 2 with PH 2000 spent mandrel container

Part no. 145 7780

TAURUS® 3 with PH 2000 spent mandrel container

Part no. 145 7878

TAURUS® 4 with PH 2000 spent mandrel container

Part no. 145 7970

You will find the corresponding conversion kits on page 129.

TAURUS® versions

TAURUS® tools for stationary use in production systems

The TAURUS® tools can be integrated as stationary units in automatic production systems and operated by remote control, if required. As an option, a low-pressure connection can be used to detect the blind rivet in the nosepiece. If required, the spent mandrel can be disposed of by

means of an evacuation tube and also monitored by a sensor. In stationary production systems, several tools can be operated automatically and in parallel in order to achieve the highest possible level of efficiency.

3

Tool mount for TAURUS® 1-4



For integration into automated systems or connection to handling modules.

Part no. 143 5538*

*Device support not available individually. The tool is delivered pre-mounted on a new device or can be retrofitted on an existing device at the GESIPA® Walldorf site.



Can only be mounted by GESIPA®

TAURUS® 1-4 C AV

TAURUS® 1-4 C AV - with integrated setting process monitoring

Setting process monitoring is achieved by direct real-time analysis of traction force and traction course recorded during the setting of the rivet. All system components necessary for this operation are integrated in the tools. Analysing a setting process takes less than 1 µs. The results are directly shown by a green or red LED installed in the tool base and optionally by an acoustic signal. In addition to this individual analysis the system also provides collective analysis for the complete workpiece. The tool stores more than 260,000 setting process data which can be retrieved at any time. The system also identifies failure patterns and memorizes them for failure analysis and troubleshooting. The tools can be operated as stand-alone devices or as integrated part of a customer's production system via the GESIPA® interface.



With new spring-loaded trigger system

TAURUS® C 1-4 (with setting process monitoring)

GESIPA®-Interface

The new interface developed by GESIPA® is based on an embedded PC system and provides 24 digital in and out control system ports, Ethernet connection via a RJ45 connector as well as status LEDs. Connection ports for a protocol converter supporting all common bus systems and for external storage media as well as a USB port for fast data transfer complete the features of the new interface.

In addition, the GESIPA® interface has a process database for storing 250,000 of the most current process data (date, time, rivet position, process curve, analysis, etc.).

Of course, the new interface is backward compatible with its predecessor models.



High-grade GESIPA® blind rivet with minimal scatter:

- Minimal scatter of the graphs
- All graphs end in the break-off window
- 20x OK riveting

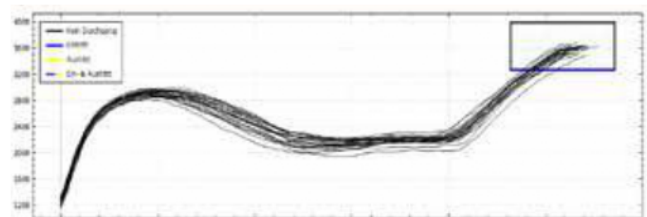

TAURUS® WinTech

WinTech – multi-window technology with up to three assessment windows

Ideal for demanding joining technology used for safety components such as in the aviation industry.

The basis for monitoring the WinTech setting process is the tried and tested TAURUS® C. The setting process is evaluated with the aid of position and force sensors as well as integrated electronic circuitry. Up to three evaluation windows can be configured with special setup software. A coloured LED on the tool shows the result of setting process monitoring. With a data line, the values can also be recorded and further processed.

Consultation, price and delivery time on request

Application

In the production of critical components as well as in automatic setting processes, the TAURUS® C can facilitate monitoring and documentation of the results.

Advantages

- High process reliability
- Documentation of each individual setting operation
- Less scrap as faults are detected immediately
- Avoidance of additional costs/quality costs due to NOK parts
- The customer can configure how to enter and exit the assessment window
- Flush-break rivets (MEGA GRIP®) can also be monitored

Example of OK process

Window entry and exit at customer-defined positions

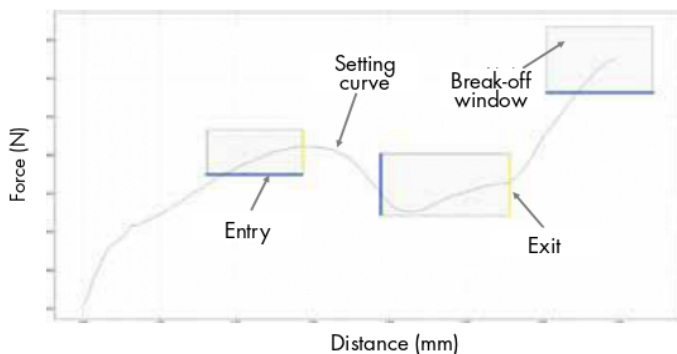

Example of not OK process

Material to be joined too thin due to missing component

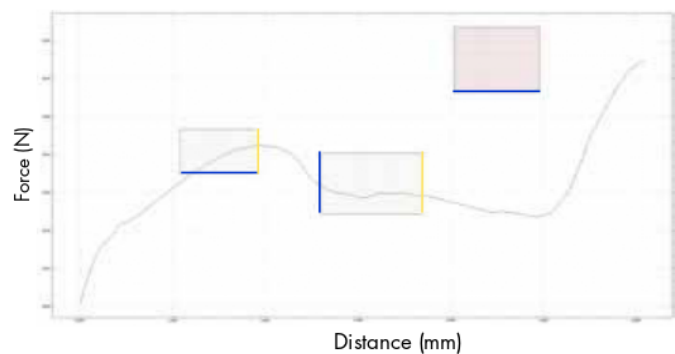

PH 1

Hydro-pneumatic blind rivet setting tool

Part no. 145 6766



Working range

Blind rivets up to 4 mm Ø all materials.

Not suitable for stainless steel

CAP® blind rivets.

Technical data

Weight:	1.2 kg
Operating air pressure:	5 - 7 bar
Air hose connection:	6 mm Ø (1/4")
Air consumption:	0.8-1.2 ltr. per rivet (0.2 ltr. compr. air)
Traction power:	6,200 N at 6 bar
Stroke:	15 mm

Nosepieces/accessories

Nosepieces: 16/18, 16/24, 16/27 and 16/29

1 set of jaws, 1 spent mandrel bottle,

1 wrench each of MSU and MSZ,

Maintenance instructions with spare parts list

Features

- Hydraulic head in aluminium with wear-proof cylinder surface
- Pneumatic cylinder made of die cast aluminium
- The piston made of hardened and hard chromium plated steel make the device easy to handle and wear-proof
- Compact seals are wear-proof for a long service life
- Fast venting valve for fast return and high working sequence
- Low-noise pneumatic switching
- Simple, low-interruption valve design
- Hydraulic head can be adjusted by 360°
- Favourable centre of gravity and handle design for fatigue-free handling

Jaws (2 parts) for PH 1

Part no. 143 4071

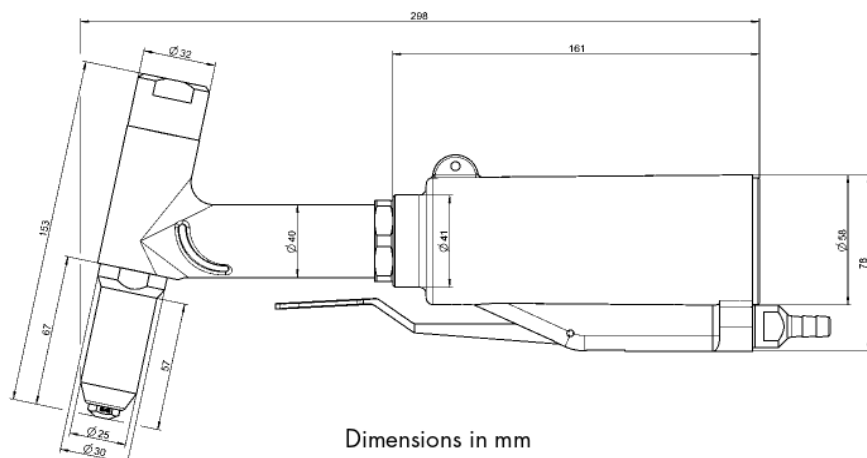

Dimensions in mm

PH 2

Hydro-pneumatic blind rivet setting tool

Part no. 145 6771



Working range

Blind rivets from 3 up to 5 mm Ø all materials and blind rivets with 2.4 mm up to 3.2 mm Ø with small jaws (page 155).

Not suitable for stainless steel **CAP® blind rivets**.

Technical data

Weight:	1.3 kg
Operating air pressure:	5 - 7 bar
Air hose connection:	6 mm Ø (1/4")
Air consumption:	1.2 - 1.8 ltr. per rivet (0.3 ltr. compr. air)
Traction power:	8.800 N at 6 bar
Stroke:	15 mm

Equipment

Nosepieces: 16/24, 16/27, 16/29, 16/32 and 16/36
1 set of jaws, 1 spent mandrel bottle,
1 wrench each of MSU and MSZ,
Maintenance instructions with spare parts list

Features

- Hydraulic head made of aluminium with wear-proof cylinder surface
- Pneumatic cylinder made of die cast aluminium
- Pistons: Steel hardened and chrome-plated – smooth operation and wear-proof
- Compact seals are wear-proof for a long service life
- Fast venting valve for fast return and high working sequence
- Low-noise pneumatic switching
- Simple, low-interruption valve design
- Hydraulic head can be adjusted by 360°
- Favourable centre of gravity and handle design for fatigue-free handling

Jaws (3 parts) for PH 2 and PH 2000

Part no. 143 4103

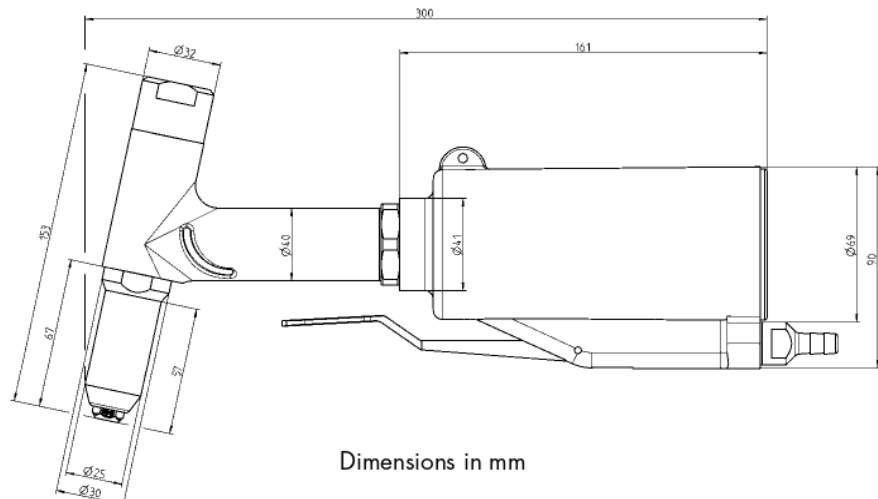

PH 2000

Hydro-pneumatic blind rivet setting tool

Part no. 145 6724

Working range

Blind rivets up to \varnothing 5.0 mm all materials, \varnothing 6.0 mm aluminium and blind rivets with \varnothing 2.4 mm up to 3.2 mm with small jaw assembly (page 155).

Technical data

Weight:	2.1 kg
Operating air pressure:	6 bar
Air hose connection:	6 mm \varnothing (1/4")
Air consumption:	2.8-3.6 ltr. per rivet (0.6 ltr. compr. air)
Traction power:	12,000 N at 6 bar
Stroke:	22 mm

Equipment

Nosepieces: 16/24, 16/27, 16/29, 16/32, 16/36, 16/40 and 16/45
1 set of jaws, 1 air deflector (no. 896)
1 wrench MSU
1 ball headed screw driver SW 2.5
1 oil refill can with hydraulic oil
Maintenance instructions with spare parts list

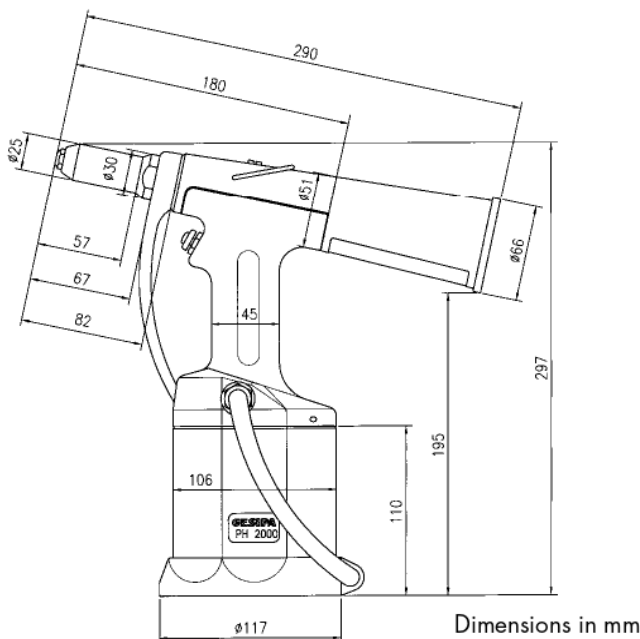

Features

- The patented broken mandrel disposal system with the extraction option is an integral part of the tool. No retrofitting required.
- The compressed air used for the setting process is then used to automatically eject the broken mandrel, an efficient and cost saving solution.
- High setting force with low weight
- Universal use, easy handling
- Large stroke (22 mm) – guarantees setting without re-engagement and increases the oil refilling intervals
- Pneumatic piston return – high working sequence
- Hydraulic head: Aluminium with wear-proof cylinder surface
- Pneumatic cylinder: Aluminium with impact-resistant plastic sheath
- Trigger valve: Direct pneumatic triggering – fast and functionally reliable

PH 2-VK

Hydro-pneumatic blind rivet setting tool

Part no. 145 6774

VK: Shorter version of the pistol head for difficult to access rivets

Working range

Blind rivets up to 4 mm Ø alu, steel and copper

Technical data

Weight: 1.3 kg
Operating air pressure: 5 - 7 bar
Air hose connection: 6 mm Ø (1/4")
Air consumption: 1.2-1.8 ltr. per rivet
(0.3 ltr. compr. air)
Traction power: 6,200 N at 6 bar
Stroke: 14 mm

Equipment

Nosepieces: 10/18, 10/24 and 10/27
1 spent mandrel bottle,
1 maintenance wrench of MSU and MSZ,
maintenance instructions with spare parts list

Jaws (2 parts) for PH 2-VK

Part no. 143 4071

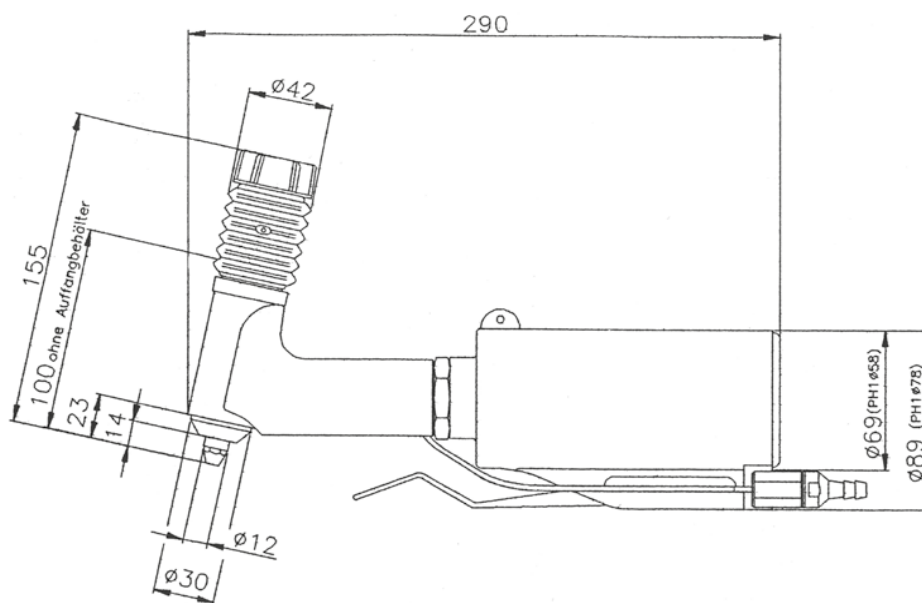

Dimensions in mm



PH Axial

Hydro-pneumatic blind rivet setting tool

Part no. 145 8063

Working range

Blind rivets from 4 up to 5 mm Ø steel and 2.4 up to 3.2 mm Ø with small jaw assembly (page 155).

Technical data

Weight:	1.8 kg
Operating air pressure:	5 - 7 bar
Air hose connection:	6 mm Ø (1/4")
Air consumption:	1.2-1.8 ltr. per rivet (0.3 ltr. compr. air)
Traction power:	8,800 N at 6 bar
Stroke:	15 mm

Equipment

Nosepieces: 16/24, 16/27, 16/29 and 16/32
Jaw pusher with reducing tube no. 125 for 4 mm Ø blind rivets in alu and copper
Ejection tube with socket for spent mandrels
Maintenance instructions and spare parts list

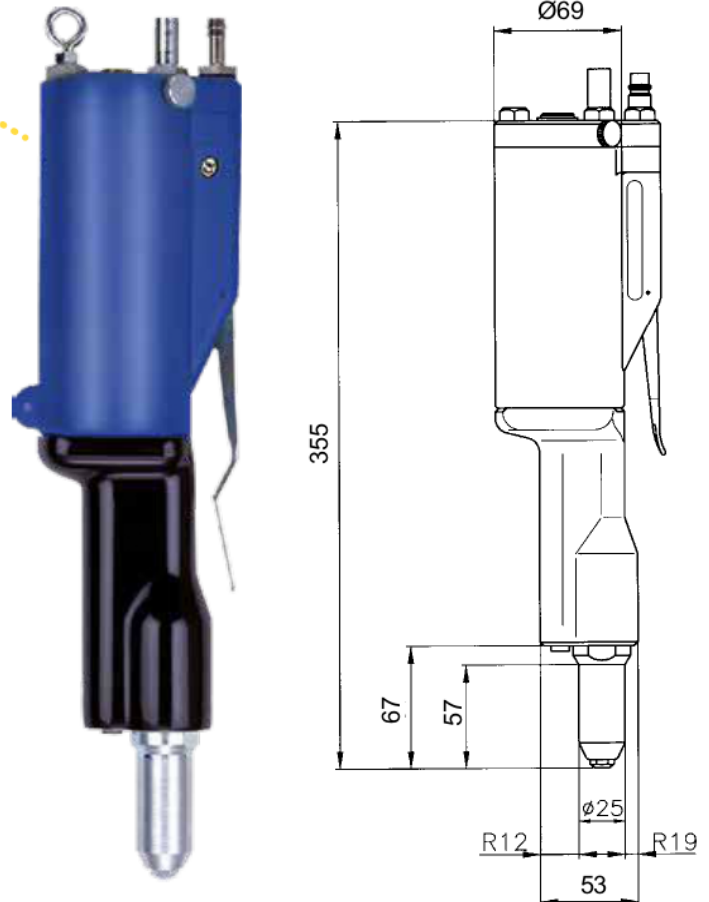

Dimensions in mm

Jaws (3 parts) for PH Axial

Part no. 143 4103

Features

- Pneumatic cylinder and hydraulic head with jaw mechanism arranged axially behind each other: simple and easy handling when used vertically (e.g. desktop assembly points)
- Integrated blind rivet suction and rivet mandrel ejection system: does not need to be retrofitted, secure disposal of the spent mandrels in a central container via a hose
- Hydraulic head in aluminium with wear-proof cylinder surface
- Pneumatic cylinder made of die cast aluminium
- Working piston made of hardened and hard chromium plated steel make the device easy to handle and wear-proof
- Compact seals are wear-proof with large scraper effect, long service life
- Fast venting system: faster return; high work sequence
- Low-noise pneumatic switching
- Simple valve structure: interruption free

Accessories – Hydro-pneumatic blind rivet setting tool

Nosepiece assignment PH tools. Information about nosepiece allocations are valid for DIN compliant and GESIPA® blind rivets.

Rivet Ø	Material	PH 1	PH 2	PH 2-VK	PH-Axial	PH 2000	PH 2000-BT
2.4	Al	16/18	10/18*	10/18	10/18*	10/18*	–
3.2	CAP®-Al, CAP®-Cu	16/18	10/18*	10/18	10/18*	10/18*	–
3 and 3.2	Al, Cu, Steel, Stainless steel, Stinox, Alu, PG-Al, PG-Steel	16/24	10/24*	10/24	10/24*	10/24*	–
4	Al, Cu, CAP®-Al, CAP®-Cu	16/24	16/24	10/24	16/24	16/24	–
4	PG-Al, Steel, Al	16/27	16/27	10/27	16/27	16/27	–
4	Stainless steel, Stinox, PG-Steel	16/29	16/29	–	16/29	16/29	–
4.8 and 5	Al, CAP®-Al, CAP®-Cu, PG-Al	–	16/29	–	16/29	16/29	–
4.8 and 5	Steel, Al	–	16/32	–	16/32	16/32	–
4.8 and 5	Stainless steel, Stinox, PG-Steel	–	16/36	–	–	16/36	–
6	Al	–	–	–	–	16/36	–
6	Steel	–	–	–	–	16/40	–
6.4	Al, PG-Al	–	–	–	–	16/40	–
6.4	Al, Steel	–	–	–	–	16/45	–
4	Plastic	–	–	–	–	16/30K	–
5	Plastic	–	–	–	–	16/35K	–
6	Plastic	–	–	–	–	16/40K	–
4.8	all MEGA GRIP®	–	–	–	–	16/31MG	–
6.4	all MEGA GRIP®	–	–	–	–	16/41MG**	–
4	all BULB-TITE®	–	–	–	–	–	16/26BT
5.2	all BULB-TITE®	–	–	–	–	–	16/32BT
6.3	all BULB-TITE®	–	–	–	–	–	16/42BT
7.7	all BULB-TITE®	–	–	–	–	–	16/48BT

* Small jaw assembly required (see page 155)

** Conversion kit necessary (145 6762)

Special accessories for blind rivet setting tools

Transparent spent mandrel container for the TAURUS® and Bird Pro series



Example: TAURUS® 2 with small transparent spent mandrel container and PowerBird® Pro Gold Edition with transparent spent mandrel container

The spent mandrel container of the TAURUS® and Bird Pro series is also available in a transparent version.

The transparent collecting container allows the amount of residual mandrels to be monitored constantly.

The transparent spent mandrel container is available in a small version for TAURUS® tools (TAURUS® 1-2) and a large version (TAURUS® 3-4). A version is also available for the Bird Pro series.

VAS

Vacuum absorption system for PH1 and PH2

Part no. 145 7579

This device absorbs the spent mandrel after the riveting operation and transports it automatically into the mandrel container. A further advantage is offered when the rivet, inserted into the nosepiece, is held in the jaw mechanism even if the tool head is in the vertical downwards position. The vacuum absorption device is available as a complete built-in and can also be retrofitted to existing GESIPA® riveting power tools at any time.

Technical data

Weight of kit: 430 g
Operating air pressure: 4-6 bar

Equipment

1 air deflector (part no. 896)
1 wrench MSU
Maintenance instructions with spare parts list

Special accessories for blind rivet setting tools

Small jaw assembly for PH 1, PH 2, PH 2000 and PH-Axial

With reduced head diameter (18 mm)
and 2 part jaws.

Working range

up to 4 mm Ø stainless steel and 5 mm Ø alu

Equipment

Standard: nosepiece 10/24 (optional also with
nosepiece 10/18, 10/27, 10/29, 10/32)

PH 1 and PH 2
Part no. 145 6783

PH 2000
Part no. 143 4234

PH Axial
Part no. 145 8075

3

Universal nosepiece for blind rivet tools HN 2, PH 1, PH2, PH2-KA, PH2000 and AccuBird®



The universal nosepiece replaces five nosepiece sizes.
The integrated rotary star in the steel sleeve can be un-
locked easily without tools in order to select the appropriate
size of nosepiece.

Working range

Blind rivets from 2.4 up to 5 mm Ø alu, copper
and steel and up to 4 mm Ø stainless steel.

Operation

Operate the tool and hold trigger, then push back
adjusting ring to end position (1).
By turning the rotary star (2).

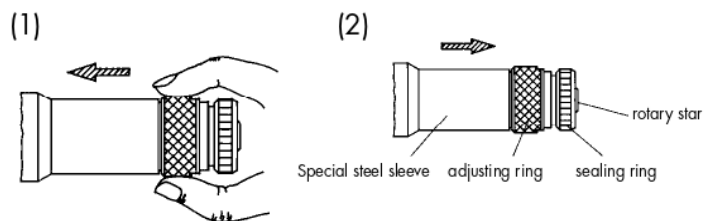

The universal nosepiece includes: Special steel sleeve,
complete adjusting ring, rotary star and sealing ring.

For HN 2, PH 1, PH 2 and PH 2000

Universal nosepiece – 16
Part no. 145 6776

For AccuBird®

Universal nosepiece – 17
Part no. 143 4960

Special accessories for blind rivet setting tools

One-piece extension unit

Replaces the steel case, is especially slim and therefore particularly well suited to narrow, hard-to-reach places.

Overall Length = Steel case + Standard nosepiece



Tool	+35 mm	+85 mm	+135 mm	+185 mm
TAURUS® 1*	146 4345	146 4346	146 4347	-
TAURUS® 2*	145 8042	146 4350	146 4351	146 4352
TAURUS® 3 and 4	145 7932	145 7933	145 7937	-

Tool	50 mm	100 mm
TAURUS® 1 with spring loaded trigger system	145 0880	145 7727
TAURUS® 2 with spring loaded trigger system	145 7857	145 7858
TAURUS® 3 and 4 with spring loaded trigger system	145 7959	145 7960

* Valid for tools manufactured after October 2015
For older models see page 316

Tool	50 mm	100 mm	150 mm
AccuBird®	145 7273	145 7274	145 0622
PowerBird®	145 7214	145 7215	146 4038
PowerBird® Gold Edition	145 7214	145 7215	146 4038
PowerBird® with spring loaded trigger system	145 7222	145 7224	-

The total length of the steel head sleeve for:

Battery powered tools

for 50 mm is 117 mm
for 100 mm is 167 mm
for 150 mm is 217 mm

Battery powered tools (Pro)

for 35 mm is 106 mm
for 85 mm is 156 mm
for 135 mm is 206 mm

Tool	+35 mm	+85 mm	+135 mm
AccuBird® Pro	145 0860	145 0861	145 0862
PowerBird® Pro	145 7650	145 7651	145 0823
PowerBird® Pro Gold Edition	145 7650	145 7651	145 0823
TAURUS® 3 and 4	145 7932	145 7933	145 7937

TAURUS® tools

TAURUS® 1 with 35 mm, 85 mm and 135 mm is 106 mm, 156 mm and 206 mm respectively
TAURUS® 2 with 35 mm, 85 mm, 135 mm and 185 mm is 106 mm, 156 mm, 206 mm and 256 mm respectively
TAURUS® 3 and 4 with 35 mm, 85 mm and 135 mm is 106 mm, 156 mm and 206 mm respectively

Tool	+50 mm	+100 mm
PowerBird® Pro Gold Edition with spring loaded trigger system	145 0821	145 0822

Special accessories for blind rivet setting tools

Multi-piece extension units

For riveted joints in low-lying places. Screwed in between the device and the existing steel case

Total length = steel head sleeve + extension + standard nosepiece



Tool	100 mm
PH 1 and PH2	145 6779
PH 2000	145 6765
AccuBird®	145 7318
PowerBird®	145 7229
PowerBird® Gold Edition	145 7273
AccuBird® Pro	145 0859
PowerBird® Pro	145 0820
PowerBird® Pro Gold Edition	145 0820
TAURUS® 1	145 7743
TAURUS® 2	145 7848
TAURUS® 3 and 4	145 7947

PH tools

Total length of the steel head sleeve including the extension unit is 50 mm 117 mm.

Battery powered tools

Variable extension of the steel head sleeve is possible in steps of 100 mm. The total length of the steel head sleeve, including the extension unit, is 167 mm for 100 mm.

Battery powered tools (Pro)

Variable extension of the steel head sleeve is possible in steps of 100 mm. The total length of the steel head sleeve, including the extension unit, is 171 mm for 100 mm.

TAURUS® tools

Total length of the steel head sleeve including the extension unit. On TAURUS® 1-4 the steel head sleeve can be extended variably in steps of 100 mm.

Offset head for PH1 and PH2

For setting rivets in places with difficult access and in corners



Offset head for PH1 with 2 part jaws
Part no. 145 6611

Offset head for PH2 with 3 part jaws
Part no. 145 6612

Special accessories for blind rivet setting tools

Special length nosepieces for blind rivet setting tools

NTS, NTS-K, NTX, NTX-F, Flipper®, SN 1, PH 1-VK, PH 2-VK and PH 1-L

Rivet-Ø	Material	Ø d	Ø D	Designation	15 mm	20 mm	25 mm
3 and 3.2	Alu, Cu, Steel, Stainless steel, Stinox, Alu/alu, PG-Alu, PG-Steel	2.4	6.5	10/24 SL...	-	145 6630	145 6632
4	Alu, Cu	2.4	6.5	10/24 SL...	-	145 6630	145 6632
4	Steel, CAP®-Alu, CAP®-Cu, Alu/alu, PG-Alu	2.7	7.0	10/27 SL...	145 6634	145 6635	-
4	Stainless steel, Stinox, PG-Steel	2.9	8.0	10/29 SL...	145 6638	-	-
4.8	CAP®-Alu, CAP®-Cu	2.9	8.0	10/29 SL...	145 6638	-	-
4.8 and 5	Alu, PG-Alu	3.2	8.0	10/32 SL...	145 6641	-	-

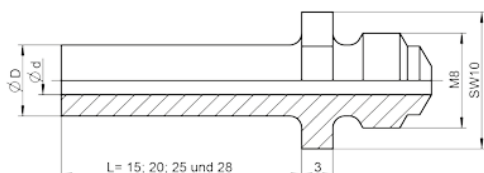

Dimensions in mm

SN 2, HN 2, PH 1, PH 2, PH 2-KA, PH-Axial and PH 2000

Rivet-Ø	Material	Ø d	Ø D	Designation	15 mm	20 mm	25 mm	28 mm
3 and 3.2	Alu, Cu, Steel, Stainless steel, Stinox, Alu/alu, PG-Alu, PG-Steel	2.4	6.0	16/24 SL...	145 6812	145 6813	145 6814	145 6815
4	Alu, Cu	2.4	6.0	16/24 SL...	145 6812	145 6813	145 6814	145 6815
4	Steel, PG-Alu	2.7	8.0	16/27 SL...	145 6816	145 6817	145 6818	145 6819
4	Stainless steel, Stinox, PG-Steel	3.0	8.0	16/29 SL...	145 6820	145 6821	145 6822	145 6823
4.8 and 5	Alu, PG-Alu	3.0	8.0	16/29 SL...	145 6820	145 6821	145 6822	145 6823
4.8 and 5	Steel	3.35	8.0	16/32 SL...	145 6824	145 6825	145 6826	145 6827
4.8 and 5	Stainless steel, Stinox, PG-Steel	3.6	10.0	16/36 SL...	145 6828	-	-	-
6	Alu	3.6	10.0	16/36 SL...	145 6828	-	-	-
6.4	Alu, PG-Alu	4.0	10.0	16/40 SL...	145 6807	-	-	-
6.4	Steel, Alu/alu	4.5	10.0	16/45 SL...	145 6805	145 6806	-	-

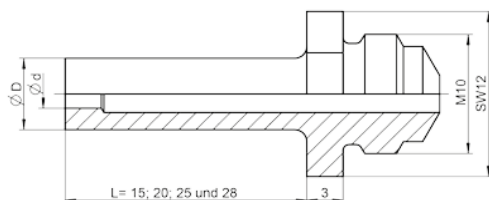

Dimensions in mm

Special accessories for blind rivet setting tools

AccuBird®, PowerBird® and TAURUS®

Rivet-Ø	Material	Ø d	Ø D	Designation	15 mm	20 mm	25 mm	28 mm
2.4	Alu	1.8	6.0	17/18 SL...	145 7367	145 7368	146 4039	146 4040
3.2	CAP®-Alu, CAP® copper	1.8	6.0	17/18 SL...	145 7367	145 7368	146 4039	146 4040
3	Alu/Cu	2.0	6.0	17/20 SL...	145 7314	145 7305	146 4041	145 7369
3	Alu, Cu, Steel, Stainless steel, Stinox, Alu/alu	2.2	6.0	17/22 SL...	145 7351	-	145 7349	145 0668
3 and 3.2	Alu, Cu, Steel, Stainless steel, Stinox, Alu/alu, PG-Alu, PG-Steel	2.4	6.0	17/24 SL...	145 7370	145 7371	145 7372	145 7373
4	Alu, Cu	2.4	6.0	17/24 SL...	145 7370	145 7371	145 7372	145 7373
4	Steel, PG-Alu	2.7	8.0	17/27 SL...	145 7374	145 7376	145 7377	143 5035
4	Stainless steel, Stinox, PG-Steel	3.0	8.0	17/29 SL...	145 7378	145 7379	145 7381	145 7382
4.8 and 5	Alu, PG-Alu	3.0	8.0	17/29 SL...	145 7378	145 7379	145 7381	145 7382
4.8 and 5	Steel	3.35	8.0	17/32 SL...	145 7383	145 7385	145 7386	145 7388
4.8 and 5	Stainless steel, Stinox, PG-Steel	3.6	10.0	17/36 SL...	145 7390	145 7392	145 7393	145 7394
6	Alu/alu	3.6	10.0	17/36 SL...	145 7390	145 7392	145 7393	145 7394
6	Steel	4.0	10.0	17/40 SL...	145 7399	145 7400	145 7401	145 7402
6.4	Alu, Stainless steel, PG-Alu, PG-Steel and G-Bulb	4.5	10.0	17/45 SL...	145 7265	145 0673	145 7404	145 7398

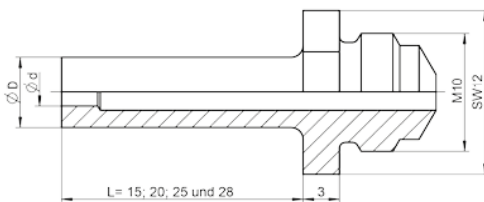

Dimensions in mm

CAUTION! Blind rivets must be ordered as a custom-made product with extended mandrel!

GESIPA® automatic riveting machines



GAV 8000 eco
GAV 8000 electronic
GAV HF

- All GESIPA® blind rivet machines are perfectly suited for use in industrial large-scale production.
- GAVs can either be operated manually or used as component in a robot-controlled system; integration into a production system is also possible.
- The automatic riveting machines support the setting of a wide range of blind rivets from 2.4 – 8 mm in diameter.
- Up to 40 riveting processes per minute can be realized depending of the Type of application.

GESIPA® automatic riveting machines

Comparison of GAV 8000 eco, electronic and GAV HF

On request our technical sales team will send you more information about application possibilities in your company.



	GAV 8000 eco and GAV 8000 electronic	GAV HF
Supply unit		
Weight	100 kg	270 kg
Spent mandrel container volume	approx. 1,800 to 5,500 pcs. (3.5 l) depending on size	approx. 1,800 to 5,500 pcs. (3.5 l) depending on size
Electrics		
Nominal voltage	230 Volt ~ 50 Hz	230 Volt ~ 50 Hz
Nominal current	< 2.5 A	< 8 A
Schutzart	IP 54	IP 54
Pneumatics		
Supply pressure	< 10 bar	< 10 bar
Operating pressure	6 bar	6 bar
Air consumption/riveting	15 NL	30 NL
Air consumption/spent mandrel extraction	340 NL / min.	340 NL / min.
Connection line	½" (12.5 mm) max. length 5 m	¾" (18.75 mm) max. length 5 m
Rest mandrel extraction tube	Outer Ø 8 mm/ Inner Ø 5 mm	Outer Ø 10 mm/ Inner Ø 6 mm
Pressure transducer	hydro-pneumatic	hydro-pneumatic
Rivet pistol		
Weight	ca. 2.5 kg	ca. 7 kg
Stroke	16 - 20 mm	20 mm
Traction power	12,000 N	25,000 N
Standard tube package length	3.75 m (max. 5.0 m)	6 m (max. 25 m)
Working cycle (theoretical)	1.25 sec.	2 sec.

GAV 8000 eco

Fully-automatic blind rivet processing system and cost-optimized variant of the GAV 8000 electronic without setting process monitoring

Working range

- 2.4 mm up to 6.4 mm Ø alu and copper
- Up to 6 mm Ø steel
- Up to 5 mm Ø stainless steel
- Up to flange diameter 11.4 mm
- Rivet body lengths above 30 mm
- Traction power up to 12,000 N at 6 bar air pressure

Productivity and savings potential

- Up to 40 blind rivets can be processed every minute
- No trained personnel required for operation
- Can be easily integrated into fully-automatic production systems

System description

- Electronic system controls
- Intuitive menu guidance via navigation and function keys
- Function display
- Maintenance display and simple fault diagnosis
- Customer-specific software modification is possible
- Ideal for applications that do not require any process monitoring
- Rivet mandrels are disposed of by vacuum system
- Spring loaded trigger system as an optional extra available
- Can be integrated into the system or operated independently
- Interface for external memory programmable control system (SPS) can be realised via the GESIPA® interface



Advice and delivery time on request

Subsequent upgrade to GAV 8000 electronic possible in our Walldorf factory at extra price



GAV 8000 electronic

Fully automatic blind rivet system for industrial production with setting process monitoring

Working range

- 2.4 mm up to 6.4 mm Ø alu and copper
- Up to 6 mm Ø steel
- Up to 5 mm Ø stainless steel
- Up to flange diameter 11.4 mm
- Rivet body lengths above 30 mm
- Traction power up to 12,000 N at 6 bar air pressure

Productivity and savings potential

- Cost effective from an annual quantity of around 500,000 blind rivets (in relation to the german market)
- Up to 50 % time and costs savings compared to standard blind rivet devices
- Rivet pistol has a large action radius thanks to the hose package that is up to 5.0 m in length (Standard length 3,75 m)
- No trained personnel required for operation
- Can be easily integrated into fully-automatic production systems
- Up to 40 blind rivets can be processed every minute

System description

- Electronic system controls
- Intuitive menu guidance via navigation and function keys
- Function display
- Maintenance display and simple fault diagnosis
- Customer-specific software modification is possible
- Rivet mandrels are disposed of by vacuum system
- Spring loaded trigger system as an optional extra available
- Can be integrated into the system or operated independently
- Interface for external memory programmable control system (SPS) can be realised via the GESIPA® interface



Advice and delivery time on request



Pistol versions for GAV 8000 eco



Specific workstation configuration

For all GAV versions, three different setting pistol variants are available for the ideal configuration of the workstation.

For manual workstations, pistols are available as overhead versions with overhead hose assembly or standard pistols with floor-mounted hose assembly. Both versions are equipped with a balancer to ensure fatigue-free working. The robotic pistol has been developed exclusively for use in fully automatic production systems or robot-controlled systems. It is supplied from stock with corresponding drilled holes for easy installation. For further questions, please contact our Technical Sales team.

A setting pistol suitable for your application is supplied at time of delivery.

Standard pistol

Total length: 447 mm (+ SL nose)

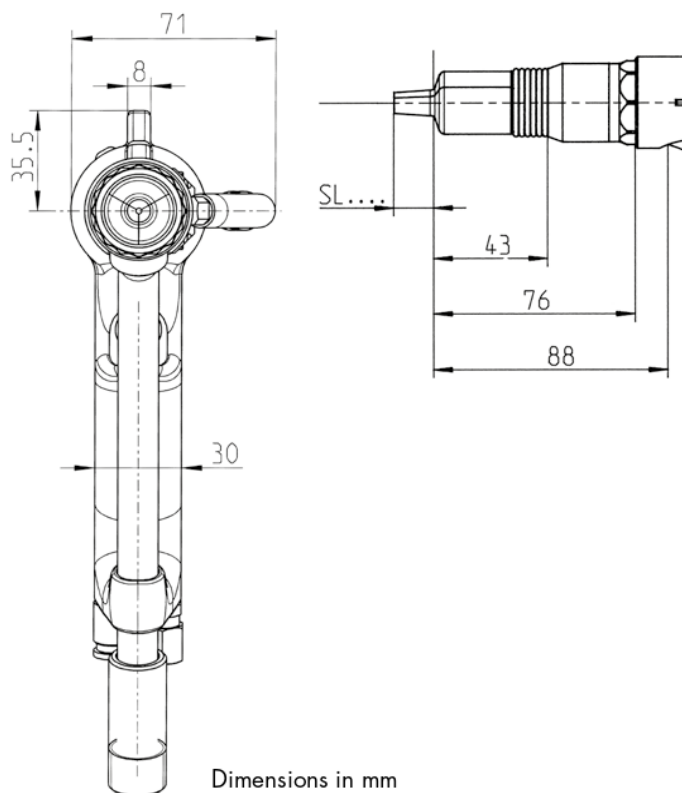

The standard pistol is primarily used for manual operator-controlled use.

Advantages

- Can be used for vertical and horizontal riveting
- Inexpensive variant
- On request, it can be fitted with an extra handle to improve ergonomics, in particular for applications involving vertical riveting

and GAV 8000 electronic

Overhead pistol

Total length: 447 mm (+ SL nose)

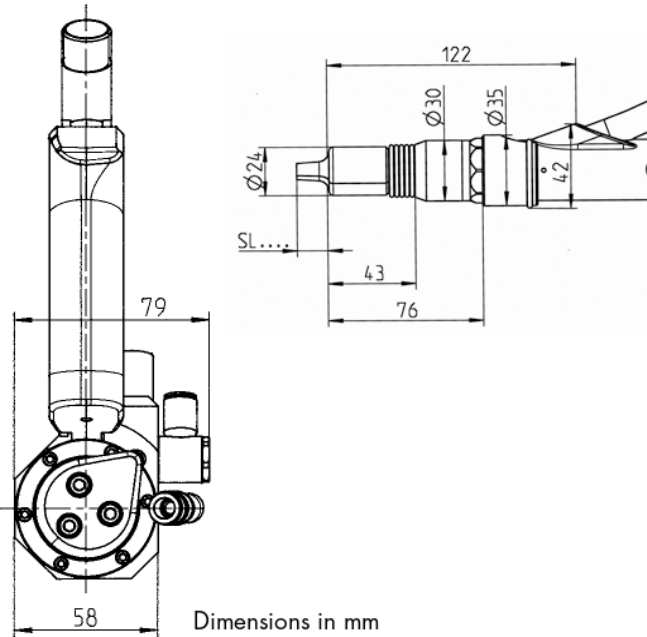

The overhead pistol can be used everywhere where the hose package is cumbersome or where it could come into contact with sensitive surfaces.

Advantage

- Available with contact pressure monitoring

Robotic pistol

Total length: 441 mm (+ SL nose)

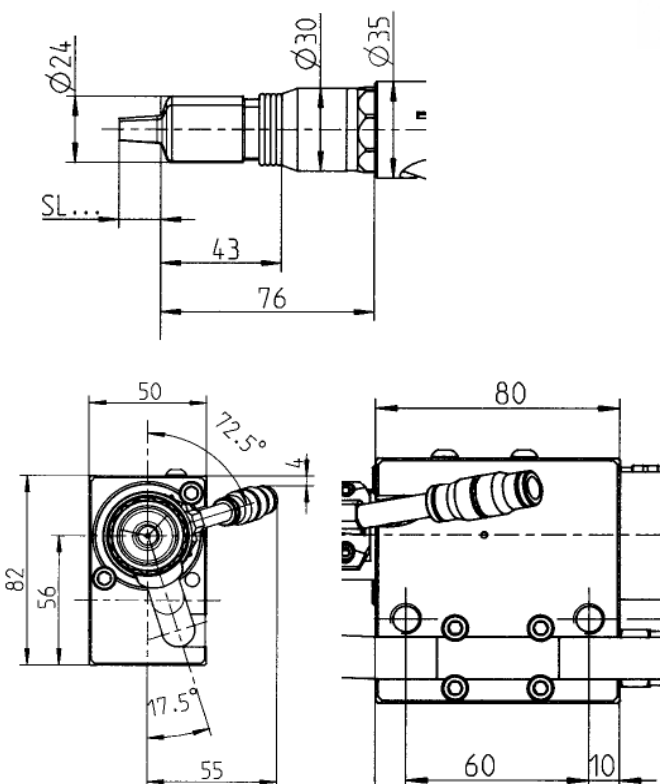

The robotic pistol has been developed primarily for use in fully automatic production applications/system (linear units/robots).

Advantages

- Ideal for integration in a production system
- On request, it can also be fitted with an extra handle (with trigger button) for vertical riveting so that it can be used manually

Dimensions in mm

Accessories for GAV 8000 (both versions)

Individual system configuration for each application case

Interface for connection to external control

The new GESIPA® interface developed by GESIPA® is based on an embedded PC system and provides 24 digital in and out control system ports, Ethernet connection via a RJ45 connector as well as status LEDs. Connection ports for a protocol converter supporting all common bus systems and for external storage media as well as a USB port for fast data transfer complete the features of the new interface. In addition, the GESIPA® interface has a process database for storing 250,000 of the most current process data (date, time, rivet position, process curve, analysis, etc.). Of course, the interface is backward compatible with its predecessor models.



Interface

Part no. 145 6927

Electrical foot pedal

The electrical foot pedal is a good solution wherever applications require both hands to affix the parts that need to be riveted.



Special length tube packages

A larger working radius can be achieved, e.g. for use on fully automatic production lines, by using packages of special hose lengths. These are available in various dimensions between 3.75 m and 5.0 m to meet the requirements of the various applications.

GAV carriage

The trolley that has been specially designed for the GAV enables it to be mobile thereby allowing the workplace to be changed quickly and easily.

Maintenance agreement and training

Ask us about our servicing and maintenance agreements. We can also provide training for your operating, servicing and maintenance personnel when you purchase a GESIPA® blind rivet processing system or at a later date.

Comparison of GAV 8000 eco and GAV 8000 electronic

Properties	GAV 8000 eco	GAV 8000 electronic
Range of possible sizes 2.4 mm - 6.4 mm (Alu)	x	x
Up to 40 rivet settings per minute	x	x
Independent system operation possible	x	x
PLC control possible	x	x
Intelligent control – excellent process safety	x	x
Setting of all operating parameters via the display	x	x
Customer-specific software modification	x	x
Maintenance display	x	x
Process monitoring		x
Process parameter memory for up to 9.999 different parts		x
Online transfer of the process data		x
The last 2 million rivet processes are saved in the device		x

The practical modular principle

The practical modular principle guarantees efficiency and quality

Individual conception for efficiency and flexibility

GESIPA®'s fully-automatic blind rivet processing systems are constructed to meet the customer's special production environment. All factors, such as workplace design, production Type, application, securing of flawless work processes, integration into the sequential organisation and also process documentation for safety-relevant parts, are taken into consideration.

GAV are therefore available with various pistol models, hose length packages, special accessories for various rivet dimensions and production requirements. This results in a large variety of models and a high level of efficiency thanks to the solutions that are adapted to meet requirements.

The GAV can be integrated into the system or operated independently. If the application changes, the system can be quickly and easily adapted to the new environment.

3

GAV – Use in robot applications

Use by industry in robot-controlled applications

Both versions of the GAV 8000 can be integrated into robot systems. Industrial robots are used almost everywhere in the production environment. They can be programmed to carry out various movements and can therefore be used highly efficiently in combination with the GESIPA® rivet equipment.

With the controlled, fast and secure production processes it is possible to achieve the following benefits by using a fully-automatic GAV combined with a multi-axle robot:

- **First rate precision**
- **High efficiency**
- **Short cycle times**
- **High flexibility**



Blind rivet function documentation and setting process monitoring

The integrated GESIPA® quality management system guarantees precision and accuracy right from the very first production step through to the processed blind rivet.

The combination of the use of function-documented blind rivets and the use of the setting process monitoring function of the GAV 8000 electronic guarantees process-secure connections.

The quality management system comprises of three areas:

- Dimensional review
- Function test
- Setting process monitoring

The dimensional review and the function test are carried out at GESIPA®, whilst the setting process is monitored during the riveting process at the customer's premises.

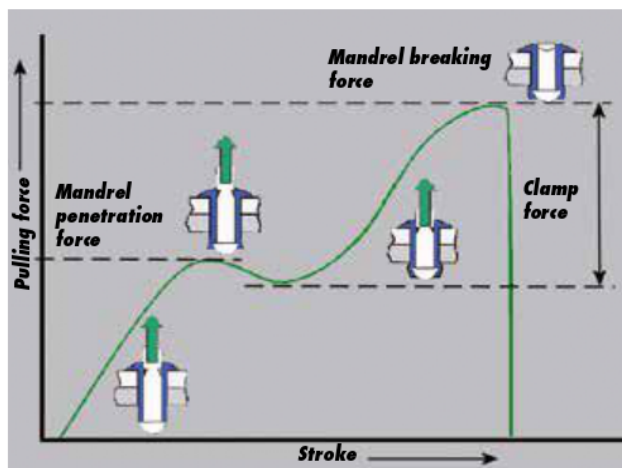

(1)

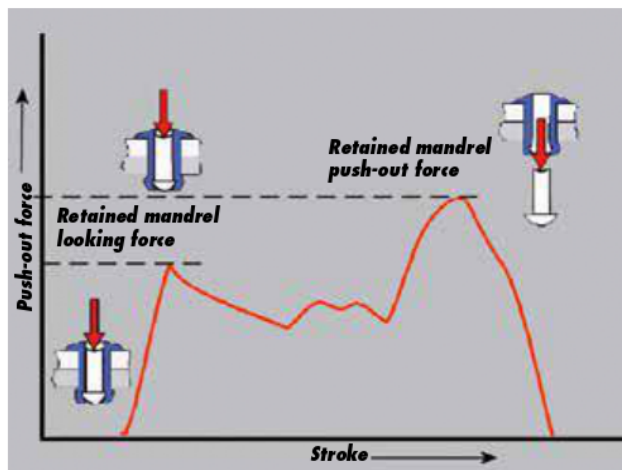

(2)

Function documentation / Setting curve (1)

In addition to other parameters, the setting curve is measured using calibrated testing equipment for every batch of application-specific blind riveting. The measuring results of the shaft deformation, slip-in behaviour, mandrel break load and torque are compared to target values to ensure that the blind rivet in the application is deformed as required and creates a secure connection.

Function documentation / Mandrel ejection force (2)

The remaining part of the mandrel enclosed in the set rivet is pressed out with the aid of a needle. The measured force can be used to determine whether the remaining part of the pin is properly locked and will not cause any rattling noises or fall out. The batch is only released if both these values are within tolerances.

Monitored process – Reliable connection

100% inspections of the riveting processes are required for safety-relevant applications for industrial processing of blind rivets. In this case, the fully-automatic rivet device GAV 8000 electronic allows application-compatible efficient solutions ranging from the basic system through to a system with a barcode scanner.

The concept to the integrated setting process monitoring



Display of a GAV 8000 electronic indicating the setting curve as part of the setting process monitoring

The process monitoring system is an integral part of the GAV 8000 electronic.

It offers the following benefits:

- Optimum process security thanks to integrated quality concept
- Blind rivet-specific process monitoring
- System can be operated independently
- No memory-programmable control system (SPS) required to operate the device
- No system calibration required when system is exchanged
- Little installation effort required
- Interfaces to the control integration

Programming the setting process monitoring

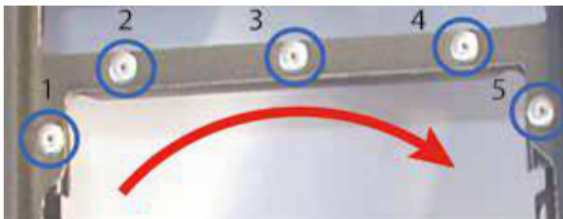

The setting sequence

Step 1:

Setting up blind rivet position-specific profiles

Recording and archiving of the relevant process parameters to create a blind rivet connection with reference process curves after defining the analysis window

Step 2:

Generation of part-specific profile lists

Summary of the profile in the setting sequence as a control file for the process sequence and process assessment

Step 3:

Operating the device

Online analysis and saving of the setting process data with process interruption if deviations are detected

GAV HF

Fully-automatic blind rivet system for very strong blind rivets

Working range

- Blind rivet sizes from 4.8 mm to 8.0 mm Ø all materials
- Rivet body lengths up to 35 mm
- Setting head diameter up to 19 mm
- Mandrel up to 5.5 mm Ø
- Traction power up to 25,000 N at 6 bar air pressure



Size comparison between a possible blind rivet of the GAV HF, a GESIPA®-PolyGrip® and an 1 Euro coin.



Advantages

- Conveyor pot filling level display
- Operating pressure: 5 bar
- Vibration-dampened pressure intensifier attachment
- Multiple monitoring of the blind rivet pistol by means of sensors
- Industrial control with an 8" colour display
- Conveyor distances of up to 25 m are possible when used in fully-automatic production systems
- Electronic system controls
- Intuitive menu guidance via navigation and function keys
- Function display
- Maintenance display and simple fault diagnosis
- Customer-specific software modification is possible
- Ideal for applications that do not require any process monitoring
- Rivet mandrels are disposed of via a vacuum system
- Surface contact trigger available as an optional extra
- Can be integrated into the system or operated independently
- Interface for external memory-programmable control system (SPS) can be realised via the GESIPA®-Interface

Advice, price and delivery time on request

Accessories for GAV HF

The accessories for GAV HF allow an individual system configuration for each different application case

Electrical foot pedal

The foot pedal is a practical solution wherever applications require both hands to affix the parts that need to be riveted.

Surface contact monitoring with dual-hand operation

This special Type of surface contact monitoring guarantees the manipulation-proof process-secure joining of parts. In applications that are relevant for safety, it is often necessary to completely rule out manipulations in the riveting process.

GSM radio modul

In the event of any deviations to the target status e.g. nearly empty feed unit, the GSM radio module (GSM = Global System for Mobile Communications) reports this to a mobile telephone or a process control centre via a call or an SMS. This allows short response times.

Electronic key system and safety switch

An electronic key system and a safety switch guarantee safe access control for at least two user groups and lock the covering hood to prevent unauthorised access to the components in the supply unit.

Interface for connection to external control

The new GESIPA® interface developed by GESIPA® is based on an embedded PC system and provides 24 digital in and out control system ports, Ethernet connection via a RJ45 connector as well as status LEDs. Connection ports for a protocol converter supporting all common bus systems and for external storage media as well as a USB port for fast data transfer complete the features of the new interface. In addition, the GESIPA® interface has a process database for storing 250,000 of the most current process data (date, time, rivet position, process curve, analysis, etc.). Of course, the interface is backward compatible with its predecessor models.



Foot pedal

Special length tube packages

A larger working radius can be achieved, e.g. for use on fully automatic production lines, by using packages of special hose lengths. These are available in various dimensions up to around 25 m to meet the requirements of the various applications.

Operatingstatus display

The signal lamps attached to the device in the colours red, green and white indicate the operating status of the system. An empty rivet tank, any deviations from the target operating status etc. are indicated immediately.

GESIPA®-Interface



Part no. 144 5980

Signal lamps indicate the operating status



GESIPA® assembly cell

The new GESIPA® assembly cell guarantees optimum, precise handling with a wide range of GESIPA® processing devices and a workspace tailored perfectly to the customer's requirements.

The desk is adapted individually to customer requirements and designed ergonomically (e.g. adjustable height). Everything – be it the desk, work piece socket, compressed air supply, electrical supply or processing tools – comes from one source, with process monitoring on request.

The optimised work piece socket allows the desk to be converted for different products and processing tools easily, saving costs.

The GESIPA® assembly cell is produced from high quality materials and components. Needless to say, you also have the option of transferring system components already used at your company.

Advantages

- Ergonomic working
- Individually adjustable
- Existing work tools can be integrated
- Easy and time-saving conversion for other products from your portfolio
- Setting process monitoring possible

More information on the individually adjusted assembly cell on request.



Example:
Can be individually adjusted for each customer



The individual work station

Specifics



Operating status display

The signal light installed on the desk uses different colours to show the process status.



Counting device

The counting device registers and counts the torn off residual rivet mandrels.



GESIPA® setting tool

The setting tool is completely integrated in the assembly cell.



Individual work piece carrier

The optimised work piece carrier allows the desk to be converted for different products and processing tools easily, saving costs.



Foot pedal

The foot pedal allows you to use both hands to join individual parts and fasten the components to be riveted in place.

Speed Rivet Technology

- » trust
- » move
- » know
- » understand
- » create

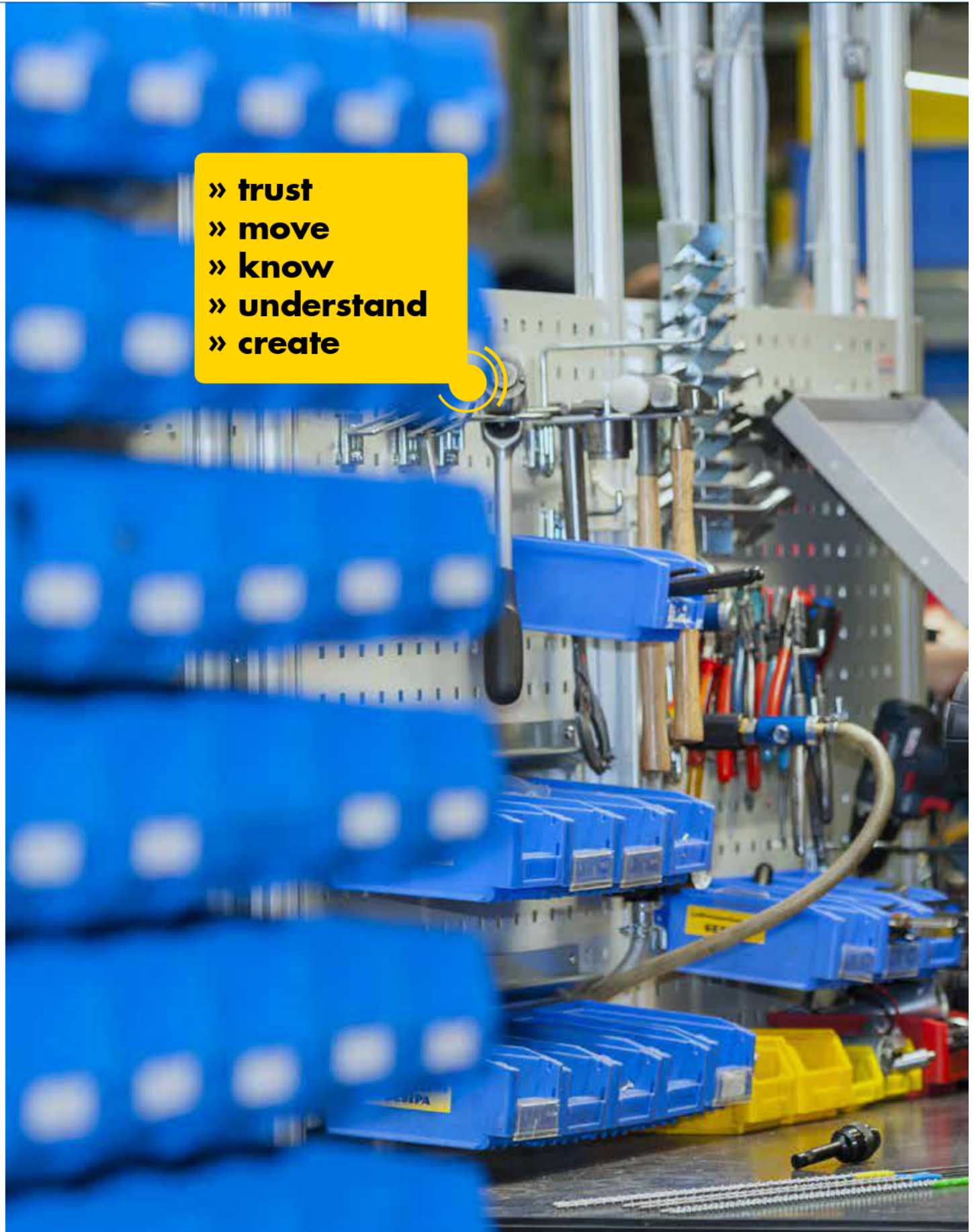



GESIPA® Speed Rivet Technology

Up to 60 rivets per minute! – Endorsed by major customers! GESIPA® speed rivets are a cost-effective alternative to automation



Fasteners and setting tools from a single source

Speed rivet technology is a **joining method** that requires **access from only one side** and which enables **fast cycle times** thanks to the **preloaded rivets** and automatic feed. After the setting operation the tool automatically makes the next rivet available. This technology is predominantly used in the industry, electronics, lighting, lightweight construction and aviation. Simple **one-hand operation** ensures rapid hole location and subsequent implementation of the joining process.

A particular feature of the **GESIPA® Speed Rivet Technology** is that the **speed rivet is immediately ready for use**. The **disposable mandrel** with captive speed rivets ensures the speed rivets are immediately ready for use, thus guaranteeing fast loading and fast magazine change (the joining elements do not need to be inserted individually by hand in the processing tool).

The relevant application of the rivet magazine is indicated by a distinct colour marking. With GESIPA® Speed Rivet Technology no spent mandrel remains in the joint after riveting.

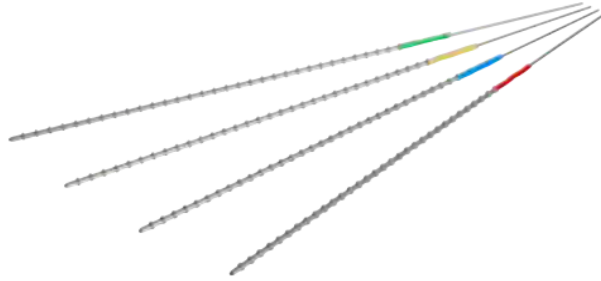

Speed riveting technology completes GESIPA Blindniet-technik GmbH's product portfolio. The new speed rivet setting tools by GESIPA® are the product of decades of expertise and the unbeatable advantages of the well-known, tried-and-tested TAURUS® series. Our engineers' main objectives in its development were for the Speed Rivet tools to be safe, quick and reliable. The very light and ergonomically shaped device will set new standards

The setting process

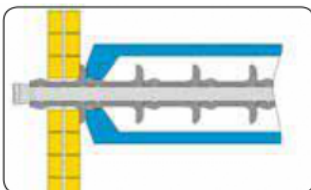

1 The speed rivet is introduced into the joint.

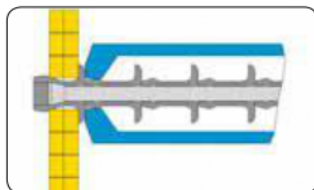

2 The mandrel is pulled through the rivet thus joining the materials.

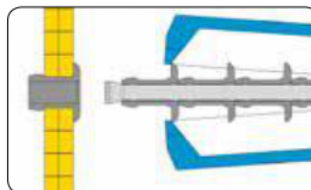

3 The next speed rivet is ready automatically.

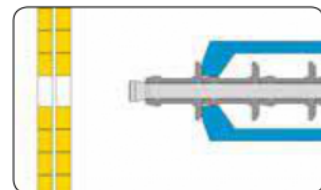

4 The setting process can now be repeated.

Advantages of the GESIPA® speed rivet:

- Ready to use rivet magazine
- Extremely fast processing and cycle times
- Quick magazine change
- One-hand operation
- Vibration-proof
- Stable in use
- Reduced parts handling
- Versatile application
- Easy to operate
- Ideal for medium- and high-volume production
- No spent mandrel, therefore:
 - No corrosion
 - No lost mandrels
 - No noise
 - No short-circuits caused by loose parts
- Joining elements cannot drop off during processing
- Low-price alternative to fully automatic systems
- Made in Germany

Overview **GESIPA®** Magazinnietechnik

Speed rivets

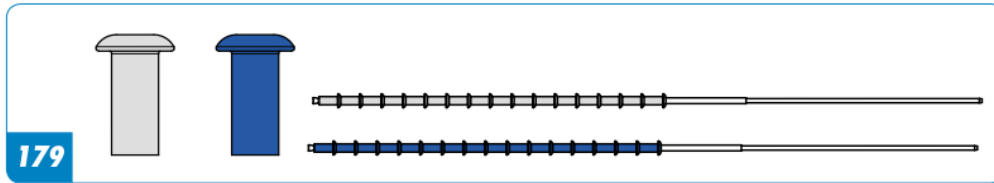

179

G-Speed® alu and steel

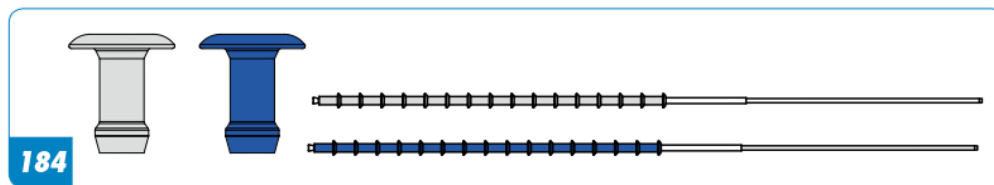

184

Speed Bulb® alu and steel

Speed rivet setting tools



187

TAURUS® 1 Speed Rivet



188

TAURUS® 2 Speed Rivet



189

TAURUS® 1 and 2
Speed Rivet Axial eco

What rivets what?

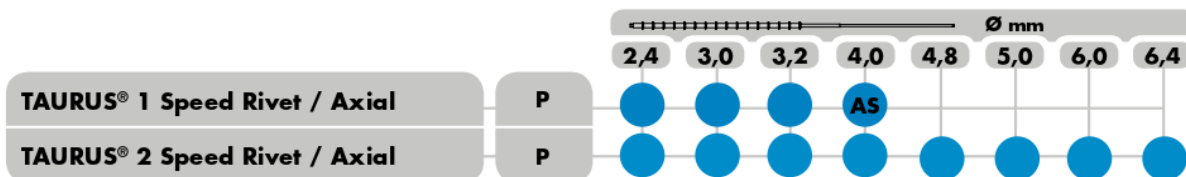

P: Hydro-pneumatic tool

A: Alu/Copper

S: Steel

E: Stainless Steel / Monel

Blue box: All materials(ASE) can be riveted. Where there are exceptions, the letters of the rivetable materials are provided directly in the box.

G-Speed®

G-Speed® the multi-range speed rivet from GESIPA® for a wide range of applications.



Advantages

- **Large grip range**
- Reduced variation
- Optimum hole filling capabilities and bearing stress
- Ideally suited for transferring shear strengths with moderate clamping force
- Ideal for:
 - LED light strips
 - Electronic/pcb assembly
 - Lightweight sheet metal structures
 - PC housings
 - Rating plates
 - Blind holes

Two mandrel lengths are available for the speed rivet:
 S ≈ 485 mm for the standard nosepiece
 L ≈ 510 mm for the long or curved nosepieces

To achieve an optimum riveted joint for different bore diameters, a number of mandrel size groups are available. The application range of each speed rivet is denoted by a clear colour code, ensuring the unequivocal classification of the mandrel size groups.

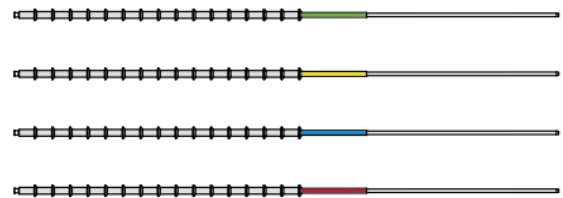

G-Speed®
 The multi-range speed rivet from GESIPA® for a wide range of applications.

Grip range	+ + +
Shear strength	+ +
Tensile strength	+
Pulling strength	+ +

Classification of the mandrel size groups:	Hollow-rivet diameter (mm)		
	3.0	3.2	4.0
	Bore diameter (mm)		
Standard	3.05 - 3.15	3.25 - 3.35	4.05 - 4.15
1st oversize	3.15 - 3.25	3.35 - 3.45	4.15 - 4.25
2nd oversize (on request)	3.25 - 3.35	3.45 - 3.55	4.25 - 4.35
3rd oversize (on request)	3.35 - 3.45	3.55 - 3.65	4.35 - 4.45

G-Speed®

Alu

Dome head

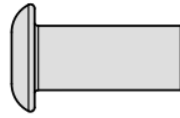

	Rivet body D1 x L mm	Grip range mm	Number of rivets on mandrel ± 1	Quantity per box	Mandrel length for nosepiece	*	*
3.2	3.2 x 4.0	1.0 - 3.0	59	20,000	S (485 mm)	146 3628	146 3636
					L (510 mm)	146 3975	146 3981
	3.2 x 5.5	1.0 - 4.5	46	15,000	S (485 mm)	146 3629	146 3637
					L (510 mm)	146 3979	146 3982
	3.2 x 7.0	1.0 - 6.0	38	12,500	S (485 mm)	146 3630	146 3638
					L (510 mm)	146 4006	146 4011
	3.2 x 8.5	1.0 - 7.5	32	10,000	S (485 mm)	146 3631	146 3639
					L (510 mm)	146 4007	146 4012
4.0	4.0 x 4.0	1.0 - 3.0	59	20,000	L4 (485 mm)	151 9021	151 9125
					L5 (510 mm)	151 9198	151 9302
	4.0 x 5.5	1.0 - 4.5	46	15,000	L4 (485 mm)	151 9023	151 9126
					L5 (510 mm)	151 9199	151 9303
	4.0 x 7.0	1.0 - 6.0	38	12,500	S (485 mm)	151 9025	151 9127
					L (510 mm)	151 9200	151 9305
	4.0 x 8.5	1.0 - 7.5	32	10,000	S (485 mm)	151 9026	151 9128
					L (510 mm)	151 9201	151 9306
4.8	4.8 x 4.0	1.0 - 3.0	56	15,000	L4 (485 mm)	151 9041	151 9133
					L5 (510 mm)	151 9206	151 9360
	4.8 x 5.5	1.0 - 4.5	44	12,500	L4 (485 mm)	151 9042	151 9134
					L5 (510 mm)	151 9207	151 9361
	4.8 x 7.0	1.0 - 6.0	36	10,000	L4 (485 mm)	151 9043	151 9135
					L5 (510 mm)	151 9219	151 9362
	4.8 x 8.5	1.0 - 7.5	31	10,000	L4 (485 mm)	151 9044	151 9136
					L5 (510 mm)	151 9218	151 9363

Alu

Countersunk

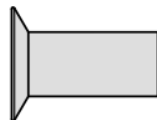

	Rivet body D1 x L mm	Grip range mm	Number of rivets on mandrel ± 1	Quantity per box	Mandrel length for nosepiece	*	*
3.2	3.2 x 4.0	1.0 - 3.0	75	25,000	S (485 mm)	146 3660	146 3668
					L (510 mm)	146 4047	146 4054
	3.2 x 5.5	1.0 - 4.5	55	17,500	S (485 mm)	146 3661	146 3669
					L (510 mm)	146 4048	146 4055
	3.2 x 7.0	1.0 - 6.0	43	15,000	S (485 mm)	146 3662	146 3670
					L (510 mm)	146 4049	146 4056
	3.2 x 8.5	1.0 - 7.5	36	12,500	S (485 mm)	146 3663	146 3671
					L (510 mm)	146 4050	146 4057

* Other oversizes available on request. For details see table on page 179.

G-Speed®

	Rivet body D1 x L mm	Grip range mm	Number of rivets on mandrel ± 1	Quantity per box	Mandrel length for nosepiece	Part no.	Part no.
4.0	4.0 x 4.0	1.0 - 3.0	75	25,000	L4 (485 mm)	151 9027	151 9129
					L5 (510 mm)	151 9202	151 9308
	4.0 x 5.5	1.0 - 4.5	55	17,500	L4 (485 mm)	151 9028	151 9130
					L5 (510 mm)	151 9203	151 9356
	4.0 x 7.0	1.0 - 6.0	43	15,500	S (485 mm)	151 9029	151 9131
					L (510 mm)	151 9204	151 9357
	4.0 x 8.5	1.0 - 7.5	36	12,500	S (485 mm)	151 9030	151 9132
					L (510 mm)	151 9205	151 9359
4.8	4.8 x 4.0	1.0 - 3.0	75	22,500	L4 (485 mm)	151 9046	151 9137
					L5 (510 mm)	151 9217	151 9364
	4.8 x 5.5	1.0 - 4.5	55	17,500	L4 (485 mm)	151 9047	151 9138
					L5 (510 mm)	151 9216	151 9365
	4.8 x 7.0	1.0 - 6.0	43	12,500	L4 (485 mm)	151 9048	151 9139
					L5 (510 mm)	151 9214	151 9366
	4.8 x 8.5	1.0 - 7.5	36	10,000	L4 (485 mm)	151 9050	151 9140
					L5 (510 mm)	151 9213	151 9367

4

Steel Dome head



	Rivet body D1 x L mm	Grip range mm	Number of rivets on mandrel ± 1	Quantity per box	Mandrel length for nosepiece	Part no.	Part no.
3.2	3.2 x 4.0	1.0 - 3.0	59	20,000	L4 (485 mm)	146 4076	146 4084
					L5 (510 mm)	146 4168	146 4176
	3.2 x 5.5	1.0 - 4.5	46	15,000	L4 (485 mm)	146 4077	146 4085
					L5 (510 mm)	146 4169	146 4177
	3.2 x 7.0	1.0 - 6.0	38	12,500	L4 (485 mm)	146 4078	146 4086
					L5 (510 mm)	146 4170	146 4178
	3.2 x 8.5	1.0 - 7.5	32	10,000	L4 (485 mm)	146 4079	146 4087
					L5 (510 mm)	146 4171	146 4179
4.0	4.0 x 4.0	1.0 - 3.0	59	20,000	L4 (485 mm)	151 9059	151 9152
					L5 (510 mm)	151 9260	151 9369
	4.0 x 5.5	1.0 - 4.5	46	15,000	L4 (485 mm)	151 9060	151 9154
					L5 (510 mm)	151 9281	151 9389
	4.0 x 7.0	1.0 - 6.0	38	12,500	L4 (485 mm)	146 4507	146 4505
					L5 (510 mm)	146 4495	146 4493
	4.0 x 8.5	1.0 - 7.5	32	10,000	L4 (485 mm)	146 4506	146 4504
					L5 (510 mm)	146 4494	146 4492

* Other oversizes available on request. For details see table on page 179.

G-Speed®

	Rivet body D1 x L mm	Grip range mm	Number of rivets on mandrel ± 1	Quantity per box	Mandrel length for nosepiece	Part no.	Part no.
4.8	4.8 x 4.0	1.0 - 3.0	56	15,000	L4 (485 mm)	151 9073	151 9157
					L5 (510 mm)	151 9284	151 9441
	4.8 x 5.5	1.0 - 4.5	44	12,500	L4 (485 mm)	151 9078	151 9159
					L5 (510 mm)	151 9285	151 9442
	4.8 x 7.0	1.0 - 6.0	36	10,000	L4 (485 mm)	151 9082	151 9160
					L5 (510 mm)	151 9286	151 9443
4.8 x 8.5	1.0 - 7.5	31	10,000	L4 (485 mm)	151 9109	151 9161	
				L5 (510 mm)	151 9287	151 9444	

Steel Countersunk

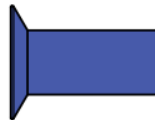

	Rivet body D1 x L mm	Grip range mm	Number of rivets on mandrel ± 1	Quantity per box	Mandrel length for nosepiece	Part no.	Part no.
3.2	3.2 x 4.0	1.0 - 3.0	75	25,000	L4 (485 mm)	146 4136	146 4144
					L5 (510 mm)	146 4200	146 4208
	3.2 x 5.5	1.0 - 4.5	55	20,000	L4 (485 mm)	146 4137	146 4145
					L5 (510 mm)	146 4201	146 4209
	3.2 x 7.0	1.0 - 6.0	43	15,000	L4 (485 mm)	146 4138	146 4146
					L5 (510 mm)	146 4202	146 4210
3.2 x 8.5	1.0 - 7.5	36	12,500	L4 (485 mm)	146 4139	146 4147	
				L5 (510 mm)	146 4203	146 4211	
4.0	4.0 x 4.0	1.0 - 3.0	75	25,000	L4 (485 mm)	151 9071	151 9155
					L5 (510 mm)	151 9282	151 9390
	4.0 x 5.5	1.0 - 4.5	55	17,500	L4 (485 mm)	151 9072	151 9156
					L5 (510 mm)	151 9283	151 9391
	4.0 x 7.0	1.0 - 6.0	43	15,000	L4 (485 mm)	146 4499	146 4498
					L5 (510 mm)	146 4487	146 4486
4.0 x 8.5	1.0 - 7.5	36	12,500	L4 (485 mm)	146 4912	146 4911	
				L5 (510 mm)	146 4910	146 4909	
4.8	4.8 x 4.0	1.0 - 3.0	75	22,500	L4 (485 mm)	151 9121	151 9190
					L5 (510 mm)	151 9288	151 9445
	4.8 x 5.5	1.0 - 4.5	55	17,500	L4 (485 mm)	151 9122	151 9191
					L5 (510 mm)	151 9289	151 9446
	4.8 x 7.0	1.0 - 6.0	43	12,500	L4 (485 mm)	151 9123	151 9194
					L5 (510 mm)	151 9290	151 9447
4.8 x 8.5	1.0 - 7.5	36	10,000	L4 (485 mm)	151 9124	151 9196	
				L5 (510 mm)	151 9301	151 9461	

* Other oversizes available on request. For details see table on page 179.

G-Speed®

G-Speed® is available in a large number of versions
The individual properties are shown in the following table of possible combinations.

Head shape	Material	Rivet body-Ø mm	Rivet body length
Dome head Counter sunk head	Aluminium	3.0 3.2 4.0	2.5
			4.0
			5.5
			7.0
			8.5
	Steel		10.0
			11.5
			13.0
			14.5*
			16.0*

Example: Countersunk head - steel - 3.0 x 10.0 mm

* only at rivet body Ø 4.8 mm

G-Speed® range of application:

Rivet body length	2.5	4.0	5.5	7.0	8.5	10.0	11.5	13.0	14.5	16.0
Grip range mm	- 1.5	1.0 - 3.0	1.0 - 4.5	1.0 - 6.0	1.0 - 7.5	1.0 - 9.0	1.0 - 10.5	1.0 - 12.0	1.0 - 13.5	1.0 - 15.0

Chart shear strength

G-Speed® dome head alu and steel						
Rivet Ø mm	Alu		Steel		Max. height of head mm	Max. head Ø mm
	Shear strength N	(kp)	Shear strength N	(kp)		
3.0	630	(64)	1,060	(108)	1.2	5.5
3.2	900	(92)	1,400	(142)	1.2	5.5
4.0	1,600	(163)	2,400	(245)	1.5	6.5
4.8	2,000	(204)	3,200	(326)	1.5	8.9

G-Speed® countersunk head alu and steel						
Rivet Ø mm	Alu		Steel		Max. height of head mm	Max. head Ø mm
	Shear strength N	(kp)	Shear strength N	(kp)		
3.0	630	(64)	1,060	(108)	1.0	5.5
3.2	900	(92)	1,400	(142)	1.0	5.7
4.0	1,600	(163)	2,400	(245)	1.0	6.7
4.8	2,000	(204)	3,200	(326)	1.4	9.1

* Typical data, measured at the longest rivet body length

Speed Bulb®

The GESIPA® Speed Bulb® is designed for high and dynamic loads



Advantages

- Optimally adapted to specific grip range
- **Distinct bulb formation**
 - High grip force
 - High pulling force
- For higher loads
- Ideally suited for transmitting **shear and tensile forces**
- Ideal for:
 - Higher dynamic loads
 - Sheet metal structures
 - Electrical devices
 - White goods

Two mandrel lengths are available for the speed rivet:
 S ≈ 485 mm for the standard nosepiece
 L ≈ 510 mm for the long or curved nosepieces

To achieve an optimum riveted joint for different bore diameters, a number of mandrel size groups are available. The application range of each speed rivet is denoted by a clear colour code, ensuring the unequivocal classification of the mandrel size groups.



Speed Bulb®
 Specific joining element optimally adapted for higher loads.

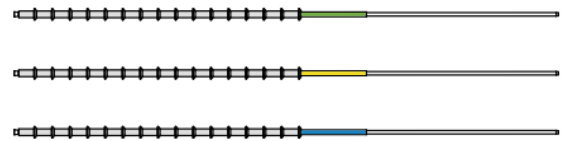

Grip range	++
Shear strength	++
Tensile strength	++
Pulling strength	+++

Classification of the mandrel size groups:	Hollow-rivet diameter (mm)			
	3.0	3.2	4.0	4.8
	Bore diameter (mm)			
Standard	3.05 - 3.15	3.25 - 3.35	4.05 - 4.15	4.85 - 4.95
1st oversize	3.15 - 3.25	3.35 - 3.45	4.15 - 4.25	4.95 - 5.05
2nd oversize (on request)	3.25 - 3.35	3.45 - 3.55	4.25 - 4.35	5.05 - 5.15

Speed Bulb®

Alu Dome head

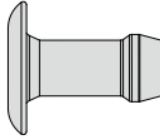

	Rivet body D1 x L mm	Grip range mm	Number of rivets on mandrel ± 1	Quantity per box	Mandrel length for nosepiece	*	*
3.2	3.2 x 4.2	1.0 - 2.3	59	17,500	L4 (485 mm)	151 9636	151 9645
					L5 (510 mm)	151 9646	151 9729
	3.2 x 4.7	1.5 - 2.8	54	17,500	L4 (485 mm)	151 9731	151 9742
					L5 (510 mm)	151 9775	152 0860
	3.2 x 5.2	2.0 - 3.3	49	15,000	L4 (485 mm)	151 9732	151 9743
					L5 (510 mm)	151 9776	152 0833
	3.2 x 6.2	3.0 - 4.3	42	12,500	L4 (485 mm)	151 9733	151 9744
					L5 (510 mm)	151 9777	152 0836
	3.2 x 7.2	4.0 - 5.3	37	12,500	L4 (485 mm)	151 9734	151 9745
					L5 (510 mm)	151 9778	152 0837
	3.2 x 8.2	6.0 - 6.3	33	10,000	L4 (485 mm)	151 9735	151 9750
					L5 (510 mm)	151 9779	152 0838

Steel Dome head

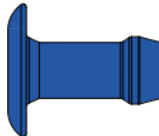

	Rivet body D1 x L mm	Grip range mm	Number of rivets on mandrel ± 1	Quantity per box	Mandrel length for nosepiece	*	*
3.2	3.2 x 4.2	1.0 - 2.3	59	17,500	L4 (485 mm)	151 9644	151 9727
					L5 (510 mm)	151 9728	151 9730
	3.2 x 4.7	1.5 - 2.8	54	17,500	L4 (485 mm)	151 9736	151 9760
					L5 (510 mm)	152 0855	152 0839
	3.2 x 5.2	2.0 - 3.3	49	15,000	L4 (485 mm)	151 9737	151 9771
					L5 (510 mm)	152 0856	152 0840
	3.2 x 6.2	3.0 - 4.3	42	12,500	L4 (485 mm)	151 9738	151 9772
					L5 (510 mm)	152 0857	152 0871
	3.2 x 7.2	4.0 - 5.3	37	12,500	L4 (485 mm)	151 9740	151 9773
					L5 (510 mm)	152 0858	152 0872
	3.2 x 8.2	6.0 - 6.3	33	10,000	L4 (485 mm)	151 9741	151 9774
					L5 (510 mm)	152 0859	152 0873

* Other oversizes available on request. For details see table on page 184.

Speed Bulb®

Speed Bulb® is available in a large number of versions.
The individual properties are shown in the following table of possible combinations.

Head shape	Material	Rivet body-Ø mm	Rivet body length
Dome head	Alu Stahl	3.2	3.7
			4.2
			4.7
			5.2
			6.2
			7.2
			8.2
			9.2
			10.2
			11.2

Example: Dome head - Steel - 3.2 x 10.2 mm

Speed Bulb® range of application:

Rivet body length	3.7	4.2	4.7	5.2	6.2	7.2	8.2	9.2	10.2	11.2
Grip range mm	0.5 - 1.8	1.0 - 2.3	1.5 - 2.8	2.0 - 3.3	3.0 - 4.3	4.0 - 5.3	5.0 - 6.3	6.0 - 7.3	7.0 - 8.3	8.0 - 9.3

Chart shear and tensile strength*

Speed Bulb® dome head alu				
Rivet Ø mm	Shear strength N (kp)	Zugkraft N (kp)	Max. height of head mm	Max. head Ø mm
3.2	700 (71)	1,300 (132)	1.0	6.6

Speed Bulb® dome head steel				
Rivet Ø mm	Shear strength N (kp)	Tensile strength N (kp)	Max. height of head mm	Max. head Ø mm
3.2	1,100 (112)	1,800 (183)	1.0	6.6

* Typical data, measured at the longest rivet body length

TAURUS® 1 Speed Rivet

The hydro-pneumatic-magazine setting tool with quick setting process and fast rates!

Working range

The rivet setting tool is designed for setting standard speed rivets from 2.4 - 4.8 mm Ø of all materials, as well as up to 4 mm Ø in stainless steel.

With silencer

Part no. 145 7684

Technical data

Traction power:	3,500 N at 6 bar
Stroke:	26 mm
Operating pressure:	5-7 bar
Air hose connection:	6 mm Ø (1/4")
Weight:	1.8 kg

Equipment

Tag on device head
1 hydraulic oil bottle 100 ml
1 oil refill can
1 oil press
Operating instructions with spare parts list

Advantages

- Quick setting process, fast rates
- Safe working through disposable mandrel and optional automatic switchoff
- Ergonomic handling for fatigue-free work
- Light and compact design
- Modular construction based on the TAURUS® design
- Softgrip
- Tool-free conversion (spreader nosepiece and spring)

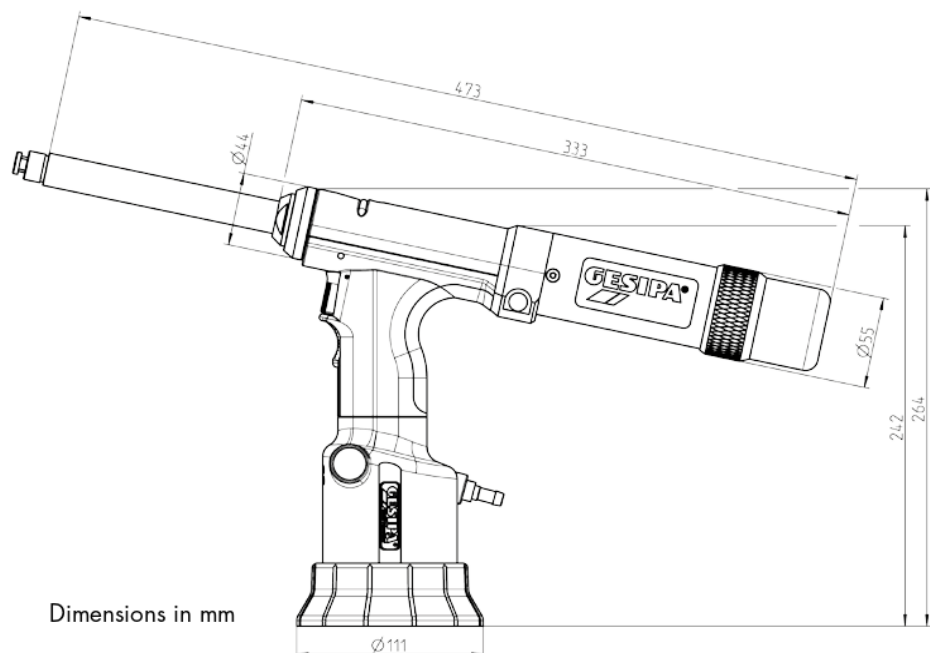

Dimensions in mm



TAURUS® 2 Speed Rivet

The hydro-pneumatic-magazine setting tool with quick setting process and fast rates!

Part no. 145 7833

Working range

The rivet setting tool is designed for setting standard speed rivets from 2.4 - 6.4 mm Ø of all materials.

Technical data

Traction power:	6,500 N at 6 bar
Stroke:	30 mm
Operating pressure:	5-7 bar
Air hose connection:	6 mm Ø (1/4")
Weight:	2.0 kg



Standard tool comes without nosepiece

Equipment

Tag on device head
1 hydraulic oil bottle 100 ml
1 oil refill can
1 oil press
Operating instructions with spare parts list

Advantages

- Quick setting process, fast rates
- Safe working through disposable mandrel and optional automatic switchoff
- Ergonomic handling for fatigue-free work
- Light and compact design
- Modular construction based on the TAURUS® design
- Softgrip
- Tool-free conversion (spreader nosepiece and spring)

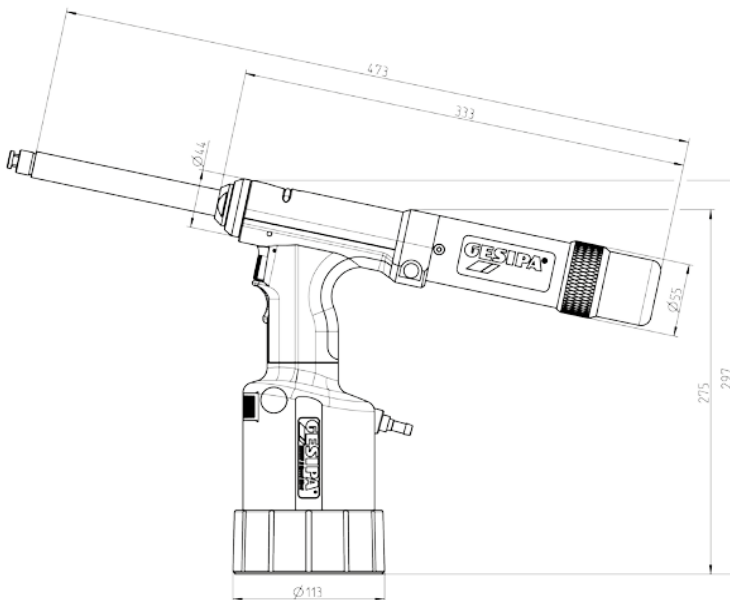

Dimensions in mm

TAURUS® 1 Speed Rivet Axial eco

Axial version of the speed riveting setting tool for special applications

Part no. 145 7692

Working range

The rivet setting tool is designed for setting standard speed rivets from 2.4 - 4.8 mm Ø of all materials, as well as up to 4 mm Ø in stainless steel.

Technical data

Traction power:	3,500 N at 6 bar
Stroke:	26 mm
Operating pressure:	5-7 bar
Air hose connection:	6 mm Ø (1/4")
Weight:	3.0 kg

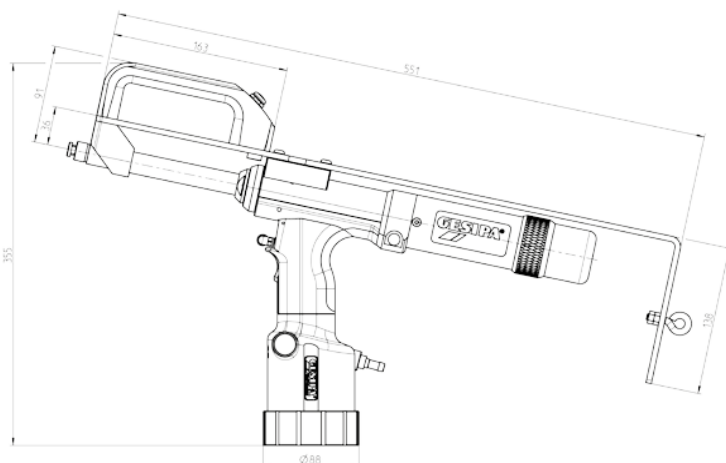

Dimensions in mm



Standard tool comes without nosepiece

Equipment

- 1 hydraulic oil bottle 100 ml
- 1 oil refill can
- 1 oil press
- Operating instructions with spare parts list

Advantages

- Also perfectly designed for fixed installation in production lines or semi-automatic workstations
- Very practical for processing blind rivets in positions that require a vertical rivet setting process
- Can be suspended on a balancer
- Quick setting process, fast rates
- Safe working through disposable mandrel and optional automatic switchoff
- Ergonomic handling for fatigue-free work
- Light and compact design
- Modular construction based on the TAURUS® design
- Softgrip
- Tool-free conversion (spreader nosepiece and spring)

TAURUS® 2 Speed Rivet Axial eco

Axial version of the speed riveting setting tool for special applications

Part no. 145 0931

Working range

The rivet setting tool is designed for setting standard speed rivets from 2.4 - 6 mm Ø of all materials.

Technical data

Traction power:	6,500 N at 6 bar
Stroke:	30 mm
Operating pressure:	5-7 bar
Air hose connection:	6 mm Ø (1/4")
Weight:	3.3 kg

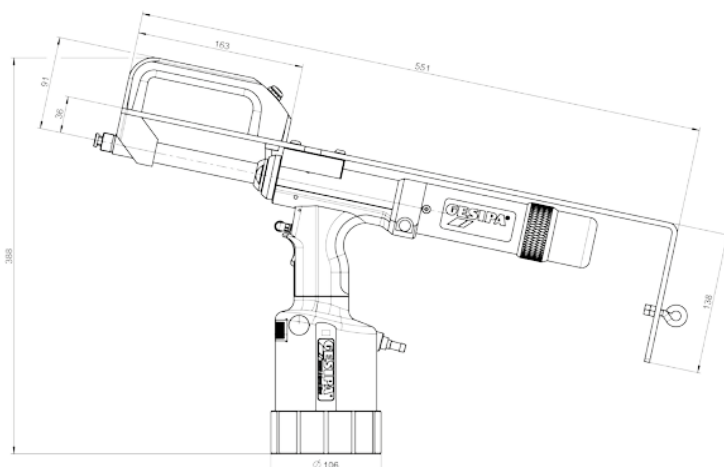

Dimensions in mm



Standard tool comes without nosepiece

Further info



Page 14

Equipment

1 hydraulic oil bottle 100 ml
1 oil refill can
1 oil press
Operating instructions with spare parts list

Advantages

- Also perfectly designed for fixed installation in production lines or semi-automatic workstations
- Very practical for processing blind rivets in positions that require a vertical rivet setting process
- Can be suspended on a balancer
- Quick setting process, fast rates
- Safe working through disposable mandrel and optional automatic switchoff
- Ergonomic handling for fatigue-free work
- Light and compact design
- Modular construction based on the TAURUS® design
- Softgrip
- Tool-free conversion (spreader nosepiece and spring)

Accessories – Speed rivet technology

The different nosepieces

- **Standard:** For easy to access riveting points.
- **Standard pointed:** For countersunk head rivets.
- **Extended and extended bent:** For difficult to access riveting points.
- **With opening mechanism:** Makes it easier to open the nosepiece so that speed rivets can be changed more conveniently and quickly.



Spreader nosepiece without opening mechanism

	Rivet Ø	Part no.	Ø d (mm)	Ø D (mm)	L1 (mm)	L2 (mm)
Standard	3.2	145 7753	6	10.5	31	64
	4.0	145 7754	7.5	12		
	4.8	145 7755	9	14		
Extended	3.2	145 7756	6	10.5	57	90
	4.0	145 7757	7.5	12		
	4.8	145 7758	9	14		
Standard pointed	3.2	145 0900	6	10.5	31	64
	4.0	145 0901	7.5	12		
	4.8	145 0902	9	14		
Extended bent	3.2	145 0903	6	10.5	55	88
	4.0	145 0904	7.5	12	55.5	88.5
	4.8	145 0905	9	14	56	89

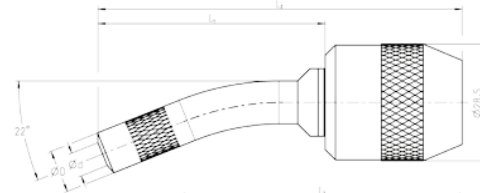
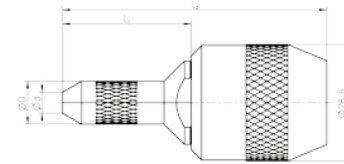
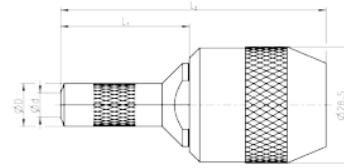

Spreader nosepiece with opening mechanism

	Rivet Ø	Part no.	Ø d (mm)	Ø D (mm)	L1 (mm)	L2 (mm)
Standard	3.2	145 0906	6	10.5	31	67
	4.0	145 0907	7.5	12		
	4.8	145 0908	9	14		
Extended	3.2	145 0909	6	10.5	57	92
	4.0	145 0910	7.5	12		
	4.8	145 0911	9	14		
Standard pointed	3.2	145 0912	6	10.5	31	67
	4.0	145 0913	7.5	12		
	4.8	145 0914	9	14		
Extended bent	3.2	145 0915	6	10.5	55	91
	4.0	145 0916	7.5	12	56	
	4.8	145 0917	9	14	56	

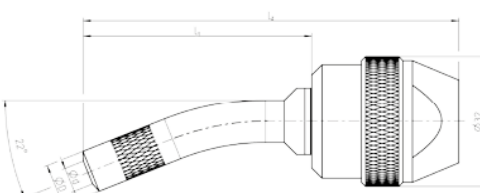
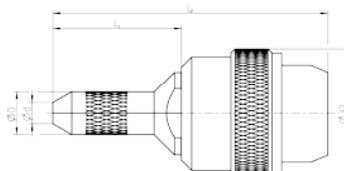
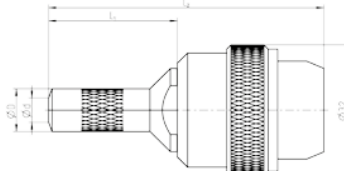

Dimensions in mm

Mandrel spring

	Rivet Ø	Part no.
Standard	3.2	145 7759
	4.0	145 7761
	4.8	145 7763
Extended	3.2	145 7760
	4.0	145 7762
	4.8	145 7764

- **Standard:** For standard spreader nosepiece with or without opening mechanism.
- **Extended:** For extended spreader nosepiece with or without opening mechanism.



Lockbolt setting tools



192



193

PowerBird® SRB 4.8



194

PowerBird® SRB 6.4



195

TAURUS® 3 SRB



196

TAURUS® 4 SRB



197

TAURUS® 4 SRB with angle head 90° compact

Innovative, strong and reliable – Pneumatic-hydraulic lockbolt setting tools ensure that connections last long and are free from vibration.

Lockbolts are used where there are particularly high requirements regarding the durability and vibration safety of the connection. The connection requires the components of the lockbolt to be accessible from two sides. Because the locking ring moulds into the retaining grooves during the setting process, the connection is extremely durable and secure against coming loose on its own.

The GESIPA® lock bolt setting devices in the TAURUS® and Bird® series have been developed using a modular concept and are an ideal composition of experience and consistent further development by our experienced engineers. The lockbolt setting devices guarantee high-quality setting processes and therefore long-lasting and permanently tight connections. In the truck & trailer field in particular, GESIPA® devices ensure fast, trouble-free working processes.



Fastening material by means of lockbolts

With standard lockbolts, the setting process itself is very similar to the blind riveting process.

1. The pin is positioned on one side and the collar on the other side of the materials to be joined.
2. The setting tool grasps the pin while pushing itself against the collar.
3. By pulling the pin the application materials are pressed together and the collar is forced into the grooves of the pin.
4. The joining process is finished once the setting tool hits the joint's surface and the pin breaks off at the predetermined fracture point because of the increasing tensile strength.

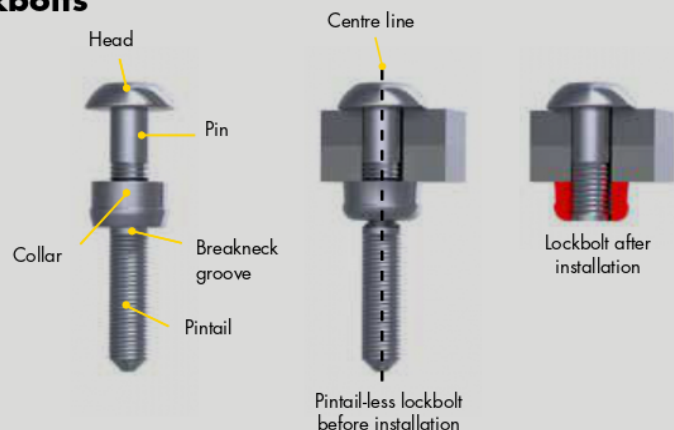

PowerBird® SRB 4.8

Working range

4.8 lockbolts C6L and Magna-Grip®

Technical data

Weight (with battery): 2.2 kg with battery
 Drive: 14.4 V
 Traction power: 14,000 N
 Stroke: 20 mm

Advantages

- Battery-operated lock bolt setting device
- Processing anywhere
- Modular structure
- Ergonomic handling

Equipment

Nosepiece in working position
 Swivelling hanger
 Li-Ion power battery 2.6 Ah/14.4 V
 Charger
 Operating manual with spare parts list
 Plastic carrying case

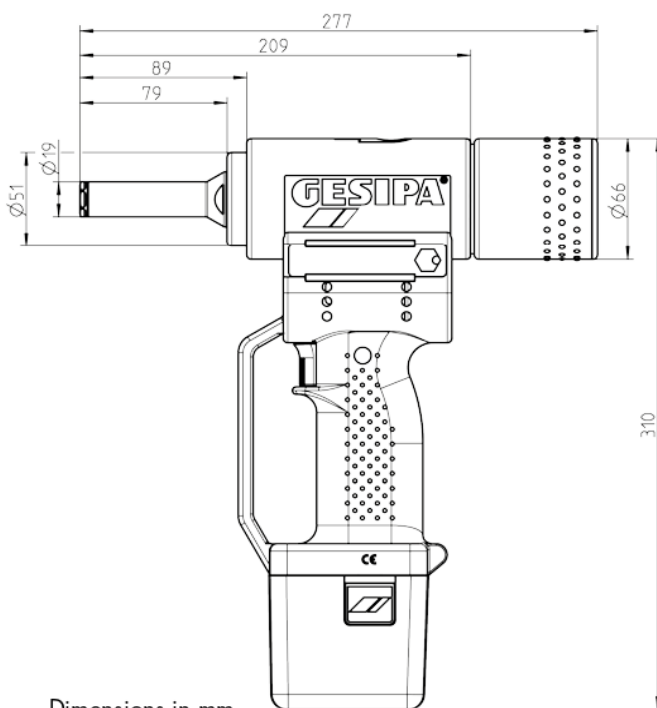

Dimensions in mm



The suitability of nosepiece and fastener needs to be tested by the user and is user's own responsibility!

Jaw mechanism assignment

For lockbolts 4.8 mm Magna-Grip®

Designation	Part no.
Nosepiece	143 4810
Jaw	144 6118
Jaw housing	143 5945

For lockbolts 4.8 mm C6L

Designation	Part no.
Nosepiece	143 4809
Supporting ring	143 5995
Jaw	144 6117
Jaw housing	143 5944

PowerBird® for lock bolts
 4.8 mm (3/16") C6L
Part no. 145 0607

PowerBird® for lock bolts
 4.8 mm (3/16") Magna-Grip®
Part no. 145 0605

*Registered trademark of Alcoa Fastening Systems

PowerBird® SRB 6.4

Working range

6.4 lockbolts MagnaGrip®* and C6L

Technical data

Weight (with battery): 2.4 kg with battery
 Drive: 14.4 V
 Traction Power: 18,000 N
 Stroke: 20 mm

Advantages

- Battery powered lockbolt setting tool
- Processing anywhere
- Light and compact design
- Modular structure
- Ergonomic handling

Equipment

Nosepiece in working position
 Swivelling hanger
 Li-Ion power battery 2.6 Ah/14.4 V
 Charger
 Operating manual with spare parts list
 Plastic carrying case

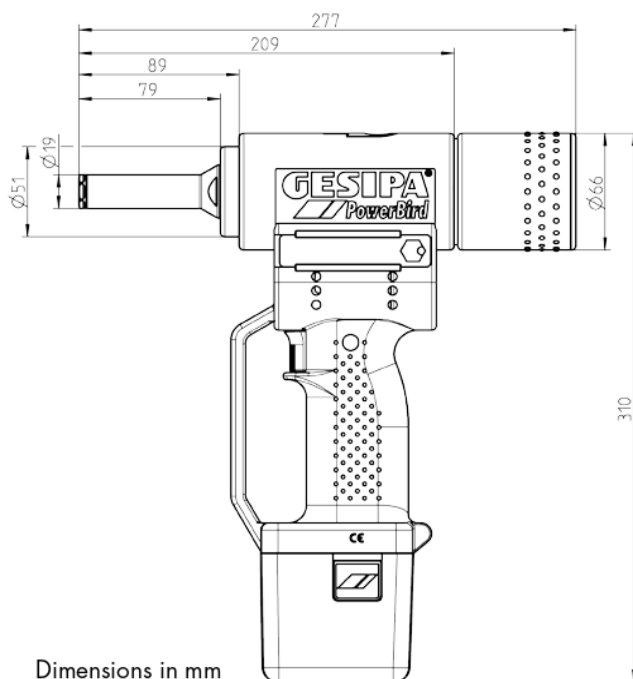

Dimensions in mm



The suitability of nosepiece and fastener needs to be tested by the user and is user's own responsibility!

Jaw mechanism assignment

For lockbolts 4.8 mm Magna-Grip®

Designation	Part no.
Nosepiece	143 5942
Supporting ring	143 5943
Jaw	144 6105
Jaw housing	143 5997

For lockbolts 4.8 mm C6L

Designation	Part no.
Nosepiece	143 5993
Supporting ring	143 5995
Jaw	144 6116
Jaw housing	143 5997

PowerBird® for lockbolts
 6.4 mm (1/4") Magna-Grip®*
Part no. 145 0608

PowerBird® for lockbolts
 6.4 mm (1/4") C6L
Part no. 145 0606

*Registered trademark of Alcoa Fastening Systems

TAURUS® 4 SRB with angle head 90° compact

Working range

6.4 lockbolts MagnaGrip®* and C6L

Technical data

Weight:	2.6 kg
Operating air pressure:	5-7 bar
Air hose connection:	6 mm Ø (1/4")
Air consumption:	approx. 4.8 NL per rivet
Setting force:	23,000 N at 6 bar
Stroke:	19 mm

Advantages

- Hydro-pneumatic lock bolt setting device
- Accessibility in tight working spaces
- Light and compact design
- Modular structure
- Ergonomic handling

Equipment

- Angle head with nosepiece in working position
- Swivelling hanger
- 1 hydraulic oil bottle 100 ml
- 1 oil refill can
- Operating instructions with spare parts list

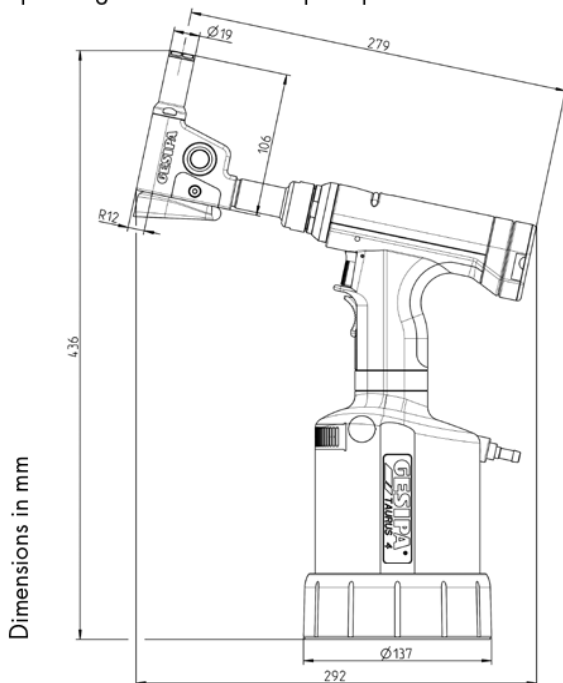

! The suitability of nosepiece and fastener needs to be tested by the user and is user's own responsibility!



Jaw mechanism assignment

For lockbolts 6.4 mm (1/4") Magna-Grip®

Designation	Part no.
Nosepiece	143 5942
Supporting ring	143 5943
Jaw	144 6105
Jaw housing	143 5997

For lockbolts 6.4 mm (1/4") C6L

Designation	Part no.
Nosepiece	143 5993
Supporting ring	143 5995
Jaw	144 6116
Jaw housing	143 5997

TAURUS® 4 for SRB 6.4 mm MagnaGrip®
Part no. 145 7990

TAURUS® 4 for SRB 6.4 mm C6L
Part no. 145 7989

*Registered trademark of Alcoa Fastening Systems

Blind rivet nuts technology

- » **trust**
- » **move**
- » **know**
- » **understand**
- » **create**





GESIPA® blind rivet nuts - general information



Joining element with thread

GESIPA® blind rivet nuts and blind rivet studs are joining elements used to produce load-bearing, high stress threads for non-permanent connections. Blind rivet nuts have an inside thread whereas blind rivet studs have an outside thread (threaded pin). As with blind rivets, two or more components can be joined with both joining elements.

Together with the corresponding processing tools they represent a fast, reliable and cost-effective system for producing high quality, strong thread in thin and soft materials.

GESIPA® production and logistics centres through Europe provide our customers with decisive advantages such as short supply routes and fast response times. Continuous investment in staff qualification and production machines guarantee optimum products. Checks throughout the production process guarantee perfect setting characteristics and safe grip – batch after batch after batch...

Application-optimised joining elements

By manufacturing the joining elements ourselves at the GESIPA® production sites we are able to implement specific customer requirements economically and efficiently. We are the specialists for application-optimised blind rivet nuts and blind rivet studs.

Blind rivet nuts and blind rivet studs are used in the most diverse areas of trade and industry – wherever a strong, non-permanent connection needs to be made. For example:

- Automotive
- White goods
- Heating and air conditioning
- Electronics
- Solar
- Construction
- Food

Perfect interaction

GESIPA® blind rivet nuts and GESIPA® processing tools are perfectly matched. Minimum wear, short processing times and long service life characterise the GESIPA® processing tools, thus making a significant contribution to cost optimisation.

GESIPA® blind rivet nuts - general information

Advantages at a glance

- Easy and quick assembly while the component only needs to be accessed from one side
- Placement of durable threads in thin and soft materials (steel, aluminium, magnesium, plastics etc.)
- No thermal influences on the components and therefore no thermal distortion or surface damage to the surface of the components ⇨ No reworking required
- High degree of flexibility in the product process
- Low investment for assembly equipment
- Suitable for a varied range of applications. Also for hybrid joints and soft materials.
- For producing water and gas-tight joints
- No emission of heat, smoke and welding fumes into the surrounding area and therefore no adverse effects on man and the environment

GESIPA® blind rivet nut – terminology

The **setting head** is the part of the blind rivet nut that rests on the visible surface of the component. The user can choose between the following variants:

- Dome head – for a large contact surface on the component
- Small head – for minimum overlap of the blind rivet nut thus allowing the component to rest almost flat
- Countersunk head – for flat surfaces in countersunk holes

The shank is the part of the blind rivet nut that deforms during the setting procedure and fixes the blind rivet nut in the component. The so-called bulb is formed in this process. The user can choose from the following variants:

- Round
- Knurled
- Polygon (hexagon or square)

The material:

Specific to the application, the customer can use blind rivet nuts made from steel, aluminium or stainless steel.

The thread:

The GESIPA® blind rivet nuts have a metric thread as standard. The steel blind rivet nuts meet the requirements of strength class 8.8. Other dimensions, such as imperial or coarse thread, are available on request.

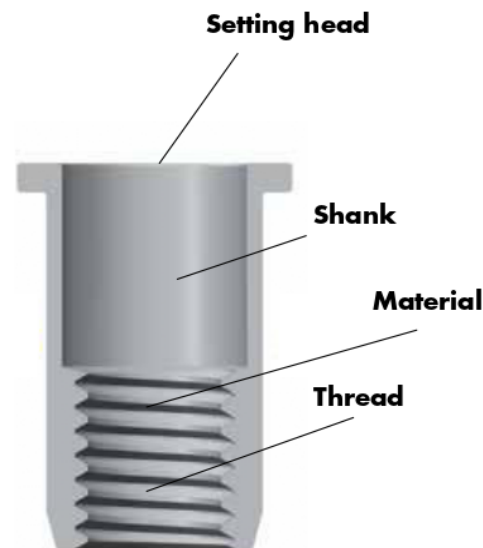

Processing

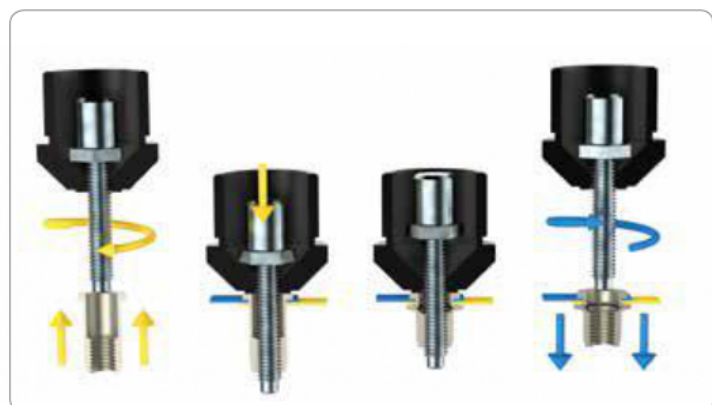

Technical data on GESIPA® blind rivet nuts



Your benefit

The specified forces and torques correspond to calculated values or values determined in tests. They aim to help the user select the suitable fastener. GESIPA® recommends testing the blind rivet nuts in the application. The actual values may differ from the information in the catalogue due to different circumstances.

Please contact our technical team for further help and advice.

The setting process

The picture shows a diagram of the force-stroke curve for setting a blind rivet nut in the lower clamping range. Initially the force rises steeply because the deformation zone of the blind rivet nut is first compressed. Once a certain force is reached, the deformation zone starts to fold outwards. Due to the fact that the resistance of the material is lower during the deformation and creation of the closing head, the force drops slightly.

Force diagram for a setting process

When the closing head meets the backside of the application, the pulling force starts increasing again. To ensure that the blind rivet nut sits tightly on the application material and does not slip when subjected to torque, the closing head must lie completely flat on the joining material (see cross-sections of the blind rivet nuts on the following page). If the setting process is not interrupted, the force will continue to rise until the thread is destroyed.



Technical data on GESIPA® blind rivet nuts

The two charts show the torque curve when screwing differently set blind rivet nuts. The pictures show the corresponding cross section of set blind rivet nuts. The upper picture shows the flat and completely formed closing head in the black frame. In contrast, the setting stroke of the blind rivet nut in the picture below is lower. This means that the closing head is not completely formed. A gap is still visible here in the folded forming zone. The incomplete closing head is framed in red.

In the upper chart, the torque curve increases until the maximum thread load is reached before it fails. In the case of incompletely set blind rivet nuts, the torque curve runs as shown in the lower chart.

The torque only increase briefly and then runs at almost the same level for some time. The screw is screwed in further, however the preload force does not increase. Almost all the force resulting from the torque is used to form the final closing head. The torque only increases again once the forming zone is completely folded as shown in the upper picture.

In an angle-controlled screwing process, the process is always stopped after the pre-set rotation angle. If the blind rivet is not set properly, the screwing process is interrupted, again after the same rotation angle. However in this case, the required clamping force has not yet been reached.

Torque-angle of rotation diagram with the stroke set correctly

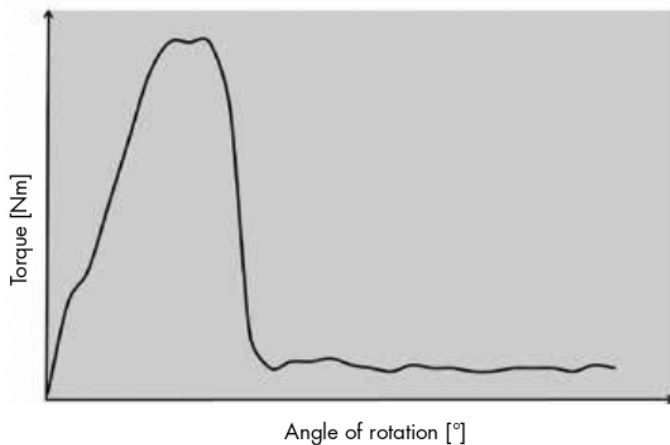

Torque-angle of rotation diagram with the stroke set correctly

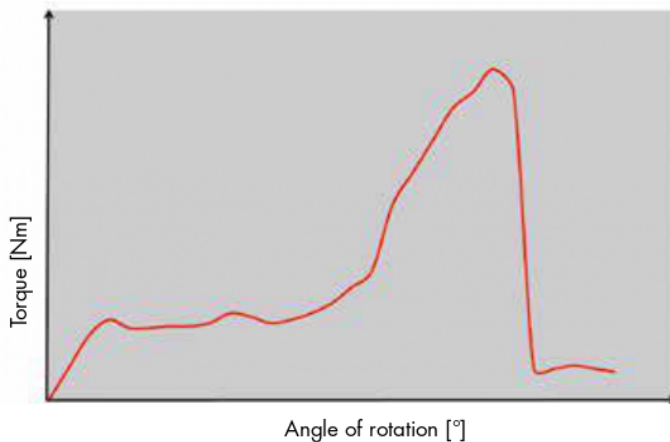

Technical data on GESIPA® blind rivet nuts

The tightening torque (Nm) and (lb-ft)

	Alu		Steel		Stainless steel A2 / A4 / Monel	
	Nm	(lb-ft)	Nm	(lb-ft)	Nm	(lb-ft)
M4	2.5	1.8	3.0	2.2	5.5	4.1
M5	5.0	3,7	8.0	5.9	14.0	10.3
M6	9.5	7.0	12.0	8.9	27.0	19.9
M8	17.5	12.9	30.0	22.1	40.0	29.5
M10	28.0	20.7	38.0	28.0	-	-

The tightening torque [(Nm) or (lb-ft)] specifies the maximum torque with which the screw can be tightened.

The overtorque is the fail limit of the thread. This is higher than the maximum recommended tightening torque and primarily depends on the Type of thread and the friction partner. Reduced friction surfaces, borehole tolerances or lower friction coefficients μ , can greatly reduce the overtorque so that the thread of the blind rivet nut fails even before the specified value is reached.

For testing, GESIPA® uses screws of the strength class 10.9 or higher that are free of all lubricants. A hardened washer is used as the clamping part.

The test is carried out in the lower and the upper clamping range, where the blind rivet nuts are loaded with the specified torque. Then the screw is screwed out again. The thread must still turn smoothly in order to pass the test. Then the blind rivet nut is loaded again up to the overtorque.

Schematic layout for the torque test

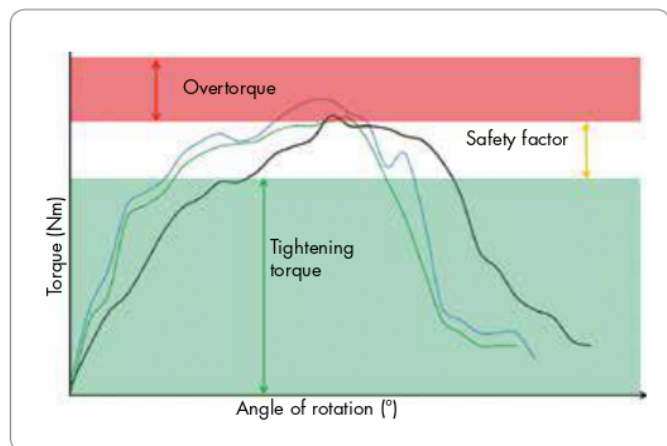

Torque-angle of rotation diagram

The diagram above shows examples of three torque rotational angle curves. The highest torque value that is reached when screwing a screw into a blind rivet is the overtorque. This is the point where the blind rivet nut will fail. All values in the green range can be selected for the torque. The range between the tightening torque and the overtorque is the safety margin.



Technical data on GESIPA® blind rivet nuts

Schematic layout for the thread tear-out test

The maximum bearable axial load on the thread is the thread breaking force [(N) and (kp)]. GESIPA® uses screws of the strength class 10.9 or higher that are free of all lubricants for the test. The test takes place in the lower and upper clamping range.

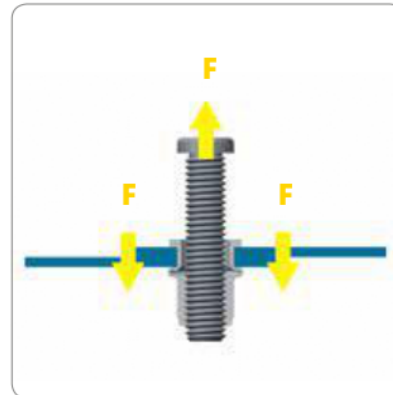

Thread breaking force (N) and (kp)

	alu		steel		stainless steel A2 / A4 / Monel®	
	N	(kp)	N	(kp)	N	(kp)
M4	4,800	489	8,000	815	10,000	1,019
M5	5,700	581	11,500	1,172	15,000	1,529
M6	9,500	968	18,000	1,836	> 25,000	2,548
M8	13,000	1,325	28,000	2,853	> 30,000	3,057
M10	14,000	1,427	30,000	3,057	-	-

Shear strength (N) and (kp)

	alu		steel		stainless steel A2 / A4 / Monel®	
	N	(kp)	N	(kp)	N	(kp)
M4	1,000	102	1,500	153	2,250	229
M5	1,400	143	2,200	224	3,200	326
M6	2,200	224	3,900	397	5,750	586
M8	3,000	306	5,100	520	7,600	774
M10	3,600	367	6,000	611	-	-

Schematic layout for the shear strength test

The shear strength [(N) and (kp)] states the minimum transverse force up to which the set blind rivet can be loaded before it fails. The load is exerted as a single shear and without a screw at a clamping length of 3.0 mm.

The stated values only apply to round flat head blind rivet nuts. The values for other models depend on the material of the application and the head shape. These can be determined on request.



Blind rivet nuts range



- » high quality
- » tested
- » safe

Overview of the GESIPA® blind rivet nuts range

209

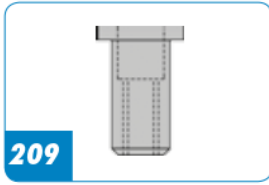

Aluminium

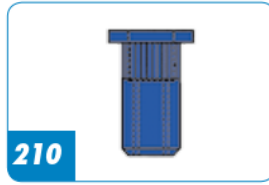

Steel splined



Steel square bodied



Steel half hexagonal

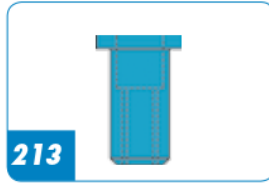

Stainless steel A2



Stainless steel A2 half hexagonal



Stainless steel A4



Stainless steel A4 half hexagonal



Monel®

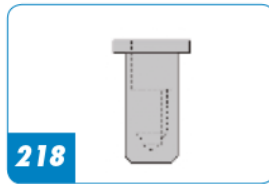

Alu closed end (CAP®)



Steel closed end (CAP®)

220

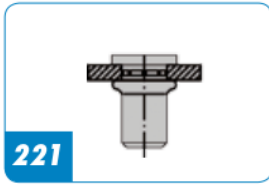

PolyGrip® aluminium



PolyGrip® steel

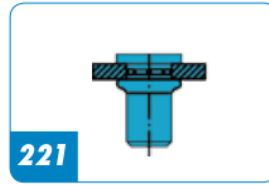

PolyGrip® stainless steel A2

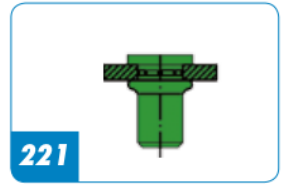

PolyGrip® stainless steel A4

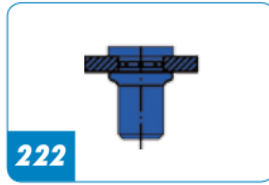

PolyGrip® splined steel



SoftGrip® steel and stainless steel A2

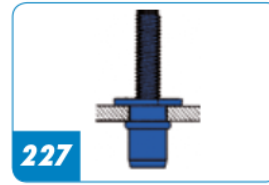

Blind rivet nut stud steel



Blind rivet nut stud steel half hexagonal

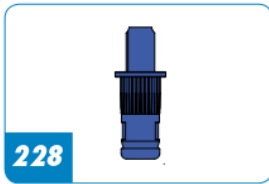

PolyGrip® blind rivet nut stud steel splined

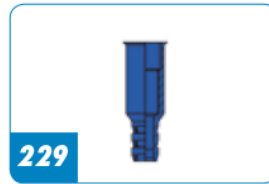

Blind rivet nuts with hose connection

Note: All steel blind rivet nuts are splined

Blind rivet nuts alu

Material: AlMg 3

Standard Dome head

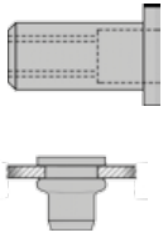

	Rivet body D, x L mm	Grip range mm	Part no.	Quantity per box
M 4 Hole-Ø: 6.1 mm	6 x 11.0	0.25 - 3.0	143 3676	A 500
	6 x 13.0	2.5 - 4.5	143 3677	"
M 5 Hole-Ø: 7.1 mm	7 x 11.5	0.25 - 3.0	143 3678	A 500
	7 x 13.5	2.5 - 5.0	143 3679	"
M 6 Hole-Ø: 9.1 mm	9 x 15.5	0.25 - 3.5	143 3680	A 250
	9 x 18.0	3.0 - 5.5	143 3681	"
M 8 Hole-Ø: 11.1 mm	11 x 17.0	0.25 - 3.5	143 3682	A 100
	11 x 20.0	3.0 - 6.0	143 3683	"
M 10 Hole-Ø: 12.1 mm	12 x 17.5	0.25 - 3.5	143 3684	A 100
	12 x 20.5	3.0 - 6.0	145 5345	"

Small head

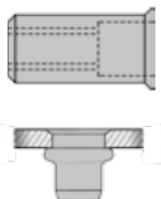

	Rivet body D, x L mm	Grip range mm	Part no.	Quantity per box
M 4 Hole-Ø: 6.1 mm	6 x 12.0	0.5 - 3.0	143 3685	A 500
M 5 Hole-Ø: 7.1 mm	7 x 12.5	0.5 - 3.0	143 3686	A 500
M 6 Hole-Ø: 9.1 mm	9 x 15.5	0.5 - 3.5	143 3687	A 250
M 8 Hole-Ø: 11.1 mm	11 x 17.0	0.5 - 3.5	143 3688	A 100

Countersunk (90°)

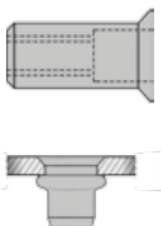

	Rivet body D, x L mm	Grip range mm	Part no.	Quantity per box
M 4 Hole-Ø: 6.1 mm	6 x 12.0	1.5 - 3.5	145 5346	A 500
	6 x 13.5	3.0 - 5.0	145 5347	"
M 5 Hole-Ø: 7.1 mm	7 x 13.5	1.5 - 4.0	145 5348	A 500
	7 x 15.5	3.5 - 6.0	145 5349	"
M 6 Hole-Ø: 9.1 mm	9 x 17.0	1.5 - 4.5	145 5350	A 250
	9 x 19.0	4.0 - 6.5	145 5351	"
M 8 Hole-Ø: 11.1 mm	11 x 18.5	1.5 - 4.5	145 5352	A 100
	11 x 20.5	4.0 - 6.5	145 5353	"
M 10 Hole-Ø: 12.1 mm	12 x 19.0	1.5 - 4.5	145 5354	A 100
	12 x 21.0	4.0 - 6.5	145 5355	"

The maximum tightening torque and the threaded breaking force and shear strengths for all blind rivet nuts can be found on pages 204 and 205.

For head diameters, please report to page 217.

Blind rivet nuts steel splined

Material: Steel, zinc-plated

Standard Dome head

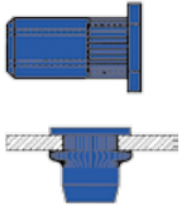

	Rivet body D _i x L mm	Grip range mm	Part no.	Quantity per box
M 4 Hole-Ø: 6.1 mm	6 x 11.0	0.25 - 3.0	143 3703	A 500
	6 x 13.0	2.5 - 4.5	145 5362	"
M 5 Hole-Ø: 7.1 mm	7 x 11.5	0.25 - 3.0	143 3704	A 500
	7 x 13.5	2.5 - 5.0	143 3705	"
M 6 Hole-Ø: 9.1 mm	9 x 15.5	0.25 - 3.5	143 3706	A 250
	9 x 18.0	3.0 - 5.5	145 5363	"
	9 x 21.0	5.5 - 8.0	145 0364	A 200
	9 x 24.5	8.0 - 11.0	145 0365	"
M 8 Hole-Ø: 11.1 mm	11 x 17.0	0.25 - 3.5	143 3707	A 100
	11 x 20.0	3.0 - 6.0	143 3708	"
	11 x 21.5	6.0 - 9.0	145 0366	"
	11 x 25.5	9.0 - 12.0	145 0367	"
M 10 Hole-Ø: 12.1 mm	12 x 17.5	0.25 - 3.5	143 3709	A 100
	12 x 20.5	3.0 - 6.0	143 3710	"

Small head

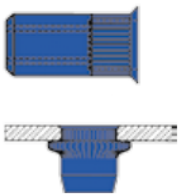

	Rivet body D _i x L mm	Grip range mm	Part no.	Quantity per box
M 4 Hole-Ø: 6.1 mm	6 x 12.0	0.25 - 3.0	143 3711	A 500
M 5 Hole-Ø: 7.1 mm	7 x 12.5	0.25 - 3.0	143 3712	A 500
M 6 Hole-Ø: 9.1 mm	9 x 15.5	0.25 - 3.5	143 3713	A 250
	9 x 19.0	3.5 - 5.5	145 0368	"
	9 x 22.0	5.5 - 8.0	145 0369	"
M 8 Hole-Ø: 11.1 mm	11 x 17.0	0.25 - 3.5	143 3714	A 100
	11 x 21.0	3.5 - 5.5	145 0370	"
	11 x 23.0	5.5 - 9.0	145 0371	"
M 10 Hole-Ø: 12.1 mm	12 x 18.0	1,5 - 4,5	146 4890	"
	12 x 20,0	4,0 - 6,5	146 4889	"

Blind rivet nuts steel splined

Material: Steel, zinc-plated

Countersunk (90°)

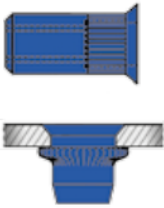

	Rivet body D ₁ x L mm	Grip range mm	Part no.	Quantity per box
M 4 Hole∅: 6.1 mm	6 x 12.0	1.5 - 3.5	145 5365	A 500
	6 x 13.5	3.0 - 5.0	145 5366	"
M 5 Hole∅: 7.1 mm	7 x 13.5	1.5 - 4.0	145 5367	A 500
	7 x 15.5	3.5 - 6.0	145 5368	"
M 6 Hole∅: 9.1 mm	9 x 17.0	1.5 - 4.5	145 5369	A 250
	9 x 19.0	4.0 - 6.5	145 5370	"
	9 x 23.0	6.5 - 9.0	145 0372	A 200
M 8 Hole∅: 11.1 mm	11 x 18.5	1.5 - 4.5	143 3715	A 100
	11 x 20.5	4.0 - 6.5	145 5371	"
	11 x 23.0	6.5 - 9.0	145 0373	"
M 10 Hole∅: 12.1 mm	12 x 19.0	1.5 - 4.5	145 5372	A 100
	12 x 21.0	4.0 - 6.5	145 5373	"

The maximum tightening torque and the threaded breaking force and shear strengths for all blind rivet nuts can be found on pages 204 and 205.

For head diameters, please report to page 217.

Blind rivet nuts steel

Material: Steel, zinc-plated

Square bodied Standard Dome head

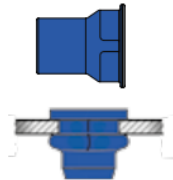

	Rivet body D, x L mm	Grip range mm	Part no.	Quantity per box
M 5 SW7.1 +0.1	7 x 12	0,5 - 3,0	146 4921	A 500
M 6 SW9.1 +0.1	9 x 15.5	0,5 - 3,0	146 4922	A 250
M 8 SW11.1 +0.1	11 x 17	0,5 - 3,0	146 4923	A 100

Half hexagonal Standard Dome head

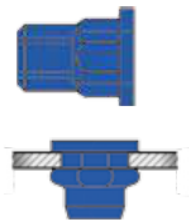

	Rivet body D, x L mm	Grip range mm	Part no.	Quantity per box
M 4 SW6 +0.1	6 x 11.0	0.5 - 2.0	145 5377	A 500
M 5 SW7 +0.1	7 x 12.0	0.5 - 3.0	145 5378	A 500
M 6 SW9 +0.1	9 x 15.5	0.5 - 3.0	145 5379	A 250
M 8 SW11 +0.1	11 x 17.0	0.5 - 3.0	143 3716	A 100

Half hexagonal Small head

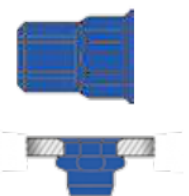

	Rivet body D, x L mm	Grip range mm	Part no.	Quantity per box
M 4 SW6 +0.1	6 x 11.0	0.5 - 2.0	145 5380	A 500
M 5 SW7 +0.1	7 x 12.5	0.5 - 3.0	145 5381	A 500
M 6 SW9 +0.1	9 x 15.5	0.5 - 3.0	145 5382	A 250
M 8 SW11 +0.1	11 x 17.0	0.5 - 3.0	145 5383	A 100

The maximum tightening torque and the threaded breaking force and shear strengths for all blind rivet nuts can be found on pages 204 and 205.

For head diameters, please report to page 217.

Blind rivet nuts stainless steel A2

Material: Stainless steel A2 1.4567



Standard Dome head

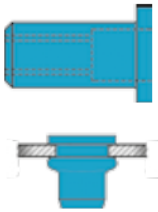

	Rivet body D ₁ x L mm	Grip range mm	Part no.	Quantity per box
M 4 Hole∅: 6.1 mm	6 x 11.0	0.25 - 3.0	145 5444	A 500
	6 x 13.0	2.5 - 4.0	145 5445	"
M 5 Hole∅: 7.1 mm	7 x 11.5	0.25 - 3.0	143 3725	A 500
	7 x 13.5	2.5 - 4.5	143 3726	"
M 6 Hole∅: 9.1 mm	9 x 15.5	0.25 - 3.5	145 5446	A 250
	9 x 18.0	3.0 - 5.5	145 5447	"
M 8 Hole∅: 11.1 mm	11 x 17.0	0.25 - 3.5	145 5448	A 100
	11 x 20.0	3.0 - 6.0	145 5449	"

Material surcharge will be added at a daily rate

Small head

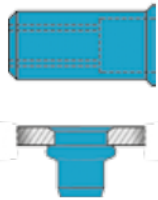

	Rivet body D ₁ x L mm	Grip range mm	Part no.	Quantity per box
M 4 Hole∅: 6.1 mm	6 x 12.0	0.25 - 3.0	143 3727	A 500
M 5 Hole∅: 7.1 mm	7 x 12.5	0.25 - 3.0	143 3728	A 500
M 6 Hole∅: 9.1 mm	9 x 15.5	0.25 - 3.5	143 3729	A 250
M 8 Hole∅: 11.1 mm	11 x 17.0	0.25 - 3.5	143 3730	A 100

Material surcharge will be added at a daily rate

Countersunk

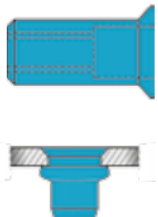

	Rivet body D ₁ x L mm	Grip range mm	Part no.	Quantity per box
M 4 Hole∅: 6.1 mm	6 x 12.0	1.5 - 3.0	143 3731	A 500
	6 x 13.0	2.5 - 4.0	145 5450	"
M 5 Hole∅: 7.1 mm	7 x 13.5	1.5 - 4.0	143 3732	A 500
	7 x 15.5	3.5 - 6.0	145 5451	"
M 6 Hole∅: 9.1 mm	9 x 17.0	1.5 - 4.5	143 3733	A 250
	9 x 18.5	4.0 - 6.0	145 5452	"
M 8 Hole∅: 11.1 mm	11 x 18.5	1.5 - 4.5	143 3734	A 100
	11 x 20.0	4.0 - 6.0	145 5453	"

Material surcharge will be added at a daily rate

Blind rivet nuts stainless steel A2 half hexagonal



Material: Stainless steel A2 1.4567

Standard Dome head

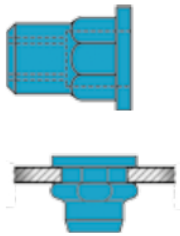

	Rivet body D, x L mm	Grip range mm	Part no.	Quantity per box
M 4 SW6 + 0.1	6 x 11.0	0.5 - 2.0	145 5454	A 500
M 5 SW7 + 0.1	7 x 12.0	0.5 - 3.0	145 5455	"
M 6 SW9 + 0.1	9 x 15.5	0.5 - 3.0	145 5456	A 250
M 8 SW11 + 0.1	11 x 17.0	0.5 - 3.0	145 5457	A 100

Material surcharge will be added at a daily rate

Small head

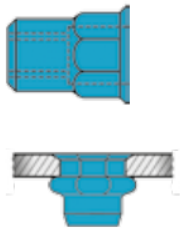

	Rivet body D, x L mm	Grip range mm	Part no.	Quantity per box
M 4 SW6 + 0.1	6 x 11.0	0.5 - 2.0	145 5458	A 500
M 5 SW7 + 0.1	7 x 12.0	0.5 - 3.0	145 5459	"
M 6 SW9 + 0.1	9 x 15.5	0.5 - 3.0	145 5460	A 250
M 8 SW11 + 0.1	11 x 17.0	0.5 - 3.0	145 5461	A 100

Material surcharge will be added at a daily rate

The maximum tightening torque and the threaded breaking force and shear strengths for all blind rivet nuts can be found on pages 204 and 205.

For head diameters, please report to page 217.

Blind rivet nuts stainless steel A4



Material: Stainless steel A4 1.4578

Standard Dome head

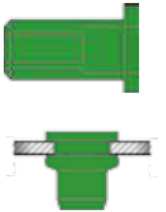

	Rivet body D, x L mm	Grip range mm	Part no.	Quantity per box
M 4 Hole-Ø: 6.1 mm	6 x 11.0	0.25 - 3.0	145 5468	A 500
	6 x 13.0	2.5 - 4.0	145 5473	"
M 5 Hole-Ø: 7.1 mm	7 x 11.5	0.25 - 3.0	145 5475	"
	7 x 13.5	2.5 - 4.5	145 5478	"
M 6 Hole-Ø: 9.1 mm	9 x 15.5	0.25 - 3.5	145 5462	A 250
	9 x 18.0	3.0 - 5.5	145 0381	"
M 8 Hole-Ø: 11.1 mm	11 x 17.0	0.25 - 3.5	145 5480	A 100
	11 x 20.0	3.0 - 6.0	145 5485	"

Material surcharge will be added at a daily rate

Small head

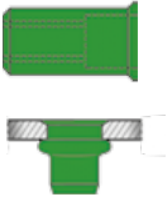

	Rivet body D, x L mm	Grip range mm	Part no.	Quantity per box
M 4 Hole-Ø: 6.1 mm	6 x 12.0	0.25 - 3.0	145 5472	A 500
M 5 Hole-Ø: 7.1 mm	7 x 12.5	0.25 - 3.0	145 5476	"
M 6 Hole-Ø: 9.1 mm	9 x 15.5	0.25 - 3.5	145 5465	A 250
M 8 Hole-Ø: 11.1 mm	11 x 17.0	0.25 - 3.5	145 5481	A 100

Material surcharge will be added at a daily rate

Countersunk

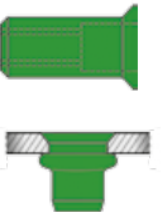

	Rivet body D, x L mm	Grip range mm	Part no.	Quantity per box
M 4 Hole-Ø: 6.1 mm	6 x 12.0	1.5 - 3.0	145 5471	A 500
	6 x 13.0	2.5 - 4.0	145 5474	"
M 5 Hole-Ø: 7.1 mm	7 x 13.5	1.5 - 4.0	145 5479	"
	7 x 15.5	3.5 - 6.0	145 0382	"
M 6 Hole-Ø: 9.1 mm	9 x 17.0	1.5 - 4.5	145 5464	A 250
	9 x 18.5	4.0 - 6.0	145 5463	"
M 8 Hole-Ø: 11.1 mm	11 x 18.5	1.5 - 4.5	145 5484	A 100
	11 x 20.0	4.0 - 6.0	145 5486	"

Material surcharge will be added at a daily rate



Blind rivet nuts stainless steel A4 half hexagonal



Material: Stainless steel A4 1.4578

Standard Dome head

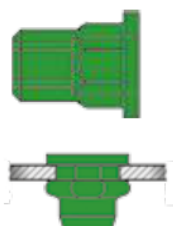

	Rivet body D, x L mm	Grip range mm	Part no.	Quantity per box
M 4 SW6 + 0.1	6 x 11.0	0.5 - 2.0	145 5469	A 500
M 5 SW7 + 0.1	7 x 12.0	0.5 - 3.0	144 6456	"
M 6 SW9 + 0.1	9 x 15.5	0.5 - 3.0	145 5466	A 250
M 8 SW11 + 0.1	11 x 17.0	0.5 - 3.0	145 5482	A 100

Small head

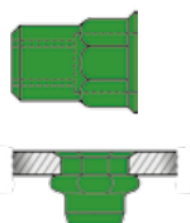

	Rivet body D, x L mm	Grip range mm	Part no.	Quantity per box
M 4 SW6 + 0.1	6 x 11.0	0.5 - 2.0	145 5470	A 500
M 5 SW7 + 0.1	7 x 12.0	0.5 - 3.0	145 5477	"
M 6 SW9 + 0.1	9 x 15.5	0.5 - 3.0	145 5467	A 250
M 8 SW11 + 0.1	11 x 17.0	0.5 - 3.0	145 5483	A 100

Material surcharge will be added at a daily rate

The maximum tightening torque and the threaded breaking force and shear strengths for all blind rivet nuts can be found on pages 204 and 205.

For head diameters, please report to page 217.

Blind rivet nuts Monel®

Material: Monel 400 NiCu30Fe 2.4360



Standard Dome head

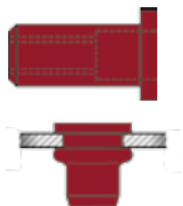

	Rivet body D, x L mm	Grip range mm	Part no.	Quantity per box
M 5 Hole-Ø: 7.1 mm	7 x 11.5	0.25 - 3.0	146 4292	A 500
M 6 Hole-Ø: 9.1 mm	9 x 15.5	0.25 - 3.5	145 5489	A 250
M 8 Hole-Ø: 11.1 mm	11 x 17.0	0.25 - 3.5	146 4291	A 100

Material surcharge will be added at a daily rate

Shaft geometry round and splined; all materials						
Dome head			Countersunk		Small head	
Size mm	Head diameter mm	Height of head mm	Head diameter mm	Height of head mm	Head diameter mm	Height of head mm
M 4	9	0.80	9	1.5 - 1.6	7.1	0.70
M 5	10	1.00	10	1.5 - 1.6	8.1	0.70
M 6	12	1.50	12	1.5 - 1.6	10.1	0.70
M 8	14	1.50	14	1.5 - 1.6	12.1	0.70
M 10	15	1.50	15	1.5 - 1.6	13.1	0.70

Shaft geometry half hexagonal; all materials				
Dome head			Small head	
Size mm	Head diameter mm	Height of head mm	Head diameter mm	Height of head mm
M 4	9	0.80	7.4	0.60
M 5	10	1.00	8.4	0.70
M 6	13	1.50	10.4	0.70
M 8	16	1.50	12.4	0.70

Blind rivet nuts alu closed end (CAP®)

Material: AlMg 3

Standard Dome head

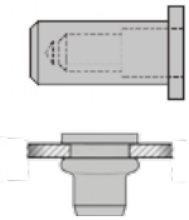

	Rivet body D _i x L mm	Grip range mm	Part no.	Quantity per box
M 4 Hole-Ø: 6.1 mm	6 x 15.0	0.25 - 3.0	146 4107	A 500
	6 x 17.0	2.5 - 4.5	146 4108	"
M 5 Hole-Ø: 7.1 mm	7 x 17.0	0.25 - 3.0	146 4109	A 500
	7 x 19.0	2.5 - 5.0	146 4110	A 250
M 6 Hole-Ø: 9.1 mm	9 x 21.5	0.25 - 3.5	146 4111	A 100
	9 x 24.5	3.0 - 5.5	146 4112	"
M 8 Hole-Ø: 11.1 mm	11 x 24.0	0.25 - 3.5	146 4113	A 100
	11 x 27.0	3.0 - 6.0	146 4114	"

Small head

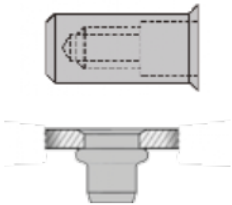

	Rivet body D _i x L mm	Grip range mm	Part no.	Quantity per box
M 4 Hole-Ø: 6.1 mm	6 x 16.0	0.25 - 3.0	146 4115	A 500
M 5 Hole-Ø: 7.1 mm	7 x 18.0	0.25 - 3.0	146 4116	A 500
M 6 Hole-Ø: 9.1 mm	9 x 21.5	0.25 - 3.5	146 4117	A 100

Countersunk (90°)

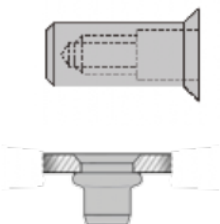

	Rivet body D _i x L mm	Grip range mm	Part no.	Quantity per box
M 4 Hole-Ø: 6.1 mm	6 x 16.0	1.5 - 3.0	146 4099	A 500
	6 x 17.5	3.0 - 5.0	146 4100	"
M 5 Hole-Ø: 7.1 mm	7 x 19.0	1.5 - 4.0	146 4101	A 250
	7 x 21.0	3.5 - 6.0	146 4102	"
M 6 Hole-Ø: 9.1 mm	9 x 23.0	1.5 - 4.5	146 4103	A 100
	9 x 25.0	4.0 - 6.5	146 4104	"
M 8 Hole-Ø: 11.1 mm	11 x 25.5	1.5 - 4.5	146 4105	A 100
	11 x 27.5	4.0 - 6.5	146 4106	"

The maximum tightening torque and the threaded breaking force and shear strengths for all blind rivet nuts can be found on pages 204 and 205.

For head diameters, please report to page 217.

Blind rivet nuts steel closed end (CAP®)

Material: Steel, zinc-plated

Standard Dome head

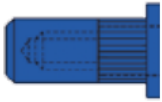

	Rivet body D _i x L mm	Grip range mm	Part no.	Quantity per box
M 4 Hole-Ø: 6.1 mm	6 x 15.0	0.25 - 3.0	143 2370	A 500
	6 x 17.0	2.5 - 4.5	143 2369	"
M 5 Hole-Ø: 7.1 mm	7 x 17.0	0.25 - 3.0	143 2373	A 500
	7 x 19.0	2.5 - 5.0	143 2374	"
M 6 Hole-Ø: 9.1 mm	9 x 21.5	0.25 - 3.5	143 2375	A 100
	9 x 24.5	3.0 - 5.5	143 2376	"
M 8 Hole-Ø: 11.1 mm	11 x 24.0	0.25 - 3.0	143 2377	A 100
	11 x 27.0	3.0 - 6.0	143 2378	"

Small head

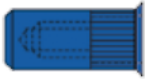

	Rivet body D _i x L mm	Grip range mm	Part no.	Quantity per box
M 4 Hole-Ø: 6.1 mm	6 x 16.0	0.25 - 3.0	146 4295	A 500
M 5 Hole-Ø: 7.1 mm	7 x 18.0	0.25 - 3.0	146 4294	A 500
M 6 Hole-Ø: 9.1 mm	9 x 21.5	0.25 - 3.5	146 4293	A 100

Countersunk (90°)

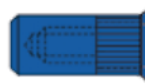

	Rivet body D _i x L mm	Grip range mm	Part no.	Quantity per box
M 4 Hole-Ø: 6.1 mm	6 x 16.0	1.5 - 3.0	143 2379	A 500
	6 x 17.5	3.0 - 5.0	143 2380	"
M 5 Hole-Ø: 7.1 mm	7 x 19.0	1.5 - 4.0	143 2381	A 250
	7 x 21.0	3.5 - 6.0	143 2382	"
M 6 Hole-Ø: 9.1 mm	9 x 23.0	1.5 - 4.5	143 2383	A 100
	9 x 25.0	4.0 - 6.5	143 2385	"
M 8 Hole-Ø: 11.1 mm	11 x 25.5	1.5 - 4.5	146 4297	A 100
	11 x 27.5	4.0 - 6.5	146 4296	"

The maximum tightening torque and the threaded breaking force and shear strengths for all blind rivet nuts can be found on pages 204 and 205.

For head diameters, please report to page 217.

PolyGrip® blind rivet nuts

**PolyGrip® blind rivet nuts –
The GESIPA® blind rivet nuts
with a large grip range**



The PolyGrip® blind rivet nuts

Die PolyGrip® blind rivet nuts are the logical further development of many years of experience with our PolyGrip® multi-range blind rivets. Thanks to the benefits of its large drilling hole tolerance and the option of covering various grip ranges with just one fastener, the PolyGrip® blind rivet nut has become a first-choice connector in many industrial applications and in trade.

Bringing together multiple dimensions saves handling and storage costs while also permanently reducing the risk of confusion in the workplace and the quality problems this can result in.

Large grip range: Ideally, the one PolyGrip® blind rivet nut can replace up to five different dimensions of DIN standard blind rivet nuts thanks to the large grip range.

Your benefits:

- Type simplification
- Limited type variety for reduced stocks
- Lower risk of confusion therefore fewer mistakes in production

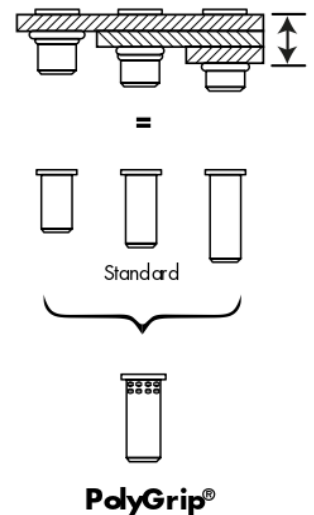

The best setting results can be achieved with GESIPA® FireBird® Pro!



PolyGrip® blind rivet nuts

Aluminium

Standard Dome head

Material: AlMg 2.5



	Rivet body D _i x L mm	Grip range mm	Part no.	Quantity per box
M 5 Hole-Ø: 7.1 mm	7 x 13.5	0.25 - 5.0	143 3791	A 500
M 6 Hole-Ø: 9.1 mm	9 x 18.0	0.25 - 6.0	143 3792	A 250
M 8 Hole-Ø: 11.1 mm	11 x 20.0	0.5 - 6.5	145 5561	A 100

Steel

Standard Dome head

Material: Steel
Surface: Zinc-plated



	Rivet body D _i x L mm	Grip range mm	Part no.	Quantity per box
M 5 Hole-Ø: 7.1 mm	7 x 13.5	0.5 - 5.0	143 3793	A 500
M 6 Hole-Ø: 9.1 mm	9 x 18.0	0.25 - 6.0	143 3794	A 250
M 8 Hole-Ø: 11.1 mm	11 x 20.0	0.5 - 6.5	143 3795	A 100

Stainless Steel

A2 Standard Dome head

Material:
Stainless Steel A2 1.4567, polished



	Rivet body D _i x L mm	Grip range mm	Part no.	Quantity per box
M 5 Hole-Ø: 7.1 mm	7 x 13.5	0.25 - 5.0	143 3796	A 500
M 6 Hole-Ø: 9.1 mm	9 x 18.0	0.5 - 6.0	143 3797	A 250
M 8 Hole-Ø: 11.1 mm	11 x 20.0	0.5 - 6.5	143 3798	A 100

Material surcharge will be added at a daily rate

Stainless Steel

A4 Standard Dome head

Material:
Stainless Steel A4 1.4578, polished



	Rivet body D _i x L mm	Grip range mm	Part no.	Quantity per box
M 5 Hole-Ø: 7.1 mm	7 x 13.5	0.25 - 5.0	145 0393	A 500
M 6 Hole-Ø: 9.1 mm	9 x 18.0	0.5 - 6.0	145 5567	A 250
M 8 Hole-Ø: 11.1 mm	11 x 20.0	0.5 - 6.5	145 5568	A 100

Material surcharge will be added at a daily rate

The maximum tightening torque and the threaded breaking force and shear strengths for all blind rivet nuts can be found on pages 204 and 205.

For head diameters, please report to page 217.

PolyGrip® Blind rivet nuts splined

Splined multi-range blind rivet nuts for improved anti-twist protection in soft materials



The new GESIPA® splined PolyGrip® blind rivet nuts made from M6 and M8 steel are a further development of the well-proven PolyGrip® multi-range blind rivet nuts. They combine the advantages of covering large grip ranges with the knurling for increased anti-twist protection.

The long longitudinal knurling ensures uniform setting characteristics over the entire grip range and a large closing head.

In the ideal case, the splined PolyGrip® blind rivet nut can replace up to 5 different standard DIN dimensions. This saves handling and storage costs while also reducing the risk of confusion in the workplace.

Steel Standard Dome head

Material: Steel
Surface: galvanised

	Rivet body D, x L mm	Grip range mm	Part no.	Quantity per box
M 6 Hole-Ø: 9.1 mm	9 x 18.0	0.5 - 6.5	145 5562	A 250
M 8 Hole-Ø: 11.1 mm	11 x 20.0	0.5 - 8.0	145 5563	A 100



The best setting results can be achieved with GESIPA® FireBird® Pro!



SoftGrip® Blind rivet nuts

NEW

SoftGrip® blind rivet nuts from GESIPA® make it easy to produce high-quality threads in sensitive lightweight applications



Carbon fibre-reinforced plastics (CFRP) offer indisputable and fascinating advantages when it comes to saving weight. They are, however, particularly demanding when selecting the partner material. Standard joining elements simply will not do for this high-grade material. GESIPA® has now developed a blind rivet nut for composite materials that meets the demanding requirements.

The SoftGrip® blind rivet nut from GESIPA® is a further development of the tried and tested PolyGrip® multi-range blind rivet nut. With the aid of a precisely controlled setting procedure, the component is barely subjected to bearing stress and contact pressure. The bulb that forms flat on the component with a large (larger than average) diameter ensures outstanding mechanical properties. Component damage such as crushing, cracking, delamination etc. are therefore effectively avoided.

Thanks to the controlled formation of the bulb and the thus reduced bearing stress, minimal edge spacing of the blind rivet nut can be realised in connection with large hole tolerances. The use of high-grade stainless steel A2 materials (A4 on request) additionally makes the load bearing thread highly resistant to corrosion.

Advantages

- Fast processes
- Tight fit with the components
- Process monitoring and process control are possible
- High strength
- Not dependent on surface properties
- No other materials required (adhesive)
- No ageing
- Accessible from one side
- No delamination of the CFRP
- Smaller edge spacing of the holes
- Large grip range
- Stainless steel for high corrosion resistance
- Higher hole drilling tolerances

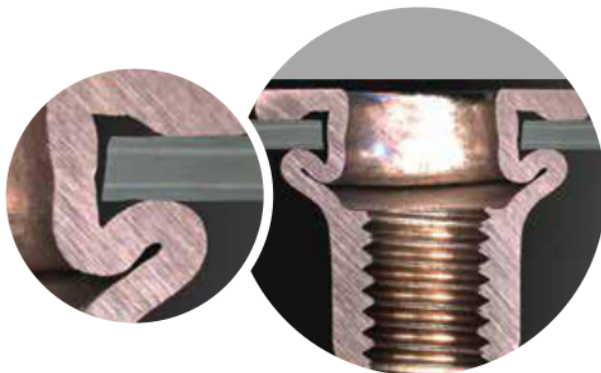

SoftGrip® Blind rivet nuts steel

NEW

Perfect for plastics and soft materials

As a cost-effective alternative to the stainless steel SoftGrip®, the SoftGrip® steel blind rivet nut is the ideal functional component for plastics and soft materials where there is no need to prevent contact corrosion.



Steel Standard Dome head

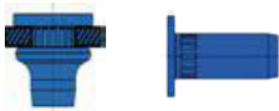

	Rivet body D _i x L mm	Grip range mm	Part no.	Quantity per box
M 6 - K 13 Hole-Ø: 9.1 mm	9 x 20.0	0.5 - 4.5	156 8810	A 100
	9 x 20.0	4.5 - 6.5	156 8811	A 100
M 6 - K 16 Hole-Ø: 9.1 mm	9 x 20.0	0.5 - 4.5	156 8874	A 100
	9 x 20.0	4.5 - 6.5	156 8875	A 100
M 6 - K 18 Hole-Ø: 9.1 mm	9 x 20.0	0.5 - 4.5	156 8878	A 100
	9 x 20.0	4.5 - 6.5	156 8879	A 100

The standard SoftGrip® can be adapted in accordance with special requirements and specific customer requests in many areas. Other dimensions available on request.

SoftGrip® Blind rivet nuts stainless steel

NEW

Ideal for CFRP applications

The high-quality materials stainless A2 and A4 also ensure that the load-bearing thread is highly resistant to corrosion, making the GESIPA® SoftGrip® stainless steel blind rivet nut ideal for use with CFRP materials.



Stainless Steel A2

Standard Dome head

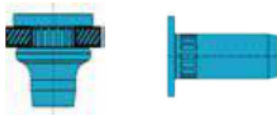

	Rivet body D ₁ x L mm	Grip range mm	Part no.	Quantity per box
M 6 - K 16 Hole-Ø: 9.1 mm	9 x 20.0	0.5 - 4.5	152 3786	A 100
	9 x 20.0	4.5 - 6.5	152 3787	A 100
M 6 - K 18 Hole-Ø: 9.1 mm	9 x 20.0	0.5 - 4.5	156 7589	A 100
	9 x 20.0	4.5 - 6.5	156 8804	A 100

Stainless Steel A4

Standard Dome head

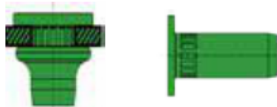

	Rivet body D ₁ x L mm	Grip range mm	Part no.	Quantity per box
M 6 - K 16 Hole-Ø: 9.1 mm	9 x 20.0	0.5 - 4.5	156 8805	A 100
	9 x 20.0	4.5 - 6.5	156 8806	A 100
M 6 - K 18 Hole-Ø: 9.1 mm	9 x 20.0	0.5 - 4.5	156 8807	A 100
	9 x 20.0	4.5 - 6.5	156 8808	A 100

Blind rivet nut studs steel

Combination of blind rivet nut and stud as an alternative or replacement for welding studs and press-in studs



As a combination of blind rivet nut and screw, blind rivet nut studs offer a technical as well as cost-effective alternative to welding studs or other multi-piece T-slot systems. The blind rivet nut stud has two functions. On the one hand, it joins thin materials even if they are different. On the other hand, with the reliably and permanently fixed screw it provides an additional fastening point or a positioning aid. Different dimensions, materials and head shapes cover a wide range of applications. In addition to the standard range, application-specific applications are possible.

Advantages

- Dual function: Joining materials and providing additional fastening point (threaded stud)
- Access only required from one side
- High load bearing capacity of thread
- Simple, neat and fast processing
- Space-saving
- No damage to painted surfaces
- No heat transfer, i.e. no change in material structure
- Suitable for repairing welding studs

Applications

The following applications are particularly suitable for the use of GESIPA® blind rivet nut studs:

- Accessible from one side
- Thin carrier materials such as sheet metal, plastics, etc.
- Pre-centring required
- Heat transfer, e.g. welding joined materials not possible or permitted
- Surface coatings must not be damaged
- Making electrically conductive joints
- Fast repairs of welding studs

GESIPA® blind rivet nut studs can be set without any problems with the GESIPA® blind rivet nut setting tools FireBird®, GBM 95 and FireFox® using corresponding adapters for blind rivet nut studs (see tool description).

Blind rivet nut studs steel

Steel Standard Dome head

Material:
Steel, zinc-plated

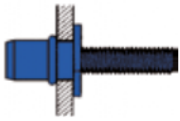

	Rivet body D ₁ x L mm	Grip range mm	Thread protrusion min. mm	Part no.	Quantity per box
M 4 Hole-Ø: 6.1 mm	6 x 11.0	0.25 - 3.0	10.0	143 3665	A 200
M 5 Hole-Ø: 7.1 mm	7 x 11.5	0.25 - 3.0	11.5	145 5330	A 150
M 6 Hole-Ø: 9.1 mm	9 x 15.5	0.25 - 3.0	13	145 5331	A 150
M 8 Hole-Ø: 11.1 mm	11 x 17.0	0.25 - 3.0	15.5	145 5332	A 100

Steel half hexagonal Standard

Material:
Steel, zinc-plated

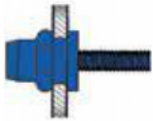

	Rivet body D ₁ x L mm	Grip range mm	Thread protrusion min. mm	Part no.	Quantity per box
M 4 Hole-Ø: SW6 + 0.1 mm	6 x 11.0	0.5 - 2.0	10.0	145 0359	A 200
M 5 Hole-Ø: SW7 + 0.1 mm	7 x 12	0.5 - 3.0	11.5	145 0360	A 150
M 6 Hole-Ø: SW9 + 0.1 mm	9 x 15.5	0.5 - 3.0	13	145 0361	A 100
M 8 Hole-Ø: SW11 + 0.1 mm	11 x 17.0	0.5 - 3.0	15.5	145 0362	A 100

Size mm	Shear strength N (kp)	Tensile strength N (kp)	Max. torque Nm
M 4	5,160 (525)	6,030 (614)	3.0
M 5	7,200 (733)	10,800 (1,100)	6.0
M 6	10,800 (1,100)	17,800 (1,812)	13.0
M 8	18,400 (1,873)	27,800 (2,830)	26.0

The values were determined using a screw of the strength class 8.8.

Further dimensions, special surface treatments or materials are available on request.

Shaft geometry round and splined; all materials		
Dome head		
Size mm	Head diameter mm	Height of head mm
M 4	9	0.80
M 5	10	1.00
M 6	12	1.50
M 8	14	1.50

Shaft geometry half hexagonal; all materials		
Dome head		
Size mm	Head diameter mm	Height of head mm
M 4	9	0.80
M 5	10	1.00
M 6	13	1.50
M 8	16	1.50

PolyGrip® Blind rivet nut studs splined



The new GESIPA® splined PolyGrip® blind rivet nut studs made from M6 and M8 steel are a further development of the well-proven PolyGrip® multi-range blind rivet nuts. They combine the advantages of covering large grip ranges with the knurling for increased anti-twist protection.

The long longitudinal knurling ensures uniform setting characteristics over the entire grip range and a large closing head.

In the ideal case, the splined PolyGrip® blind rivet nut studs can replace up to 5 different standard DIN dimensions. This saves handling and storage costs while also reducing the risk of confusion in the workplace.

Steel

Standard Dome head

Material: Steel
Surface: galvanised



	Rivet body D, x L mm	Grip range mm	Thread protrusion min. mm	Part no.	Quantity per box
M 6 Hole-Ø: SW9 + 0.1 mm	9 x 18.0	0.5 - 6.0	13	146 4481	A 100
M 8 Hole-Ø: SW11 + 0.1 mm	11 x 20.0	0.5 - 8.0	15.5	146 4480	A 50



The best setting results can be achieved with GESIPA® FireBird® Pro!



Blind rivet nuts with hose connection



Part no. 145 5364

Specification:

BRN M5x7x26 KK steel, hose connection, galvanized

Grip range: 0.50 - 2.50 mm

Predrilled hole \varnothing : 7.1 + 0.1 mm

Use: Connection of a pneumatic hose (\varnothing 4 mm) for use with liquids and gases

Customer advantages:

- Reduction in variety of parts
- Better look (single colour)
- Reduced assembly effort
- Simplified assembly process
- Access to component from one side
- Saving on material and assembly costs

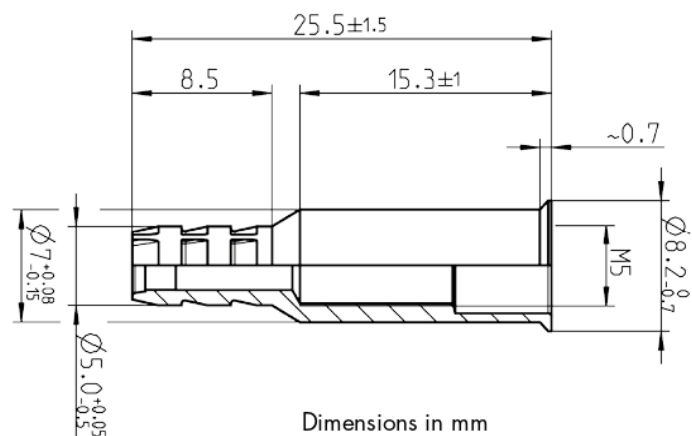

Sectors:

- Ventilation and air conditioning technology
- Pneumatics accessories
- Housing and container manufacturing



Example: Blind rivet nut with plastic hose

Cordless blind rivet nut setting tools

Blind rivet nut hand tools

232



GBM 10



GBM 30



FireFly



Flipper® Plus

Battery-powered blind rivet nut setting tools

242



FireBird® Pro



FireBird® Pro Gold Edition



FireBird®



FireBird® with conversion kit for blind rivet nut studs

What rivets what?

		Energy						
		M3	M4	M5	M6	M8	M10	M12
GBM 10	H	●	●	●	A			
GBM 30	H	●	●	●	●	●	AS	
FireFly	H	●	●	AS	A			
FireBird®, FireBird® Pro	B	●	●	●	●	AS	A	
FireBird® Pro Gold Edition	B	●	●	●	●	●	●	AS

H: Hand tool
B: Battery-powered tool
A: Alu/Copper
S: Steel
E: Stainless Steel

Blue box: All materials (ASE) can be riveted. Where there are exceptions, the letters of the rivetable materials are provided directly in the box.

Cordless blind rivet nut setting tool from GESIPA®
- Easy to operate, tried and tested, and simply good!



GBM 10

GESIPA® manual blind rivet nut setting tools - Easy to operate, tried and tested, always good but now even better!

GESIPA® has not only redesigned the classic GBM 10 tools themselves but also optimised the surfaces and handles.

By utilising a soft rubber material, the new ergonomically designed handles make it easier to work while substantially relieving the strain on the hands.



Blind rivet nut hand tool

NEW

Tried and tested technology and quality in a new design

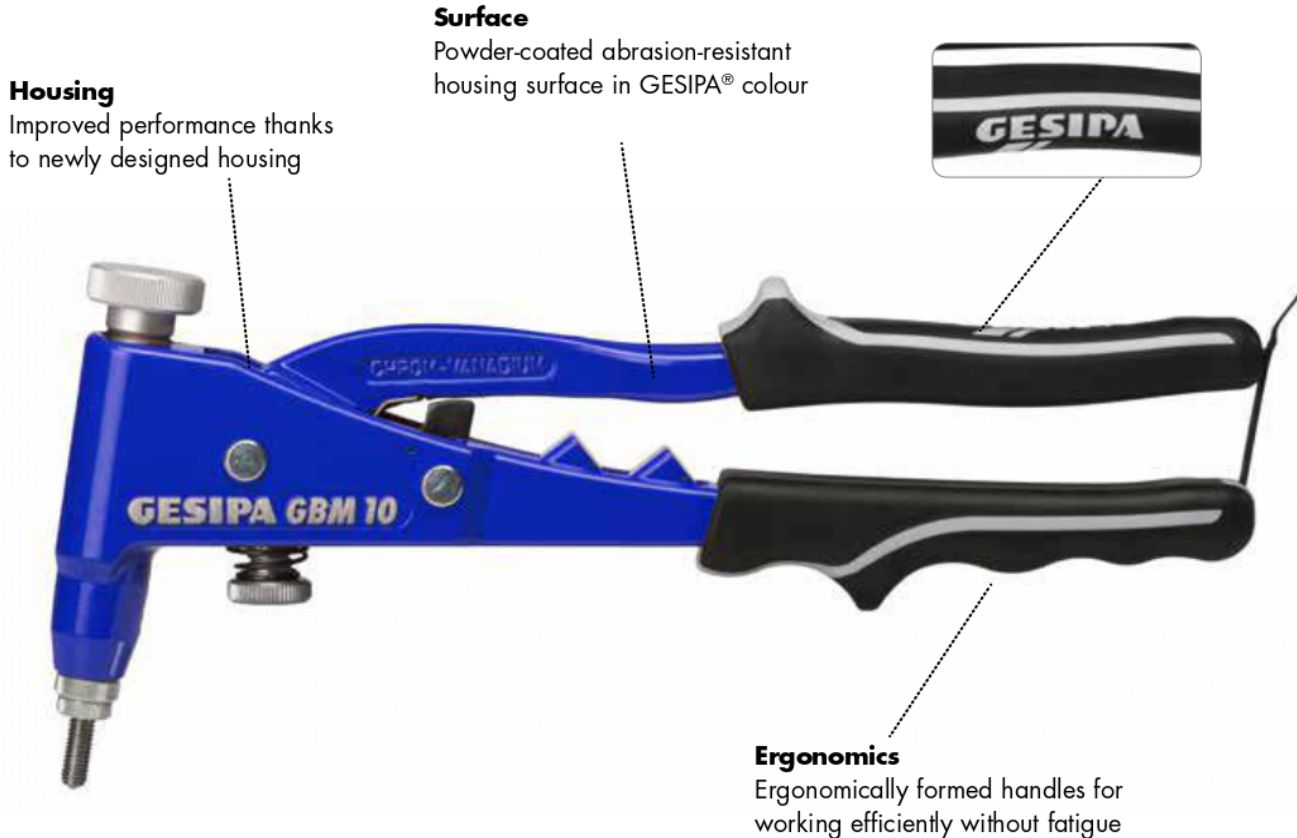

Handles

- Ergonomically formed handles for working efficiently without fatigue
- Improved haptics by use of softer material
- Non-slip even in oily environments
- Environmentally compatible thanks to PVC-free handles
- Visually upgraded by GESIPA® logo and contrast stripes
- Optimised locking clip

Housing

- Improved performance thanks to newly designed housing
- Powder-coated abrasion-resistant housing surface in GESIPA® colour
- GESIPA GBM 10 visually upgraded with Made in Germany lettering

Advantages

- Simple one-hand operation
- Effortless lever system
- Simple lift setting via a knurled nut for safe and complete setting of the blind rivet nuts
- Threaded mandrel protection via spring ring for fast tool-free replacement of the threaded mandrel
- Rugged design and durable
- Worldwide service and spare parts available for decades to come
- Made in Germany



GBM 10

Manual blind rivet nut setting tool with simple stroke setting



Working range

Blind rivet nuts from M3* up to M6 alu and up to M5 steel, brass and stainless steel

Technical data

Weight: 600 g
Total length: 260 mm
Stroke: 7 mm

Accessories

Standard: Threaded mandrel and nosepiece (optional M4 - M6)
Maintenance instructions with spare parts list
Stroke table

Features

- Simple lift setting via a knurled nut for safe and complete setting of the blind rivet nuts
- Threaded mandrel protection via spring ring for fast tool-free replacement of the threaded mandrel
- With opening spring for simple handling
- Body in high-quality die cast aluminium
- Body head made of forged chrome-vanadium steel
- Ergonomic handles

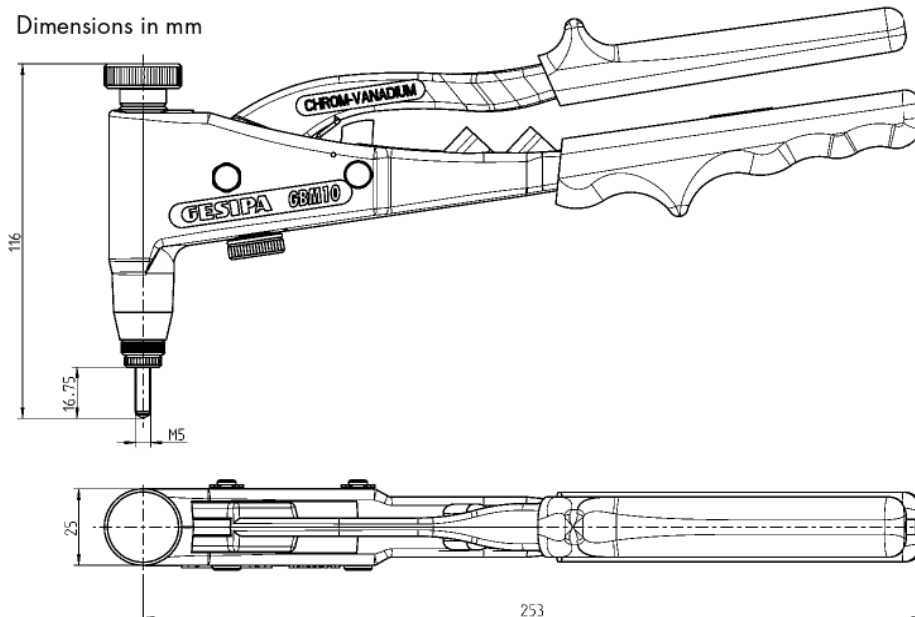

Blind rivet nut hand tool

NEW

Threaded mandrels and nosepieces

Article	Part no.
Threaded mandrel M3*	145 7096
Threaded mandrel M4	143 4776
Threaded mandrel M5	143 4779
Threaded mandrel M6	143 4781
Nosepiece M3*	145 7095
Nosepiece M4	143 4777
Nosepiece M5	143 4780
Nosepiece M6	143 4782

*Available as special accessoires

GBM 10 – M5
Part no. 143 4761

GBM 10 – M4
Part no. 145 7087

GBM 10 – M6
Part no. 145 7088

Blind rivet nut box

GBM 10 with threaded mandrel and nosepiece M5

including threaded mandrels and nosepieces M 4 and M 6, different blind rivet nut dimensions M 4 to M 6 made of alu for joint thicknesses of 0.25 to 3 mm.

Incl. 4 blind rivet nut sizes:

Alu M4 x 6 x 11.0 mm
Alu M5 x 7 x 11.5 mm
Alu M5 x 7 x 13.5 mm
Alu M6 x 9 x 15.5 mm



Part no. 143 5455

7

GESIPA®-Service*

GESIPA® – Comprehensive range of services from under one roof

01 Maintenance & Servicing Agreements

Regular servicing and maintenance are required to ensure processes and production runs smoothly. Servicing and maintenance are the foundation for guaranteeing high availability of your production facilities where downtimes are minimised, thus keeping costs down. These procedures also increase operational safety thereby protecting your personnel.

02 Technical Talks

Whether in our Demonstration Center, on your premises or at conferences: when it comes to selecting the venue and time we are really flexible. Talks aimed at specific target groups are of course no problem.

03 Training

We hold training courses for our customers' staff at our training centres or, if required, on site. The innovative training programme includes training courses on equipment, GAV systems as well as foundation and advanced courses.

04 Commissioning

Following the installation of a machine, comprehensive customer service is provided by our resourceful service team. The service team carries out both the commissioning as well as the maintenance of the machine.

05 Replacement Equipment Hire (GESIPA® special models)

To ensure your production process keeps running smoothly we stock a range of equipment for hire. You can make use of this equipment in maintenance and repair phases. Or when your own equipment pool is unable to deal with peaks in orders. We are here to help!

06 Factory Calibration

Process-monitored riveting tools are calibrated based on applicable test standards as part of the Gesipa calibration service. The calibration standard used is verified by routine test equipment monitoring. We can also carry out the calibration procedure directly on your premises.

07 Firmware Update

Firmware updates are available on request to keep your processing systems up-to-date, making sure they operate reliably safely and efficiently at all times.

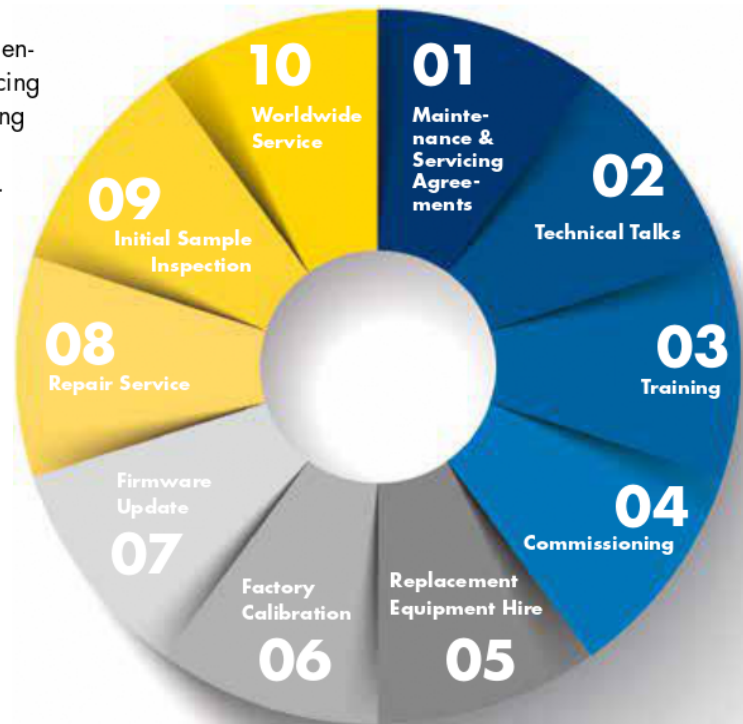

08 Repair Service

GESIPA® processing tools are manufactured to the highest quality standards. However, should repairs ever become necessary our technicians will provide fast and reliable assistance. The benefits of the GESIPA® repair service:

- Repair by qualified technical personnel
- Use of genuine spare parts
- Safety check after every repair
- Retain the warranty and tool availability

09 Initial Sample Inspection (PPAP, VDA 2)

Initial sample inspection verifies that, prior to the start of series production, the customer requirements agreed upon in the specification as well as other requirements (e.g. legislation, standards) in terms of the product and process are met. The same also applies to the annual re-qualification

10 Worldwide Service

Over 700 members of staff at six production sites worldwide – three of which in Germany – produce with commitment and passion high quality and innovative products. Sales abroad are handled by 12 subsidiaries and more than 40 international representatives.

*These services vary specific to country and are based on the service programmes available at the Walldorf/Germany site.

GBM 30

Manual blind rivet nut setting tool with quick drilling unit



Working range

Blind rivet nuts from M3* up to M10
alu and steel and up to M8 brass and stainless steel

Technical data

Weight: 1.8 kg
Total length: 470 mm
Stroke: 7 mm

Accessories

Standard: Threaded mandrel and nosepiece
(optional M5 - M10)
Maintenance instructions with spare parts list
Stroke table

Features

- Quick drill configuration for fast and simple drilling in and out of the threaded mandrel
- Favourable transmission ratio for low force application even when setting larger blind rivet nuts
- Simple lift setting via a lift scale for safe and complete setting of the blind rivet nuts
- Fast tool-free replacement of the threaded mandrel



GBM 30 – M6
Part no. 143 4790

GBM 30 – M5
Part no. 145 7132

GBM 30 – M8
Part no. 145 7133

GBM 30 – M10
Part no. 145 7134

Article	Part no.
Threaded mandrel M3*	143 4799
Threaded mandrel M4*	143 4801
Threaded mandrel M5	143 4791
Threaded mandrel M6	143 4793
Threaded mandrel M8	143 4795
Threaded mandrel M10	143 4797
Nosepiece M3*	143 4800
Nosepiece M4*	143 4802
Nosepiece M5	143 4792
Nosepiece M6	143 4794
Nosepiece M8	143 4796
Nosepiece M10	143 4798

*Available as special accessories

FireFly

Force and intelligence for setting blind rivet nuts

Smart handling

- The well-proven principle of operation of the GESIPA® hand riveting tool Flipper® spares up to 40% of the hand force for setting blind rivet nuts
- A special lever design as well as the ratchet mechanism provide a reduction of hand force
- Exchange of nosepiece and threaded mandrel
- The total stroke is 9 millimeter long for setting of new generation multigrip blind rivet nuts like new the GESIPA® PolyGrip® blind rivet nuts
- Tool-free setting of stroke and threaded mandrel lengths allows simple setting of blind rivets of different lengths

Working range

Blind rivet nuts from M3 up to M6 aluminium as well as from M3 up to M5 steel

Technical data

Total stroke:	9 mm
Single action stroke:	1.8 mm
Weight:	750 g



Dimensions in mm

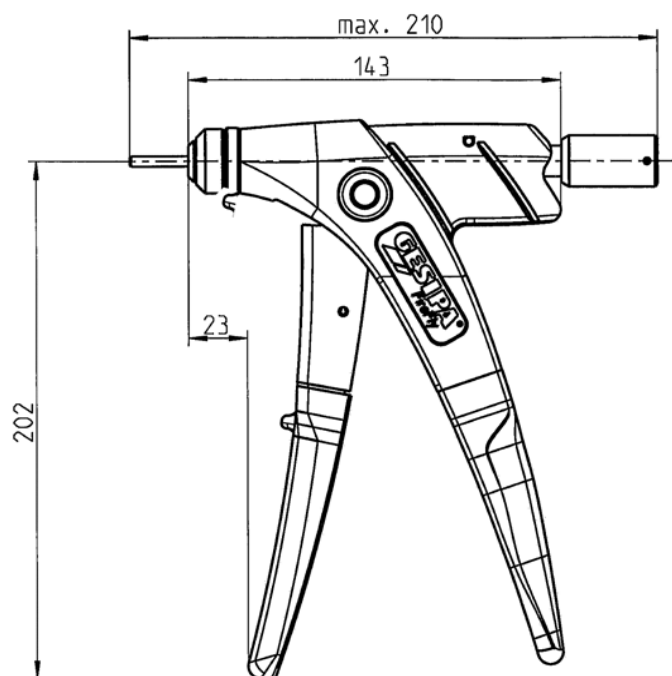
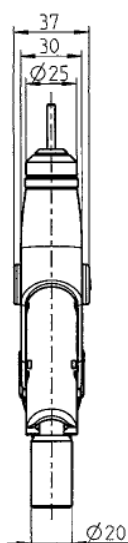

FireFly – Accessories

FireFly box

Equipped with M5 nosepiece and threaded mandrel in plastic carrying case, with 2 mini packs alu blind rivet nuts M4 and M5 as well as nosepiece and threaded mandrel M4, operating instructions and stroke adjustment list



Part no. 143 5453

Refill mini packs for blind rivet nuts

M4 x 6 x 13.0

Part no. 143 3700

M5 x 7 x 13.5

Part no. 143 3701

Retrofit set for blind rivet nut studs

	Part no.	BRN thread protrusion	
		min.	max.*
M4	143 4009	8	22
M5	143 4010	9	22
M6	143 4011	10	22

* A corresponding extended nosepiece must be used for thread protrusions > 22 mm.

Threaded mandrels and nosepieces

Article	Part no.
Threaded mandrels M3	143 4002
Threaded mandrels M4	143 4001
Threaded mandrels M5	143 4000
Threaded mandrels M6	143 4008
Nosepiece insert M3	143 3995
Nosepiece insert M4	143 3994
Nosepiece insert M5	143 3993
Nosepiece insert M6	143 3997

Article	Part no.
Threaded mandrels 6 - 32 UNC	143 4019
Threaded mandrels 8 - 32 UNC	143 4020
Threaded mandrels 10 - 24 UNC	143 4021
Threaded mandrels 10 - 32 UNF	143 4022
Threaded mandrels 1/4" - 20 UNC	143 4023
Nosepiece insert 6 - 32 UNC	143 4024
Nosepiece insert 8 - 32 UNC	143 4025
Nosepiece insert 10 - 24 UNC	143 4026
Nosepiece insert 1/4" - 20 UNC	143 4027

The nosepiece insert 10 - 24 UNC can be used for threaded mandrels 10 - 24 UNC and 10-32 UNF

FireFly in cardboard box



Equipped with a nosepiece and threaded mandrel, operating instructions and stroke table

Article	Part no.
FireFly M5 in card-board box	143 5454
FireFly M3 in card-board box	145 7653
FireFly M4 in card-board box	145 7654
FireFly M6 in card-board box	145 7655
FireFly 6 - 32 UNC in card-board box	145 7656
FireFly 8 - 32 in card-board box	145 7657
FireFly 10 - 24 UNC in card-board box	145 7658
FireFly 10 - 32 UNF in card-board box	145 7659
FireFly 1/4" - 20 UNC in card-board box	145 7660

Combi setting tool Flipper® Plus



Converted in under 1 minute in just a few simple steps

1. Removal

Remove the parts shown in the image



2. Installation

Install the threaded mandrel and nosepiece



3. Converted

Converted to a blind rivet nut setting tool



One setting tool – two functions

NEW

Virtually tool-free conversion from blind rivet to blind rivet nut setting tool

Working range blind rivets

Blind rivets up to 5 mm Ø aluminium and 4 mm Ø steel and stainless steel

Working range blind rivet nuts

Blind rivet nuts from M4 up to M6 aluminium as well as from M4 up to M5 steel

Technical data

Weight:	750 g
Total length:	217 mm
Total stroke:	16.2 mm
Single action stroke:	1.8 mm

Accessories

Nosepieces: 12/20, 12/24, 12/29, 12/M4, 12/M5 and 12/M6
Threaded mandrel conversion kit: M4, M5 and M6
1 maintenance wrench, 1 Allen key
1 jaw insertion aid
Operating instructions with spare parts list

Shared advantages

- New ratchet function
- The force increases when the handle is closed. This finding is put to good use in a special lever arrangement for setting blind rivets and blind rivet nuts: ergonomic design
- The required manual force is reduced by around 40 percent if actuated several times.
- Actuation lever with an opening spring for easy single-handed operation

Advantages when setting blind rivets

- Jaw mechanism with spring reset for safe and automatic mandrel ejection
- Rivet mandrel collection container can be clipped to the body casing and is easy to empty
- Larger device lift: a benefit when handling extra long blind rivets

Advantages when setting blind rivet nuts

- The total stroke is 16.2 millimeter long for setting of new generation multigrip blind rivet nuts like the GESIPA® PolyGrip® blind rivet nuts
- Simplified setting procedure for blind rivet nuts



Art.-Nr. 157 1258

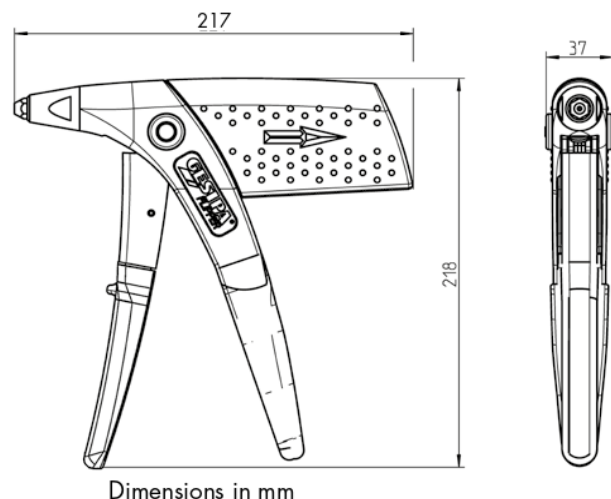

Dimensions in mm

7

The Bird Pro series



The Bird generation with brushless motor – Reliability for a high run and fast work sequence



The Bird Pro series

GESIPA®, which invented battery-powered blind riveting technology, has been producing the Bird series for over twenty years now. To this day, it sets the standard for the battery-powered blind riveting devices market. Not least due to changing customer requirements, the Bird family's modular system is updated on a regular basis. GESIPA® has therefore built a new platform that will supplement the current Bird series to meet the highest customer requirements. The new tools in this series are the **iBird® Pro, PowerBird® Pro Gold Edition, PowerBird® Pro, AccuBird® Pro, FireBird® Pro** and the **FireBird® Pro Gold Edition**.

Well-proven and ergonomically designed

The FireBird® Pro series features the same ergonomic design as the FireFox® series, already proven a thousand times over.

BLDC technology

A BLDC motor is a brushless DC motor that, instead of brushes that are susceptible to wear, uses electrical sensors to detect the rotor's position and commutate the stator coil via circuit breakers. A special software in the electronics controls the motor.

The advantages of a BLDC motor include high efficiency, long service life, particularly smooth running with a precision ball bearing and a reduction in electrical noise radiation.

Packaging

All tools in the Bird Pro Series come in a practical plastic case.

Battery-powered blind rivet setting tools with brushless motor

Li-ion batteries

The GESIPA® Bird Pro series is equipped as standard with a new rechargeable 2.1 Ah li-ion slide-on battery. These rechargeable li-ion batteries feature the new Deep Sleep function. To keep intrinsic consumption as low as possible, after a set idle time, the battery automatically assumes "Deep Sleep" mode. The battery can then be woken directly in the tool. There is no delay after being woken and the battery is immediately ready for use.



Charging technology

The GESIPA® li-ion chargers are available for 110 V and 240 V AC voltages. The charger comes with a Euro plug as standard. Other versions for China, UK and USA are available on request.

Characteristics

1. Autoreverse function

Immediately after mandrel break-off, this optional operating mode stops the pulling process and moves the jaw assembly back into the initial position. This saves time and energy while making sure the tool is immediately ready for use.

2. Lighting

The light-emitting diodes precisely aligned to the work piece are integrated into the adjusting ring. There are three possible switch positions:

Process-controlled: The diodes remain illuminated after the setting process, which allows a continuous workflow even in bad lighting conditions.

Torch function :

Steady glow of diode (max.10 minutes)

Lighting off: saves electricity.

3. Sliding battery

New sliding battery with exact optical and acoustic charging status display prevents unpleasant surprises. The deep sleep function and the electrical feedback of the braking energy extend the battery range – a battery charge lasts for up to 2,000 riveting operations. Additional catching grids prevent falling.

4. Charging unit

Charging unit with quick-charge function. The battery can be used again after only 45 minutes of charging, and is fully charged after just 90 minutes.



Advantages

- More powerful and longer-lasting BLDC motor for quick flow of work
- 25 mm stroke for long blind rivets
- Up to 20 kN setting force for particularly large blind rivets
- Variable lighting in the adjusting ring
- Increased stability due to larger, non-slip stand surface and lower centre of gravity
- Easy-to-grasp housing thanks to Softgrip
- New sliding battery
- Charging unit with quick-charge function

FireBird® Pro

Child's play! The new Fire-Bird® Pro with very easy adjustment by LED input field



Child's play!

- 1 Read off number
 - 2 Enter number
 - 3 Set blind rivet nut
- ➔ Done!

1

FireBird® Pro / FireBird® Pro Gold Edition
 Setzkraftvoreinstellung / Setting force pre-adjustment

	M3	M4	M5	M6	M8	M10	M12
Alu Alu	1	15	25	55	70	75	90
Stahl Steel	10	35	60	80	85	90	99
Edelstahl Stainless steel	15	55	65	85	95	99	-

Werte dienen nur als Einstellhilfe!
Data are just an adjustment aid!

GESIPA®

Setting force guide - Example: Steel M5



Advantages at a glance

Threaded mandrel

- Mandrel quick-change system
- Nosepiece and mandrel module taken from FireFox®

Technical facts

- Almost double the pulling displacement from 5.5 to 10 mm
- Double the previous setting speed
- Setting force increased to 20 KN by new BLDC motor (only FireBird® Pro Gold Edition)
- Fully automatic screw-off procedure after setting

LED input field

- Split LED input field
- Switches to energy-saving mode after 15 seconds
- Plastic cover to avoid damage and inadvertently changing the setting
- Presetting in steps of 10 and fine adjustment with 99 individual settings
- 10 freely selectable program memories

Trigger

- Automatic screw-on after pressing the switch

Threaded mandrel magazine

- Storage of mandrels in the practical, screw-on mandrel magazine
- Three mandrels and matching nosepieces included in scope of delivery



7

Rechargeable battery

- Li-ion slide-on 2.1 Ah battery pack (standard)
- When the battery is discharged, the tool switches off automatically at the end of the setting procedure
- Acoustic charge indicator
 - 3x beeps = 20% residual charge
 - 6x beeps = 10% residual charge
 - 9x beeps = battery discharged

Scope of delivery

The FireBird® Pro comes in a new attractively designed, practical plastic case.



The quick setting guide and setting force guide in credit card format are also included in the scope of delivery.



FireBird® Pro

FireBird® Pro - The new battery powered blind rivet nut setting tool - for blind rivet nuts up to M8 steel!

FireBird® Pro

With slide-on, rechargeable 18.0 V/2.1 Ah battery pack and charger* in plastic carrying case

Part no. 152 4639

FireBird® Pro

With two slide-on, rechargeable 18.0 V/2.1 Ah battery pack and charger* in plastic carrying case

Part no. 152 4712

* Supplied with Euro plug as standard (other versions on request)

Powerful and fast

The FireBird® Pro enhances the Pro series. The setting force of 15,000 N and the well-proven brushless motor make the FireBird® Pro both powerful and fast when setting blind rivet nuts of up to M 8 steel. The FireBird® Pro is controlled solely by the setting force adjustment. The thread of the blind rivet nut is therefore optimally protected while ensuring the blind rivet nut is securely anchored in the material.

High performance

18.0 Volt rechargeable energy for flexible, cable-free use on building sites and industrial production

Safety first

- Drill-on of the blind rivet nut with reduced torque and automatic switch-off
- Triggering the setting process clearly separated from the drill-on action
- Automatic drill-out function after the end of the setting process
- Drill-off with high torque
- Sturdy, compact and shockproof tool housing



Even faster, virtually no wear

Since no wear-prone brushes are used, the motor of the FireBird® Pro has an extremely long service life, is virtually non-wearing and reliably guarantees the fastest setting frequencies.

Ergonomics

- Fatigue-free working through well balanced weight repartition and ergonomic grip
- Easy setting force adjustment

The fast one

- Simple and safe drilling of the blind rivet nuts
- Constant setting speed
- Automatic switchover from setting to drilling
- Fast and simple change system for threaded mandrels

FireBird® Pro – Battery powered blind rivet nut setting tool with 18.0 Volt Li-Ion battery

Working range

Blind rivet nuts up to M10 Aluminium, M8 steel and M6 stainless steel.

Technical data

Weight: 2.4 kg with battery
Traction power: 15,000 N
Drive: DC motor
Stroke: 10.0 mm

18.0 V/2.1 Ah (li-ion) slide-on battery pack

Part no. 145 7641

Weight: 0.4 kg
available as special accessory



Accessories

Threaded mandrel and nosepiece:

- M6 (in working position)
- M4 and M5 (in magazine)

1 hexagonal wrench

1 double open ended wrench SW 24/27

Charger for 18.0 V li-ion battery

Part no. 145 7642

Technical data

Input voltage: 100 - 240 V / 50 - 60 Hz
Output voltage: 21 V DC
Charging time: 45 to 90 minutes
Weight: 0.6 kg



Note: Equipped with Euro plug as standard (other versions on request)

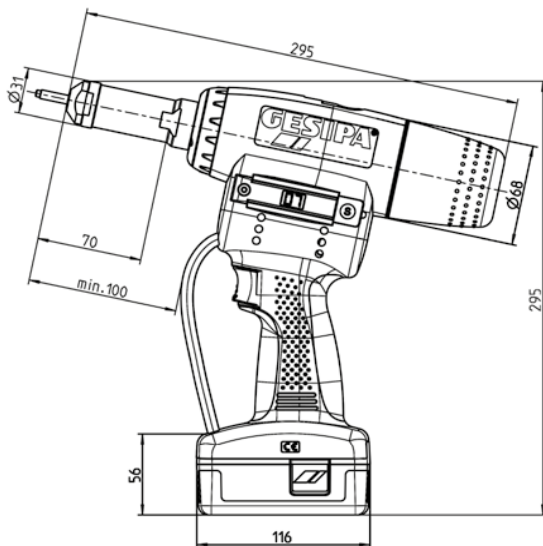

Dimensions in mm

Conversion kit for blind rivet nut studs

	Part no.	BRN thread protrusion	
		min.	max.*
M4	143 6285	8	22
M5	143 6286	9	22
M6	143 6287	10	22
M8	143 6288	12	22

Power per battery charge/Threaded mandrels and nosepieces

Blind rivet nuts inner thread	Material	approx. pc per charging process	Threaded mandrel	Nosepiece
			Part no	Part no.
M3	Alu	1,200	143 6211*	143 6218*
M3	Steel/Stainless steel	1,100		
M4	Alu	1,100	143 6212	143 6219
M4	Steel/Stainless steel	1,000		
M5	Alu	950	143 6213	143 6220
M5	Steel/Stainless steel	900		
M6	Alu	900	143 6214	143 6221
M6	Steel/Stainless steel	800		
M8	Alu	850	143 6215*	143 6222*
M8	Steel	550		
M10	Alu	750	143 6216*	143 6223*

* Available as special accessory (page 253)

FireBird® Pro Gold Edition

**FireBird® Pro Gold Edition –
The new battery powered blind
rivet nut setting tool - for blind
rivet nuts up to M12 steel!**

FireBird® Pro Gold Edition

With slide-on, rechargeable 18.0 V/2.1 Ah battery pack and charger* in plastic carrying case

Part no. 145 0841

FireBird® Pro Gold Edition

With two slide-on, rechargeable 18.0 V/2.1 Ah battery pack and charger* in plastic carrying case

Part no. 152 4713

* Supplied with Euro plug as standard (other versions on request)

Fast and even more powerful

The FireBird® Pro Gold Edition enhances the Pro series. The setting force of 20,000 N and the well-proven brushless motor make the FireBird® Pro Gold Edition both fast and even more powerful. The FireBird® Pro Gold Edition sets blind rivet nuts of up to M 12 steel. The FireBird® Pro Gold Edition is controlled solely by the setting force adjustment. The thread of the blind rivet nut is therefore optimally protected while ensuring the blind rivet nut is securely anchored in the material.

High performance

18.0 Volt rechargeable energy for flexible, cable-free use on building sites and industrial production

Safety first

- Drill-on of the blind rivet nut with reduced torque and automatic switch-off
- Triggering the setting process clearly separated from the drill-on action
- Automatic drill-out function after the end of the setting process
- Drill-off with high torque
- Sturdy, compact and shockproof tool housing



Even faster, virtually no wear

Since no wear-prone brushes are used, the motor of the FireBird® Pro has an extremely long service life, is virtually non-wearing and reliably guarantees the fastest setting frequencies.

Ergonomics

- Fatigue-free working through well balanced weight repartition and ergonomic grip
- Easy setting force adjustment

The fast one

- Simple and safe drilling of the blind rivet nuts
- Constant setting speed
- Automatic switchover from setting to drilling
- Fast and simple change system for threaded mandrels

FireBird® Pro Gold Edition – Battery powered blind rivet nut setting tool with 18.0 Volt Li-Ion battery

Working range

Blind rivet nuts up to M12 steel and M10 stainless steel.

Technical data

Weight: 2.3 kg with battery
Traction power: 20,000 N
Drive: DC motor
Stroke: 10.0 mm

18.0 V/2.1 Ah (li-ion) slide-on battery pack

Part no. 145 7641

Weight: 0.4 kg
available as special accessory



Accessories

Threaded mandrel and nosepiece:

- M6 (in working position)
 - M8 and M10 (in magazine)
- 1 hexagonal wrench
1 double open ended wrench SW 24/27

Charger for 18.0 V li-ion battery

Part no. 145 7642

Technical data

Input voltage: 100 - 240 V / 50 - 60 Hz
Output voltage: 21 V DC
Charging time: 45 to 90 minutes
Weight: 0.6 kg



Note: Equipped with Euro plug as standard (other versions on request)

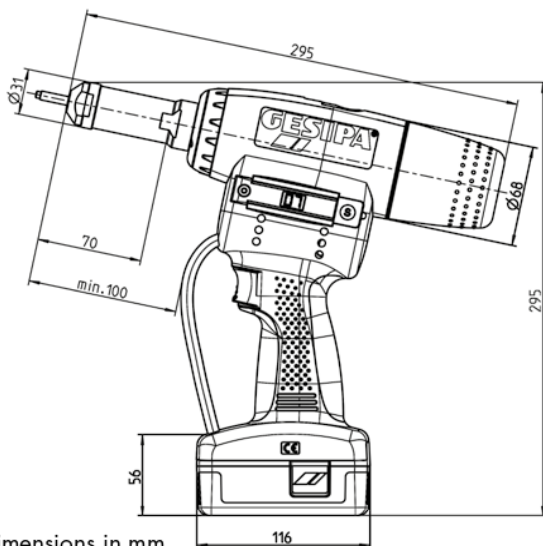

Dimensions in mm

Conversion kit for blind rivet nut studs

	Part no.	BRN thread protrusion	
		min.	max.*
M4	143 6285	8	22
M5	143 6286	9	22
M6	143 6287	10	22
M8	143 6288	12	22

Power per battery charge/Threaded mandrels and nosepieces

Blind rivet nuts inner thread	Material	approx. pc per charging process	Threaded mandrel	Nosepiece
			Part no.	Part no.
M3	Alu	1,200	143 6211*	143 6218*
M3	Steel/Stainless steel	1,100		
M4	Alu	1,100	143 6212*	143 6219*
M4	Steel/Stainless steel	1,000		
M5	Alu	950	143 6213*	143 6220*
M5	Steel/Stainless steel	900		
M6	Alu	900	143 6214	143 6221
M6	Steel/Stainless steel	800		
M8	Alu	850	143 6215	143 6222
M8	Steel	550		
M10	Alu	750	143 6216	143 6223
M10	Steel/Stainless steel	500	143 6216	143 6223
M12	Steel	300	143 6217*	143 6224*

* Available as special accessory (page 253)

FireBird®

The well-proven blind rivet nut setting tool with Li-Ion energy

FireBird® with battery 14.4 Volt / 1.3 Ah and charger, in carrying case
Part no. 145 7414

FireBird® with two batteries 14.4 Volt / 1.3 Ah and charger, in carrying case
Part no. 145 7413



High performance

14.4 Volt rechargeable energy for flexible, cable-free use on building sites and industrial production

Safety first

- Drill-on of the blind rivet nut with reduced torque and automatic switch-off
- Triggering the setting process clearly separated from the drill-on action
- Automatic drill-out function after the end of the setting process
- Drill-off with high torque
- Sturdy, compact and shockproof tool housing

Ergonomics

- Fatigue-free working through well balanced weight repartition and ergonomic grip
- Easy stroke adjustment

With Li-Ion energy

- Battery with 1.3 Ah (standard) or power battery with 2.6 Ah as special accessory
- No memory-effect
- High energy yield due to high voltage
- Low weight allows for extremely easy and fast operation
- Extremely low self discharge
- New battery shape allow the tool to be stored standing on its battery

The fast one

- Simple and safe drilling of the blind rivet nuts
- Constant setting speed
- Automatic switchover from setting to drilling
- Fast and simple change system for threaded mandrels

The versatile one

M10 alu blind rivet nuts and up to M8 steel and up to M6 stainless steel

FireBird® – Battery powered blind rivet nut setting tool with 14.4 Volt Li-Ion battery

Working range

Blind rivet nuts up to M10 aluminium,
up to M8 steel and up to M6 stainless steel

Technical data

Weight: 2.1 kg with battery
Traction power: 13,000 N
Drive: DC motor
Stroke: 5.5 mm

Accessories

Threaded mandrel and nosepiece:

- M6 (in working position)
 - M4 and M5 (in magazine)
- 1 hexagonal wrench
1 double open ended wrench SW 24/27

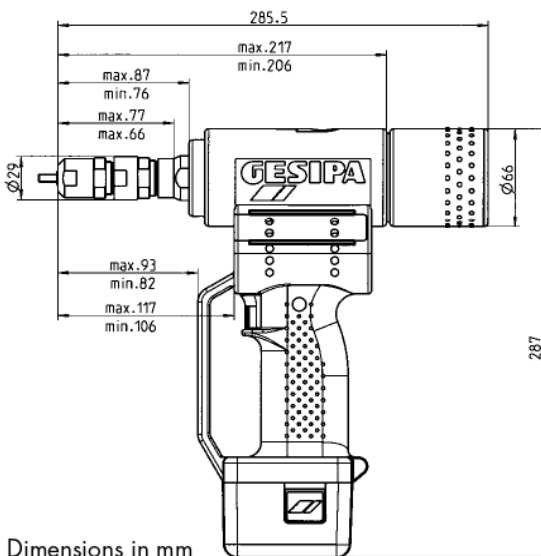

Dimensions in mm

Power per battery charge/Threaded mandrels and nosepieces

Blind rivet nuts inner thread	Material	approx. pc per charging process	Part no.	
			Threaded mandrel	Nosepiece
M3	Alu	500	143 5052*	143 5065*
M3	Steel/Stainless steel	450		
M4	Alu	450	143 5055	143 5066
M4	Steel/Stainless steel	400		
M5	Alu	350	143 5056	143 5067
M5	Steel/Stainless steel	350		
M6	Alu	350	143 5059	143 5068
M6	Steel/Stainless steel	250		
M8	Alu	300	143 5063*	143 5069*
M8	Steel	150		
M10	Alu	250	143 5064*	143 5070*

* Available as special accessory

Charger 14.4 V Li-Ion

Part no. 145 7282

Technical data

Input voltage: 230 V / 50 Hz
Output voltage: 14.4 V DC
Recharging time: 50 to 100 minutes (battery depending)
Weight: 0.6 kg



Conversion kit for blind rivet nut studs

	Part no.	BRN thread protrusion	
		min.	max.
M4	143 5117	8	22
M5	143 5118	9	22
M6	143 5119	10	22
M8	143 5121	12	22

Battery

14.4 V/1.3 Ah (Li-Ion)

Part no. 143 4921

Weight: 0.35 kg

Power battery
14.4 V/2.6 Ah (Li-Ion)

Part no. 145 7269

Weight: 0.5 kg
available as special accessory



FireBird® with blind rivet nut studs conversion kit

The blind rivet nut studs conversion kits enable the FireBird® to be used to set M4 and M8 blind rivet nut studs.

* The tool is delivered without threaded mandrels and nosepieces. Please order the corresponding conversion kit.

Basic FireBird® model
without threaded mandrels and nosepieces
with 14.4 V / 1.3 Ah quick-replacement battery and charger, in carrying case

Part no. 146 4336



Further info



Page 14

Conversion kit for blind rivet nut studs

	Part no.	BRN thread protrusion	
		min.	max.*
M4	143 5117	8	22
M5	143 5118	9	22
M6	143 5119	10	22
M8	143 5121	12	22

* A corresponding extended nosepiece must be used for thread protrusions > 22 mm.

Technical data

Weight: 2.1 kg with battery
Traction power: 13,000 N
Drive: DC motor
Stroke: 5.5 mm

Charger 14.4 V Li-Ion

Part no. 145 7282

Technical data

Input voltage: 230 V / 50 Hz
Output voltage: 14.4 V DC
Recharging time: 50 to 100 minutes
(battery depending)
Weight: 0.6 kg



Battery 14.4 V/1.3 Ah (Li-Ion)

Part no. 143 4921

Weight: 0.35 kg

Power battery 14.4 V/2.6 Ah (Li-Ion)

Part no. 145 7269

Weight: 0,5 kg
available as special accessory



FireBird® Pro and FireBird® Pro Gold Edition - accessories



Threaded mandrel and nosepiece set for blind rivet nut setting tools

Equipped with a complete set of nosepieces and threaded mandrels (M3 to M12) in a plastic carrying case. Suitable for:

- FireBird® Pro
- FireBird® Pro Gold Edition
- FireFox® 2 (all versions except FireFox® 2 C)

Metric dimensions

Part no. 145 8111

UNC/UNF dimensions

Part no. 145 8112

Conversion kit for hexagon socket screws

(FireBird® Pro and FireBird® Pro Gold Edition)

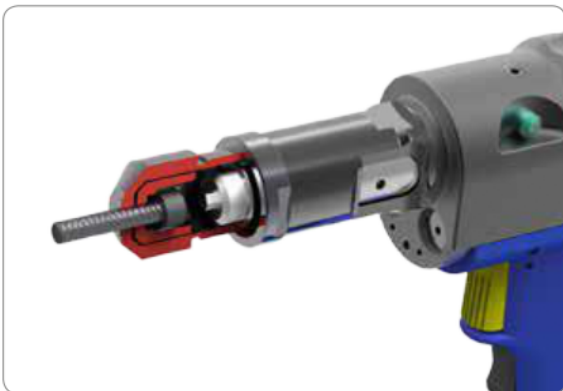

Can be operated with DIN EN ISO 4762 allen screws instead of threaded mandrels.

Special adapters available as accessory for M4 to M8 threads allows the original threaded mandrels to be replaced by allen screws: A substantial cost saving without any quality or performance loss and higher endurance when far away from the spare parts source. Best results are obtained with 12.9 grade screws.

Conversion kit for blind rivet nuts	Part no.
M4 x min. 20	143 6264
M5 x min. 25	143 6279
M6 x min. 30	143 6283
M8 x min. 30	143 6284

Conversion kit for extended DIN screws (SL30)	Part no.
M4 x min. 50	145 8182
M5 x min. 50	145 8183
M6 x min. 60	145 8184
M8* x min. 60	145 8178

Hydro-pneumatic blind rivet nut setting tools

Hydro-pneumatic blind rivet nut setting tools



255



256

FireFox® 1 F



258

FireFox® 2 F with setting force



262

FireFox® 2



264

FireFox® 2 FL



266

FireFox® 1 F with conversion kit for blind rivet nut studs



267

FireFox® 2 with conversion kit for blind rivet nut studs



268

FireFox® 1 F Axial eco



270

FireFox® 2 F Axial eco



272

FireFox® 2 F Axial eco with contact pressure monitoring and counting sensor



273

FireFox® 2 C WinTech



274

FireRex® and FireRex® 2 C WinTech



280

GBM 95

What rivets what?

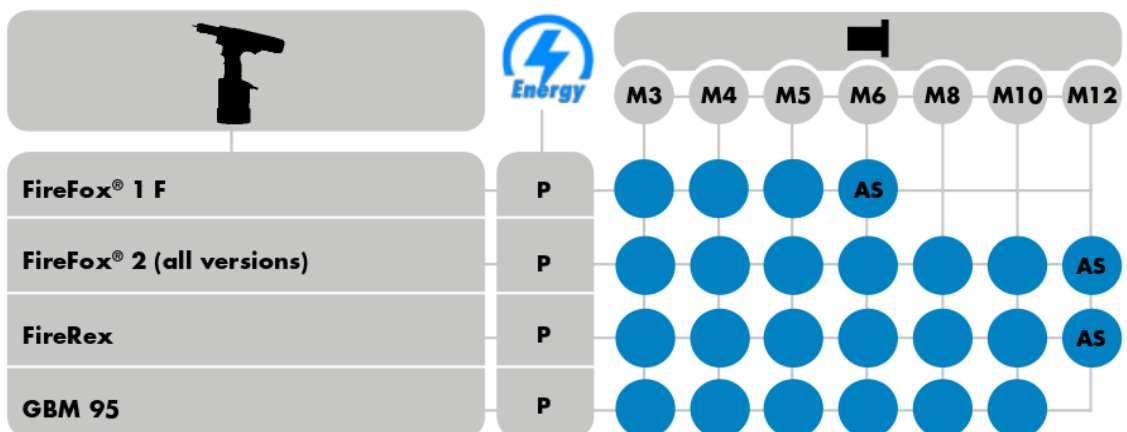

P: Hydro-pneumatic tool
A: Alu/Copper
S: Steel
E: Stainless Steel

Blue box: All materials (ASE) can be riveted. Where there are exceptions, the letters of the rivetable materials are provided directly in the box.



Technological leadership, experience and in-house production – The hydro-pneumatic blind rivet nut setting tool from GESIPA®

The FireFox® tool series – continuous product optimisation

We meet the demands of our customers with constant product optimisation.

Threaded mandrels

Supplied as standard with four commonly used threaded mandrels and nosepieces (also FireFox® 2)

Setting characteristics

New technology with improved setting characteristics (also FireFox® 2)

Noise reduction

By use of a silencer

Reduced air blast

No disruptive air flow



FireFox® 1 F

FireFox® 1 F – The hydro-pneumatique blind rivet nut setting tool for M3-M6

The easier-to-handle little brother of the FireFox® has been developed to allow even smaller blind rivet nuts to be set optimally and without damaging the materials to be joined. The **FireFox® 1 F** is controlled exclusively by setting the setting power. The thread of the blind rivet nut is perfectly protected and the blind rivet nut is anchored securing in the material being joined. Thanks to the modular system, the FireFox® 1 F has the same ergonomic design, low-fatigue working and familiar reliability of GESIPA® processing devices as its big brother. The stability has been optimised using a new rubber base.

FireFox® 1 F
Part no. 145 8198

including threaded mandrels and nosepieces M3, M4, M5, and M6 (in working position).

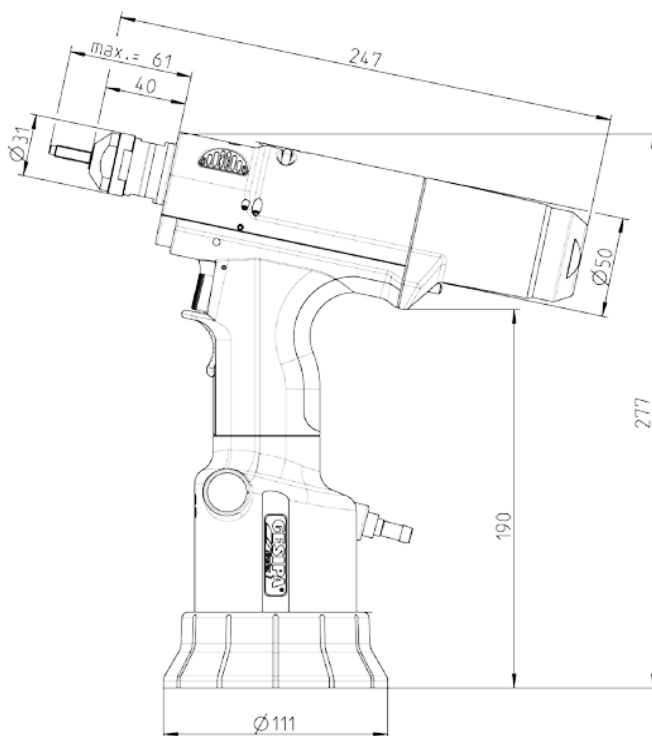

Dimensions in mm



With silencer and improved setting technology



With fast setting force presetting by using a new colour coding.

Working range

Blind rivet nuts from M3 up to M6 of all materials, except M6 stainless steel.

Technical data

Weight:	1.96 kg
Maximum stroke:	approx. 7.5 mm
Adjustable traction force:	up to approx. 12,5 kN at 6 bar
Operating air pressure:	5-7 bar
Air hose connection:	6 mm Ø (1/4")
Air consumption:	approx. 1-2 ltr. per setting process (depending on nuts size)

FireFox® 1 F – hydro-pneumatic blind rivet nut setting tool for M3-M6

Scope of delivery

2 double open ended wrenches SW 24/27
 4 threaded mandrels (M3, M4, M5, M6)
 4 nosepieces (M3, M4, M5, M6)
 1 hexagon screw driver SW 4
 1 oil refill bottle with hydraulic oil 100 ml
 1 oil refill can
 Operating instructions with spare parts list
 Rubber foot
 Quick setting guide

Accessoires

- Adapter* for use of cylinder screws with hexagon socket DIN EN ISO 4762 as threaded mandrel from M4 to M6
- Adapter for setting blind rivet screws, M4 to M6
- Nosepieces and threaded mandrels in imperial or US dimensions

* Same adapter as for FireFox® 2

Threaded mandrels

Article	Part no.
Threaded mandrel M3	143 6211
Threaded mandrel M4	143 6212
Threaded mandrel M5	143 6213
Threaded mandrel M6	143 6214

Article	Part no.
Threaded mandrel 6-32 UNC	143 6249
Threaded mandrel 8-32 UNC	143 6250
Threaded mandrel 10-24 UNC	143 6251
Threaded mandrel 10-32 UNF	143 6252

Nosepieces

Article	Part no.
Nosepiece M3	143 6218
Nosepiece M4	143 6219
Nosepiece M5	143 6220
Nosepiece M6	143 6221

Article	Part no.
Nosepiece 6-32 UNC	143 6256
Nosepiece 8-32 UNC	143 6257
Nosepiece 10-32 UNF	143 6258

FireFox® 2 F

The hydro-pneumatique blind rivet nut setting tool with pure setting force adjustment

The **FireFox® 2 F** with practical setting force adjustment sets standards in installing blind rivet nuts. Constant setting force adjustment is required especially for blind rivet nut sizes of equal or varying length (e.g. M6 x 15.5 or M6 x 18) that are to be fitted in different material thicknesses and protects the material to be joined as well as the thread, ensures secure anchoring of the blind rivet nut while providing a high degree of process reliability.

FireFox® 2 F
Part no. 145 1045

including threaded mandrels and nosepieces M4, M5, M6 (in working position) and M8.

Working range

Sets blind rivet nuts from M3 to M10 in all materials as well as M12 in aluminium and steel.

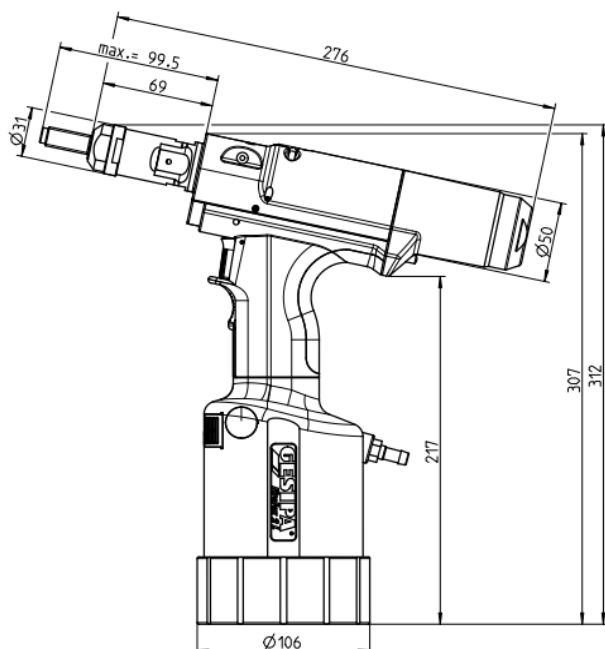

Dimensions in mm



With silencer and improved setting technology



With fast and precise setting force adjustment with colour coding visible from one side.

Technical data

Weight:	2.4 kg
Adjustable stroke, max:	10mm
Adjustable traction force, max:	22 kN at 6 bar
Operating air pressure:	5-7 bar
Air hose connection:	6 mm Ø (1/4")
Air consumption:	approx. 2 to 4 ltr. per rivet nut (depending on nut size)

Advantage

Fast and precise setting force adjustment with colour-coded setting ring

FireFox® 2 F – hydro-pneumatic blind rivet nut setting tool with pure setting force adjustment

Scope of delivery

2 double open ended wrenches SW 24/27
 4 threaded mandrels (M4, M5, M6, M8)*
 4 nosepieces (M4, M5, M6, M8)*
 1 hexagon screw driver SW 4
 1 oil refill can with hydraulic oil 100 ml
 1 oil refill can
 Operating instructions with spare parts list
 Quick setting guide

* Other threaded mandrels and nosepieces available as special accessories

Accessories

- Adapter* for use with hexagon socket cylinder screws DIN EN ISO 4762 as threaded mandrel from M4 to M8
- Adapter for setting blind rivet nut studs, M4 to M8
- Adapter for setting crimp nuts from M4 to M8
- Nosepieces and threaded mandrels in imperial or US dimensions
- Complete threaded mandrel and nosepiece sets

* Same adapter as for FireFox® 1 F

Threaded mandrels

Article	Part no.
Threaded mandrel M3	143 6211
Threaded mandrel M4	143 6212
Threaded mandrel M5	143 6213
Threaded mandrel M6	143 6214
Threaded mandrel M8	143 6215
Threaded mandrel M10	143 6216
Threaded mandrel M12	143 6217

Article	Part no.
Threaded mandrel 6-32 UNC	143 6249
Threaded mandrel 8-32 UNC	143 6250
Threaded mandrel 10-24 UNC	143 6251
Threaded mandrel 10-32 UNF	143 6252
Threaded mandrel 1/4"-20 UNC	143 6253
Threaded mandrel 5/16"-18 UNC	143 6254
Threaded mandrel 3/8"-16 UNC	143 6255

Nosepieces

Article	Part no.
Nosepiece M3	143 6218
Nosepiece M4	143 6219
Nosepiece M5	143 6220
Nosepiece M6	143 6221
Nosepiece M8	143 6222
Nosepiece M10	143 6223
Nosepiece M12	143 6224

Article	Part no.
Nosepiece 6-32 UNC	143 6256
Nosepiece 8-32 UNC	143 6257
Nosepiece 10-32 UNF	143 6258
Nosepiece 1/4"-20 UNC	143 6259
Nosepiece 5/16"-18 UNC	143 6260
Nosepiece 3/8"-16 UNC	143 6261

FireFox® 2 F – The ultimate hydro-pneumatic blind rivet nut setting tool

Most blind rivet nut setting devices are stroke-controlled, while only a few are setting force-controlled. The **FireFox® 2 F** from GESIPA® represents a new generation of blind rivet nut setting device: simply, quickly and safely.

When is setting force adjustment used?

A blind rivet nut size of the same or varying length (e.g. M6 x 15.5 or M6 x 18) should be set in changing material thicknesses using a constant setting force.

The innovative one – Setting blind rivet nuts with traction force adjustment

This means that the tool will stop pulling the blind rivet nut when a pre-adjusted traction force threshold is reached. No re-adjustment is needed when setting blind rivet nuts into different material thicknesses or when using blind rivet nuts with different shaft lengths. Traction force control prevents damage of the material which cannot be overstressed by a too high setting pressure and preserves the integrity of the blind rivet nut thread. As a bonus, it also extends the life duration of the threaded mandrels.

Fast and precise setting force adjustment with colour-coded setting ring. The required setting force is selected with a hexagon screwdriver directly on the tool.



FireFox® 2 F – The ultimate hydro-pneumatic blind rivet nut setting tool



The simple one – Easy operation through automatic drill-on function

The drill-on process will automatically start when a blind rivet nut is lightly pressed onto the mandrel tip. This avoids the cumbersome double action on twin triggers.

Thereafter introduce the blind rivet nut into its setting hole, press the trigger and keep it pressed until the setting cycle is completely finished, nut drilled off and tool free. It couldn't be easier!

The versatile one – Sets blind rivet nuts from M3 to M12, also those with extended grip range

The wide range of suitable thread sizes provides the FireFox® 2 with a large variety of possible operation. The manual traction force control also makes it suitable for industrial applications where several material thicknesses need to be covered, which would normally require the use of several tools.

Moreover, its outstanding 10 mm stroke is ideally suited to the new generation of large grip range blind rivet nuts, like the GESIPA®-PolyGrip® products.

The fast one – Extremely fast working cycle

Great care has been taken to shorten every sequence of the setting cycle to its absolute minimum: Pulling sequence and subsequent automatic drill-off take place at breathtaking speed and require only a single action on the trigger.



FireFox® 2

The hydropneumatic blind rivet nut setting tool – stroke or setting force controlled

The FireFox® 2 can be optionally controlled via the stroke or setting force setting. Especially the latter protects the material to be joined as well as the thread, ensures secure anchoring of the blind rivet nut while providing a high degree of process reliability. The choice whether stroke or setting force-controlled depends on the length of the blind rivet nut and the thickness of the material. The setting force needs to be adjusted for blind rivet nut sizes of the same or varying length in different material thicknesses. If the same blind rivet nut size and length are always set into the same material thickness, it is possible to apply a constant setting stroke.

FireFox® 2
Part no. 145 8086

including threaded mandrels and nosepieces
M4, M5, M6 (in working position) and M8.

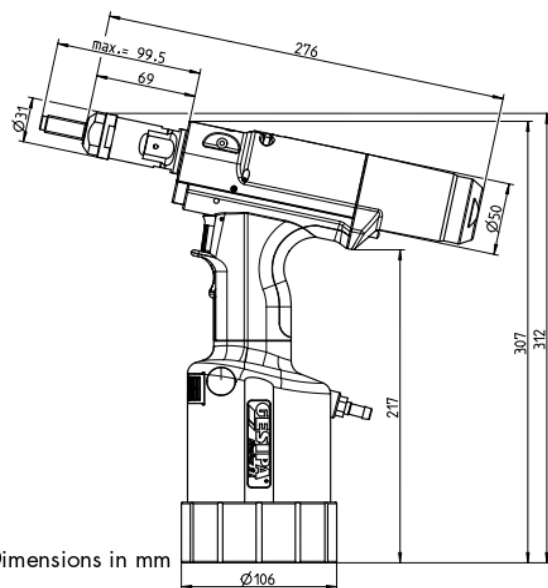

With improved setting technology

Advantages

- Fast and precise setting force adjustment with colour-coded setting ring (1)
- New stroke scale quick and easy to set even under poor light conditions
- Maximum stroke clearly identified by blue ring on stroke scale (2)
- Throttle plate: Automatic throttle for even faster and protective setting as from M3 blind rivet nuts
- PTFE (Teflon®) seal. PTFE seal and optimised pilot holes improve the service life of the slide valve

Working range

Sets blind rivet nuts from M3 to M10 in all materials as well as M12 in aluminium and steel.

Technical data

Weight:	2.4 kg
Adjustable stroke, max:	10mm
Adjustable traction force, max:	22 kN at 6 bar
Operating air pressure:	5-7 bar
Air hose connection:	6 mm Ø (1/4")
Air consumption:	approx. 2 to 4 ltr. per rivet nut (depending on)

FireFox® 2 – The hydropneumatic blind rivet nut setting tool – stroke or setting force controlled

Scope of delivery

2 double open ended wrenches SW 24/27
 4 threaded mandrels (M4, M5, M6, M8)*
 4 nosepieces (M4, M5, M6, M8)*
 1 hexagon screw driver SW 4
 1 oil refill can with hydraulic oil 100 ml
 1 oil refill can
 Operating instructions with spare parts list
 Quick setting guide

* Other threaded mandrels and nosepieces available as special accessories

Accessories

- Adapter for use with hexagon socket cylinder screws DIN EN ISO 4762 as threaded mandrel from M4 to M8
- Adapter for setting blind rivet nut studs, M4 to M8
- Adapter for setting crimp nuts from M4 to M8
- Nosepieces and threaded mandrels in imperial or US dimensions
- Complete threaded mandrel and nosepiece sets

* Same adapter as for FireFox® 1 F

Threaded mandrels

Article	Part no.
Threaded mandrel M3	143 6211
Threaded mandrel M4	143 6212
Threaded mandrel M5	143 6213
Threaded mandrel M6	143 6214
Threaded mandrel M8	143 6215
Threaded mandrel M10	143 6216
Threaded mandrel M12	143 6217

Article	Part no.
Threaded mandrel 6-32 UNC	143 6249
Threaded mandrel 8-32 UNC	143 6250
Threaded mandrel 10-24 UNC	143 6251
Threaded mandrel 10-32 UNF	143 6252
Threaded mandrel 1/4"-20 UNC	143 6253
Threaded mandrel 5/16"-18 UNC	143 6254
Threaded mandrel 3/8"-16 UNC	143 6255

Nosepieces

Article	Part no.
Nosepiece M3	143 6218
Nosepiece M4	143 6219
Nosepiece M5	143 6220
Nosepiece M6	143 6221
Nosepiece M8	143 6222
Nosepiece M10	143 6223
Nosepiece M12	143 6224

Article	Part no.
Nosepiece 6-32 UNC	143 6256
Nosepiece 8-32 UNC	143 6257
Nosepiece 10-32 UNF	143 6258
Nosepiece 1/4"-20 UNC	143 6259
Nosepiece 5/16"-18 UNC	143 6260
Nosepiece 3/8"-16 UNC	143 6261

FireFox® 2 F L

The hydro-pneumatic blind rivet nut setting tool with left-hand thread

As a version of the FireFox® 2 F, the **FireFox® 2 F L** has been specially designed for setting blind rivet nuts with left-hand thread.

Working range

M3 to M10 blind rivet nuts all materials and M12 in aluminium and steel

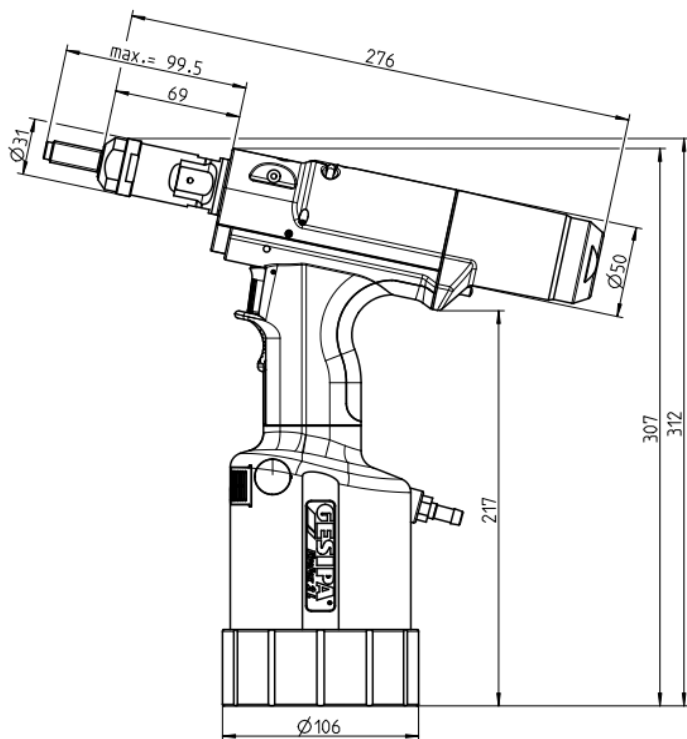

Dimensions in mm



With improved setting technology

Technical data

Weight:	2.4 kg
Adjustable stroke, max:	10 mm
Adjustable traction force, max:	22 kN at 6 bar
Operating air pressure:	5-7 bar
Air hose connection:	6 mm Ø (1/4")
Air consumption:	approx. 2 to 4 ltr. per cycle (depending on nut size)

Scope of delivery

- 2 double open ended wrenches SW 24/27
- 1 hexagon screwdriver SW 4
- 1 oil refill can with hydraulic oil 100 ml
- 1 oil refill can
- Operating instructions with spare parts list

FireFox® 2 F L – the hydro-pneumatic blind rivet nut setting tool with left-hand thread

Equipment

Threaded mandrel and nosepiece choice from M3 to M12

Accessoires

- Adapter for use with hexagon socket cylinder screws DIN EN ISO 4762 as threaded mandrel from M4 to M8
- Adapter for setting blind rivet nut studs, M4 to M8
- Adapter for setting crimp nuts from M4 to M8
- Nosepieces and threaded mandrels in imperial or US dimensions
- Complete threaded mandrel and nosepiece sets



FireFox® 2 F L – M6
Part no. 145 1037

FireFox® 2 F L – M3
Part no. 145 1034

FireFox® 2 F L – M4
Part no. 145 1035

FireFox® 2 F L – M5
Part no. 145 1036

FireFox® 2 F L – M8
Part no. 145 8098

FireFox® 2 F L – M10
Part no. 145 8099

FireFox® 2 F L – M12
Part no. 145 8100

Threaded mandrels

Description	Part no.
Threaded mandrel M3	143 6363
Threaded mandrel M4	143 6364
Threaded mandrel M5	143 6365
Threaded mandrel M6	143 6366
Threaded mandrel M8	143 6367
Threaded mandrel M10	143 6368
Threaded mandrel M12	143 6369

Nosepieces

Description	Part no.
Nosepiece M3	143 6218
Nosepiece M4	143 6219
Nosepiece M5	143 6220
Nosepiece M6	143 6221
Nosepiece M8	143 6222
Nosepiece M10	143 6223
Nosepiece M12	143 6224

FireFox® 1 F with conversion kit for blind rivet nut studs

The blind rivet stud conversion kits enable the FireFox® 1 F to be used to set M4 and M6 blind rivet studs.

* The tool is delivered without threaded mandrels and nosepieces. Please order the corresponding conversion kit.

Basic FireFox® 1 F model

Part no. 145 1106

Conversion kits for blind rivet studs

Article	Part no.	BRN thread protrusion	
		min.	max.*
M4	143 6285	8	22
M5	143 6286	9	22
M6	143 6287	10	22

* A correspondingly extended nosepiece must be used for thread protrusion > 22 mm.

Screw nosepiece for conversion kit

Description	Part no.
Screw nosepiece M4	143 5100
Screw nosepiece M5	143 5102
Screw nosepiece M6	143 5103

Screw insert for conversion kit

Description	Part no.
Screw insert M4	143 6278
Screw insert M5	143 6280
Screw insert M6	143 6281



Working range

Sets blind rivet nut studs from M4 to M6.

Technical data

Weight:	1.96 kg
Maximum stroke:	approx. 7.5 mm
Adjustable traction force:	up to approx. 12 kN at 6 bar
Operating air pressure:	5-7 bar
Air hose connection:	6 mm Ø (1/4")
Air consumption:	approx. 1-2 ltr. per setting process (depending on nuts size)

Scope of delivery

2 double open ended wrenches SW 24/27
 1 hexagon screw driver SW 4
 1 oil refill bottle with hydraulic oil 100 ml
 1 oil refill can
 Operating instructions with spare parts list
 Rubber foot
 Quick setting guide

FireFox® 2 with conversion kit for blind rivet nut studs

The blind rivet stud conversion kits enable the FireFox® 2 to be used to set M4 and M8 blind rivet studs.

* The tool is delivered without threaded mandrels and nosepieces. Please order the corresponding conversion kit.

Basic FireFox® 2 model
Part no. 145 8096

Conversion kits for blind rivet studs

Article	Part no.	BRN thread protrusion	
		min.	max. *
M4	143 6285	8	22
M5	143 6286	9	22
M6	143 6287	10	22
M8	143 6288	12	22

* A correspondingly extended nosepiece must be used for thread protrusion > 22 mm.

Screw nosepiece for conversion kit

Description	Part no.
Screw nosepiece M4	143 5100
Screw nosepiece M5	143 5102
Screw nosepiece M6	143 5103
Screw nosepiece M8	143 5105

Screw insert for conversion kit

Description	Part no.
Screw insert M4	143 6278
Screw insert M5	143 6280
Screw insert M6	143 6281
Screw insert M8	143 6282



Working range

Sets blind rivet nut studs from M4 to M8

Technical data

Weight:	2.4 kg
Adjustable stroke:	approx. 10 mm
Adjustable traction force:	up to 22 kN at 6 bar
Operating air pressure:	5-7 bar
Air hose connection:	6 mm Ø (1/4")
Air consumption:	approx. 2-4 ltr. per rivet nut (depending on nut size)

Scope of delivery

2 double open ended wrenches SW 24/27
1 hexagon screw driver SW 4
1 oil refill can with hydraulic oil 100 ml
1 oil refill can
Operating instructions with spare parts list
Quick setting guide

FireFox® 1 F Axial eco

The hydropneumatic blind rivet nut setting tool for working vertically

The FireFox® 1 F Axial eco is ideally suited for integration in production systems and facilitates flexible and ergonomically efficient manual working procedures in applications with restricted access and therefore require riveting from above.

Advantages

- Costs-effective entry model
- Ideally suited for instillation in assembly cells, fixtures or semi-automatic workstations
- Handy for processing blind rivet nuts in places that require vertical riveting action
- Can be attached to a balancer

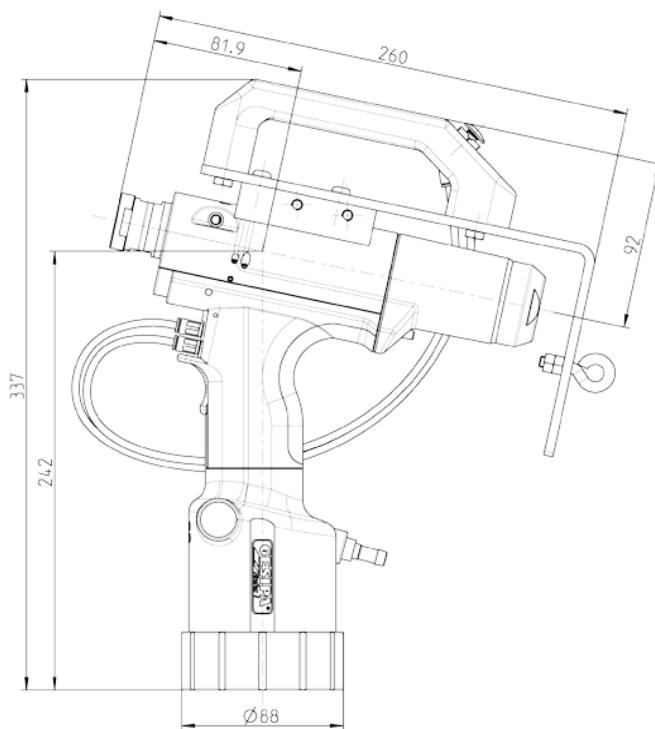

Dimensions in mm



Further info



Page 14

Working range

Sets blind rivet nuts from M3 to M6 in all materials except M6 stainless steel.

Technical data

Weight:	2.8 kg
Max. setting stroke	approx. 7.5 mm
Max. setting force, adjustable:	approx. 12 kN at 6 bar
Operating pressure:	5-7 bar
Hose connection:	6 mm Ø (1/4")
Compressed air consumption:	max. 2 l per setting (depending on nut size)

Scope of delivery

2 double open ended wrenches SW 24/27
1 hexagon screwdriver SW 4
1 oil refill can with hydraulic oil 100 ml
1 oil refill can
Operating instructions with spare parts list
Quick setting guide

FireFox® 1 F Axial eco – The hydropneumatic blind rivet nut setting tool for working vertically

Equipment

Threaded mandrel and nosepiece optional from M3 to M6.

Accessoires

- Adapter for use of cylinder screws with hexagon socket DIN EN ISO 4762 as threaded mandrel from M4 to M6
- Adapter for setting blind rivet screws, M4 to M6
- Nosepieces and threaded mandrels in imperial or US dimensions

FireFox® 1 F Axial eco – M3
Part no. 145 1103

FireFox® 1 F Axial eco – M4
Part no. 145 1104

FireFox® 1 F Axial eco – M5
Part no. 145 8199

FireFox® 1 F Axial eco – M6
Part no. 145 1105

Threaded mandrels

Article	Part no.
Threaded mandrel M3	143 6211
Threaded mandrel M4	143 6212
Threaded mandrel M5	143 6213
Threaded mandrel M6	143 6214

Article	Part no.
Threaded mandrel 6-32 UNC	143 6249
Threaded mandrel 8-32 UNC	143 6250
Threaded mandrel 10-24 UNC	143 6251
Threaded mandrel 10-32 UNF	143 6252

Nosepieces

Article	Part no.
Nosepiece M3	143 6218
Nosepiece M4	143 6219
Nosepiece M5	143 6220
Nosepiece M6	143 6221

Article	Part no.
Nosepiece 6-32 UNC	143 6256
Nosepiece 8-32 UNC	143 6257
Nosepiece 10-32 UNF	143 6258

FireFox® 2 F Axial eco

The hydropneumatic blind rivet nut setting tool for working vertically

The FireFox® Axial eco is ideally suited for integration in production systems and facilitates flexible and ergonomically efficient manual working procedures in applications with restricted access and therefore require riveting from above.

Working range

Sets blind rivet nuts from M3 to M12 in all materials except M12 stainless steel.

Technical data

Weight:	3.3 kg
Max. setting stroke:	10 mm
Drive:	Pneumatic motor
Setting force:	22 kN at 6 bar

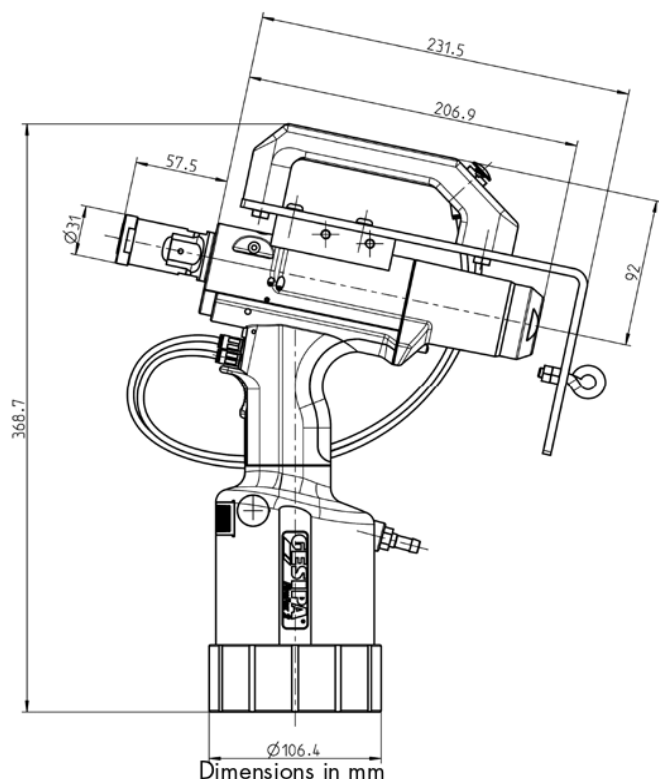

Further info



Page 14

Scope of delivery

2 double open ended wrenches SW 24/27
1 hexagon screwdriver SW 4
1 oil refill can with hydraulic oil 100 ml
1 oil refill can
Operating instructions with spare parts list
Quick setting guide

Advantages

- Costs-effective entry model
- Ideally suited for installation in assembly cells, fixtures or semi-automatic workstations
- Handy for processing blind rivet nuts in places that require vertical riveting action
- Can be attached to a balancer

FireFox® 2 F Axial eco – The hydropneumatic blind rivet nut setting tool for working vertically

Equipment

M3 to M12 threaded mandrel and nosepiece

Accessories

- Adapter for using hexagon socket head cap screws DIN EN ISO 4762 as threaded mandrel, M4 to M8
- Adapter for setting blind rivet nut studs, M4 to M8
- Nosepieces and threaded mandrels in imperial or US sizes
- Complete sets of threaded mandrels and nosepieces

FireFox® 2 F Axial eco – M3
Art.-Nr. 145 1039

FireFox® 2 F Axial eco – M4
Art.-Nr. 145 1040

FireFox® 2 F Axial eco – M5
Art.-Nr. 145 1041

FireFox® 2 F Axial eco – M6
Art.-Nr. 145 8103

FireFox® 2 F Axial eco – M8
Art.-Nr. 145 1042

FireFox® 2 F Axial eco – M10
Art.-Nr. 145 1043

FireFox® 2 F Axial eco – M12
Art.-Nr. 145 1044

Threaded mandrels

Article	Part no.
Threaded mandrel M3	143 6211
Threaded mandrel M4	143 6212
Threaded mandrel M5	143 6213
Threaded mandrel M6	143 6214
Threaded mandrel M8	143 6215
Threaded mandrel M10	143 6216
Threaded mandrel M12	143 6217

Article	Part no.
Threaded mandrel 6-32 UNC	143 6249
Threaded mandrel 8-32 UNC	143 6250
Threaded mandrel 10-24 UNC	143 6251
Threaded mandrel 10-32 UNF	143 6252
Threaded mandrel 1/4"-20 UNC	143 6253
Threaded mandrel 5/16"-18 UNC	143 6254
Threaded mandrel 3/8"-16 UNC	143 6255

Nosepieces

Article	Part no.
Nosepiece M3	143 6218
Nosepiece M4	143 6219
Nosepiece M5	143 6220
Nosepiece M6	143 6221
Nosepiece M8	143 6222
Nosepiece M10	143 6223
Nosepiece M12	143 6224

Article	Part no.
Nosepiece 6-32 UNC	143 6256
Nosepiece 8-32 UNC	143 6257
Nosepiece 10-32 UNF	143 6258
Nosepiece 1/4"-20 UNC	143 6259
Nosepiece 5/16"-18 UNC	143 6260
Nosepiece 3/8"-16 UNC	143 6261

FireFox® 2F Axial eco with contact pressure monitoring and counting sensor

With contact pressure monitoring and counting sensor – in three versions

This tool is based on the tried-and-tested FireFox® 2 F Axial eco.

Three versions are available: with contact pressure monitoring, with counting function, or with contact pressure monitoring and counting function.

The counting function is realised by an analogue oil pressure sensor and the contact pressure monitoring via an adjustable spring mechanism.

Using an analogue oil pressure sensor allows the threshold value of the oil pressure, above which the setting process is recognized as valid, to be set on a programmable logic controller (PLC) that is not part of the standard scope of delivery.

Consultation, price and delivery time on request

Advantages

- Low-price entry-level model for process monitoring
- Ideally suited for installation in assembly cells, fixtures or semi-automatic workstations
- Handy for processing blind rivet nuts in places that require vertical riveting action
- Can be attached to a balancer

Version with contact pressure monitoring and counting sensor

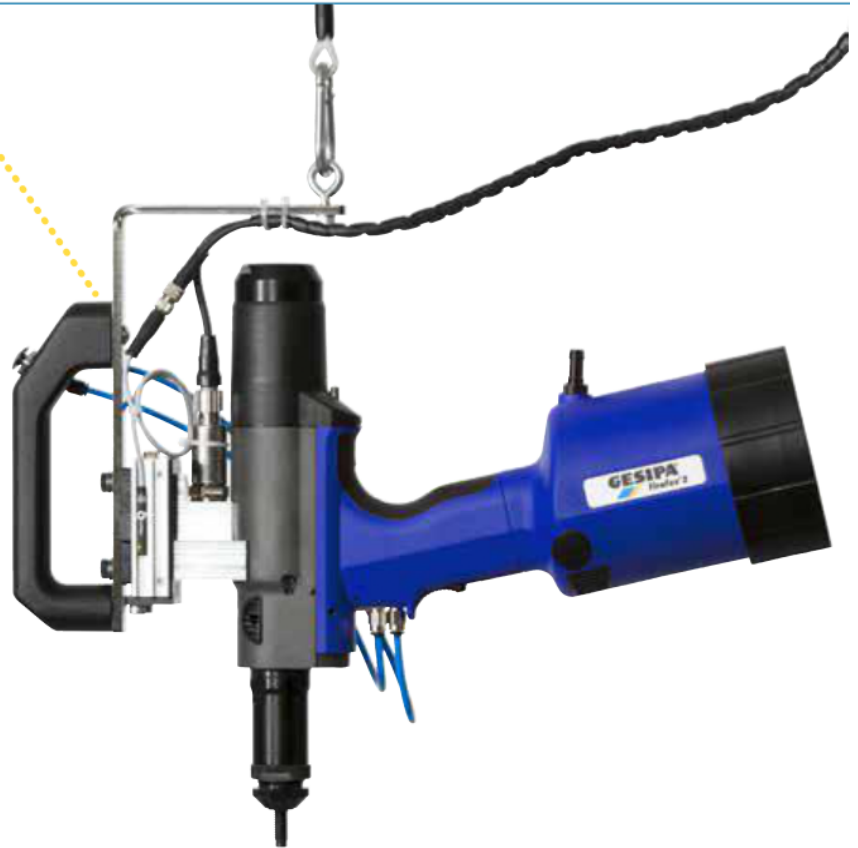

Working range

Sets blind rivet nuts from M3 to M12 in all materials except M12 stainless steel.

Technical data

Weight:	3.3 kg
Max. setting stroke:	10 mm
Drive:	Pneumatic motor
Setting force:	22 kN at 6 bar

FireFox® 2 C WinTech

FireFox® 2 C – With setting process monitoring

The FireFox® 2 C WinTech is based on the proven TAURUS® C model. Here the setting process is analysed via integrated electronics using stroke and force sensors. The user can define an OK window by means of a special software. A coloured LED on the tool shows the results of the setting process monitoring which can also be recorded and processed via data line.

Applications

In the serial production of safety component parts as well as in automated setting processes the FireFox® C allows checking and documentation of the setting process.

Advantages

- High process safety
- Documentation of each individual setting process
- Less scrap since errors can be immediately identified
- Avoidance of additional costs/quality costs due to NOK parts

NOK window

Even incompletely fitted blind rivet nuts are detected!



Advice and delivery time on request

Example of OK process

Window entry and exit at customer-defined positions

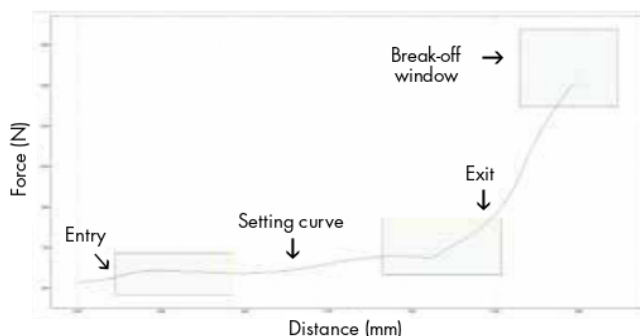

Example of not OK process

Material to be joined too thin due to missing component

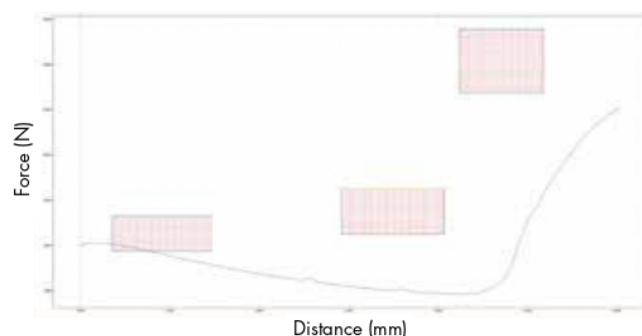

FireRex[®] and FireRex[®] 2 C WinTech

The hydropneumatic blind rivet nut setting tool with external pressure booster for greater flexibility

Now also available with setting process monitoring!

In the production of critical components as well as in automatic setting processes, the FireRex[®] 2 C WinTech can facilitate monitoring and documentation of the results. The FireRex[®] 2 C WinTech is based on the proven TAURUS[®] C model. Here the setting process is analysed via integrated electronics using stroke and force sensors. The user can define an OK window by means of a special software. A coloured LED on the tool shows the results of the setting process monitoring which can also be recorded and processed via data line.

As a further development of the tried and tested FireFox[®] 2, the FireRex[®] is capable of setting blind rivet nuts at any conceivable angle in industrial production processes. The external pressure booster makes the FireRex[®] particularly suitable for use in tight spaces. The special gun of the FireRex[®] can be integrated in production systems and facilitates flexible and ergonomically efficient manual working procedures in applications with restricted access and therefore require riveting from above.

Working range

Sets blind rivet nuts from M3 to M10 in all materials as well as M12 in aluminium and steel.

Technical data

Weight:	4.4 kg
Max. setting stroke, adjustable:	10mm
Max. setting force, adjustable:	22 kN bei 6 bar
Operating pressure:	5-7 bar
Hose connection:	6 mm Ø (1/4")
Compressed air consumption:	approx. 2 to 4 l per setting (depending on nut size)



Equipment

M5 to M12 threaded mandrel and nosepiece

Threaded mandrels and nosepieces same as for FireFox[®] 2 F, see page 259.

Advantages

- Lightweight riveting gun
- Hose connection with quick-release coupling (on request): Disconnects the gun from the external pressure booster without oil loss and without venting
- Ideally suited for setting blind rivet nuts in difficult to access places
- Also ideal for installation in assembly cells, fixtures or semi-automatic workstations
- Can be equipped with almost all FireFox[®] 2 accessories: e.g. extension units, spent mandrel container, blind rivet nut counter, setting process monitoring, spring-loaded trigger system and remote control



FireRex® as robot application



Integrated in a robot application, the FireRex® is capable of reliably setting blind rivet nuts, also hexagon, at any conceivable angle in industrial production processes. Cost-effective, innovative and fast, the new GESIPA® technology will revolutionise the industrial processing of blind rivet nuts.

Detailed information on project implementation in your company is available from our Technical Sales department on request.

FireFox® accessories



FireFox® 1 F and 2 – Flexible base

With the new flexible base made from NBR and the larger surface area, the TAURUS® tools stand even more stably.

Flexible base for FireFox® 1 F

Part no. 143 6394

Flexible base for FireFox® 2 (for all versions)

Part no. 143 6371



FireFox® 2 – protective cover

An additional **protective cover** over the head ensures that the stroke length setting is not unintentionally changed.

Protective cover

Part no. 143 6313



Swivel air connector for FireFox® 1 F & 2

(all versions except FireFox® 2 C)

Part no. 143 5479

FireFox[®] accessories



Threaded mandrel and nosepiece set for blind rivet nut setting tools

Equipped with a complete set of nosepieces and threaded mandrels (M3 to M12) in a plastic carrying case. Suitable for:

- FireBird[®] Pro
- FireBird[®] Pro Gold Edition
- FireFox[®] 2 (all versions except FireFox[®] 2 C)

Metric dimensions

Part no. 145 8111

UNC/UNF dimensions

Part no. 145 8112



Tool mount for FireFox[®] 1 F and 2

(all versions except FireFox[®] 2 C)

For integration into automated systems or connection to handling modules

Part no. 145 8175



Can only be mounted by GESIPA[®]

FireFox® accessories

FireFox® 1 and 2 – Conversion kit for blind rivet nut studs

(all versions)

Article	Part no.	BRN thread protrusion	
		min.	max.* ¹
M4	143 6285	8	22
M5	143 6286	9	22
M6	143 6287	10	22
M8* ²	143 6288	12	22

*² not FireFox® 1 F

Screw nosepiece for conversion kit

Description	Part no.
Screw nosepiece M4	143 5100
Screw nosepiece M5	143 5102
Screw nosepiece M6	143 5103
Screw nosepiece M8	143 5105

Further dimensions on request.

*¹ A correspondingly extended nosepiece must be used for thread protrusion > 22 mm.



Screw insert for conversion kit

Description	Part no.
Screw insert M4	143 6278
Screw insert M5	143 6280
Screw insert M6	143 6281
Screw insert M8	143 6282

FireFox® 1 and 2 – Conversion kit for hexagon socket screws

(all versions)

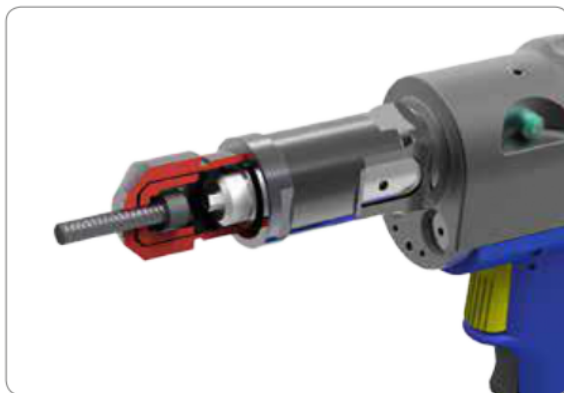

Can be operated with DIN EN ISO 4762 allen screws instead of threaded mandrels.

Special adapters available as accessory for M4 to M8 threads allows the original threaded mandrels to be replaced by allen screws: A substantial cost saving without any quality or performance loss and higher endurance when far away from the spare parts source. Best results are obtained with 12.9 grade screws

Conversion kit for blind rivet nuts	Part no.
M4 x min. 20	143 6264
M5 x min. 25	143 6279
M6 x min. 30	143 6283
M8* x min. 30	143 6284

* not FireFox® 1 F

Conversion kit for extended DIN screws (SL30)	Part no.
M4 x min. 50	145 8182
M5 x min. 50	145 8183
M6 x min. 60	145 8184
M8* x min. 60	145 8178

FireFox[®] accessories

FireFox[®] 2 – Conversion kit for crimp nuts

Installed conversion kit



Use

The conversion kits allow the use of the FireFox[®] 2 for inserting crimp nut sizes M6 to M12. This is done as fast as usual by drilling the nut on and off automatically and by fast insertion.

Delivered version

The conversion kit is delivered as a pre-assembled accessory. For inserting crimp nuts into very thick steel plates special sizes of threaded mandrels have to be used.

Installation

For installing the conversion kit special tools are not necessary. This can be done by using the wrench that comes with the FireFox[®] 2 standard version.



The conversion kit is delivered as a pre-assembled accessory.



The spring-loaded centering bush allows the setting nut to be inserted in an optimum way.

Conversion kit for setting nut	Part no.
M6	143 6354
M8	143 6355
M10	143 6356
M12	143 6357



The nut automatically drills on after having been slightly pressed onto the threaded mandrel.



Inserted nut after process has been finished.

Threaded mandrels for conversion kit

Description	Part no.
Threaded mandrel M6	143 6214
Threaded mandrel M8	143 6215
Threaded mandrel M10	143 6216
Threaded mandrel M12	143 6217

GBM 95

Working range

Blind rivet nuts from M3 up to M10
all materials

Technical data

Weight:	2.3 kg
Operating air pressure:	6 bar
Air hose connection:	6 mm Ø (1/4")
Air consumption:	ca. 8 ltr. per riveting process
Traction power:	15,700 N
Stroke:	7 mm

Accessories

- 1 wrench MSU
- 1 hexagon screwdriver SW 4
- 1 hexagonball-end driver SW 2.5
- 1 assembly rod
- 1 pin spanner Ø 42
- 1 oil refill can with hydraulic oil



Equipment

Standard: Threaded mandrel and
nosepiece (optional M3 - M10)
Operating instructions with spare parts list
Stroke table

Features

- Patented, drill-in and out system for threaded mandrels – time saving
- The compressed air used for the setting process is then used to automatically drill off the threaded mandrel – efficiently
- Simple stroke setting – safe and complete setting of the blind rivet nuts
- Setting process: Hydraulic in an axial stroke action – no twisting or turning of the blind rivet nuts and no damage to the surface
- Easy one-hand operation – rational and fatigue-proof
- Pneumatic locking of threaded mandrel – fast change without tools
- Hydraulic head; aluminium with wear-proof cylinder surface
- Pneumatic cylinder: aluminium with impact-resistance plastic sheath

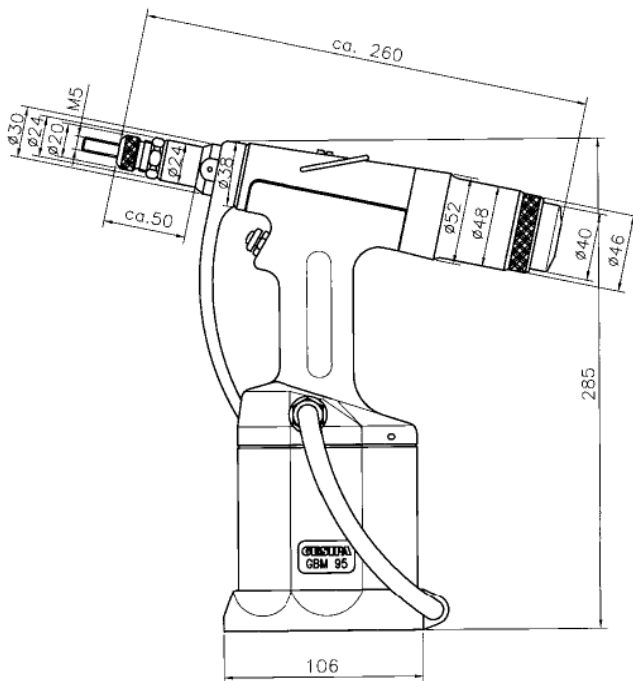

Dimensions in mm

GBM 95 – Hydro-pneumatic blind rivet nut setting tool

GBM 95 – M6
Part no. 145 7503

GBM 95 – M3
Part no. 145 7508

GBM 95 – M4
Part no. 145 7507

GBM 95 – M5
Part no. 145 7506

GBM 95 – M8
Part no. 145 7505

GBM 95 – M10
Part no. 145 7504

Threaded mandrels

Article	Part no.
Threaded mandrel M3	143 5207
Threaded mandrel M4	143 5208
Threaded mandrel M5	143 5209
Threaded mandrel M6	143 5210
Threaded mandrel M8	143 5211
Threaded mandrel M10	143 5212

Nosepieces

Article	Part no.
Nosepiece M3	143 5213
Nosepiece M4	143 5214
Nosepiece M5	143 5215
Nosepiece M6	143 5216
Nosepiece M8	143 5217
Nosepiece M10	143 5218

Conversion kit for blind rivet nut studs

Article	Part no.	BRN thread protrusion	
		min.	max.*
M4	143 5138	8	22
M5	143 5139	9	22
M6	143 5140	10	22
M8	143 5141	12	22
M10	143 5142	14	22

* A correspondingly extended nosepiece must be used for thread protrusions > 22 mm.

Screw nosepiece for conversion kit

Article	Part no.
Screw nosepiece M4	143 5135
Screw nosepiece M5	145 7520
Screw nosepiece M6	145 7521
Screw nosepiece M8	145 7523
Screw nosepiece M10	143 5136

Screw insert for conversion kit

Article	Part no.
Screw insert M4	145 7519
Screw insert M5	145 7524
Screw insert M6	145 7525
Screw insert M8	145 7526
Screw insert M10	143 5137

GESIPA®'s new products



iBird® Pro
Page 90

TAURUS® C AV
Page 146

NEW



**Flipper® Plus
Page 84**

**Protective sleeve
Page 128**

Do-it-yourself-program (DIY)

Hand riveter NTS

Part no. 143 4029

For easy setting blind rivets.

Slim design of tool body for setting rivets in narrow places, self opening spring for automatic mandrel ejection.



Service pack

Part no. 143 3668

Contents:

50 pcs. of washers 3.1 and 4.1 mm Ø and one of drills 3.1 and 4.1 mm Ø



Blind rivet nut tool GBM 5

Part no. 143 4803

Easy stroke adjustment, quick exchange of mandrel.

Working range:

Blind rivet nuts from M4 bis M6 Alu and up to M5 steel and stainless steel.



Do-it-yourself-program (DIY)

Blind rivet assortment

Part no. 143 3667

Contents:

100 blind rivets
in alu/steel:
4 mm Ø x 6, x 8, x 12



Nietboy

Part no. 143 5461

The handyman's riveting kit including
NTS hand riveter and a selection of
100 rivets, washers and a drill.



Blind rivet nut assortment

Part no. 143 3675

Contents:

Each one **threaded mandrel**
M4 and M5 for NTS and NTX.
Each 8 **blind rivet nuts M4**
short and long.
Each 8 **blind rivet nuts M5**
short and long.



Flipper®

The blind rivet hand tool for easy handling with only one hand.

Working range

Blind rivets up to 5 mm Ø aluminium and 4 mm Ø steel and stainless steel

Technical data

Weight: 750 g
Total length: 212 mm
Total stroke: 16.2 mm
Single action stroke: 1.8 mm

Nosepieces/accessories

Nosepieces: 10/18, 10/24 and 10/29
1 maintenance wrench (on magazine)
Operating instructions with spare parts list



Part no. 143 3950

Conversion kit for plastic blind rivets:

Part no. 143 3984

More about Flipper® can be found on page 82.



Part no. 143 3951

Flipper® box

Contents

Blind rivet hand tool
Flipper® and **3 PolyGrip® blind rivet sizes**, in a lightweight plastic carrying case.
Weight: approx. 0.9 kg
Dimensions: 220 x 200 x 40 mm

Incl. 3 blind rivet sizes

PolyGrip® Alu/steel	3.2 x 8.0 mm
PolyGrip® Alu/steel	4.0 x 10.0 mm
PolyGrip® Alu/steel	4.8 x 10.0 mm

Mini pack refills can be found on page 293.

Blind rivet hand tools – sortiment



Part no. 143 5457

Riveting kit

Contents

Blind rivet hand tool **NTX**
and **12 blind rivet sizes**,
1 maintenance wrench.
Weight: approx. 3.75 kg
Dimensions: 340 x 205 x 40 mm

Incl. 12 blind rivet sizes

Alu/steel	3.0 x 8.0 mm
Alu/steel	3.0 x 10.0 mm
Alu/steel	3.0 x 12.0 mm
Alu/steel	4.0 x 5.0 mm
Alu/steel	4.0 x 6.0 mm
Alu/steel	4.0 x 8.0 mm
Alu/steel	4.0 x 10.0 mm
Alu/steel	4.0 x 12.0 mm
Copper/steel	3.0 x 6.0 mm
Copper/steel	4.0 x 6.0 mm
Alu/steel	3.0 x 5.0 mm
Alu/steel	3.0 x 7.0 mm



Junior riveting kit
Part no. 143 5459

Junior riveting kit

Contents

Blind rivet hand tool **NTX**
and **5 blind rivet sizes**,
1 maintenance wrench.
Weight: approx. 2.5 kg
Dimensions:
275 x 145 x 40 mm

Incl. 5 blind rivet sizes:

Alu/steel	3.0 x 6.0 mm
Alu/steel	3.0 x 8.0 mm
Alu/steel	4.0 x 6.0 mm
Alu/steel	4.0 x 10.0 mm
Steel/steel	3.0 x 6.0 mm



Junior riveting kit PolyGrip®
Part no. 145 7662

Junior riveting PolyGrip®

Contents

Blind rivet hand tool **NTX**
and **5 PolyGrip®**
blind rivet sizes,
1 maintenance wrench.
Weight: approx. 2.5 kg
Dimensions:
275 x 145 x 40 mm

Incl. 5 PolyGrip® blind rivet sizes:

Alu/steel	3.2 x 8.0 mm
Alu/steel	4.0 x 10.0 mm
Alu/steel	4.0 x 17.0 mm
Alu/steel	4.8 x 10.0 mm
Steel/steel	4.8 x 17.0 mm

Combi setting tool Flipper® Plus



Converted in under 1 minute in just a few simple steps

1. Removal

Remove the parts shown in the image



2. Installation

Install the threaded mandrel and nosepiece



3. Converted

Converted to a blind rivet nut setting tool



One setting tool – two functions

NEW

Virtually tool-free conversion from blind rivet to blind rivet nut setting tool



Working range blind rivets

Blind rivets up to 5 mm Ø aluminium and 4 mm Ø steel and stainless steel

Working range blind rivet nuts

Blind rivet nuts from M4 up to M6 aluminium as well as from M4 up to M5 steel

Technical data

Weight:	750 g
Total length:	217 mm
Total stroke:	16.2 mm
Single action stroke:	1.8 mm

Accessories

Nosepieces: 12/20, 12/24, 12/29, 12/M4, 12/M5 and 12/M6
Threaded mandrel conversion kit: M4, M5 and M6
1 maintenance wrench, 1 Allen key
1 jaw insertion aid
Operating instructions with spare parts list

Art.-Nr. 157 1258

Shared advantages

- New ratchet function
- The force increases when the handle is closed. This finding is put to good use in a special lever arrangement for setting blind rivets and blind rivet nuts: ergonomic design
- The required manual force is reduced by around 40 percent if actuated several times.
- Actuation lever with an opening spring for easy single-handed operation

Advantages when setting blind rivets

- Jaw mechanism with spring reset for safe and automatic mandrel ejection
- Rivet mandrel collection container can be clipped to the body casing and is easy to empty
- Larger device lift: a benefit when handling extra long blind rivets

Advantages when setting blind rivet nuts

- The total stroke is 16.2 millimeter long for setting of new generation multigrip blind rivet nuts like the GESIPA® PolyGrip® blind rivet nuts
- Simplified setting procedure for blind rivet nuts

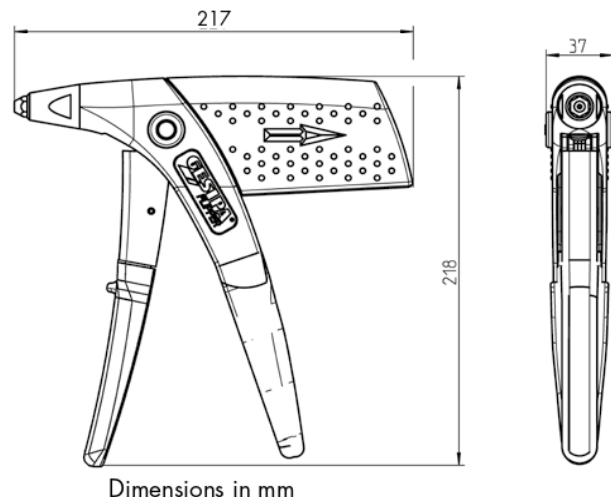

GBM 10 – Blind rivet nut hand tool

Manual blind rivet nut setting tool with simple stroke setting



Working range

Blind rivet nuts from M3* up to M6 alu and up to M5 steel, brass and stainless steel

Technical data

Weight: 600 g
Total length: 260 mm
Stroke: 7 mm

Accessories

Standard: Threaded mandrel and nosepiece (optional M4 - M6)
Maintenance instructions with spare parts list
Stroke table

*Available as special accessoires

GBM 10 – M5
Part no. 143 4761

GBM 10 – M4
Part no. 145 7087

GBM 10 – M6
Part no. 145 7088

Threaded mandrel and nosepiece allocation of GBM 10 can be found on page 235.

Blind rivet nut box

GBM 10 with threaded mandrel and nosepiece M5

including threaded mandrels and nosepieces M 4 and M 6, different blind rivet nut dimensions M 4 to M 6 made of alu for joint thicknesses of 0.25 to 3 mm.

Incl. 4 blind rivet nut sizes:

Alu M4 x 6 x 11.0 mm
Alu M5 x 7 x 11.5 mm
Alu M5 x 7 x 13.5 mm
Alu M6 x 9 x 15.5 mm



Part no. 143 5455

FireFly – Blind rivet nut hand tool

Working range

Blind rivet nuts from M3 up to M6 aluminium as well as from M3 up to M5 steel

Technical data

Total stroke: 9 mm
 Single action stroke: 1.8 mm
 Weight: 750 g

More about FireFly can be found on page 238.

FireFly box

Equipped with M5 nosepiece and threaded mandrel in plastic carrying case, with 2 mini packs alu blind rivet nuts M4 and M5 as well as nosepiece and threaded mandrel M4, operating instructions and stroke adjustment list

Part no. 143 5453

Threaded mandrel and nosepiece allocation of FireFly can be found on page 239.



Retrofit set for blind rivet nut studs

	Part no.	BRN thread protrusion	
		min.	max.*
M4	143 4009	8	22
M5	143 4010	9	22
M6	143 4011	10	22

* A corresponding extended nosepiece must be used for thread protrusions > 22 mm.

FireFly in cardboard box

Equipped with a nosepiece and threaded mandrel, operating instructions and stroke table

Article	Part no.
FireFly M5 in card-board box	143 5454
FireFly M3 in card-board box	145 7653
FireFly M4 in card-board box	145 7654
FireFly M6 in card-board box	145 7655
FireFly 6 - 32 UNC in card-board box	145 7656
FireFly 8 - 32 in card-board box	145 7657
FireFly 10 - 24 UNC in card-board box	145 7658
FireFly 10 - 32 UNF in card-board box	145 7659
FireFly 1/4" - 20 UNC in card-board box	145 7660



Mini packs

Mini pack blind rivets

18 of the most popular blind rivet sizes in **alu/steel**, **steel/steel** and **copper/bronze** in single boxes.

Alu/steel

Rivet body Ø x L in mm	Grip range mm	Part no.	pcs. per pack
3 x 6	2.5 - 3.5	143 3530	100
3 x 8	4.5 - 5.0	143 3531	100
3 x 12	7.0 - 9.0	143 3532	100
4 x 6	1.5 - 3.0	143 3533	100
4 x 8	4.0 - 5.0	143 3534	100
4 x 12	6.5 - 8.5	143 3535	100
5 x 6	2.0 - 2.5	143 3536	50
5 x 10	4.5 - 6.0	143 3537	50
5 x 12	6.0 - 8.0	143 3538	50

Copper/bronze

Rivet body Ø x L in mm	Grip range mm	Part no.	pcs. per pack
4 x 6	0.5 - 3.5	143 3662	50
4 x 10	4.5 - 6.5	143 3663	50
4 x 12	6.5 - 8.5	143 3664	50



Steel/steel

Rivet body Ø x L in mm	Grip range mm	Part no.	pcs. per pack
3 x 6	2.0 - 3.0	143 3568	100
3 x 10	5.0 - 6.5	143 3569	100
3 x 12	6.5 - 8.5	143 3570	100
4 x 6	0.5 - 2.5	143 3571	100
4 x 10	4.5 - 6.5	143 3572	100
4 x 12	6.5 - 8.5	143 3573	100

Mini pack PolyGrip® blind rivets

PolyGrip® alu/steel

Rivet body Ø x L in mm	Grip range mm	Part no.	pcs. per pack
3.2 x 8	0.5 - 5.0	143 3846	100
3.2 x 11	3.0 - 8.0	143 3847	100
4 x 10	0.5 - 6.5	143 3848	100
4 x 17	7.0 - 13.0	143 3849	50
4.8 x 10	0.5 - 6.5	143 3850	50
4.8 x 17	6.5 - 13.0	143 3851	50

PolyGrip® alu/stainless steel

Rivet body Ø x L in mm	Grip range mm	Part no.	pcs. per pack
3.2 x 8	0.5 - 5.0	146 4835	100
3.2 x 11	3.0 - 8.0	146 4834	100
4 x 10	0.5 - 6.5	146 4831	100
4 x 17	7.0 - 13.0	143 2059	50
4.8 x 10	0.5 - 6.5	146 4833	50
4.8 x 17	6.5 - 13.0	146 4832	50

Material surcharge will be added at a daily rate.

PolyGrip® alu/steel large flange K16

Rivet body Ø x L in mm	Grip range mm	Part no.	pcs. per pack
4.8 x 10	0.5 - 6.5	143 3852	25
4.8 x 17	6.5 - 13.0	143 3853	25

Large grip range:

One single PolyGrip® blind rivet can replace up to five different sizes of standard DIN blind rivets.

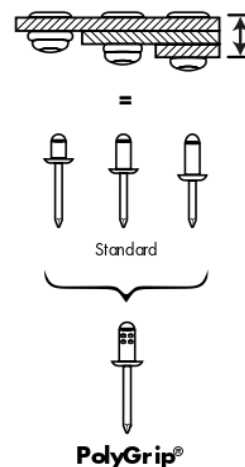

Mini packs

PolyGrip® steel/steel

Rivet body Ø x L in mm	Grip range mm	Part no.	pcs. per pack
3.2 x 8	1.0 - 5.0	146 4887	100
3.2 x 11	3.0 - 8.0	146 4886	100
4 x 10	1.5 - 6.5	146 4884	100
4 x 13	4.5 - 9.0	146 4883	50
4.8 x 10	1.5 - 6.5	143 2058	50
4.8 x 15	6.0 - 11.0	146 4885	50

PolyGrip® A2 stainless steel

Rivet body Ø x L in mm	Grip range mm	Part no.	pcs. per pack
3.2 x 8	1.0 - 5.0	143 2060	100
3.2 x 11	3.0 - 8.0	146 4830	75
4 x 10	1.0 - 6.5	146 4827	75
4 x 17	7.0 - 11.0	146 4826	50
4.8 x 10	1.0 - 6.5	146 4829	50
4.8 x 15	5.0 - 10.0	146 4828	50

Material surcharge will be added at a daily rate.

Blind rivet nuts blistered

Description	Hole-Ø mm	Grip range mm	Part no.	pcs. per pack
M4	6.1	0.25 - 3.0	143 3669	20
M4	6.1	2.5 - 4.5	143 3670	20
M5	7.1	0.25 - 3.0	143 3671	15
M5	7.1	2.5 - 5.0	143 3672	15
M6	9.1	0.25 - 3.5	143 3673	8
M6	9.1	3.0 - 5.5	143 3674	7

GBM mini pack blind rivet nuts
in **alu** on blister card.



Mini pack PolyGrip® blind rivet nuts

PolyGrip® blind rivet nut alu

Description	Hole-Ø mm	Grip range mm	Part no.	pcs. per pack
M 5	7.1	0.25 - 5.0	146 4843	50
M 6	9.1	0.25 - 6.0	146 4842	25
M 8	11.1	0.5 - 6.5	146 4841	25

PolyGrip® blind rivet nut steel

Description	Hole-Ø mm	Grip range mm	Part no.	pcs. per pack
M 5	7.1	0.25 - 5.0	146 4840	50
M 6	9.1	0.25 - 6.0	146 4839	25
M 8	11.1	0.5 - 6.5	146 4915	25

PolyGrip® blind rivet nut A2 stainless steel

Description	Hole-Ø mm	Grip range mm	Part no.	pcs. per pack
M 5	7.1	0.25 - 5.0	146 4888	50
M 6	9.1	0.25 - 6.0	146 4838	25
M 8	11.1	0.5 - 6.5	146 4837	25

Material surcharge will be added at a daily rate.

Large grip range: Ideally, the one PolyGrip® blind rivet nut can replace up to five different dimensions of DIN standard blind rivet nuts thanks to the large grip range.

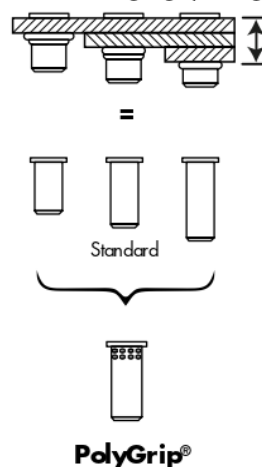

Spare parts catalogue 2018/19

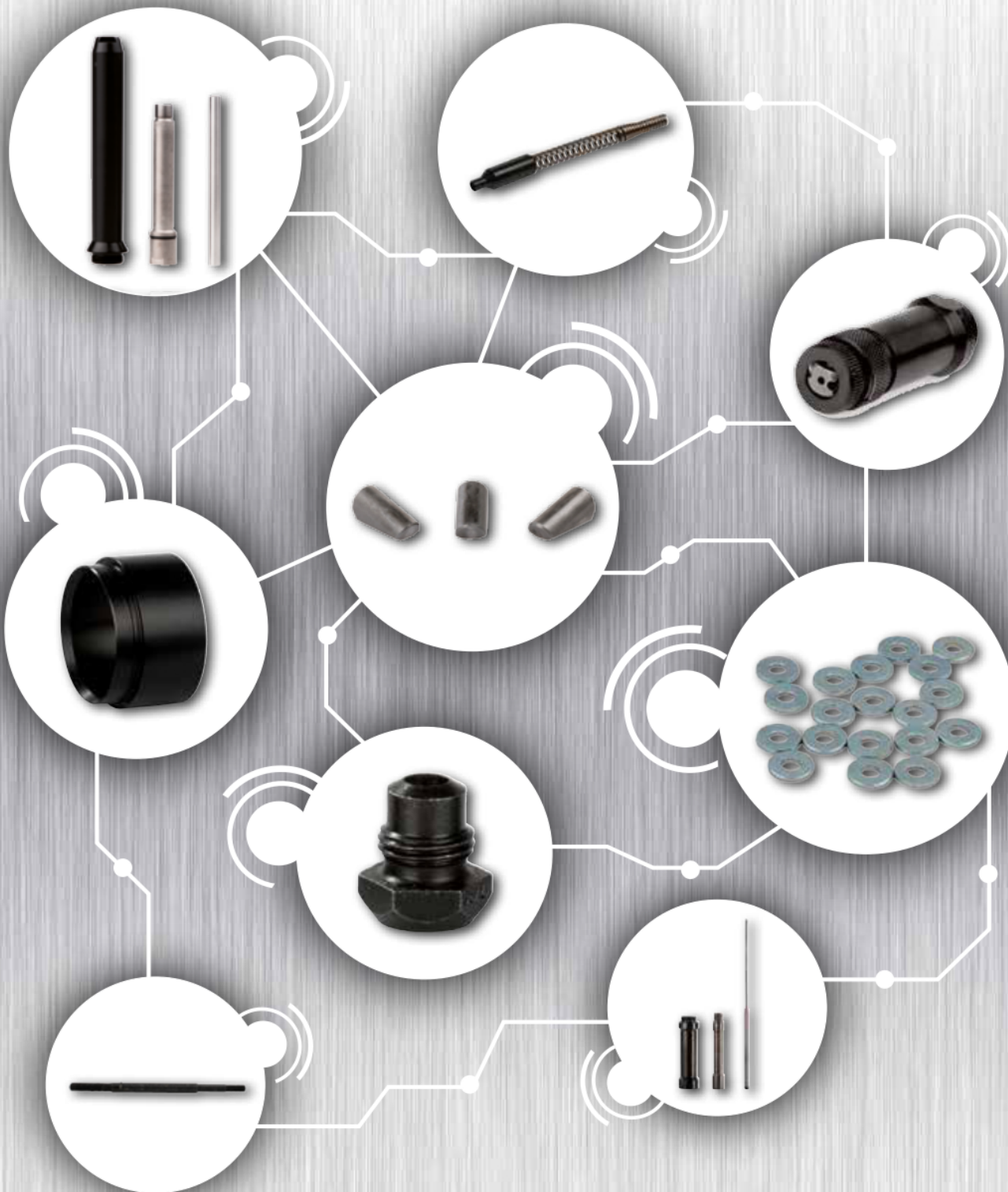

The experts in riveting technologies



Get quote 



Angic Global Solutions 1-888-872-0690
<https://www.AngicGlobal.com> Sales@AngicGlobal.com

Table of contents

Blind rivet hand tools

NTX and NTX-F; Flipper®	296
HN 2 / HN 2-BT	297
SN 2	298

Battery powered blind rivet setting tools

AccuBird®	299
AccuBird® Pro	300
PowerBird® and PowerBird® Gold Edition	301
PowerBird® Pro and PowerBird® Pro Gold Edition	302
Bird Pro series with spring-loaded trigger system	303
Spring-loaded trigger system for PowerBird®, AccuBird® and PowerBird® Angle head 90°	304

Accessories for battery powered blind rivet setting tools

One-piece extension units	305-306
Multi-piece extension units	307

Hydro-pneumatic blind rivet setting tools

TAURUS® 1-4	308-309
TAURUS® 5-6	310-311
Spring-loaded trigger system for TAURUS®	312
Repair tools, changeover set spent mandrel container, rivet counter sensor changeover set	313
Parallel head conversion kit	314-315
One-piece extension units	316-319
Multi-piece extension units	319
Heads	320
Angle heads	321-323
TAUREX 1-4	324-325
TAUREX 5-6	326-327
TAURUS® 1-4 Axial eco	328-329
TAURUS® 1-4 Axial	330-333
TAUREX Axial	334-335
Spring-loaded trigger system for TAURUS® 1-4 Axial eco	336
Spring-loaded trigger system for TAURUS® 1-4 Axial	337
TAURUS® 1-2 Speed Rivet	338-339
TAURUS® 1-2 Speed Rivet Axial eco	340-341
PH 1 and PH 2	342
PH 1-L	343
PH 2-KA	344
PH 1-VK and PH 2-VK	345
PH Axial	346
PH 2000 / PH 2000-BT	347

Special accessories for hydro-pneumatic setting tools

VAS for PH 1 und PH 2; Angle head for PH 1 und PH 2	348
Small jaw assembly	349-350
Spent mandrel container	350
Extension units	351

Nosepieces for blind rivet setting tools

Standard nosepieces	352-354
Retaining nosepiece, universal nosepiece	355
Special nosepieces	356
Plate nosepieces	357
Nosepieces for blind rivet setting tools with spring loaded trigger system	358-359

Lockbolt setting tools

TAURUS® 4 SRB with angle head 90°	360
TAURUS® 5 compact SRB	361
Head modules for lockbolt setting tools	362-363
TAURUS® 3 SRB; TAURUS® 4 SRB	364-365
PowerBird® SRB	366-367

Blind rivet hand nut setting tools

GBM 5; GBM 10	368
GBM 30	369
FireFly	370

Battery powered blind rivet nut setting tools

FireBird® and FireBird® Gold Edition	371
FireBird® Pro and FireBird® Pro Gold Edition	372-373

Hydro-pneumatic blind rivet nut setting tools

FireFox® 1 F	374-375
FireFox® 2	376-377
FireFox® 2 F; FireFox® 2 F L	378-379
FireFox® 1 F Axial eco	380-381
FireFox® 2 F Axial eco	382-383
Repair tools	384
GBM 95	385

Spare part kits

Blind rivet setting tools	386-387
Blind rivet nut setting tools	388-389

Blind rivet hand tools

NTX and NTX-F (with self opening spring)

Spare part no.	Article no.	Designation
1	145 6624	Tool housing with sleeve grip no. 15
1 F	145 6626	Tool housing with sleeve grip no. 15
2	145 6625	Tool shanks with sleeve grip no. 16
2 F	145 6627	Tool shanks with sleeve grip no. 16
4	143 4070	Jaw housing
5 •	143 4071	Jaws (2-part)
5a •	143 4241	Hard jaws (2-part) for CAP® blind rivets
6 •	143 4072	Jaw pusher
7 •	144 5258	Compression spring
7 F •	144 5260	Compression spring
8	143 4073	Closure screw
9	143 4074	Lever
10/18 •	143 4055	Nosepiece
10/24 •	143 4061	Nosepiece
10/27 •	143 4062	Nosepiece
10/32 •	143 4065	Nosepiece
12	143 4075	Bolt
13	143 4076	Bolt
14	144 5259	Snap ring
15	150 9066	Sleeve grip for tool housing no. 1
16	150 9068	Sleeve grip for tool shank no. 2
17	143 4079	Maintenance wrench SW 10
20 F •	144 5261	Self opening spring
21 F	143 4095	Strap

• Wearing parts

You will find detailed nosepiece allocation tables on page 352.

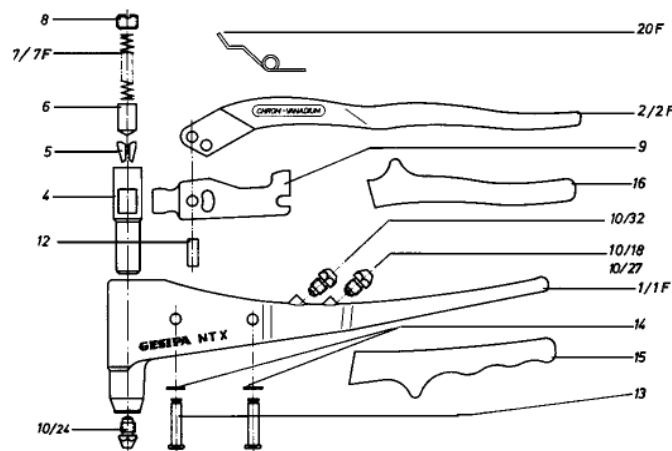

Flipper®

Spare part no.	Article no.	Designation
1	143 3963	Housing with slide block, lever and grip
2	143 3967	Pivot bolt
3	143 3968	Snap ring
4	143 3964	Sleeve grip for housing no. 1
5	143 3976	Bolt
6	143 3974	Drive pawl
7	143 3979	Spring dowel sleeve
8	143 3977	Self opening spring
9	143 3973	Sleeve grip for operating lever no. 11
10/18 •	143 4055	Nosepiece
10/24 •	143 4061	Nosepiece
10/29 •	143 4064	Nosepiece
11	145 6591	Operating lever with sleeve grip
12	143 3978	Retaining spring
13	143 3975	Storage finger (3-part) per set
14	143 3965	Head
15	143 3981	O-ring for jaw housing no. 16
16	145 6590	Jaw housing with O-ring
17 •	143 4071	Jaws (2-part) per set
18 •	143 3970	Jaw pusher
19	143 3972	Return spring
20	143 3969	Lock activator
21 •	143 3971	Compression spring
22	145 6592	Spent mandrel container with maintenance wrench
23	143 3980	Maintenance wrench SW 10
24	143 3966	Closure screw

• Wearing parts

You will find detailed nosepiece allocation tables on page 352.

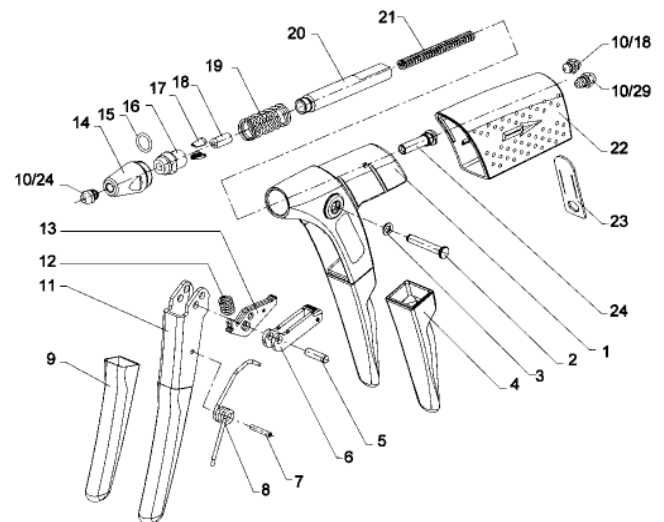

Changeover set for plastic blind rivets

Spare part no.	Article no.	Designation
10/30 K •	143 4092	Nosepiece
10/35 K •	143 4093	Nosepiece
10/40 K •	143 4094	Nosepiece
17 K •	143 4086	Jaws (2-part) per set
18 K	143 3982	Jaw pusher
24 K	143 3983	Closure screw
	143 3984	Changeover set complete

• Wearing parts

Blind rivet hand tools

HN 2 / HN 2-BT (only for BULB-TITE®)

Spare part no.	Article no.	Designation
1	145 6717	Housing with, lever and grip
3	145 6718	Operating lever with pinion and grip
4	143 4124	Grip
6	143 4125	Transmission segment
8	143 4126	Gear rack
9	143 4127	Bolt
10	143 4128	Safety bolt
11	143 4106	Jaw pusher
12 •	143 4129	Jaw housing
13 •	144 5263	Compression spring
15 •	143 4103	Jaws (3-part) per set
16/29 •	143 4290	Nosepiece
16/32 •	143 4291	Nosepiece
16/36 •	143 4292	Nosepiece
16/40 •	143 4293	Nosepiece
16/45 •	143 4300	Nosepiece
19	145 6719	End block with guide tube
20	145 6720	Spent mandrel container
23	143 4105	Head
25	144 5264	Cylinder pin
176	143 4311	Universal wrench MSU
30	145 6721	Changeover set for BULB-TITE®
16/26 BT •	143 4301	Nosepiece for 4 mm Ø BULB-TITE® rivets
16/32 BT •	143 4302	Nosepiece for 5.2 mm Ø BULB-TITE® rivets
16/42 BT •	143 4303	Nosepiece for 6.3 mm Ø BULB-TITE® rivets
16/31 MG •	143 4380	Nosepiece for 4.8 mm Ø MEGAGRIP® rivets
16/41 MG •	143 4381	Nosepiece for 6.4 mm Ø MEGAGRIP® rivets
106/14 •	143 4173	Jaws for BT and MG rivets

• Wearing parts

You will find detailed nosepiece allocation tables on page 353.

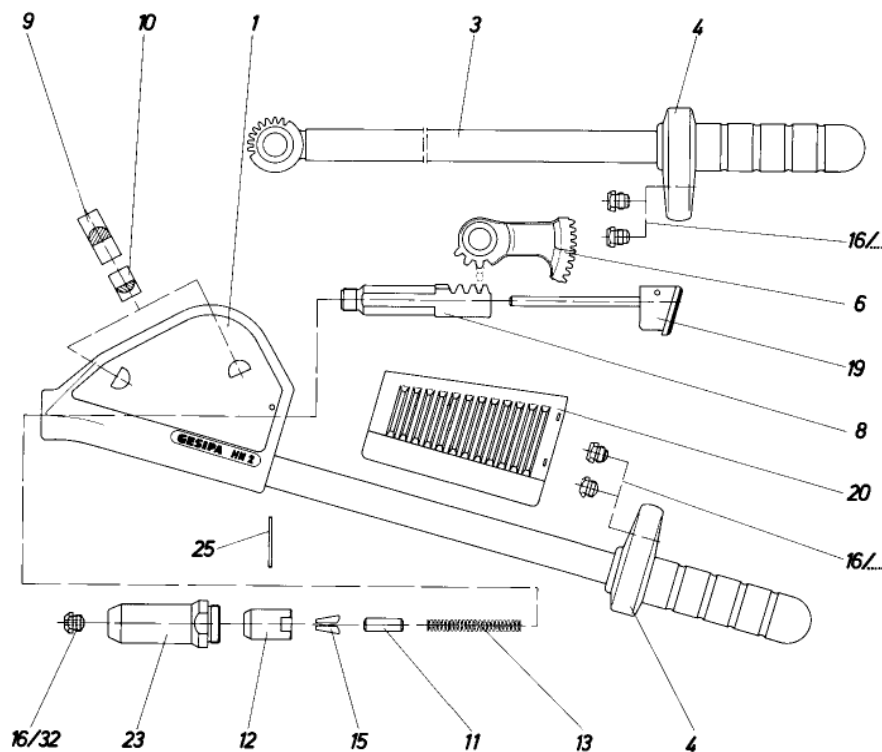

Blind rivet hand tools

SN 2 (up to April 2010)

Spare part no.	Article no.	Designation
1	145 6676	Housing
2	145 6677	Grip
3	712 2039	Lazy tongue
5	145 6678	Spacer ring
10	145 6679	Lock activator
11	143 4106	Jaw pusher
12	143 4102	Jaw housing
13 •	145 6680	Compression spring
15 •	143 4103	Jaws (3-part) per set
16/29 •	143 4290	Nosepiece
16/32 •	143 4291	Nosepiece
16/36 •	143 4292	Nosepiece
16/40 •	143 4293	Nosepiece
16/45 •	143 4300	Nosepiece
20	145 6681	Arm
21	145 6682	Slide block
23	143 4105	Head
30 a	145 6683	Bolt
30 b	145 6684	Bolt
30 c	145 6685	Bolt
32	145 6686	Snap ring
176	143 4311	Universal wrench MSU

• Wearing parts

You will find detailed nosepiece allocation tables on page 353.

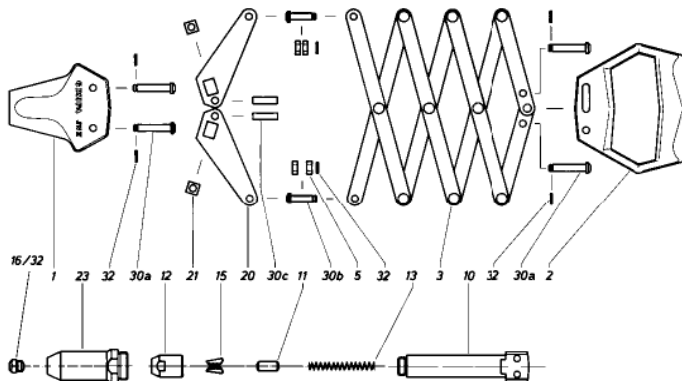

SN 2 (from May 2010)

Spare part no.	Article no.	Designation
1	145 6687	Housing
2	145 6688	Head
3	145 6689	Jaw housing
4 •	143 4958	Jaws (3-part)
5 •	145 6690	Jaw pusher
6 •	145 6691	Compression spring
7	145 6692	Locking nut
8	145 6693	Lock activator
10	145 6694	Sleeve, long
11	145 6695	Arm
12	145 6696	Lazy tongue segment, long
13	145 6697	Lazy tongue segment, short
14	145 6698	Grip
15	145 6699	Bolt
16	145 6700	Screw M6 x 37
17	145 6701	Screw M6 x 29
18	145 6702	Screw M5 x 29
19	145 6703	Screw M5 x 20.5
20	145 6704	Outer sleeve
21	145 6705	Inner sleeve
22	145 6706	Washer 6 x 1.8
23	145 6707	Washer 5 x 1.8
24	145 6708	Washer 6 x 12 x 1.0
25	145 6709	Washer 5 x 0.9
26	145 6710	Washer 5 x 0.5
27	144 5262	Nut M6
28	145 0574	Snap ring
29	145 6711	Nut M5
30	145 6712	Washer 6 x 9 x 0.7
31	145 6713	Washer 6 x 0.5
32 •	143 4955	Nosepiece 17/24
33 •	143 4973	Nosepiece 17/27
34 •	143 4974	Nosepiece 17/29
35 •	143 4975	Nosepiece 17/32
36 •	143 4977	Nosepiece 17/36
37 •	143 4999	Nosepiece 17/40
38 •	143 4860	Nosepiece 17/45

• Wearing parts

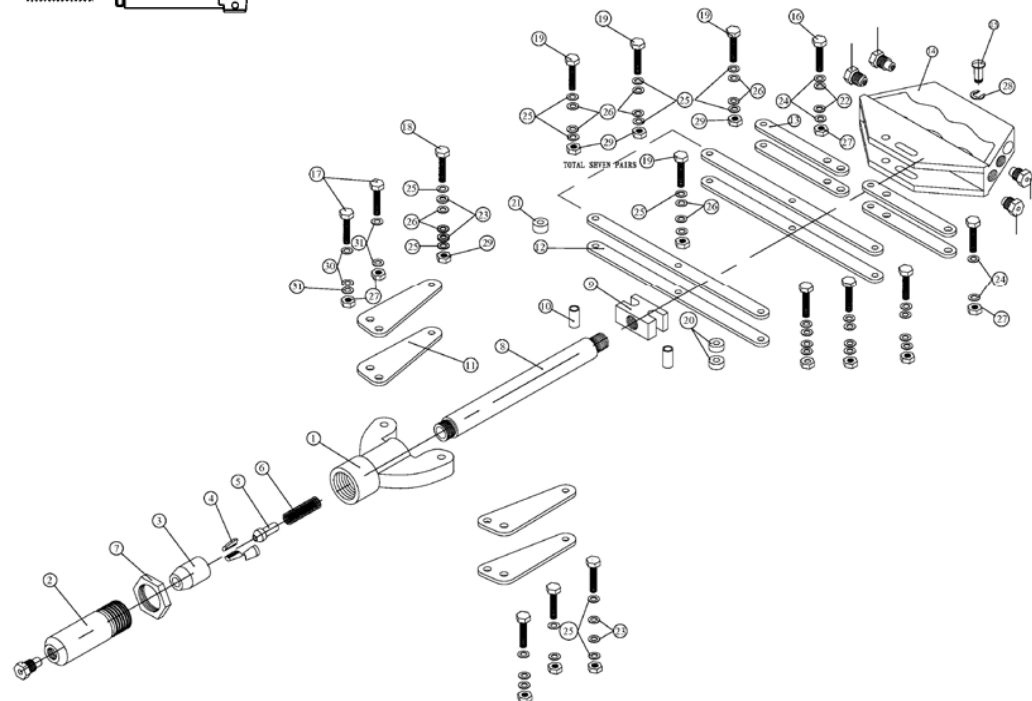

Battery powered blind rivet setting tools

AccuBird®

Spare part no.	Article no.	Designation
1 •	143 4955	Nosepiece 17/24
	143 4973	Nosepiece 17/27
	143 4974	Nosepiece 17/29
	143 4975	Nosepiece 17/32
2	143 4956	Head
3 •	143 4129	Jaw housing
	143 4958	Jaws (3-part)
4 •	143 4173	Jaws (3-part) BT
	143 4959	Jaw pusher
5 •	143 4992	Jaw pusher BT
	6 •	144 5314
7	143 4966	Wiper
8	143 4957	Adapter
9	144 5768	Allen screw
10	143 5027	Bearing, complete
11	145 7363	Ballscrew drive, mounted
12	143 4967	Stop disc
13	143 5028	Pinion shaft, complete
14	145 7361	Drive, complete (Items 1-13)
15	143 4952	Plastic tube

Spare part no.	Article no.	Designation
16	144 5763	Sintered-metal bushing
17	143 5031	Magnetic holder, complete
18	144 5770	Spring washer
19	144 5769	Magnetic holder screw
20	146 2906	E-control
21	144 5774	Hose, silicone
22 •	143 5030	Motor, complete
23	144 5773	Housing screw, short
24	144 5772	Housing screw, long
25	145 7364	Housing, complete
26	143 5017	Hanger
27	143 5016	Nosepiece magazine
28	143 4978	Magazine insert
29	144 5760	Key
30	143 4953	Protection bracket
31	143 5032	Spent mandrel container, complete
32	143 5034	Extension
	143 5033	Changeover set for BULB-TITE® (BT), complete
	146 2907	Safety lubricating grease, 40g tube

• Wearing parts

* for BULB-TITE® blind rivets

You will find detailed nosepiece allocation tables on page 354.

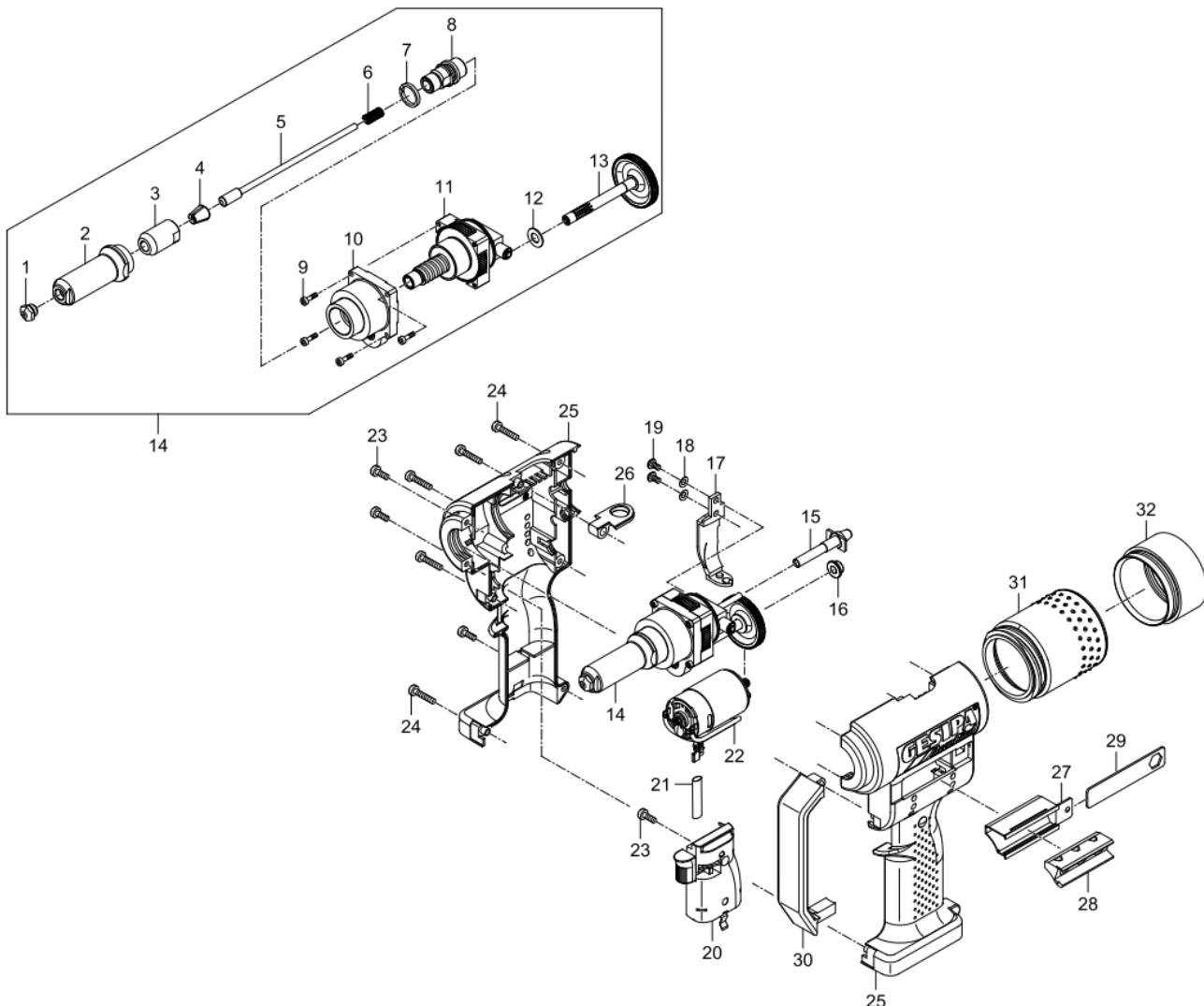

Battery powered blind rivet setting tools

AccuBird® Pro

Spare part no.	Article no.	Designation
1 •	143 4955	Nosepiece 17/24
	143 4973	Nosepiece 17/27
	143 4974	Nosepiece 17/29
	143 4975	Nosepiece 17/32
2	143 6003	Steel head sleeve
3 •	144 6012	O-ring
4 •	143 5392	Jaw housing
5 •	143 5568	Jaws (3-part)
6 •	143 5448	Jaw pusher
7 •	143 5412	Spring
8	143 5413	Connector
9	143 5414	Threaded bush
10	143 5445	Spring
11	143 5386	Adapter
12	144 5768	Screw
13	143 5398	Bearing, complete
14	143 5406	Ball screw drive
15	143 4962	Washer
16	143 5397	Bearing cage, complete
17	143 5385	Pin
18	143 4970	Sintered metal roller
19	144 5790	Lock washer
20	145 0817	Magnet
21 •	143 5393	Channel tube
22	144 5990	Screw
23 •	143 4874	Tube, short
24	143 5449	Pinion shaft
25	143 4967	Washer

Spare part no.	Article no.	Designation
26	145 0856	Drive unit, complete (1-25)
27	144 5763	Sintered-metal bushing
28	143 5408	Plate
29	144 5989	Screw
30	145 0857	Motor, complete
31	143 5451	Control
32	144 5773	Screw, short
33	144 5987	Screw
34	144 5772	Screw, long
35	143 5401	Housing, complete
36	143 5017	Hanger
37	143 5403	Cable duct
38	143 5016	Nosepiece magazine
39	143 4978	Magazine insert
40	145 0858	Power Bird Pro key, complete
41	143 5399	Tool bar
42	143 5396	Spent mandrel container, complete
43	145 7644	Light, complete
44 •	145 7641	Battery
45	145 7642	Battery charger (EU)
	145 7649	Battery charger (USA)

• Wearing parts
You will find detailed nosepiece allocation tables on page 354.

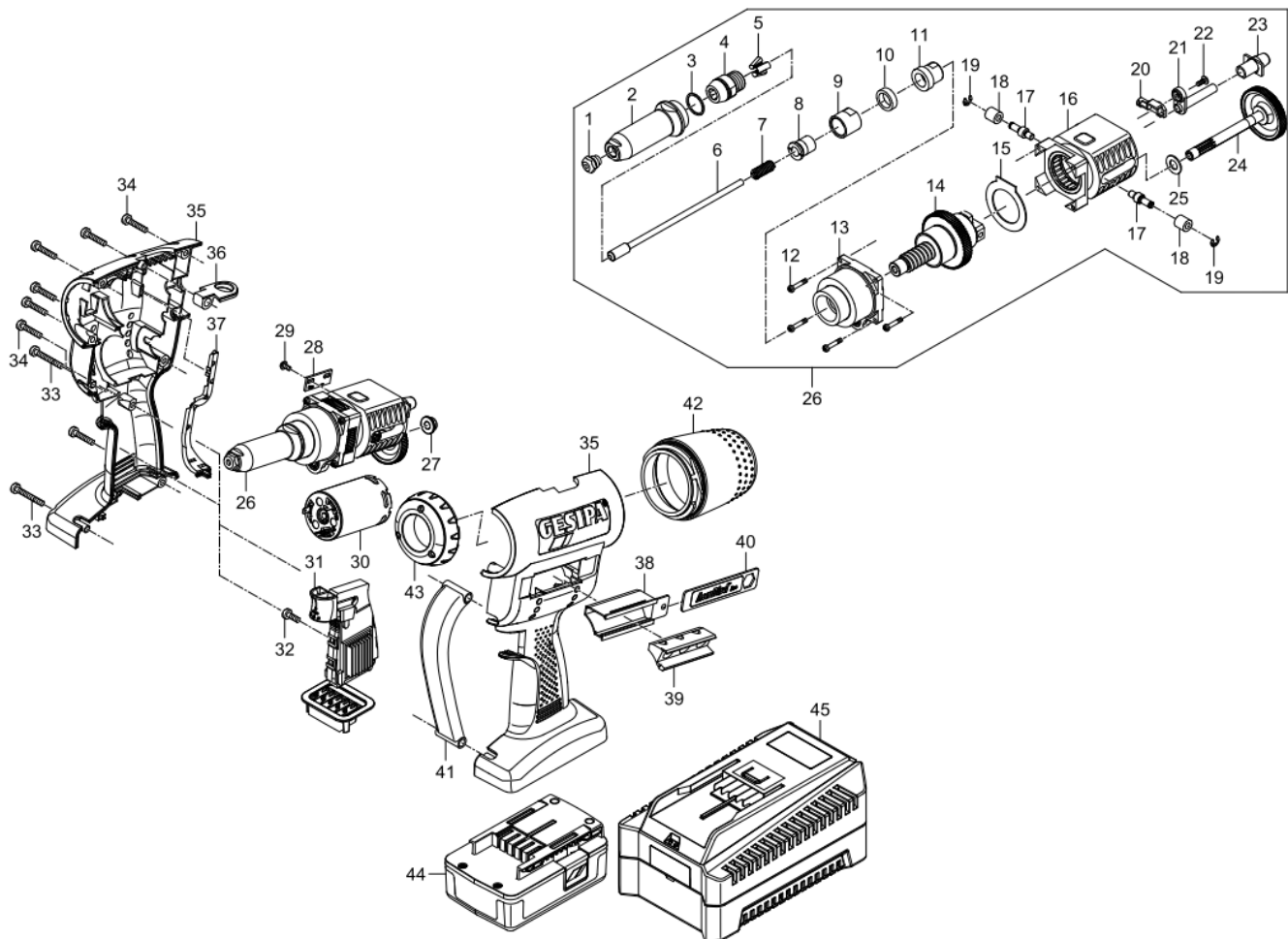

Battery powered blind rivet setting tools

PowerBird® and PowerBird® Gold Edition* – *tool no longer available

Spare part no.	Article no.	Designation
1 •	143 4975	Nosepiece 17/32
	143 4977	Nosepiece 17/36
	143 4999	Nosepiece 17/40
	143 4860	Nosepiece 17/45
2	143 4956	Head
3	143 4129	Jaw housing
	143 4104	Jaws (3-part)
4 •	143 4173	Jaws for 17/48 BT*
	143 4240	Jaws for 106/14 MG
	143 4861	Jaw pusher (for BN > Ø 5)
5 •	143 4872	Jaw pusher
	144 5747	Compression spring
7	143 4966	Wiper
8	143 4864	Adapter
9	144 5768	Allen screw
10	143 5027	Bearing, complete
11	143 4867	Ballscrew drive, mounted
12	143 4967	Stop disc
13	143 5028	Pinion shaft, complete
14	145 7228	Drive complete (1-13)
15	143 4871	PB tube
16	143 4873	Angle
17	143 4874	P tube, short
18	144 5763	Sintered-metal bushing
19	143 5031	Magnetic holder, complete

Spare part no.	Article no.	Designation
20	144 5769	Magnetic holder screw
21	146 2904	E-control
	143 4835	E-control for Gold Edition
22	144 5774	Hose, silicone
23 •	143 4862	Motor, complete
24	144 5773	Housing screw, short
25	144 5772	Housing screw, long
26	143 4845	Housing, complete
27	143 5017	Hanger
	144 5746	Hanger, Gold Edition
28	143 5016	Nosepiece magazine
29	143 4978	Magazine insert
30	144 5760	Key
31	143 4953	Protection bracket
32	143 5032	Spent mandrel container, complete
	143 4851	Spent mandrel container, complete for Gold Edition
33	143 5034	Extension
	146 2907	Safety lubrication grease 40 g tube

• Wearing parts
 * for BULB-TITE® Blind rivets
 ** for MEGA GRIP® Blind rivets
 You will find detailed nosepiece allocation tables on page 354.

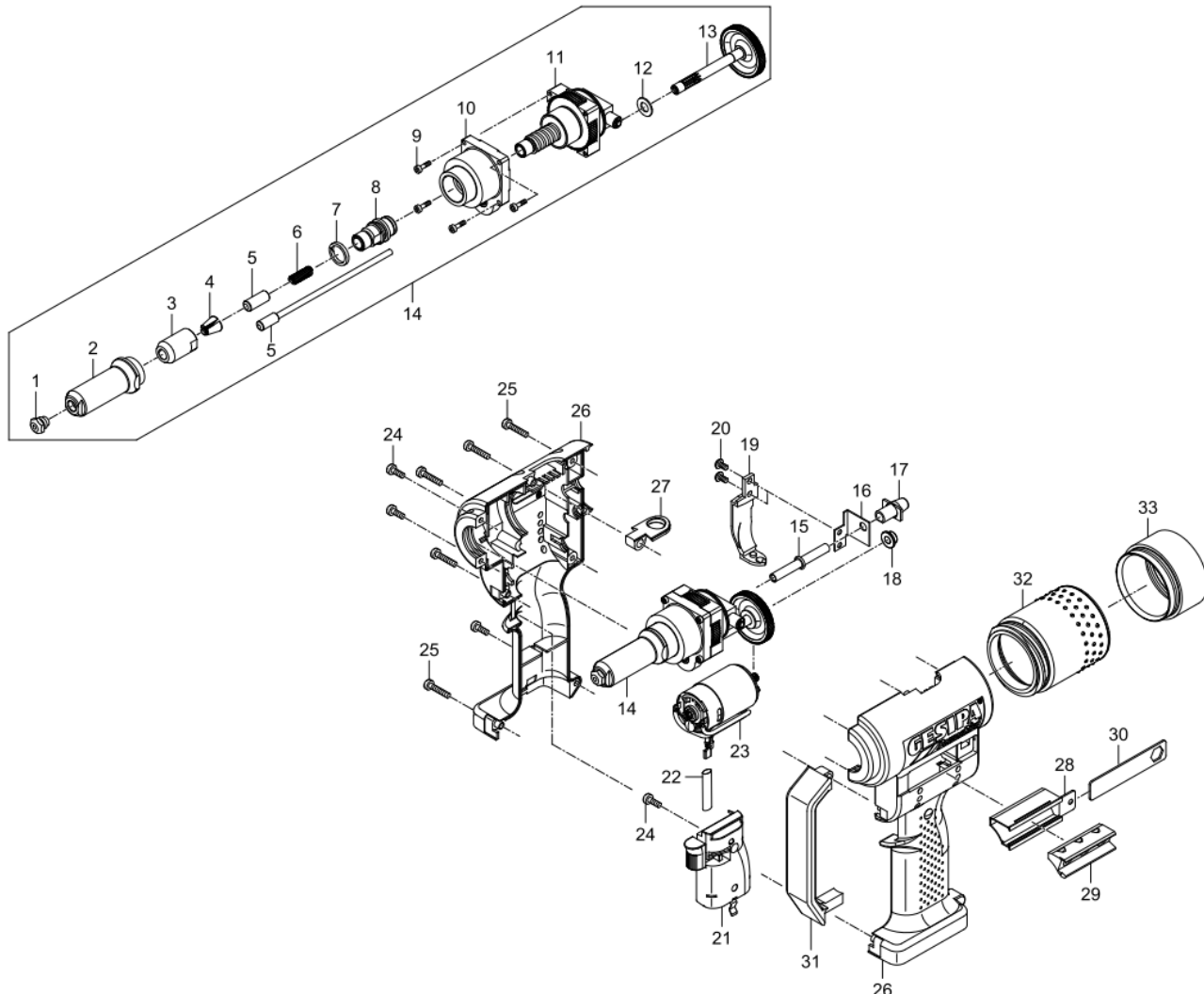

Battery powered blind rivet setting tools

PowerBird® Pro and PowerBird® Pro Gold Edition

Spare part no.	Article no.	Designation
1 •	143 4975	Nosepiece 17/32
	143 4977	Nosepiece 17/36
	143 4999	Nosepiece 17/40
	143 4860	Nosepiece 17/45
2	143 6003	Steel head sleeve
3 •	144 6012	O-ring
4 •	143 5392	Jaw housing
5 •	143 5568	Jaws (3-part)
6 •	143 5384	Jaw Pusher (> Ø 5)
7 •	143 5448	Jaw Pusher (< Ø 5)
8 •	143 5412	Spring
9	152 0557	Adapter
10	144 5768	Screw
11	143 5398	Bearing, complete
12	143 5406	Ball screw drive
13	143 4962	Washer
14	143 5397	Bearing cage
15	143 5385	Pin
16	143 4970	Sintered metal roller
17	144 5790	Lock washer
18	145 0817	Magnetic holder
19 •	143 5393	Channel tube
20	144 5990	Screw
21 •	143 4874	Tube
22	143 5442	Pinion shaft
	143 5395	Pinion shaft Pro Gold Edition
23	143 4967	Washer

Spare part no.	Article no.	Designation
24	143 2608	Drive unit Pro complete
	145 7643	Drive unit Pro GE complete
25	144 5763	Sintered-metal bushing
26	144 5989	Screw
27	143 5408	Plate
28	146 3584	Motor complete Pro
	145 7645	Motor complete Pro Gold Edition
29	143 5441	Control Pro
	143 5381	Control Pro Gold Edition
30	144 5773	Screw, short
31	144 5987	Screw
32	144 5772	Screw, long
33	143 5401	Housing, complete
34	143 5416	Hanger Pro
	144 5746	Hanger Pro Gold Edition
35	143 5403	Cable duct
36	143 5016	Nosepiece magazine
37	143 4978	Magazine insert
38	145 7646	Key PowerBird® Pro complete
39	143 5399	Tool bar
40	143 5396	Spent mandrel container, complete
41	145 7644	Light, complete
42 •	145 7641	Battery
43	145 7642	Battery charger (EU)
	145 7649	Battery charger (USA)

• Wearing parts
You will find detailed nosepiece allocation tables on page 354.

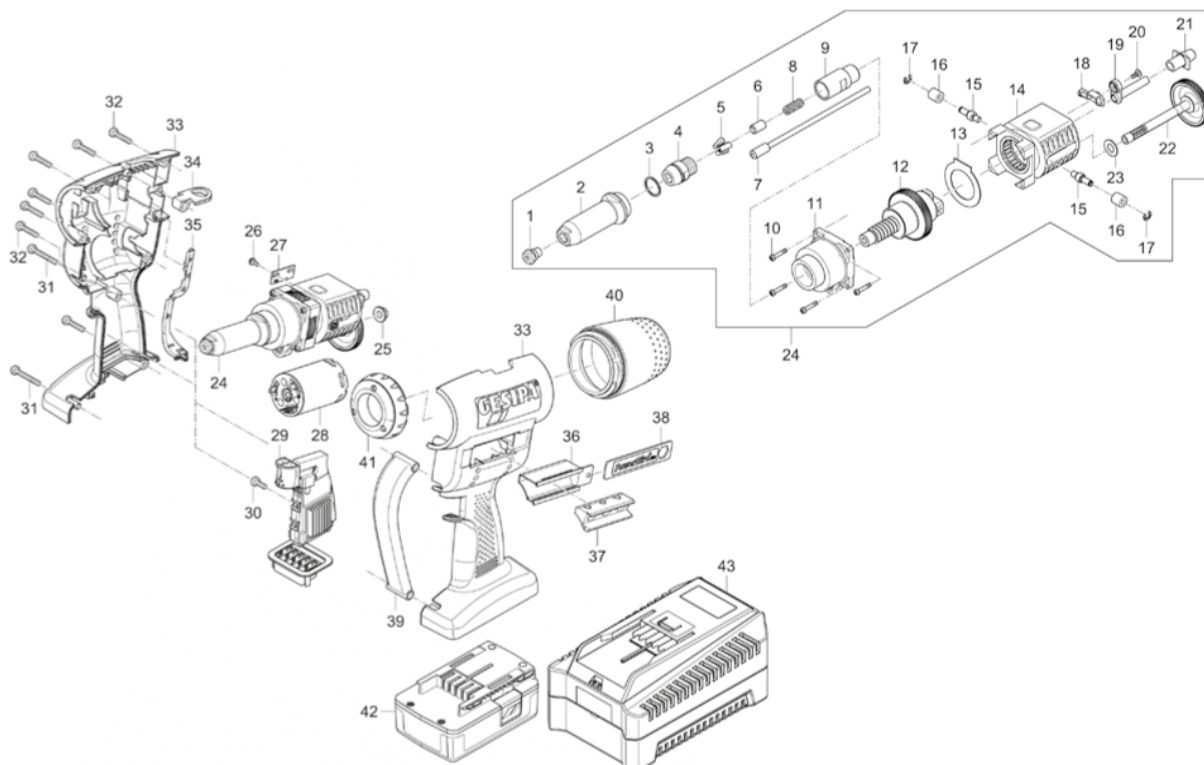

Battery powered blind rivet setting tools

Bird Pro series with spring-loaded trigger system

Spare part no.	Article no.	Designation
1 •	143 5591	Nosepiece 17/18 AV Support sleeve AV 1 complete
	143 4990	Nosepiece 17/20 AV Support sleeve AV 1 complete
	143 4991	Nosepiece 17/22 AV Support sleeve AV 1 complete
	143 5592	Nosepiece 17/24 AV Support sleeve AV 2 complete
	143 5593	Nosepiece 17/27 AV Support sleeve AV 2 complete
	143 5594	Nosepiece 17/29 AV Support sleeve AV 2 complete
	143 5595	Nosepiece 17/32 AV Support sleeve AV 2 complete
	143 5596	Nosepiece 17/36 AV Support sleeve AV 3 complete
	143 5597	Nosepiece 17/40 AV Support sleeve AV 3 complete
	143 5598	Nosepiece 17/45 AV Support sleeve AV 3 complete
2	143 5423	Union nut
3	143 5421	Steel head sleeve
4	143 4253	O-ring
5	145 0825	Support sleeve AccuBird®
	145 0826	Support sleeve PowerBird®
6 •	144 6012	O-ring
7 •	143 5392	Jaw housing
8 •	143 5568	Jaws (3-part)
	143 5384	Jaw Pusher PowerBird® Pro
	143 5448	Jaw Pusher AccuBird® Pro
9 •	143 5412	Spring
10	157 3351	Adapter AV
12 •	144 5994	Spring
13	144 5991	Grooved dowel pin
14	144 6053	O-ring
15	143 5418	Casing
16	144 5992	Switch
17	144 5768	Screw
18	143 5419	Bearing
19	143 5417	Adapter
20	143 4961	Sleeve
21	144 5767	Bearing
22	144 5766	Needle bearing
23	143 5406	Ball screw drive
24	143 4962	Washer
25	144 5764	Needle bearing
26	143 5397	Bearing cage
27	143 5385	Pin
28	143 4970	Sintered metal roller

Spare part no.	Article no.	Designation
29	144 5790	Lock washer
30	145 0817	Magnetic holder
31 •	143 5393	Channel tube
32	144 5990	Screw
33 •	143 4874	Tube
	143 5395	Pinion shaft PowerBird® Pro GE
34	143 5442	Pinion shaft PowerBird® Pro
	143 5449	Pinion shaft AccuBird® Pro
35	143 4967	Washer
	145 0829	Drive unit PowerBird® Pro GE AV max. Ø 4,5 mm
36	151 9075	Drive unit PowerBird® Pro AV max. Ø 4,5 mm
	151 9074	Drive unit AccuBird® Pro AV max. Ø 3,2 mm
37	144 5763	Sintered-metal bushing
38	143 5408	Plate
39	144 5989	Screw
	145 7645	Motor, complete PowerBird® Pro GE
40	146 3584	Motor, complete PowerBird® Pro
	145 0857	Motor, complete AccuBird® Pro
	146 3926	Control PowerBird® Pro GE AV
41	150 1672	Control PowerBird® Pro AV
	150 1673	Control AccuBird® Pro GE AV
42	144 5773	Screw, short
43	144 5987	Screw
44	144 5772	Screw, long
45	143 5401	Housing, complete
	144 5746	Hanger PowerBird® Pro GE
46	143 5416	Hanger PowerBird® Pro
	143 5017	Hanger AccuBird®
47	143 5403	Cable duct
48	143 5016	Nosepiece magazine
49	143 4978	Magazine insert
50	145 7646	Key PowerBird® Pro
	145 0858	Key AccuBird® Pro
51	143 5399	Tool bar
52	143 5396	Spent mandrel container, complete
53	145 7644	Light, complete
54 •	145 7641	Battery
	145 7642	Battery charger (EU)
55	145 7649	Battery charger (USA)
56	144 6010	Snap ring
57	143 5600	Nosepiece AccuBird® Pro
	143 5601	Nosepiece 3
58	143 5422	Support sleeve

• Wearing parts

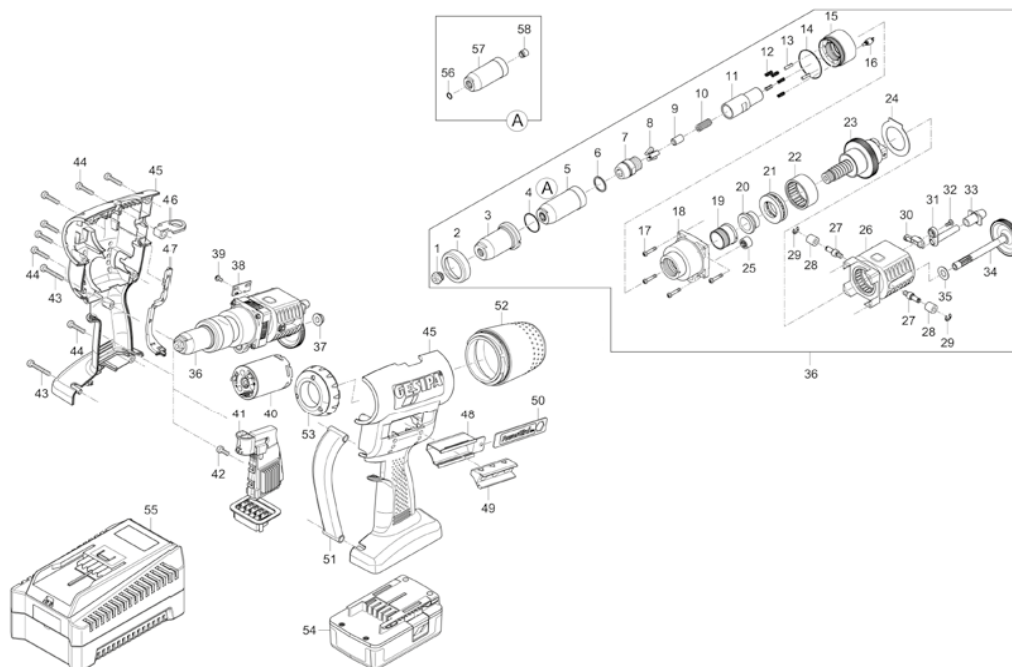

Battery powered blind rivet setting tools

Spring loaded trigger system for PowerBird®

Spare part no.	Article no.	Designation
1 •	143 4975	Nosepiece 17/32
	143 4977	Nosepiece 17/36
	143 4999	Nosepiece 17/40
	143 4860	Nosepiece 17/45
2	143 4889	Steel head sleeve
3 •	143 4129	Jaw housing
4 •	143 4104	Jaws (3-part)
5 •	143 4861	Jaw pusher
6	143 4864	Adapter
7 •	144 5753	Compression spring
8	143 4966	Wiper
9	143 4888	Union nut
10	143 4886	Adapter
11	144 5269	Spring

Spare part no.	Article no.	Designation
12	143 5529	O-ring
13	143 4885	Bushing
14	143 4890	Cover
15	144 5755	Stud bolt
16	144 5751	Spring
17	143 4887	Trigger
18	144 5328	Cylinder pin
19	144 5752	Push Button
20	143 4891	Housing, complete
	143 4892	E-control for spring loaded trigger system
	143 4815	Tube wrench required for assembly

• Wearing parts

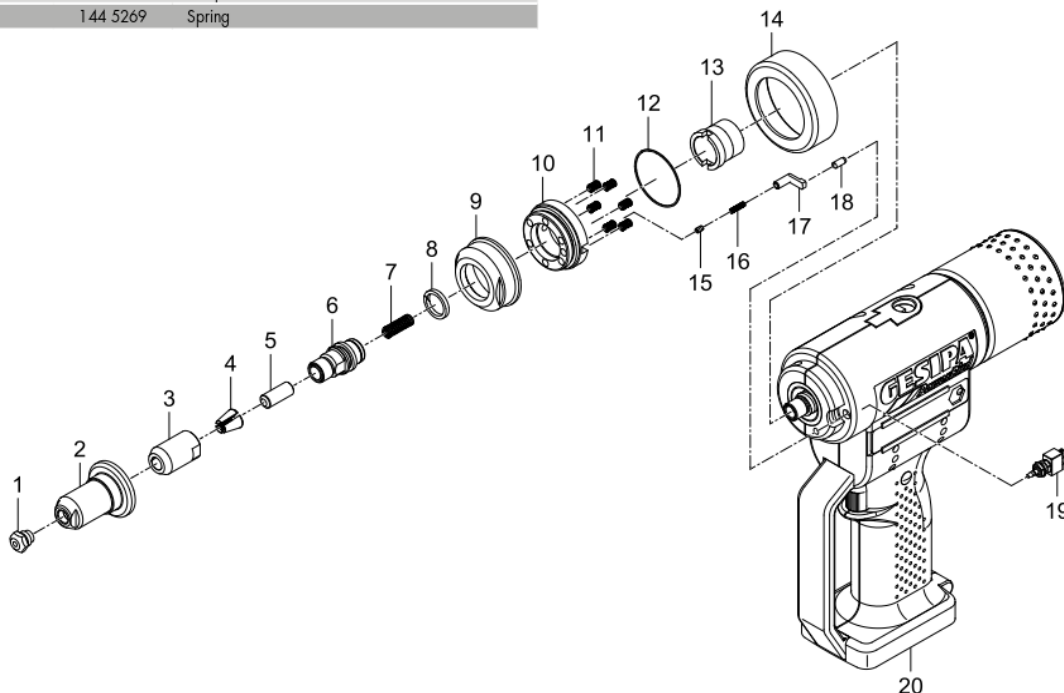

AccuBird® and PowerBird® angle head 90°

Spare part no.	Article no.	Designation
1 •	143 4977	Nosepiece 17/36
2	143 5926	Steel head sleeve
3 •	143 5918	Jaw housing
4 •	143 4104	Jaws (3-part)
5 •	143 4992	Jaw Pusher
6 •	144 5747	Spring
7	145 0624	Housing, complete
8	143 5911	Axis bolt
9	144 5545	Snap ring
10	143 5914	Spacer
11	143 5940	Lock activator
12	143 5935	Coupler
13	143 5936	Angle
14	143 5908	Bolt
15	143 5963	Protecting cap
16	144 6013	Screw
17	143 5938	Lock activator
18	145 0623	Fork head
19	143 5959	Adapter

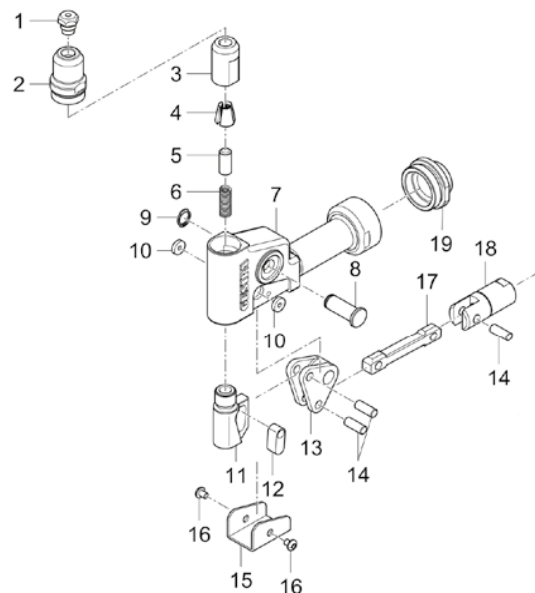

• Wearing parts

Accessories for battery powered blind rivet setting tools

One-piece extension units

Extension unit for AccuBird®

50 mm: Article no. 145 7273
 100 mm: Article no. 145 7274
 150 mm: Article no. 145 0622

	Spare part no.	Article no.	Designation
50 mm	1	143 4836	Steel head sleeve
	2	143 4837	Extension piece
	3	143 4903	Jaw pusher
100 mm	1	143 4839	Steel head sleeve
	2	143 4840	Extension piece
	3	143 4996	Jaw pusher
150 mm	1	143 4841	Steel head sleeve
	2	143 4842	Extension piece
	3	143 4905	Jaw pusher

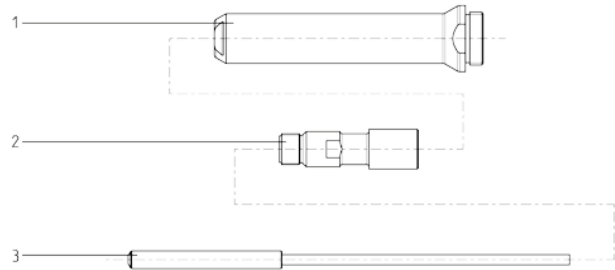

Extension unit for PowerBird®

50 mm: Article no. 145 7214
 100 mm: Article no. 145 7215
 150 mm: Article no. 146 4038

	Spare part no.	Article no.	Designation
50 mm	1	143 4836	Steel head sleeve
	2	143 4837	Extension piece
	3	143 4957	Adapter
	4	143 4966	Wiper
	5	143 4838	Jaw pusher
100 mm	1	143 4839	Steel head sleeve
	2	143 4840	Extension piece
	3	143 4957	Adapter
	4	143 4966	Wiper
	5	143 4870	Jaw pusher
150 mm	1	143 4841	Steel head sleeve
	2	143 4842	Extension piece
	3	143 4957	Adapter
	4	143 4966	Wiper
	5	143 4843	Jaw pusher

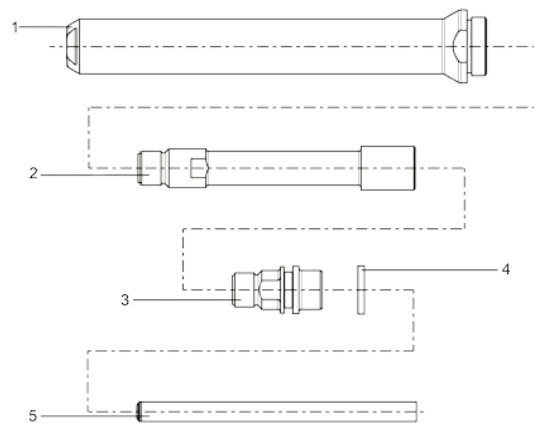

Extension unit for PowerBird® spring loaded trigger system

50 mm: Article no. 145 7222
 100 mm: Article no. 145 7224

	Spare part no.	Article no.	Designation
50 mm	1	143 4832	Steel head sleeve
	2	143 4833	Extension piece
	3	143 4834	Jaw pusher
100 mm	1	143 4849	Steel head sleeve
	2	143 4850	Extension piece
	3	143 4870	Jaw pusher

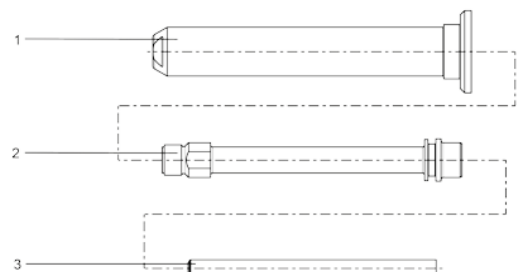

Accessories for battery powered blind rivet setting tools

One-piece extension units

Extension unit for AccuBird® Pro

- +35 mm:** Article no. 145 0860
- +85 mm:** Article no. 145 0861
- +135 mm:** Article no. 145 0862

	Spare part no.	Article no.	Designation
+35 mm	1	143 5473	Steel head sleeve
	2	145 0832	Adapter
	3	143 5427	Jaw pusher
+85 mm	1	143 5476	Steel head sleeve
	2	145 0833	Adapter
	3	143 5428	Jaw pusher
+135 mm	1	143 5487	Steel head sleeve
	2	145 0834	Adapter
	3	143 5429	Jaw pusher

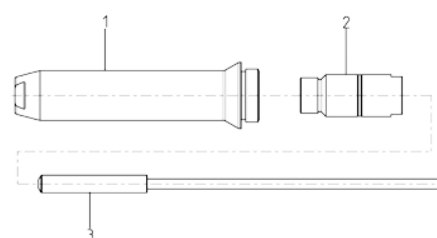

Extension unit for PowerBird® Pro Gold Edition

- +35 mm:** Article no. 145 7650
- +85 mm:** Article no. 145 7651
- +135 mm:** Article no. 145 0823

	Spare part no.	Article no.	Designation
+35 mm	1	143 5473	Steel head sleeve
	2	145 0832	Adapter
	3	143 5881	Intermediate bush
+85 mm	1	143 5476	Steel head sleeve
	2	145 0833	Adapter
	3	143 5882	Intermediate bush
+135 mm	1	143 5487	Steel head sleeve
	2	145 0834	Adapter
	3	143 5879	Intermediate bush

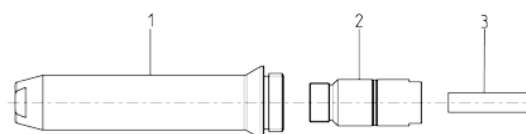

Extension unit for PowerBird® Pro Gold Edition spring loaded trigger system

- +50 mm:** Article no. 145 0821
- +100 mm:** Article no. 145 0822

	Spare part no.	Article no.	Designation
+50 mm	1	143 5433	Steel head sleeve AV
	2	143 4253	O-ring
	3	145 0830	Support sleeve AV, complete
	4	145 0835	Adapter
	5	143 5902	Intermediate bush 1
	6	143 5601	Nosepiece
	7	144 6010	Snap ring
	8	143 5431	Support sleeve AV
+100 mm	1	143 5434	Steel head sleeve AV
	2	143 4253	O-ring
	3	145 0831	Support sleeve AV, complete
	4	145 0836	Adapter
	5	143 5903	Intermediate bush 1
	6	143 5601	Nosepiece
	7	144 6010	Snap ring
	8	143 5432	Support sleeve AV

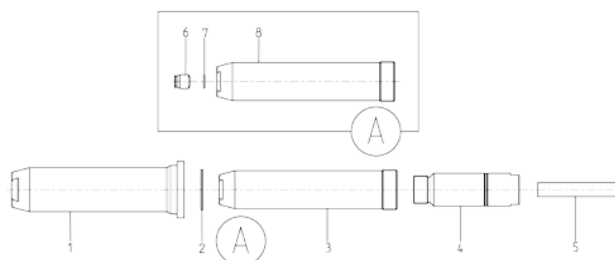

Accessories for battery powered blind rivet setting tools

Multi-piece extension units

arbitrary extension of the tool head in 100 mm steps

AccuBird® extension unit 100 mm

Article no. 145 7318

Spare part no.	Article no.	Designation
1	143 4995	Extension sleeve
2	143 4165	Extension piece
3	143 4996	Jaw pusher

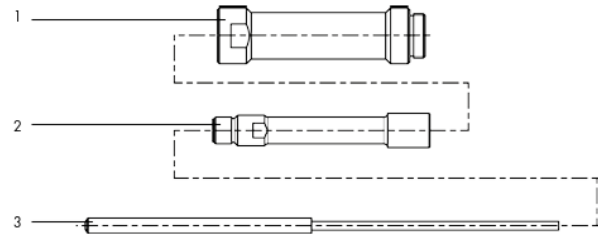

PowerBird® extension unit 100 mm

Article no. 145 7229

Spare part no.	Article no.	Designation
1	143 4995	Extension sleeve
2	143 4165	Extension piece
3	143 4870	Jaw pusher

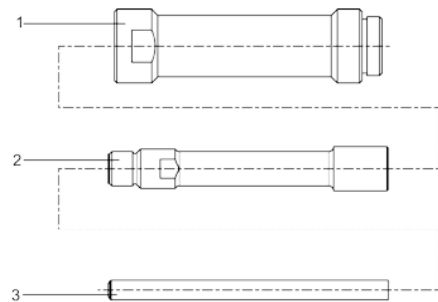

AccuBird® Pro extension unit 100 mm

Article no. 145 0859

Spare part no.	Article no.	Designation
1	143 4995	Extension sleeve
2	145 0836	Adapter
3	143 5430	Jaw pusher

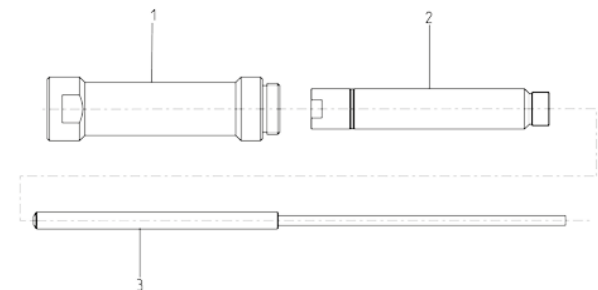

PowerBird® Pro Gold Edition extension unit 100 mm

Article no. 145 0820

Spare part no.	Article no.	Designation
1	143 4995	Extension sleeve
2	145 0836	Adapter
3	143 4870	Jaw pusher

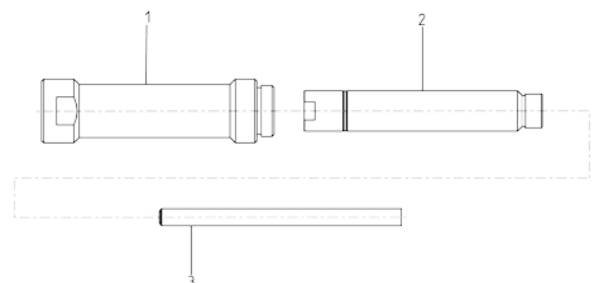

Hydro-pneumatic blind rivet setting tools

TAURUS® 1-4

Exploded drawing based on TAURUS® 2.
Specifications of other models in the boxes.

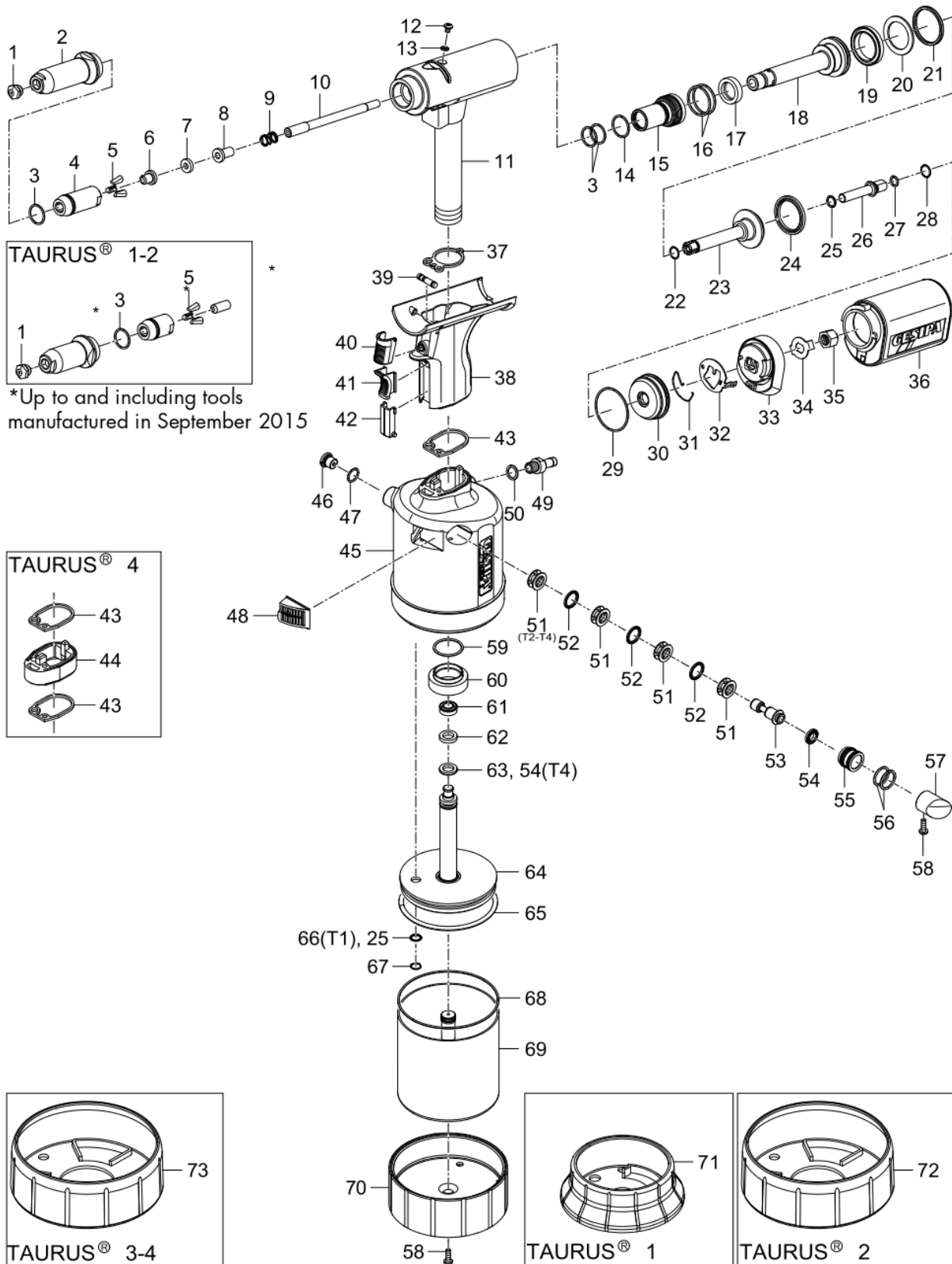

Hydro-pneumatic blind rivet setting tools

TAURUS® 1-4

Spare part no.	TAURUS®-Type	Article no.	Designation
1 •	T1	143 4976	Nosepiece17/18
		143 4994	Nosepiece17/20
		143 5018	Nosepiece17/22
		143 4955	Nosepiece17/24
	T2	143 4973	Nosepiece17/27
		143 4974	Nosepiece17/29
		143 4975	Nosepiece17/32
		143 4977	Nosepiece17/36
	T3, T4	143 4999	Nosepiece17/40
		143 4860	Nosepiece17/45
2		143 6003	Steel head sleeve 4
2a *	T1, T2	143 5587	Steel head sleeve
3 •		144 6012	O-ring
4 •		143 6002	Jaw housing 4
4a *	T1, T2	143 5574	Jaw housing
5 •		143 5568	Jaws (3-part)
6 •	T1	143 5507	Jaw pusher 1
	T2	143 5768	Jaw pusher 2
	T3, T4	143 6000	Jaw pusher 4
6a *	T1	143 5565	Jaw pusher 1
6b *	T2	143 5776	Jaw pusher 2
7		143 5999	Damping ring 4
8	T1	143 5509	Centre part 1
	T2	143 5769	Centre part 2
	T3, T4	143 6001	Centre part 3
9		146 3064	Spring
10	T1	143 5558	Nozzle tube 1
	T2	143 5764	Nozzle tube 2, longe
	T3, T4	143 5886	Nozzle tube 3, longe
11	T1	145 7745	Tool head 1, assembled
	T2, T3	145 7856	Tool head 2, assembled
	T4	145 7992	Tool head 4, assembled
12		144 6013	Oil screw plug
13		143 5612	Sealing ring M4
14		143 5629	O-ring
15		143 5681	Seal holder, complete
16		143 4227	O-ring
17		143 5630	Rod seal
18		143 5631	Draw bar
19		143 5632	Piston seal
20		143 5488	Supporting ring
21		143 5485	Piston seal
22		143 5671	O-ring
23		145 7746	Resetting piston, complete
24		143 5633	Piston seal
25		143 5635	Rod seal
26	T1	143 5852	Connecting piece 1
	T2, T3, T4	143 5765	Connecting piece 2/3
27		143 5519	O-ring
28		144 6167	Snap ring
29		143 5524	O-ring
30		143 5532	End cap
31		144 6028	Retaining spring
32		143 5664	Retainer
33		143 5663	Adapter
34		143 5842	Lock washer
35	T1	143 5849	Connecting piece nut 1
	T2, T3, T4	143 5766	Connecting piece nut 2/3
36	T1, T2	143 5677	Spent mandrel container, complete
	T3, T4	143 5964	Spent mandrel container, complete
37		143 5472	Flat gasket 1
38		145 7748	Grip, complete
39		145 7747	Distributing valve, complete
40		144 6025	Activation button
41		143 5642	Slider
42		143 5686	Orifice

Spare part no.	TAURUS®-Type	Article no.	Designation
43		143 5480	Flat gasket 2
44	T4	143 5998	Grip extension
45	T1	145 7749	Air cylinder 1, complete
	T2	145 7859	Air cylinder 2, complete
	T3	145 7950	Air cylinder 3, complete
	T4	145 7993	Air cylinder 4, complete
46		145 7750	Pressure relief valve, complete
47		143 5484	O-ring
48	T1	151 5051	Silencer 1, complete
	T2	145 7862	Silencer 2, complete
	T3, T4	145 7956	Silencer 3, complete
50		143 5667	Connecting nipple
51		144 6030	Sealing ring
52		143 5648	Spacer cage
53		143 5647	Rod seal
54		143 5651	Control piston
55		143 5675	Piston seal
56		143 5652	Piston housing
57		143 5688	O-ring
58	T1	144 6026	Stopper 1
	T2	144 6073	Stopper 2
	T3, T4	144 6100	Stopper 3
59		144 5773	Housing screw short
60		143 5486	O-ring
61		143 5492	Al nut
62	T1	143 5658	Piston seal
	T2, T3	143 5841	Piston seal
	T4	143 6007	Piston seal
63	T1	143 5657	Guide ring 1
	T2, T3	143 5825	Guide ring 2
	T4	143 6006	Guide ring 4
64	T1	143 5656	Piston seal
	T2, T3	143 5670	Piston seal
65	T1	145 7751	Air piston 1, complete
	T2	145 7860	Air piston 2, complete
	T3	145 7952	Air piston 3, complete
	T4	145 7994	Air piston 4, complete
66	T1	143 5660	O-ring
	T2	143 5834	O-ring
	T3, T4	143 5937	O-ring
67	T1	143 5659	Rod seal
68	T1	144 6027	Snap ring
	T2, T3, T4	144 6082	V-profile ring
69	T1	143 5680	O-ring
	T2	143 5839	O-ring
	T3, T4	143 5927	O-ring
70	T1	145 7752	Cylinder 1, complete
	T2	145 7861	Cylinder 2, complete
	T3	145 7953	Cylinder 3, complete
	T4	145 7995	Cylinder 4, complete
71	T1	143 5508	Bottom 1
	T2	143 5761	Bottom 2
	T3, T4	143 5874	Bottom 3
72	T1	143 6394	Rubber foot 1
73	T2	143 6371	Rubber foot 2
74	T3, T4	143 5900	Rubber foot 3 - 4
	T2, T3	145 7863	Jaw pusher changeover set
	T1	145 7700	Changeover set
	T2, T3, T4	145 7703	Changeover set
		144 5294	Hydraulic oil refill bottle, 100 ml

• Wearing parts

* Up to and including tools manufactured in September 2015.
You will find detailed nosepiece allocation tables on page 354.

You will find spare part kits for TAURUS® 1-4 on page 386.

Hydro-pneumatic blind rivet setting tools

TAURUS® 5-6

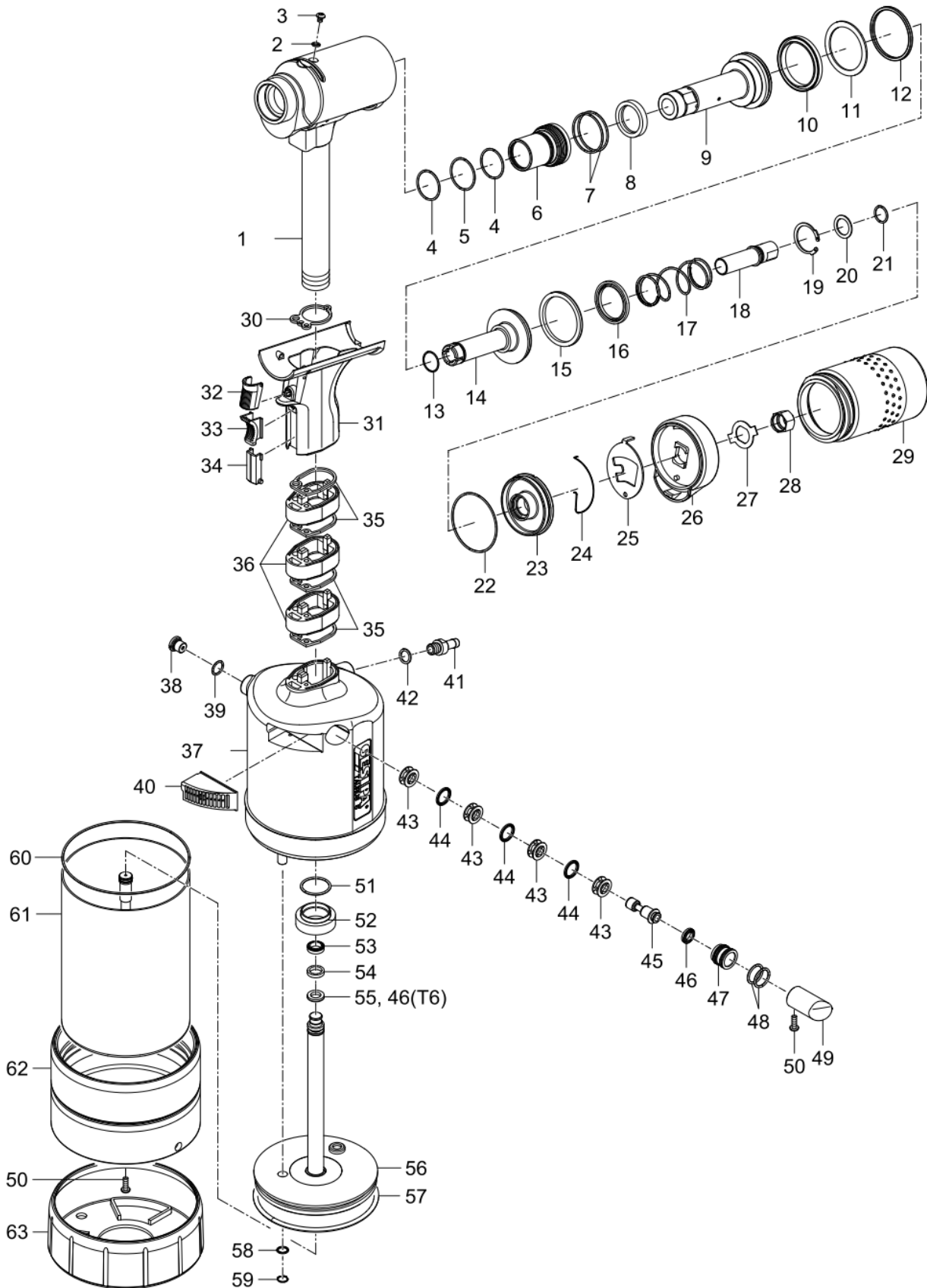

Hydro-pneumatic blind rivet setting tools

TAURUS® 5-6

Spare part no.	TAURUS®-Type	Article no.	Designation
1	T5	145 8010	Tool head 5, assembled
	T6	145 8023	Tool head 6, assembled
2		143 5612	Sealing ring M4
3		144 6013	Oil screw plug
4		143 6044	O-ring
5 •		143 6045	O-ring
6		145 8011	Seal holder, complete
7 •		143 6047	O-ring
8 •		143 6048	Rod seal
9		143 6036	Draw bar
10 •		143 6049	Cylinder seal
11 •		143 6052	Supporting ring
12 •		143 6051	Piston seal
13		143 6046	O-ring
14		145 8012	Resetting piston, complete
15		143 6050	Lip ring
16 •		143 6053	Rod seal
17		144 6123	Spring
18		143 6030	Connecting piece
19		144 6124	V-profile ring
20		144 6125	Washer
21		143 6042	O-ring
22		143 6043	O-ring
23		143 6034	End cap
24		144 6122	Retaining spring
25		143 6026	Retainer
26		143 6028	Adapter
27 •		143 6025	Lock washer
28		143 6029	Connecting piece nut
29		143 6058	Spent mandrel container, complete
30 •		143 5472	Flat gasket 1
31		145 7748	Grip, complete
32		144 6025	Activation button
33		143 5642	Slider
34		143 5686	Orifice
35 •		143 5480	Flat gasket 2
36		143 5998	Grip extension

Spare part no.	TAURUS®-Type	Article no.	Designation
37	T5	145 8013	Air cylinder 5, complete
	T6	146 4043	Air cylinder 6, complete
38		145 7750	Pressure relief valve, complete
39		143 5484	O-ring
40		145 7956	Silencer 3, complete
41		144 6030	Seal
42		143 5667	Connecting nipple
43		143 5648	Spacer cage
44		143 5647	Rod seal
45		143 5651	Control piston
46 •		143 5675	Piston seal
47		143 5652	Piston housing
48		143 5688	O-ring
49		144 5773	Housing screw, short
50		144 6100	Stopper 3
51		143 5486	O-ring
52		143 5492	Al nut
53 •	T5	143 6056	Cylinder seal
	T6	143 6007	Piston seal
54 •	T5	143 6040	Guide ring 5
	T6	143 6006	Guide ring 4
55 •	T5	143 6055	Lip ring
56	T5	145 8015	Air piston 5, complete
	T6	145 8024	Air piston 6, complete
57 •		143 5937	O-ring
58		143 5635	Rod seal
59		144 6082	V-profile ring
60		143 5927	O-ring
61	T5	145 8014	Cylinder 5, complete
	T6	146 4044	Cylinder 6, complete
62		143 6027	Al bottom
63		143 5900	Rubber foot
		144 5294	Hydraulic oil refill bottle, 100 ml

• Wearing parts

Hydro-pneumatic blind rivet setting tools

Spring loaded trigger system for TAURUS® 1-4 up to June 2013

Spare part no.	TAURUS®-Type	Article no.	Designation
1 a	T1	145 7696	Tool head 1, assembled
1 b	T2, T3	145 7842	Tool head 2, assembled
1 c	T4	145 7996	Tool head 4, assembled
2		145 7697	Seal holder AV
3		143 5498	Casing
4		143 6010	Guiding sleeve
5		143 5499	Union nut
6 •		143 5529	O-ring
7		143 5490	Steel head sleeve AV
9		145 7728	Stamp
13		145 7695	Grip AV, complete
15		144 5994	Spring
21		143 5497	Control piston AV
23		143 5999	Damping ring 4
24 a •	T1	143 5507	Jaw pusher 1
24 b •	T2	143 5768	Jaw pusher 2
24 c •	T3, T4	143 6000	Jaw pusher 4
25 a	T1	143 5509	Centre part 1
25 b	T2	143 5769	Centre part 2
25 c	T3, T4	143 6001	Centre part 4
26 •		143 6002	Jaw housing 4

• Wearing parts

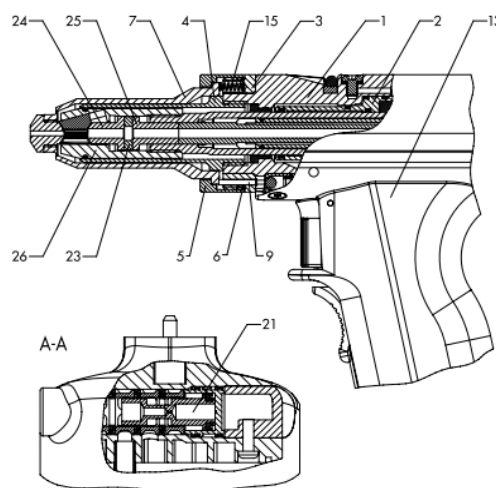

Spring loaded trigger system for TAURUS® 1-4 as from March 2013

Spare part no.	TAURUS®-Type	Article no.	Designation
1 •	T1	143 5591	Nosepiece 17/18 AV
		143 4990	Nosepiece 17/20 AV
		143 4991	Nosepiece 17/22 AV
		143 5592	Nosepiece 17/24 AV
	T2	143 5593	Nosepiece 17/27 AV
		143 5594	Nosepiece 17/29 AV
		143 5595	Nosepiece 17/32 AV
		143 5596	Nosepiece 17/36 AV
T3, T4	143 5597	Nosepiece 17/40 AV	
	143 5598	Nosepiece 17/45 AV	
2		143 5466	Steel head sleeve
3	T1	145 0887	Support sleeve AV, complete
	T2	145 0943	Support sleeve AV, complete
4	T3, T4	145 0978	Support sleeve AV, complete
		144 6012	O-Ring
5		143 6002	Jaw housing 4
6 •		143 5568	Jaws (3-part)
7	T1	143 5507	Jaw pusher 1
	T2	143 5768	Jaw pusher 2
	T3, T4	143 6000	Jaw pusher 4
8		143 5999	Damping ring 4

Spare part no.	TAURUS®-Type	Article no.	Designation
9	T1	143 5509	Centre part 1
	T2	143 5769	Centre part 2
	T3, T4	143 6001	Centre part 4
10*		146 3064	Spring*
11		143 5499	Union nut
12		144 5994	Spring
13		144 5995	Allen screw
14		152 4521	Stamp
15		143 5529	O-Ring
16		143 5498	Casing
17	T1	145 7696	Tool head 1, assembled
	T2, T3	145 7842	Tool head 2, assembled
	T4	145 7996	Tool head 4, assembled
18		145 7695	Grip AV, complete
19		144 6010	Snap ring
20	T1	143 5599	Nosepiece Ø 2,5
	T2	143 5600	Nosepiece Ø 3,2
	T3, T4	143 5601	Nosepiece Ø 4,5
21		143 5467	Support sleeve AV

• Wearing parts

* The spring has been installed since 08.09.2015.

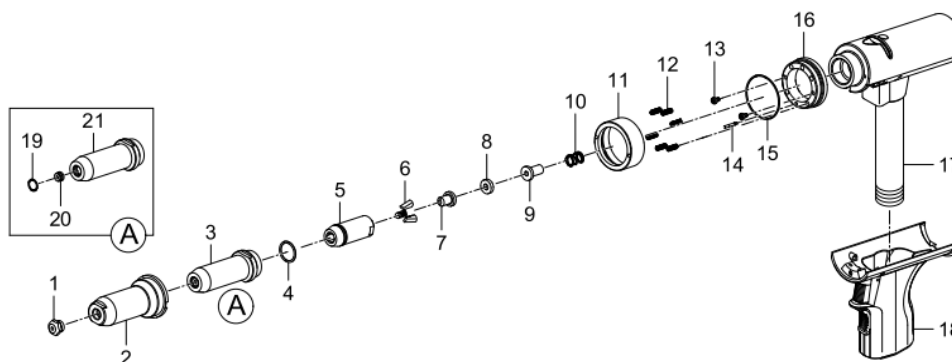

Accessories for TAURUS® blind rivet setting tools

Repair tools for TAURUS®

Article no. 145 7735

Spare part no.	Article no.	Designation
1	143 5672*	Allen key
2	144 6031*	Slot wrench
3	143 5674*	Clamp element for Taurus tool head
4	143 5673	Assembly device

*These tools are also suitable for FireFox® 1 F - 2

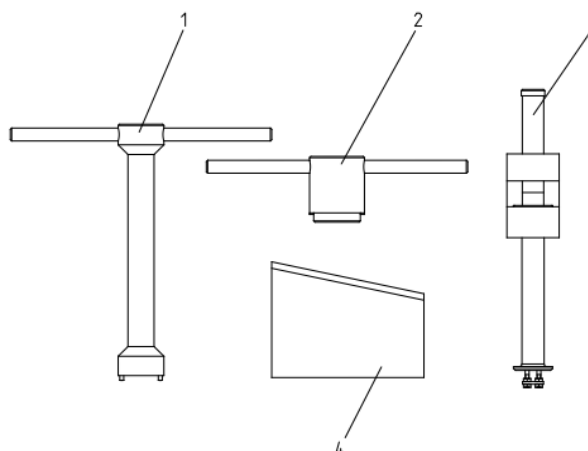

Changeover set spent mandrel container

as for PH 2000

for TAURUS® 1:

Article no. 145 7700

for TAURUS® 2,3,4:

Article no. 145 7703

Spare part no.	Article no.	Designation
1	145 7701	End cap T 1, complete
1	145 7702	End cap T 2, 3 and 4, complete
2	143 4233	Spent mandrel container
3	143 5521	Cover
4	144 5295	Air deflector

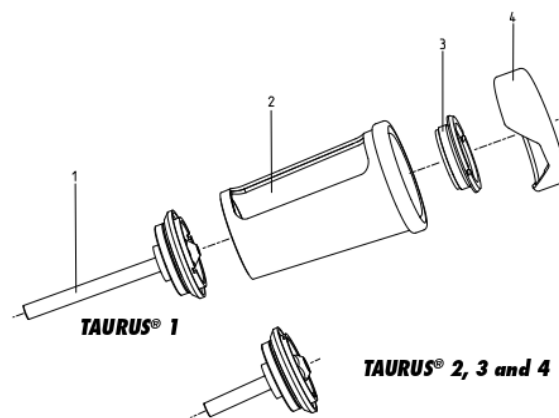

Rivet counter sensor changeover set for TAURUS® 1-4

for TAURUS® 1 Article no. 145 7698

for TAURUS® 2-4 Article no. 151 6858

Spare part no.	TAURUS®-Type	Article no.	Designation
1	T2, T3, T4	151 6859	End cap
2		143 5514	Housing
3		144 6002	Screw connection
4		144 6004	Hose
5		144 5518	Cable tie
6		143 5515	Locking washer
7		143 5522	Nut
8		143 5523	Ring sensor
9		144 6001	Allen screw
10		143 5525	Tube
11		143 5526	Connecting piece
12		143 5532	End cap

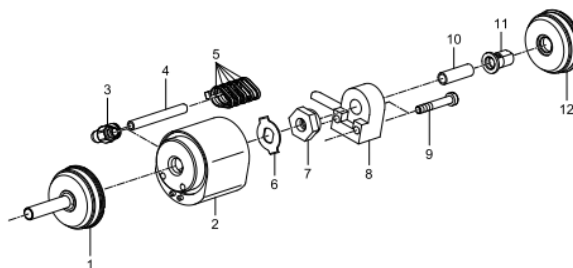

Accessories for TAURUS® blind rivet setting tools

TAURUS® 1-4 with parallel head

Article no. 145 0885

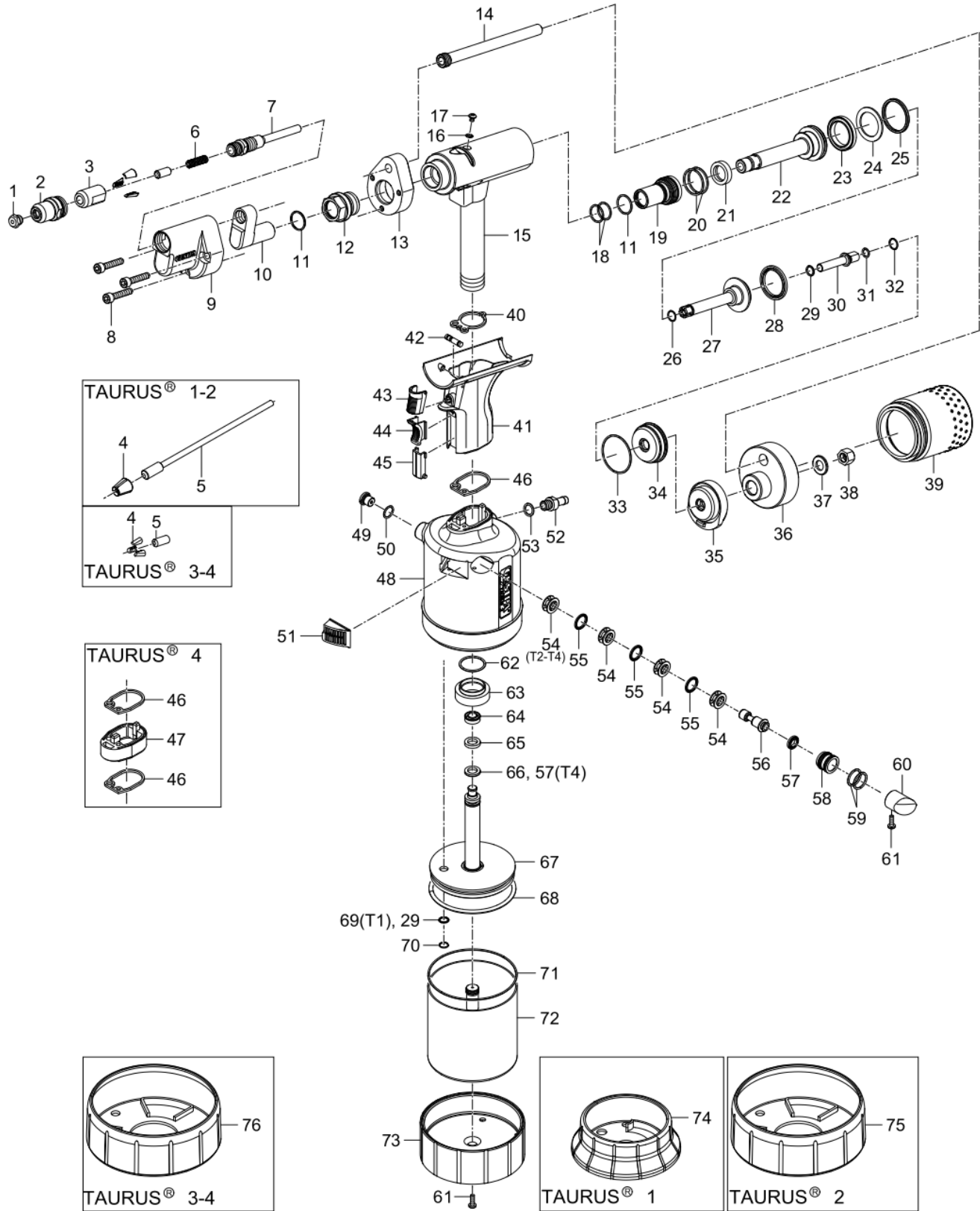

Accessories for TAURUS® blind rivet setting tools

TAURUS® 1-4 with parallel head

Spare part no.	TAURUS®-Type	Article no.	Designation
1	T1	143 4976	Nosepiece 17/18
		143 4994	Nosepiece 17/20
		143 5018	Nosepiece 17/22
		143 4955	Nosepiece 17/24
	T2	143 4973	Nosepiece 17/27
		143 4974	Nosepiece 17/29
		143 4975	Nosepiece 17/32
		143 4977	Nosepiece 17/36
	T3, T4	143 4999	Nosepiece 17/40
		143 4860	Nosepiece 17/45
2		143 5926	Steel head sleeve
3 •		143 5918	Jaw housing
4 •	T1, T2	143 4958	Jaws (3-part) up to rivet-Ø 4 mm (Nosepiece 17/24)
	T3, T4	143 4104	Jaws (3-part)
5 •	T1, T2	143 4959	Jaw Pusher
	T3, T4	143 4992	Jaw Pusher
6 •		144 5747	Spring
7		143 5616	Nozzle tube
8		144 5976	Allen screw
9		143 5617	Housing
10		143 5619	Lock activator
11		143 5629	O-ring
12		144 6019	Intermediate screw
13		143 5618	Baseplate
14		143 5613	Suction nozzle
15	T1	145 7745	Tool head 1, assembled
	T2, T3	145 7856	Tool head 2, assembled
	T4	145 7992	Tool head 4, assembled
16		144 6013	Oil screw plug
17		143 5612	Sealing ring M4
18		144 6012	O-ring
19		143 5681	Seal holder, complete
20		143 4227	O-ring
21		143 5630	Rod seal
22		143 5631	Draw bar
23		143 5632	Piston seal
24		143 5488	Supporting ring
25		143 5485	Piston seal
26		143 5671	O-ring
27		145 7746	Resetting piston, complete
28		143 5633	Piston seal
29		143 5635	Rod seal
30	T1	143 5852	Connecting piece 1
	T2, T3, T4	143 5765	Connecting piece 2/3
31		143 5519	O-ring
32		144 6167	Snap ring
33		143 5524	O-ring
34		143 5532	End cap
35		143 5614	Connection adapter
36		143 5615	Adapter
37		144 6020	Washer
38		143 5766	Connecting piece nut
39		143 6058	Spent mandrel container
40		143 5472	Flat gasket 1
41		145 7748	Grip, complete
42		145 7747	Distributing valve complete
43		144 6025	Activation button
44		143 5642	Slider
45		143 5686	Orifice
46		143 5480	Flat gasket 2
47	T4	143 5998	Grip extension

Spare part no.	TAURUS®-Type	Article no.	Designation
48	T1	145 7749	Air cylinder 1, complete
	T2	145 7859	Air cylinder 2, complete
	T3	145 7950	Air cylinder 3, complete
	T4	145 7993	Air cylinder 4, complete
49		145 7750	Pressure relief valve, complete
50		143 5484	O-ring
51	T1	151 5051	Silencer 1 complete
	T2	145 7862	Silencer 2 complete
	T3, T4	145 7956	Silencer 3 complete
52		143 5667	Connecting nipple
53		144 6030	Sealing ring
54		143 5648	Spacer cage
55		143 5647	Rod seal
56		143 6187	Control piston
57		143 5675	Piston seal
58		143 5652	Piston housing
59		143 5688	O-ring
60	T1	144 6026	Stopper 1
	T2	144 6073	Stopper 2
	T3, T4	144 6100	Stopper 3
61		144 5773	Housing screw short
62		143 5486	O-ring
63		143 5492	Alu nut
64	T1	143 5658	Piston seal
	T2, T3	143 5841	Piston seal
	T4	143 6007	Piston seal
65	T1	143 5657	Guide ring 1
	T2, T3	143 5825	Guide ring 2
	T4	143 6006	Guide ring 4
66	T1	143 5656	Piston seal
	T2, T3	143 5670	Piston seal
67	T1	145 7751	Air piston 1 complete
	T2	145 7860	Air piston 2 complete
	T3	145 7952	Air piston 3 complete
	T4	145 7994	Air piston 4 complete
68	T1	143 5660	O-ring
	T2	143 5834	O-ring
69	T3, T4	143 5937	O-ring
	T1	143 5659	Rod seal
70	T1	144 6027	Snap ring
	T2, T3, T4	144 6082	V-ring
71	T1	143 5680	O-ring
	T2	143 5839	O-ring
	T3, T4	143 5927	O-ring
72	T1	145 7752	Cylinder 1 complete
	T2	145 7861	Cylinder 2 complete
	T3	145 7953	Cylinder 3 complete
	T4	145 7995	Cylinder 4 complete
73	T1	143 5508	Bottom 1
	T2	143 5761	Bottom 2
	T3, T4	143 5874	Bottom 3
74	T1	143 6394	Rubber foot 1
75	T2	143 6371	Rubber foot 2
76	T3, T4	143 5900	Rubber foot 3-4
		144 5294	Hydraulic oil refill bottle 100ml

• Wearing parts
You will find detailed nosepiece allocation tables on page 3.54.

Accessories for TAURUS® blind rivet setting tools

One-piece extension units

Extension unit for TAURUS® 1- 4 (up to and including September 2015)

for TAURUS® 1	50 mm:	Article no.	145 7736
for TAURUS® 1	100 mm:	Article no.	145 7738
for TAURUS® 1	150 mm:	Article no.	146 4042
for TAURUS® 2	50 mm:	Article no.	145 7837
for TAURUS® 2	100 mm:	Article no.	145 7838
for TAURUS® 2	150 mm:	Article no.	145 7847
for TAURUS® 2	200 mm:	Article no.	145 7845
for TAURUS® 3 and 4	+35 mm:	Article no.	145 7932
for TAURUS® 3 and 4	+85 mm:	Article no.	145 7933
for TAURUS® 3 and 4	+135 mm:	Article no.	145 7937

Type	Extension	Spare part no.	Article no.	Designation	
TAURUS® 1	50 mm	1	143 5473	Steel head sleeve	
		2	145 7737	Adapter	
		3	143 5474	Jaw pusher	
	100 mm	1	143 5476	Steel head sleeve	
		2	145 7739	Adapter	
		3	143 5477	Jaw pusher	
	TAURUS® 2	50 mm	1	143 5487	Steel head sleeve
			2	144 6012	O-ring
			3	143 6002	Jaw housing
100 mm		4	143 5507	Jaw Pusher	
		5	143 5999	Damping ring	
		6	143 5509	Centre part	
150 mm		7	146 3064	Spring	
		8	143 5544	Intermediate bush	
		9	143 5890	Adapter	
TAURUS® 3 and 4	50 mm	1	143 5473	Steel head sleeve	
		2	145 7737	Adapter	
		3	143 5762	Jaw pusher	
	100 mm	1	143 5476	Steel head sleeve	
		2	145 7739	Adapter	
		3	143 5763	Jaw pusher	
	150 mm	1	143 5487	Steel head sleeve	
		2	144 6012	O-ring	
		3	143 6002	Jaw housing	
200 mm	4	143 5768	Jaw Pusher		
	5	143 5999	Damping ring		
	6	143 5769	Centre part		
+35 mm	7	146 3064	Spring		
	8	143 5792	Intermediate bush		
	9	143 5890	Adapter		
+85 mm	1	143 5801	Steel head sleeve		
	2	145 0939	Adapter		
	3	143 5803	Jaw pusher		
+135 mm	1	143 5473	Steel head sleeve		
	2	145 7938	Adapter		
	3	143 5881	Jaw pusher		
TAURUS® 3 and 4	+85 mm	1	143 5476	Steel head sleeve	
		2	145 7939	Adapter	
		3	143 5882	Jaw pusher	
+135 mm	+135 mm	1	143 5487	Steel head sleeve	
		2	143 5890	Adapter	
		3	143 5879	Jaw pusher	

146 4042 / 145 7847

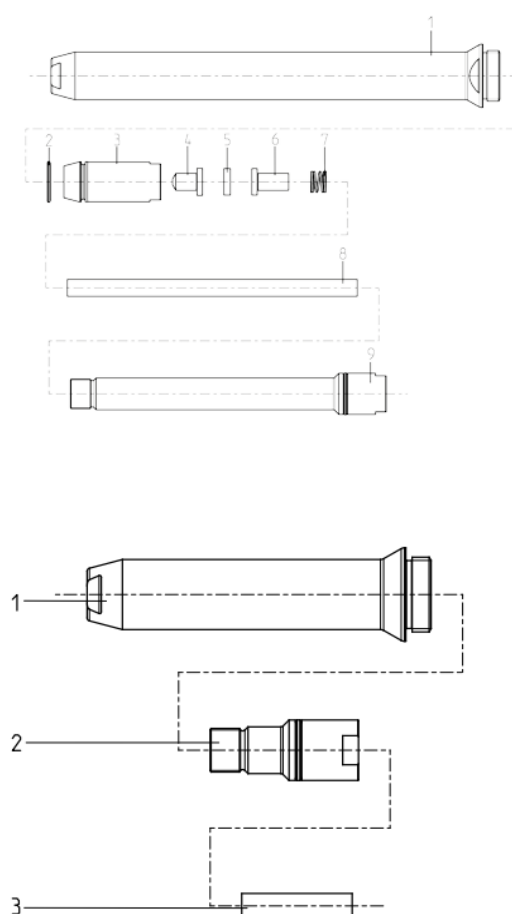

Accessories for TAURUS® blind rivet setting tools

One-piece extension units

Extension unit for TAURUS® 1- 4 (as from October 2015)

for TAURUS® 1	+35 mm:	Article no.	146 4345
for TAURUS® 1	+85 mm:	Article no.	146 4346
for TAURUS® 1	+135 mm:	Article no.	146 4347
for TAURUS® 2	+35 mm:	Article no.	145 8042
for TAURUS® 2	+85 mm:	Article no.	146 4350
for TAURUS® 2	+135 mm:	Article no.	146 4351
for TAURUS® 2	+185 mm:	Article no.	146 4352
for TAURUS® 3 and 4	+35 mm:	Article no.	145 7932
for TAURUS® 3 and 4	+85 mm:	Article no.	145 7933
for TAURUS® 3 and 4	+135 mm:	Article no.	145 7937

Type	Extension	Spare part no.	Article no.	Designation
TAURUS® 1	+35 mm	1	143 5473	Steel head sleeve
		2	145 7938	Adapter
		3	146 4338	Intermediate bush
	+85 mm	1	143 5476	Steel head sleeve
		2	145 7939	Adapter
		3	146 4339	Intermediate bush
	+135 mm	1	143 5487	Steel head sleeve
		2	143 5890	Adapter
		3	143 5544	Intermediate bush
TAURUS® 2	+35 mm	1	143 5473	Steel head sleeve
		2	145 7938	Adapter
		3	143 6100	Intermediate bush
	+85 mm	1	143 5476	Steel head sleeve
		2	145 7939	Adapter
		3	143 5819	Intermediate bush
	+135 mm	1	143 5487	Steel head sleeve
		2	143 5890	Adapter
		3	143 5792	Intermediate bush
+185 mm	1	143 5801	Steel head sleeve	
	2	146 4343	Adapter	
	3	146 4340	Intermediate bush	
TAURUS® 3 and 4	+35 mm	1	143 5473	Steel head sleeve
		2	145 7938	Adapter
		3	143 5881	Jaw pusher
	+85 mm	1	143 5476	Steel head sleeve
		2	145 7939	Adapter
		3	143 5882	Jaw pusher
	+135 mm	1	143 5487	Steel head sleeve
		2	143 5890	Adapter
		3	143 5879	Jaw pusher

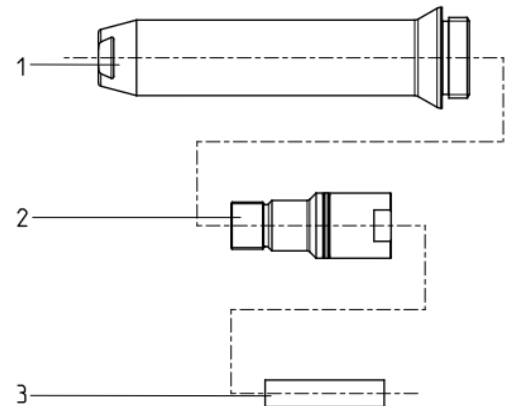

Accessories for TAURUS® blind rivet setting tools

One-piece extension units

Extension unit for TAURUS® 1- 4 with spring-loaded trigger system (as from March 2013)

for TAURUS® 1	50 mm:	Article no.	145 0880
for TAURUS® 1	100 mm:	Article no.	145 7727
for TAURUS® 2	50 mm:	Article no.	145 7857
for TAURUS® 2	100 mm:	Article no.	145 7858
for TAURUS® 3 and 4	50 mm:	Article no.	145 7959
for TAURUS® 3 and 4	100 mm:	Article no.	145 7960

Type	Extension	Spare part no.	Article no.	Designation
TAURUS® 1	50 mm	1	143 5591	Nosepiece 17/18 AV
			143 4990	Nosepiece 17/20 AV
			143 4991	Nosepiece 17/22 AV
		2	143 5870	Steel head sleeve AV
			145 0888	Support sleeve AV, complete
			145 7737	Adapter, complete
			143 5553	Intermediate bush 1
			144 6010	Snap ring
	100 mm	1	143 5591	Nosepiece 17/18 AV
			143 4990	Nosepiece 17/20 AV
			143 4991	Nosepiece 17/22 AV
		2	143 5872	Steel head sleeve AV
			145 0889	Support sleeve AV, complete
			145 7739	Adapter, complete
			143 5556	Intermediate bush 1
			144 6010	Snap ring
TAURUS® 2	50 mm	1	143 5592	Nosepiece 17/24 AV
			143 5593	Nosepiece 17/27 AV
			143 5594	Nosepiece 17/29 AV
			143 5595	Nosepiece 17/32 AV
		2	143 5870	Steel head sleeve AV
			145 0944	Support sleeve AV, complete
			145 7737	Adapter, complete
			143 5798	Intermediate bush 2
	100 mm	1	143 5592	Nosepiece 17/24 AV
			143 5593	Nosepiece 17/27 AV
			143 5594	Nosepiece 17/29 AV
			143 5595	Nosepiece 17/32 AV
		2	143 5872	Steel head sleeve AV
			145 0945	Support sleeve AV, complete
			145 7739	Adapter, complete
			143 5797	Intermediate bush 2
TAURUS® 3 and 4	50 mm	1	143 5596	Nosepiece 17/36 AV
			143 5597	Nosepiece 17/40 AV
			143 5598	Nosepiece 17/45 AV
		2	143 5870	Steel head sleeve AV
	145 0979		Support sleeve AV, complete	
	145 7737		Adapter, complete	
	143 5902		Intermediate bush 3/4	
	100 mm	1	143 5596	Nosepiece 17/36 AV
143 5597			Nosepiece 17/40 AV	
143 5598			Nosepiece 17/45 AV	
143 5872			Steel head sleeve AV	
2		145 0980	Support sleeve AV, complete	
		145 7739	Adapter, complete	
		143 5903	Intermediate bush 3/4	
		144 6010	Snap ring	

Type	Extension	Spare part no.	Article no.	Designation
TAURUS® 3 and 4	50 mm	1	143 5596	Nosepiece 17/36 AV
			143 5597	Nosepiece 17/40 AV
			143 5598	Nosepiece 17/45 AV
		2	143 5870	Steel head sleeve AV
			145 0979	Support sleeve AV, complete
			145 7737	Adapter, complete
			143 5902	Intermediate bush 3/4
			144 6010	Snap ring
	100 mm	1	143 5596	Nosepiece 17/36 AV
			143 5597	Nosepiece 17/40 AV
			143 5598	Nosepiece 17/45 AV
			143 5872	Steel head sleeve AV
		2	145 0980	Support sleeve AV, complete
			145 7739	Adapter, complete
			143 5903	Intermediate bush 3/4
			144 6010	Snap ring

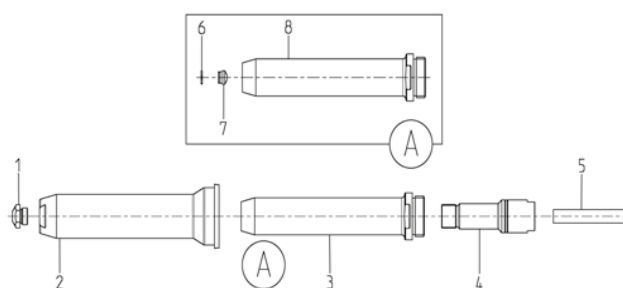

Accessories for TAURUS® blind rivet setting tools

One-piece extension units

Extension unit for TAURUS® 1- 4 spring-loaded trigger system (up to June 2013)

for TAURUS® 1	50 mm:	Article no. 152 5991
for TAURUS® 1	100 mm:	Article no. 145 7709
for TAURUS® 2	50 mm:	Article no. 145 7836
for TAURUS® 2	100 mm:	Article no. 145 7835
for TAURUS® 3 and 4	50 mm:	Article no. 145 7928
for TAURUS® 3 and 4	100 mm:	Article no. 145 7929

Type	Extension	Spare part no.	Article no.	Designation
TAURUS® 1	50 mm	1	143 5551	Steel head sleeve
		2	143 5554	Support sleeve
		3	145 7737	Adapter
		4	143 5553	Intermediate bush
	100 mm	1	143 5555	Steel head sleeve
		2	143 5557	Support sleeve
		3	145 7739	Adapter
		4	143 5556	Intermediate bush
TAURUS® 2	50 mm	1	143 5551	Steel head sleeve
		2	143 5554	Support sleeve
		3	145 7737	Adapter
		4	143 5798	Intermediate bush
	100 mm	1	143 5555	Steel head sleeve
		2	143 5557	Support sleeve
		3	145 7739	Adapter
		4	143 5797	Intermediate bush
TAURUS® 3 - 4	50 mm	1	143 5551	Steel head sleeve
		2	143 5554	Support sleeve
		3	145 7938	Adapter
		4	143 5902	Intermediate bush
	100 mm	1	143 5555	Steel head sleeve
		2	143 5557	Support sleeve
		3	145 7939	Adapter
		4	143 5903	Intermediate bush

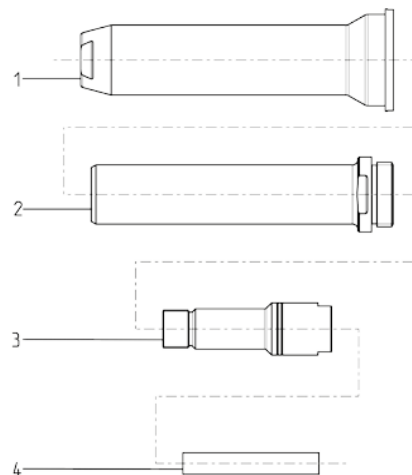

Multi-piece extension units

Extension modules for TAURUS® 1-4

arbitrary extension of the tool head in 100 mm steps

for TAURUS® 1:	Article no. 145 7743
for TAURUS® 2:	Article no. 145 7848
for TAURUS® 3 and 4:	Article no. 145 7947

Type	Spare part no.	Article no.	Designation
TAURUS® 1	1	143 4995	Extension sleeve
	2	143 4165	Extension piece
	3	143 5556	Intermediate bush
TAURUS® 2	1	143 4995	Extension sleeve
	2	143 4165	Extension piece
	3	143 5797	Intermediate bush
TAURUS® 3 - 4	1	143 4995	Extension sleeve
	2	143 4165	Extensionstück
	3	143 5903	Intermediate bush

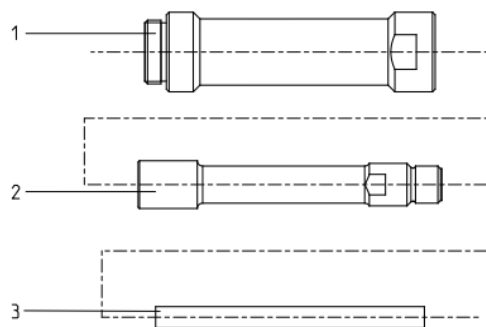

Accessories for TAURUS® blind rivet setting tools

Heads for TAURUS® 5-6

for 7.8mm (5/16") TIBULB structure rivet

Article no. 145 8008

Spare part no.	Article no.	Designation
1	145 8016	Nozzle tube, complete
2	143 6064	Damping ring
3	143 6068	Jaw pusher
4 •	143 5568	Jaw**
5	143 6070	Jaw housing
6	143 6069	Centre part
7 •	143 6067	Nosepiece 18/53
8	143 6059	Steel head sleeve
9	143 6044	O-ring

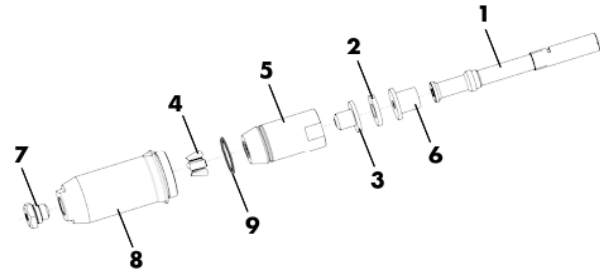

• Wearing parts

** For changing the complete set you have to order 4 Jaws

for 9.8mm (3/8") Magna-Lok® structure rivet

Article no. 145 8009

Spare part no.	Article no.	Designation
1	143 6065	Nozzle tube, complete
2	143 6064	Damping ring
3	143 6061	Jaw pusher
4 •	143 6066	Jaws, 3-part
5	143 6063	Jaw housing
6	143 6062	Centre part
7 •	143 6060	Nosepiece 18/63
8	143 6059	Steel head sleeve
9	143 6044	O-ring

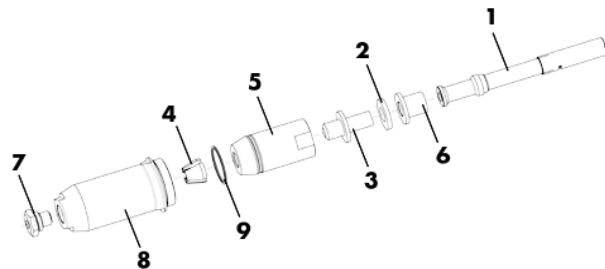

• Wearing parts

! The suitability of nosepiece and fastener needs to be tested by the user and is user's own responsibility!

Accessories for TAURUS® blind rivet setting tools

Angle heads for TAURUS® blind rivet setting tools

Angle head 90° compact for TAURUS® 1-2

Article no. 145 7921

Spare part no.	Article no.	Designation
1 •	143 4977	Nosepiece 17/36
2	143 5926	Steel head sleeve
3 •	143 5918	Jaw housing
4 •	143 4104	Jaws (3-part)
5 •	143 4992	Jaw Pusher
6 •	144 5747	Spring
7	145 0977	Housing
8	143 5911	Axis bolt
9	144 5545	Snap ring
10	143 5914	Spacer
11	143 5940	Lock activator
12	143 5935	Coupler
13	143 5936	Angle
14	143 5908	Bolt
15	143 5963	Protecting cap
16	144 6013	Screw
17	143 5938	Lock activator
18	143 5919	Fork head
19 •	144 6012	O-ring
20	143 5959	Adapter
21	143 5952	Ring

• Wearing parts

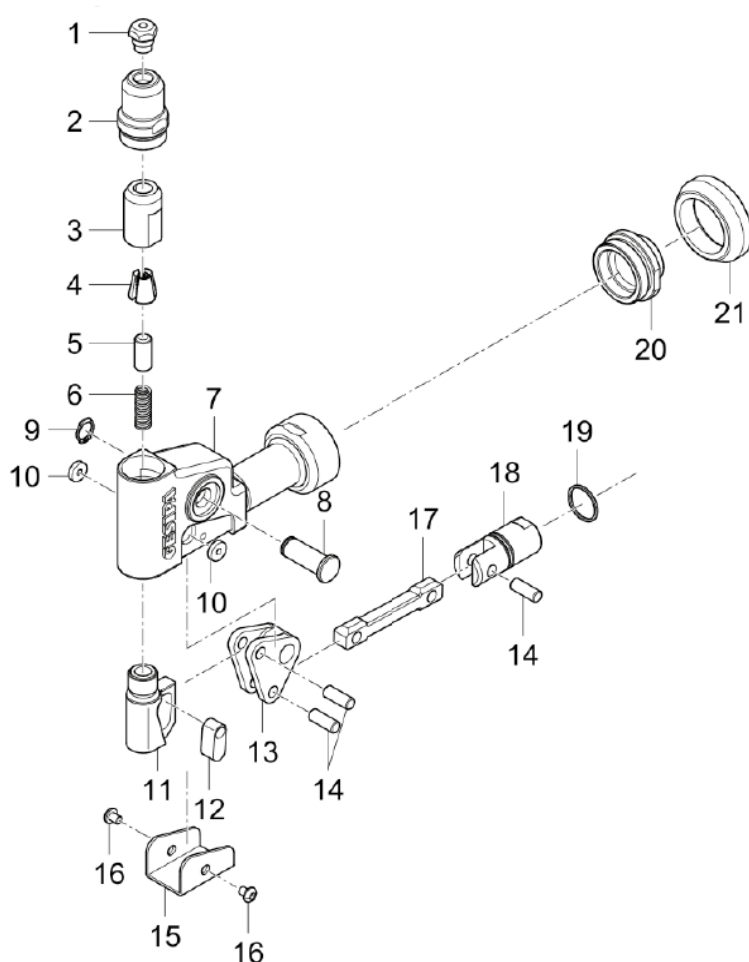

Accessories for TAURUS® blind rivet setting tools

Angle heads for TAURUS® blind rivet setting tools

Angle head 90° for TAURUS® 1- 4 (up to 31.01.2018)

Spare part no.	Article no.	Designation
1 •	143 4948	Nosepiece 17/45 Angle head
2	143 5955	Steel head sleeve
3 •	143 5946	Jaw housing
4 •	143 4173	Jaws (3-part)
	143 4958	Jaws (3-part) up to rivet Ø 4mm
5 •	143 4106	Jaw Pusher
6 •	144 5258	Spring
7	145 7961	Housing
8	143 5950	Axis bolt
9	144 6106	Snap ring
10	143 5947	Spacer
11	143 5949	Lock activator
12	143 5957	Angle
13	143 5948	Bolt
14	143 5954	Protecting cap
15	144 6013	Screw
16	143 5958	Lock activator
17	143 5951	Fork head
18 •	143 5603	O-ring
19	143 5959	Adapter
20	143 5952	Ring

• Wearing parts

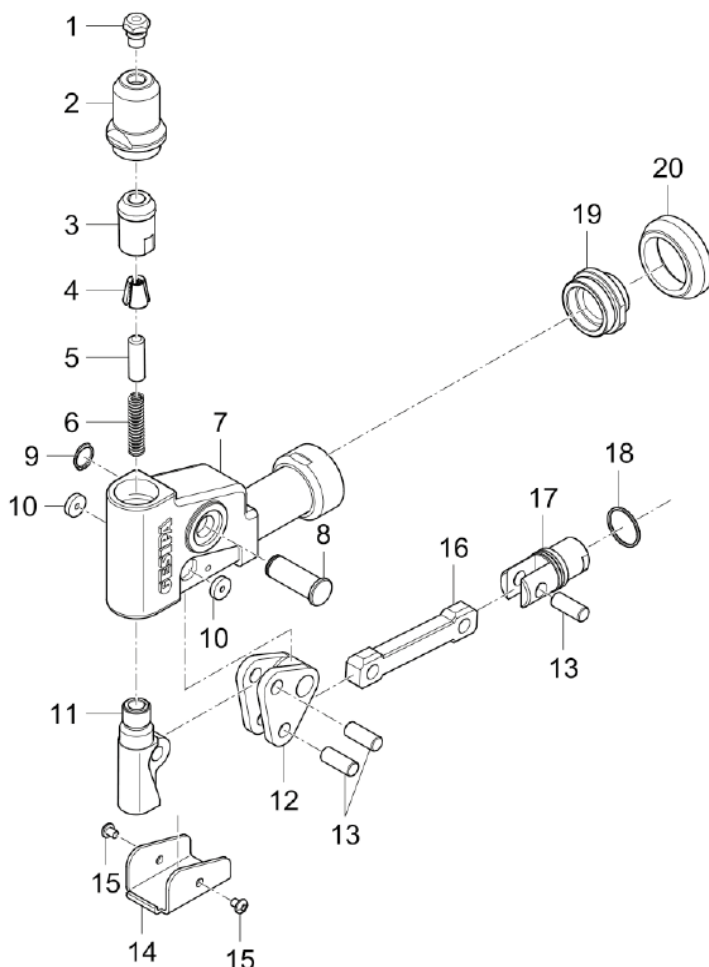

Accessories for TAURUS® blind rivet setting tools

Angle heads for TAURUS® blind rivet setting tools

Angle head 90° for TAURUS® 1,2, 4 & TAURUS® 3 (from 01.02.2018)

Spare part no.	TAURUS®-Type	Article no.	Designation
1 •		143 4948	Nosepiece 17/45 Angle head
2		143 5955	Steel head sleeve
3 •		143 5946	Jaw housing
4 •		143 4173	Jaws (3-part)
		143 4958	Jaws (3-part) up to rivet Ø 4mm (Nosepiece 17/24)
5 •		143 4106	Jaw Pusher
6 •		144 5258	Spring
7		145 7961	Housing
8		143 5950	Axis bolt
9		144 6106	Snap ring
10		143 5947	Spacer
11		155 9511	Lock activator
12		143 3543	Coupler
13	T1, T2, T4	155 9510	Angle
	T3	143 3544	Angle
14		143 5948	Bolt
15		143 5954	Protecting cap
16		144 6013	Screw
17	T1, T2, T4	143 5958	Lock activator
	T3	143 3545	Lock activator
18		143 5951	Fork head
19 •		143 5603	O-ring
20		143 5959	Adapler
21		143 5952	Ring

• Wearing parts

TAURUS® 1, 2, 4

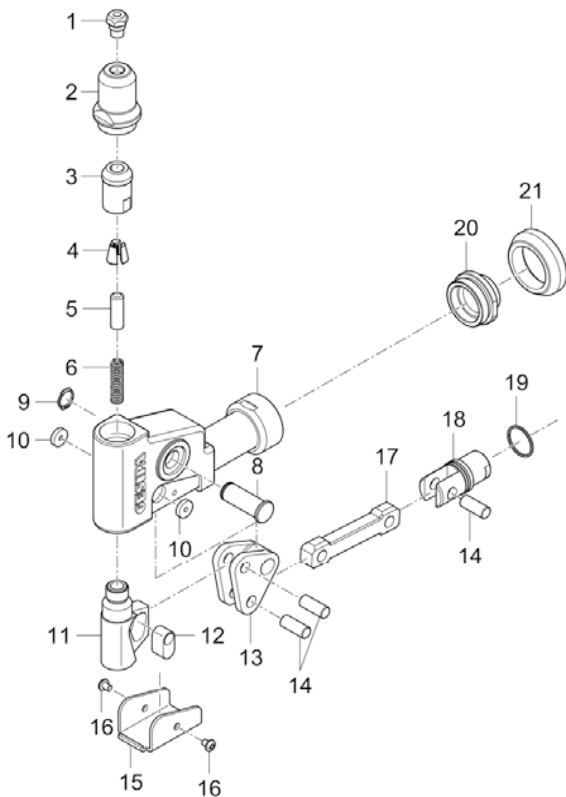

TAURUS® 3

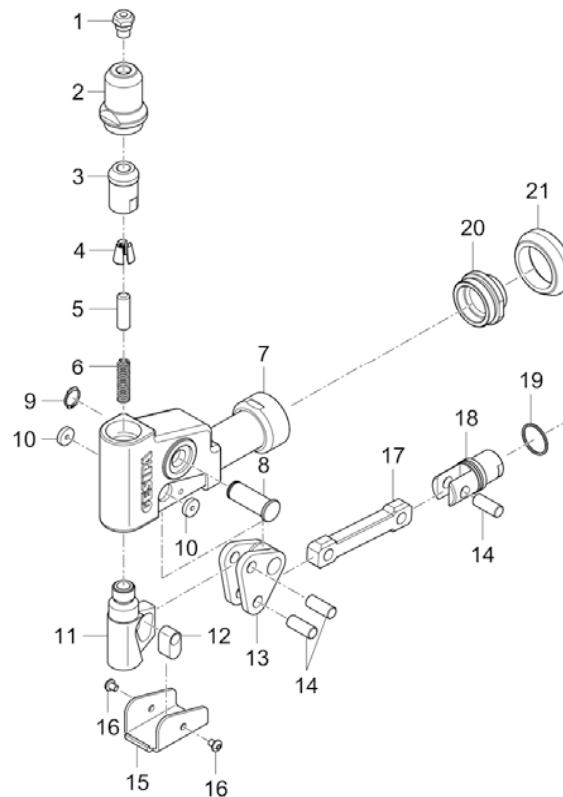

Hydro-pneumatic blind rivet setting tools

TAUREX 1-4

**Exploded drawing based on TAUREX 1.
Specifications of other models in the boxes.**

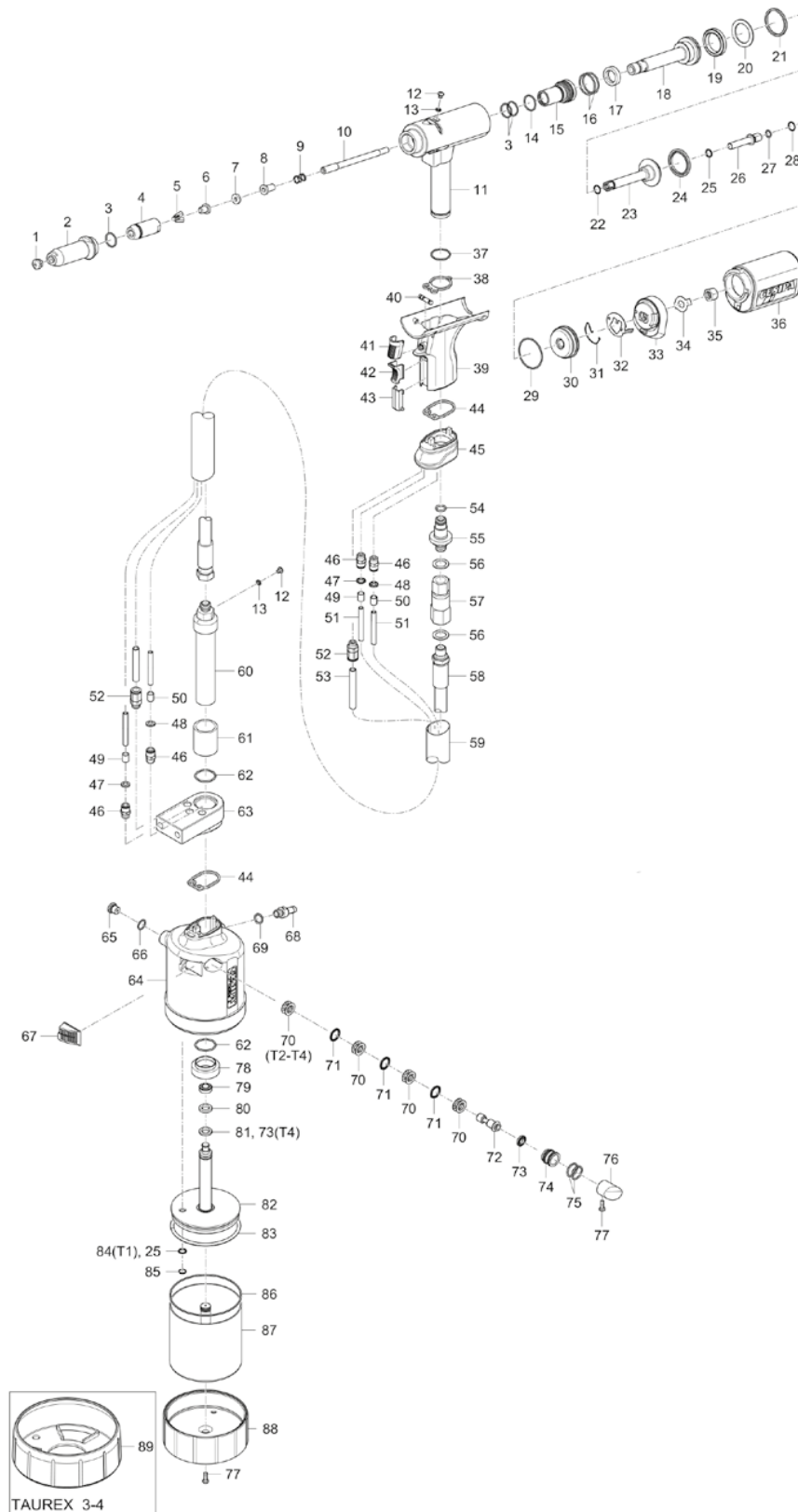

Hydro-pneumatic blind rivet setting tools

TAUREX 1-4

Spare part no.	TAURUS®-Type	Article no.	Designation
		143 4976	Nosepiece 17/18
	T1	143 4994	Nosepiece 17/20
		143 5018	Nosepiece 17/22
		143 4955	Nosepiece 17/24
	T2	143 4973	Nosepiece 17/27
		143 4974	Nosepiece 17/29
		143 4975	Nosepiece 17/32
		143 4977	Nosepiece 17/36
	T3, T4	143 4999	Nosepiece 17/40
		143 4860	Nosepiece 17/45
2		143 6003	Steel head sleeve 4
3 •		144 6012	O-ring
4 •		143 6002	Jaw housing 4
5 •		143 5568	Jaw 15°
	T1	143 5507	Jaw pusher AV1
	T2	143 5768	Jaw pusher AV2
	T3, T4	143 6000	Jaw pusher 4
7		143 5999	Damping ring 4
	T1	143 5509	Centre part AV1
	T2	143 5769	Centre part AV2
	T3, T4	143 6001	Centre part 4
9		146 3064	Spring
	T1	143 5558	Nozzle tube 1
	T2	143 5764	Nozzle tube 2, long
	T3, T4	143 5886	Nozzle tube 3, long
11		145 8029	Tool head, assembled
12		143 5612	Sealing ring M4
13		144 6013	Oil screw plug
14 •		143 5629	O-ring
15		143 5681	Seal holder, complete
16 •		143 4227	O-ring
17 •		143 5630	Rod seal
18		143 5631	Draw bar
19 •		143 5488	Supporting ring
20 •		143 5485	Piston seal
21 •		143 5632	Piston seal
22		143 5671	O-ring
23		145 7746	Resetting piston, complete
24 •		143 5633	Piston seal
25		143 5635	Rod seal
	T1	143 5852	Connecting piece 1
	T2, T3, T4	143 5765	Connecting piece 2/3
27		143 5519	O-ring
28		144 6167	Snap ring
29		143 5524	O-ring
30		143 5532	End cap
31		144 6028	Retaining spring
32		143 5664	Retainer
33		143 5663	Adapter
34		143 5842	Lock washer
	T1	143 5849	Supporting nut 1
	T2, T3, T4	143 5766	Supporting nut 2/3
36	T1, T2	143 5677	Spent mandrel container, complete
	T3, T4	143 5964	Spent mandrel container, complete
37		143 5590	O-ring
38 •		143 5472	Flat gasket 1
39		145 7748	Grip complete
40		145 7747	Distributing valve complete
41		144 6025	Activation button
42		143 5642	Valve
43		143 5686	Orifice
44 •		143 5480	Flat gasket 2
45		144 6126	Head adapter
46		144 6130	Screw-in connection
47		144 6132	Coding ring, green
48		144 6133	Coding ring, red
49		144 5393	PA tube Ø 6 green (L = 10 mm)*
50		144 5395	PA tube Ø 6 red (L = 10 mm)*
51		144 6134	PU tube Ø 6mm (L=3.2mm)
52		144 6138	Screw connection
53		144 6137	PU tube Ø 8mm (L=3.2mm)
54		143 4496	O-ring
55		143 6090	Hose connector

Spare part no.	TAURUS®-Type	Article no.	Designation
56		144 6131	Hydraulic seal rings
57		144 6146	Swivel
58		144 6127	Hydraulic hose
59		144 6135	Hose casing
	T1	151 3245	Hose connector cylinder
	T2, T3	151 3246	Hose connector cylinder
	T4	151 3247	Hose connector cylinder
60		143 6093	Spacer tube
	T1, T2, T3	143 6102	Spacer tube
	T4	143 6092	Cylinder adapter
61		143 5486	O-ring
	T1	145 1010	Air cylinder TAUREX 1
	T2	145 1012	Air cylinder TAUREX 2
	T3	143 6101	Air cylinder TAUREX 3
	T4	145 1024	Air cylinder TAUREX 4
65		145 7750	Pressure relief valve, complete
66		143 5484	O-ring
	T1	151 5051	Silencer 1, complete
	T2	145 7862	Silencer 2, complete
	T3, T4	145 7956	Silencer 3, complete
68		143 5667	Connecting nipple
69		144 6030	Sealing ring
70		143 5648	Spacer cage
71		143 5647	Rod seal
72		143 5651	Control piston
73		143 5675	Piston seal
74		143 5652	Piston seal
75		143 5688	O-ring
	T1	144 6026	Stopper 1
	T2	144 6073	Stopper 2
	T3, T4	144 6100	Stopper 3
77		144 5773	Housing screw short
78		143 5492	Al nut
	T1	143 5658	Piston seal
	T2, T3	143 5841	Piston seal
	T4	143 6007	Piston seal
	T1	143 5657	Guide ring 1
	T2, T3	143 5825	Guide ring 2
	T4	143 6006	Guide ring 4
	T1	143 5656	Piston seal
	T2, T3	143 5670	Piston seal
	T1	145 7751	Air piston 1, complete
	T2	145 7860	Air piston 2, complete
	T3	145 7952	Air piston 3, complete
	T4	145 7994	Air piston 4, complete
	T1	143 5660	O-ring
	T2	143 5834	O-ring
	T3, T4	143 5937	O-ring
	T1	143 5659	Rod seal
	T1	144 6027	Snap ring
	T2, T3, T4	144 6082	V-profile ring
	T1	143 5680	O-ring
	T2	143 5839	O-ring
	T3, T4	143 5927	O-ring
	T1	145 7752	Cylinder 1, complete
	T2	145 7861	Cylinder 2, complete
	T3	145 7953	Cylinder 3, complete
	T4	145 7995	Cylinder 4, complete
	T1	143 5508	Bottom 1
	T2	143 5761	Bottom 2
	T3, T4	143 5874	Bottom 3
	T3, T4	143 5900	Rubber foot 3-4
		144 5294	Hydraulic oil refill bottle, 100 ml

• Wearing parts

* The length required must always be specified on the order; the article numbers always refers to the price per metre.

Hydro-pneumatic blind rivet setting tools

TAUREX 5-6

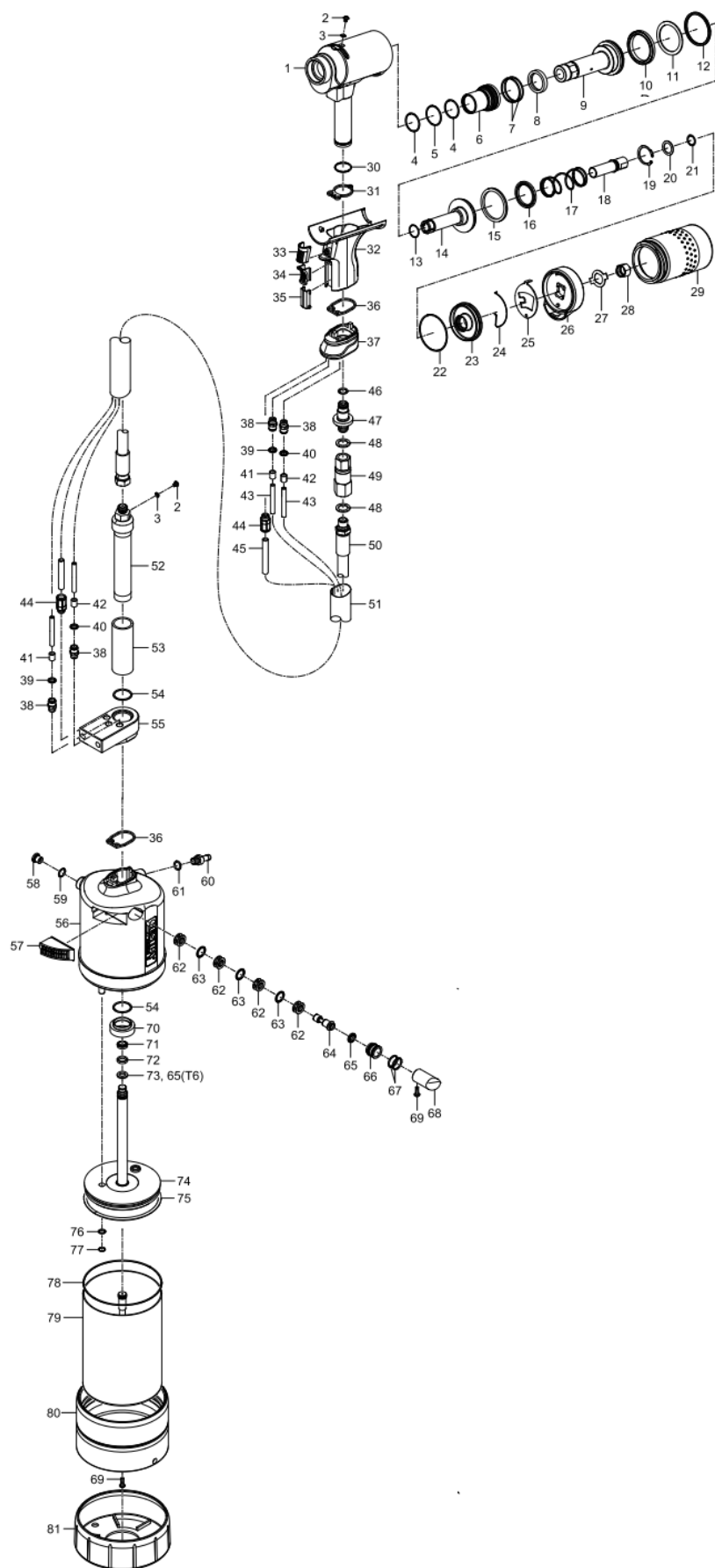

Hydro-pneumatic blind rivet setting tools

TAUREX 5-6

Spare part no.	TAURUS®-Type	Article no.	Designation
1		145 1025	Tool head, assembled
2		143 5612	Sealing ring M4
3		144 6013	Oil screw plug
4 •		143 6044	O-ring
5 •		143 6045	O-ring
6		143 6035	Seal holder, complete
7 •		143 6047	O-ring
8 •		143 6048	Rod seal
9		143 6036	Draw bar
10 •		143 6049	Cylinder seal
11 •		143 6052	Supporting ring
12 •		143 6051	Piston seal
13		143 6046	O-ring
14		145 8012	Resetting piston, complete
15 •		143 6050	Lip ring
16		143 6053	Rod seal
17		144 6123	Spring
18		143 6030	Connecting piece
19		144 6124	V-profile ring
20		144 6125	Washer
21		143 6042	O-ring
22		143 6043	O-ring
23		143 6034	End cap
24		144 6122	Retaining spring
25		143 6026	Retainer
26		143 6028	Adapter
27		143 6025	Lock washer
28		143 6029	Connecting piece nut
29		143 6058	Spent mandrel container, complete
30		143 5590	O-ring
31 •		143 5472	Flat gasket
32		145 7748	Grip complete
33		144 6025	Activation button
34		143 5642	Slider
35		143 5686	Orifice
36 •		143 5480	Flat gasket 2
37		144 6126	Head adapter
38		144 6130	Screw-in connection
39		144 6132	Coding ring, green
40		144 6133	Coding ring, red
41		144 5393	PA tube Ø 6 green (L = 10 mm)*
42		144 5395	PA tube Ø 6 red (L = 10 mm)*
43		144 6134	PU tube
44		144 6138	Screw connection
45		144 6137	PU tube
46		143 4496	O-ring

Spare part no.	TAURUS®-Type	Article no.	Designation
47		143 6090	Hose connector
48		144 6131	Hydraulic seal rings
49		144 6146	Swivel
50		144 6127	Hydraulic hose
51		144 6135	Hose casing
52	T5	152 4522	Hose connector cylinder
	T6	152 4523	Hose connector cylinder
53		143 6103	Spacer tube
54		143 5486	O-ring
55		143 6092	Cylinder adapter
56	T5	145 8013	Air cylinder TAUREX 5
	T6	146 4043	Air cylinder TAUREX 6
57		145 7956	Silencer 3, complete
58		145 7750	Pressure relief valve, complete
59		143 5484	O-ring
60		143 5667	Connecting nipple
61		144 6030	Seal
62		143 5648	Spacer cage
63		143 5647	Rod seal
64		143 5651	Control piston
65		143 5675	Piston seal
66		143 5652	Piston housing
67		143 5688	O-ring
68		144 6100	Stopper 3
69		144 5773	Housing screw, short
70		143 5492	Al nut
71 •	T5	143 6056	Cylinder seal
	T6	143 6007	Piston seal
72 •	T5	143 6040	Guide ring 5
	T6	143 6006	Guide ring 4
73 •	T5	143 6055	Lip ring
74	T5	145 8015	Air piston 5, complete
	T6	145 8024	Air piston 6, complete
75 •		143 5937	O-ring
76		143 5635	Rod seal
77		144 6082	V-profile ring
78		143 5927	O-ring
79	T5	145 8014	Cylinder 5, complete
	T6	146 4044	Cylinder 6, complete
80		143 6027	Al bottom
81		143 5900	Rubber foot 3-4
		144 5294	Hydraulic oil refill bottle, 100 ml

• Wearing parts

* The length required must always be specified on the order; the article numbers always refers to the price per metre.

Hydro-pneumatic blind rivet setting tools

TAURUS® 1-4 Axial eco

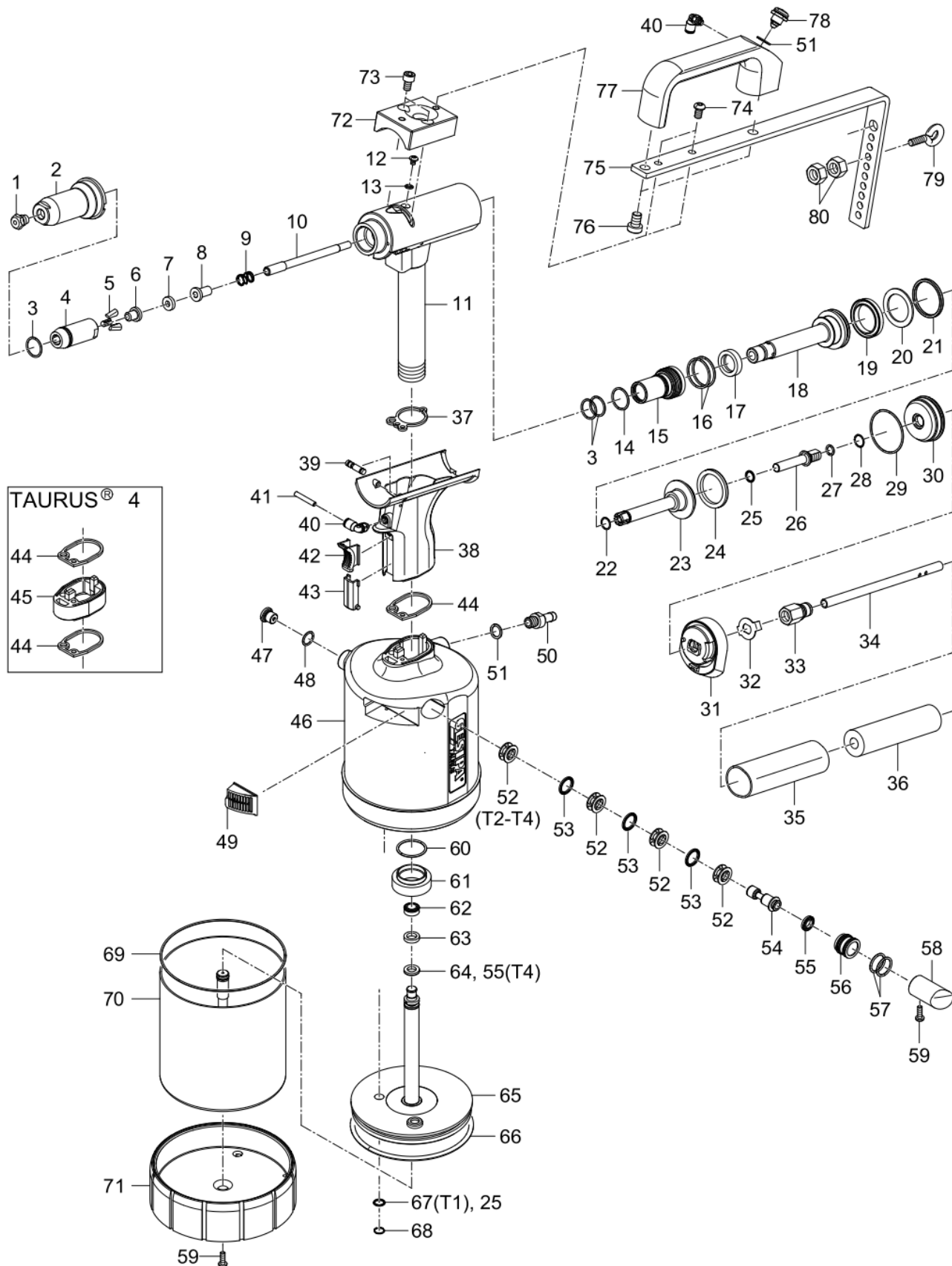

Hydro-pneumatic blind rivet setting tools

TAURUS® 1-4 Axial eco

Spare part no.	TAURUS®-Type	Article no.	Designation
		143 4976	Nosepiece 17/18
	T1	143 4994	Nosepiece 17/20
		143 5018	Nosepiece 17/22
		143 4955	Nosepiece 17/24
1	T2	143 4973	Nosepiece 17/27
		143 4974	Nosepiece 17/29
		143 4975	Nosepiece 17/32
		143 4977	Nosepiece 17/36
	T3	143 4999	Nosepiece 17/40
		143 4860	Nosepiece 17/45
2		143 6003	Steel head sleeve 4
3		144 6012	O-ring
4		143 6002	Jaw housing
5		143 5568	Jaws (3-part)
	T1	143 5507	Jaw pusher 1
	T2	143 5768	Jaw pusher 2
6	T3, T4	143 6000	Jaw pusher 4
7	T3, T4	143 5999	Damping ring 4
	T1	143 5509	Centre part 1
8	T2	143 5769	Centre part 2
	T3, T4	143 6001	Centre part 4
9		146 3064	Spring
	T1	143 5558	Nozzle tube 1
10	T2	143 5764	Nozzle tube 2, long
	T3, T4	143 5886	Nozzle tube 3, long
	T1	145 0876	Tool head 1, assembled
11	T2, T3	145 0934	Tool head 2, assembled
	T4	145 7999	Tool head 4, assembled
12		144 6013	Oil screw plug
13		143 5612	Sealing ring
14 •		143 5629	O-ring
15		143 5681	Seal holder, complete
16 •		143 4227	O-ring
17 •		143 5630	Rod seal
18		143 5631	Draw bar
19 •		143 5632	Piston seal
20 •		143 5488	Supporting ring
21 •		143 5485	Piston seal
22		143 5671	O-ring
23		145 7746	Resetting piston complete
24 •		143 5633	Piston seal
25	T2, T3, T4	143 5635	Rod seal
26	T1	143 5852	Connecting piece 1
	T2, T3, T4	143 5765	Connecting piece 2/3
27		143 5519	O-ring
28		144 6167	Snap ring
29		143 5524	O-ring
30		143 5532	End cap
31		143 5663	Adapter
32		143 5842	Lock washer
33		143 5848	Screw connection
34		143 5767	Hose
35		144 5647	Protective hose
36		143 5579	Foamed material tubes (0,1 m)*
37 •		143 5472	Flat gasket 1
38		145 7869	Grip FA, complete
39		145 7747	Distributing valve, complete
40		144 6230	Screw connection
41		144 6134	PU tube 0,2m*
42		143 5642	Slider
43		143 5686	Orifice
44 •		143 5480	Flat gasket 2
45	T4	143 5998	Grip extension
	T1	145 0883	Air cylinder 1 Axial eco
	T2	145 0942	Air cylinder 2 Axial eco
46	T3	145 0969	Air cylinder 3 Axial eco
	T4	145 0995	Air cylinder 4 Axial eco

Spare part no.	TAURUS®-Type	Article no.	Designation
47		145 7750	Pressure relief valve, complete
48		143 5484	O-ring
	T1	151 5051	Silencer 1, complete
49	T2	145 7862	Silencer 2, complete
	T3, T4	145 7956	Silencer 3, complete
50		143 5667	Connecting nipple
51		144 6030	Sealing ring
52		143 5648	Spacer cage
53		143 5647	Rod seal
54		143 5651	Control piston
55		143 5675	Piston seal
56		143 5652	Piston housing
57		143 5688	O-ring
	T1	144 6026	Stopper 1
58	T2	144 6073	Stopper 2
	T3, T4	144 6100	Stopper 3
59		144 5773	Housing screw, short
60		143 5486	O-ring
61		143 5492	Al nut
	T1	143 5658	Piston seal
62	T2, T3	143 5841	Piston seal
	T1	143 6007	Piston seal
	T1	143 5657	Guide ring 1
63	T2, T3	143 5825	Guide ring 2
	T4	143 6006	Guide ring 4
64	T1	143 5656	Piston seal
	T2, T3	143 5670	Piston seal
	T1	145 7751	Air piston 1, complete
	T2	145 7860	Air piston 2, complete
65	T3	145 7952	Air piston 3, complete
	T4	145 7994	Air piston 4, complete
	T1	143 5660	O-ring
66	T2	143 5834	O-ring
	T3, T4	143 5937	O-ring
67	T1	143 5659	Rod seal
68	T1	144 6027	Snap ring
	T2, T3, T4	144 6082	V-profile ring
	T1	143 5680	O-ring
69	T2	143 5839	O-ring
	T3, T4	143 5927	O-ring
	T1	145 7752	Cylinder 1, complete
	T2	145 7861	Cylinder 2, complete
70	T3	145 7953	Cylinder 3, complete
	T4	145 7995	Cylinder 4, complete
	T1	143 5508	Bottom 1
71	T2	143 5761	Bottom 2
	T3, T4	143 5874	Bottom 3
72		143 5538	Holder
73		144 5630	Allen screw
74		144 6087	Fillister head screw
75		143 5836	Hanger
76		144 6085	Allen screw
77		143 5575	Grip
78		145 6753	Valve, complete
79		144 5342	Screw
80		144 5262	Nut
		144 5294	Hydraulic oil refill bottle, 100 ml

• Wearing parts

* The length required must always be specified on the order; the article numbers always refers to the price per metre.

Hydro-pneumatic blind rivet setting tools

TAURUS® 1-4 Axial (up to and including September 2015)

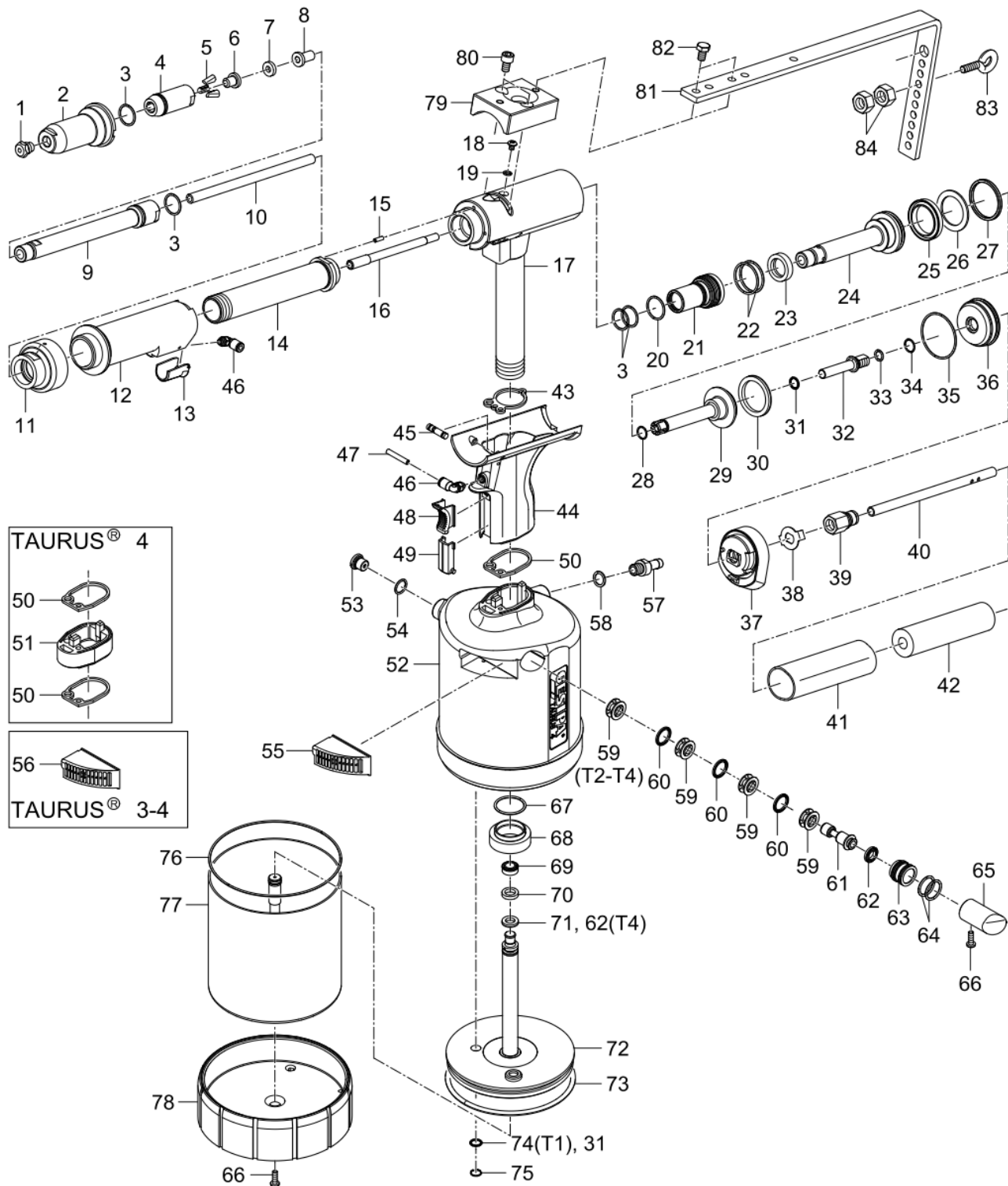

Hydro-pneumatic blind rivet setting tools

TAURUS® 1-4 Axial (up to and including September 2015)

Spare part no.	TAURUS®-Type	Article no.	Designation
		143 4976	Nosepiece 17/18
	T1	143 4994	Nosepiece 17/20
		143 5018	Nosepiece 17/22
		143 4955	Nosepiece 17/24
1 •	T2	143 4973	Nosepiece 17/27
		143 4974	Nosepiece 17/29
		143 4975	Nosepiece 17/32
		143 4977	Nosepiece 17/36
	T3	143 4999	Nosepiece 17/40
		143 4860	Nosepiece 17/45
2		143 6003	Steel head sleeve 4
3 •		144 6012	O-ring
4 •		143 6002	Jaw housing
5 •		143 5568	Jaw (3-part)
	T1	143 5507	Jaw pusher 1
6	T2	143 5768	Jaw pusher 2
	T3, T4	143 6000	Jaw pusher 4
7		143 5999	Damping ring 4
	T1	143 5509	Centre part 1
8	T2	143 5769	Centre part 2
	T3, T4	143 6001	Centre part 4
9		143 5863	Adapter, ext. 150mm
10	T1	143 5867	Adapter 1, ext. 150mm
11		143 5856	Adapter
12		145 7865	Grip
13		144 6025	Activation button
14		143 5857	Spacer
15		144 6091	Cylinder pin
	T1	143 5558	Nozzle tube 1
16	T2	143 5764	Nozzle tube 2, long
	T3, T4	143 5886	Nozzle tube 3, long
	T1	145 7866	Tool head 1, assembled
17	T2, T3	145 7867	Tool head 2, assembled
	T4	145 7868	Tool head 4, assembled
18		144 6013	Oil screw plug
19		143 5612	Sealing ring M4
20 •		143 5629	O-ring
21		143 5681	Seal holder, complete
22 •		143 4227	O-ring
23 •		143 5630	Rod seal
24		143 5631	Draw bar
25 •		143 5632	Piston seal
26 •		143 5488	Supporting ring
27 •		143 5485	Piston seal
28		143 5671	O-ring
29		145 7746	Resetting piston, complete
30 •		143 5633	Piston seal
31	T2, T3, T4	143 5635	Rod seal
32	T1	143 5852	Connecting piece 1
	T2, T3, T4	143 5765	Connecting piece 2/3
33		143 5519	O-ring
34		144 6167	Snap ring
35		143 5524	O-ring
36		143 5532	End cap
37		143 5663	Adapter
38		143 5842	Lock washer
39		143 5848	Screw connection
40		143 5767	Hose
41		144 5647	Protective hose
42		143 5579	Foamed material tubes (0, 1m)
43 •		143 5472	Flat gasket 1
44		145 7869	Grip FA, complete
45		145 7747	Distributing valve, complete
46		144 6230	Screw connection
47		144 6134	Tube*
48		143 5642	Slider

Spare part no.	TAURUS®-Type	Article no.	Designation
49		143 5686	Orifice
50 •		143 5480	Flat gasket 2
51	T4	143 5998	Grip extension
	T1	145 0882	Air cylinder 1 Axial
52	T2	145 0941	Air cylinder 2 Axial
	T3	145 0968	Air cylinder 3 Axial
	T4	145 0994	Air cylinder 4 Axial
53		145 7750	Pressure relief valve, complete
54		143 5484	O-ring
55	T2	145 7862	Silencer 2, complete
56	T3, T4	145 7956	Silencer 3, complete
57		143 5667	Connecting nipple
58		144 6030	Sealing ring
59		143 5648	Spacer cage
60		143 5647	Rod seal
61		143 5651	Control piston
62 •		143 5675	Piston seal
63		143 5652	Piston housing
64		143 5688	O-ring
	T1	144 6026	Stopper 1
65	T2	144 6073	Stopper 2
	T3, T4	144 6100	Stopper 3
66		144 5773	Housingscrew, short
67		143 5486	O-ring
68		143 5492	Al nut
	T1	143 5658	Piston seal
69 •	T2, T3	143 5841	Piston seal
	T4	143 6007	Piston seal
	T1	143 5657	Guide ring 1
70 •	T2, T3	143 5825	Guide ring 2
	T4	143 6006	Guide ring 3
71 •	T1	143 5656	Piston seal
	T2, T3	143 5670	Piston seal
	T1	145 7751	Air piston 1, complete
72	T2	145 7860	Air piston 2, complete
	T3	145 7952	Air piston 3, complete
	T4	145 7994	Air piston 4, complete
	T1	143 5660	O-ring
73 •	T2	143 5834	O-ring
	T3, T4	143 5937	O-ring
74	T1	143 5659	Rod seal
75	T1	144 6027	Snap ring
	T2, T3, T4	144 6082	V-profile ring
	T1	143 5680	O-ring
76	T2	143 5839	O-ring
	T3, T4	143 5927	O-ring
	T1	145 7752	Cylinder 1, complete
77	T2	145 7861	Cylinder 2, complete
	T3	145 7953	Cylinder 3, complete
	T4	145 7995	Cylinder 4, complete
	T1	143 5508	Bottom 1
78	T2	143 5761	Bottom 2
	T3, T4	143 5874	Bottom 3
79		143 5538	Holder
80		144 5630	Allen screw
81		143 5855	Hanger
82		144 6092	Hexagon head screw
83		144 5342	Screw
84		144 5262	Nut
		144 5294	Hydraulic oil refill bottle, 100 ml

• Wearing parts

* The length required must always be specified on the order; the article numbers always refers to the price per metre.

Hydro-pneumatic blind rivet setting tools

TAURUS® 1-4 Axial (from October 2015)

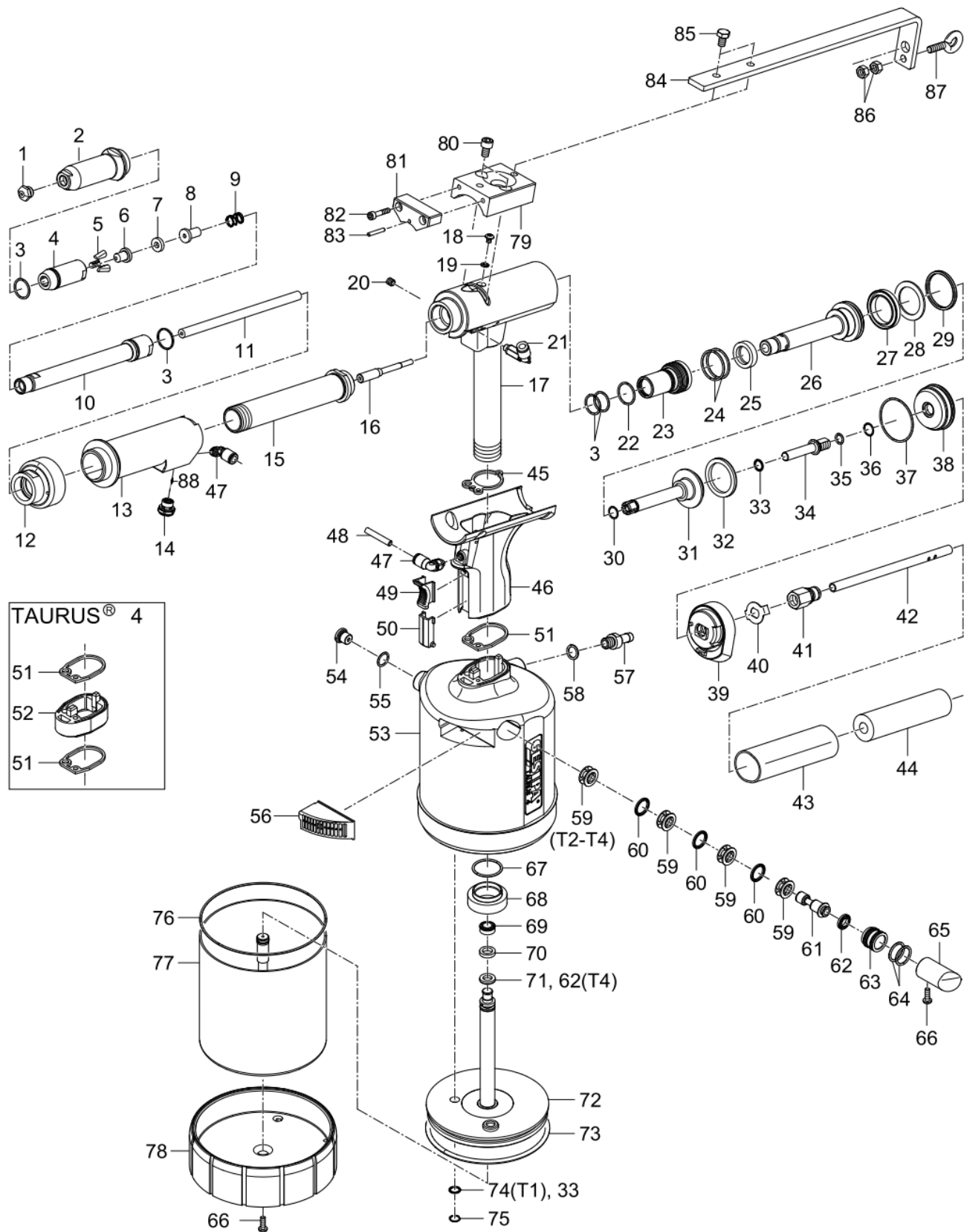

Hydro-pneumatic blind rivet setting tools

TAURUS® 1-4 Axial (from October 2015)

Spare part no.	TAURUS®-Type	Article no.	Designation
		143 4976	Nosepiece 17/18
	T1	143 4994	Nosepiece 17/20
		143 5018	Nosepiece 17/22
		143 4955	Nosepiece 17/24
1 •	T2	143 4973	Nosepiece 17/27
		143 4974	Nosepiece 17/29
		143 4975	Nosepiece 17/32
		143 4977	Nosepiece 17/36
	T3	143 4999	Nosepiece 17/40
		143 4860	Nosepiece 17/45
2		143 6003	Steel head sleeve 4
3 •		144 6012	O-ring
4 •		143 6002	Jaw housing
5 •		143 5568	Jaw (3-part)
	T1	143 5507	Jaw pusher 1
6	T2	143 5768	Jaw pusher 2
	T3, T4	143 6000	Jaw pusher 4
7		143 5999	Damping ring 4
	T1	143 5509	Centre part 1
8	T2	143 5769	Centre part 2
	T3, T4	143 6001	Centre part 4
9		146 3064	Spring
10		143 5863	Adapter, ext. 150mm
11	T1	143 5867	Adapter 1, ext. 150mm
12		143 5856	Adapter
13		143 6915	Grip Axial complete
14		143 6481	Trip valve
15		143 5857	Spacer
	T1	143 5558	Nozzle tube 1
16	T2	143 5764	Nozzle tube 2, long
	T3, T4	143 5886	Nozzle tube 3, long
	T1	143 6479	Tool head 1, assembled
17	T2, T3	143 6476	Tool head 2, assembled
	T4	143 6422	Tool head 4, assembled
18		144 6013	Oil screw plug
19		143 5612	Sealing ring M4
20		145 2756	Stud bolt
21		145 2755	Screw connection
22 •		143 5629	O-ring
23		143 5681	Seal holder, complete
24		143 4227	O-ring
25		143 5630	Rod seal
26		143 5631	Draw bar
27		143 5632	Piston seal
28		143 5488	Supporting ring
29		143 5485	Piston seal
30		143 5671	O-ring
31		145 7746	Resetting piston, complete
32		143 5633	Piston seal
33		143 5635	Rod seal
	T1	143 5852	Connecting piece 1
34	T2, T3, T4	143 5765	Connecting piece 2/3
35		143 5519	O-ring
36		144 6167	Snap ring
37		143 5524	O-ring
38		143 5532	End cap
39		143 5663	Adapter
40		143 5842	Lock washer
41		143 5848	Screw connection
42		143 5767	Hose
43		144 5647	Protective hose
44		143 5579	Foamed material tubes (0, 1m)
45		143 5472	Flat gasket 1
46		143 6480	Grip FA, complete
47		144 6230	Screw connection
48		144 6134	Tube 0, 1m*

Spare part no.	TAURUS®-Type	Article no.	Designation
49		143 5642	Slider
50		143 5686	Orifice
51		143 5480	Flat gasket 2
52	T4	143 5998	Grip extension
	T1	145 0882	Air cylinder 1 Axial
53	T2	145 0941	Air cylinder 2 Axial
	T3	145 0968	Air cylinder 3 Axial
	T4	145 0994	Air cylinder 4 Axial
54		145 7750	Pressure relief valve, complete
55		143 5484	O-ring
	T1	151 5051	Silencer 1, complete
56	T2	145 7862	Silencer 2, complete
	T3, T4	145 7956	Silencer 3, complete
57		143 5667	Connecting nipple
58		144 6030	Sealing ring
59		143 5648	Spacer cage
60		143 5647	Rod seal
61		143 5651	Control piston
62		143 5675	Piston seal
63		143 5652	Piston housing
64		143 5688	O-ring
	T1	144 6026	Stopper 1
65	T2	144 6073	Stopper 2
	T3, T4	144 6100	Stopper 3
66		144 5773	HousingsScrew, short
67		143 5486	O-ring
68		143 5492	Al nut
	T1	143 5658	Piston seal
69	T2, T3	143 5841	Piston seal
	T4	143 6007	Piston seal
	T1	143 5657	Guide ring 1
70	T2, T3	143 5825	Guide ring 2
	T4	143 6006	Guide ring 3
71	T1	143 5656	Piston seal
	T2, T3	143 5670	Piston seal
	T1	145 7751	Air piston 1, complete
72	T2	145 7860	Air piston 2, complete
	T3	145 7952	Air piston 3, complete
	T4	145 7994	Air piston 4, complete
	T1	143 5660	O-ring
73	T2	143 5834	O-ring
	T3, T4	143 5937	O-ring
74	T1	143 5659	Rod seal
75	T1	144 6027	Snap ring
	T2, T3, T4	144 6082	V-profile ring
	T1	143 5680	O-ring
76	T2	143 5839	O-ring
	T3, T4	143 5927	O-ring
	T1	145 7752	Cylinder 1, complete
77	T2	145 7861	Cylinder 2, complete
	T3	145 7953	Cylinder 3, complete
	T4	145 7995	Cylinder 4, complete
	T1	143 5508	Bottom 1
78	T2	143 5761	Bottom 2
	T3, T4	143 5874	Bottom 3
79		143 5538	Holder
80		144 5630	Allen screw
81		145 0895	Holder
82		145 2757	Allen screw
83		143 3954	Cylinder pin
84		143 5836	Hanger
85		144 6092	Hexagon head screw
86		144 5262	Nut
87		144 5342	Screw
		144 5294	Hydraulic oil refill bottle, 100 ml

* Wearing parts

* The length required must always be specified on the order; the article numbers always refers to the price per metre.

Hydro-pneumatic blind rivet setting tools

TAUREX 1-4 Axial

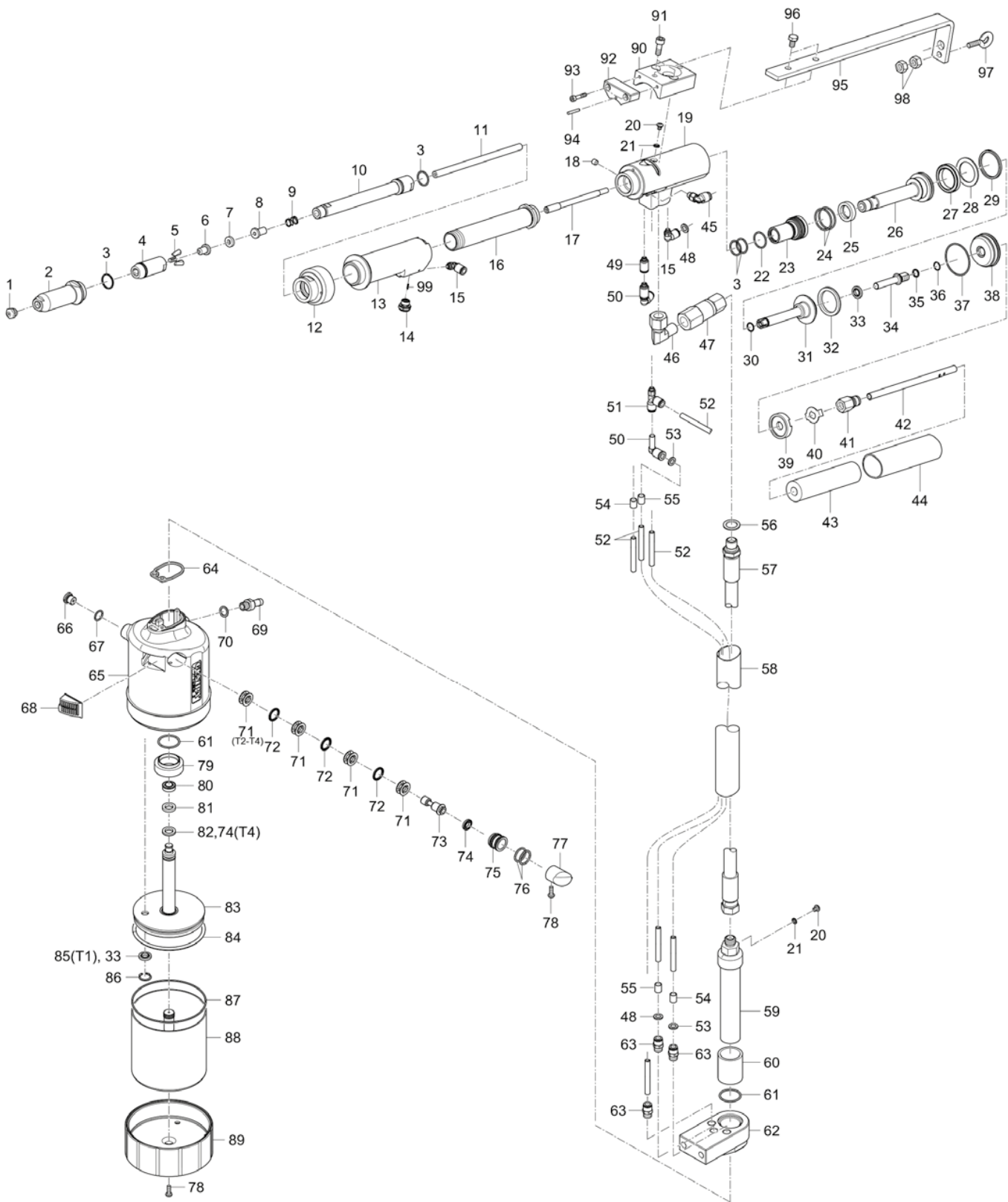

Hydro-pneumatic blind rivet setting tools

TAUREX 1-4 Axial

Spare part no.	TAURUS®-Type	Article no.	Designation
1	T1	143 4976	Nosepiece 17/18
		143 4994	Nosepiece 17/20
		143 5018	Nosepiece 17/22
		143 4955	Nosepiece 17/24
		143 4973	Nosepiece 17/27
	T2	143 4974	Nosepiece 17/29
		143 4975	Nosepiece 17/32
		143 4977	Nosepiece 17/36
	T3, T4	143 4999	Nosepiece 17/40
		143 4860	Nosepiece 17/45
2		143 6003	Steel head sleeve 4
3		144 6012	O-ring
4		143 6002	Jaw housing 4
5		143 5568	Jaws (3-part)
6	T1	143 5507	Jaw Pusher 1
	T2	143 5768	Jaw Pusher 2
	T3, T4	143 6000	Jaw Pusher 4
		143 5999	Damping ring 4
8	T1	143 5509	Centre part 1
	T2	143 5769	Centre part 2
	T3, T4	143 6001	Centre part 4
		146 3064	Spring
10		143 5863	Adapter
11	T1	143 5867	Adapter 1
	T2	143 5862	Adapter 2
	T3, T4	143 5868	Adapter 3
		143 5856	Adapter
13		145 2757	Grip Axial, complete
14		143 6481	Release valve
15		144 6230	Screw connection
16		143 5857	Spacer
17	T1	143 5558	Nozzle tube 1
	T2	143 5764	Nozzle tube 2, long
	T3, T4	143 5886	Nozzle tube 3, long
		145 2756	Stud bolt
19		145 0948	Tool head, assembled
20		144 6013	Oil screw plug
21		143 5612	Sealing ring M4
22		143 5629	O-ring
23		143 5628	Seal holder, complete
24		143 4227	O-ring
25		143 5630	Rod seal
26		143 5631	Draw bar
27		143 5632	Piston seal
28		143 5488	Supporting ring
29		143 5485	Piston seal
30		145 7746	Resetting piston, complete
31		143 5671	O-ring
32		143 5633	Piston seal
33		143 5635	Rod seal
34	T1	143 5852	Connecting piece 1
	T2, T3, T4	143 5765	Connecting piece 2/3
		143 5519	O-ring
36		144 6167	Snap ring
37		143 5524	O-ring
38		143 5532	End cap
39		143 5853	Supporting ring
40		143 5842	Lock washer
41		143 5848	Screw connection
42		143 5767	Hose
43		143 5579	Foamed material tubes
44		144 5647	Protective hose
45		144 6017	Elbow union
46		144 6145	Elbow union
47		144 6146	Swivel
48		144 6132	Coding ring, green
49		144 6095	Screw connection
50		145 2759	Plug-in coupling
51		144 6093	Screw connection
52		144 6134	PU tube (0,16m)
		144 6134	PU tube (1,7m)

Spare part no.	TAURUS®-Type	Article no.	Designation
53		144 6133	Coding ring, red
54		144 5393	PA tube green (0,01m)
55		144 5395	PA tube red (0,01m)
56		144 6131	Sealing ring
57		144 6136	Hydraulic hose
58		144 6135	Protective hose
59	T1	151 3245	Hose connector
	T2, T3	151 3246	Hose connector
		T4	151 3247
60	T1, T2, T3	143 6093	Spacer tube
		T4	143 6102
61		143 5486	O-ring
62		143 6092	Cylinder adapter
63		144 6130	Screw connection
64		143 5480	Flat gasket
65	T1	148 8025	Air cylinder 1, complete
	T2	148 8026	Air cylinder 2, complete
	T3	148 8027	Air cylinder 3, complete
	T4	148 8029	Air cylinder 4, complete
66		145 7750	Pressure relief valve
67		143 5484	O-ring
68	T1	151 5051	Silencer complete
	T2	145 7862	Silencer complete
	T3, T4	145 7956	Silencer complete
		143 5667	Connecting nipple
70		144 6030	Sealing ring
71		143 5648	Spacer ring
72		143 5647	Rod seal
73		143 5651	Control piston
74		143 5675	Piston seal
75		143 5652	Piston housing
76		143 5688	O-ring
77	T1	144 6026	Stopper 1
	T2	144 6073	Stopper 2
	T3, T4	144 6100	Stopper 3
		144 5773	Screw
79		143 5492	Alu nut
80	T1	143 5658	Piston seal
	T2, T3	143 5595	Piston seal
		T4	143 6007
81	T1	143 5657	Guide ring 1
	T2, T3	143 5825	Guide ring 2
		T4	143 6006
	82	T1	143 5656
T2, T3		143 5670	Piston seal
		T1	145 7751
83	T2	145 7860	Air piston 2 complete
	T3	145 7952	Air piston 3 complete
	T4	145 7994	Air piston 4 complete
		T1	143 5660
84	T2	143 5834	O-ring
	T3, T4	143 5937	O-ring
		T1	143 5659
86	T1	144 6027	Snap ring
	T2, T3, T4	144 6082	Snap ring
T1		143 5680	O-ring
87	T2	143 5839	O-ring
	T3, T4	143 5927	O-ring
		T1	145 7752
88	T2	145 7861	Cylinder 2 complete
	T3	145 7953	Cylinder 3 complete
	T4	145 7995	Cylinder 4 complete
		T1	143 5508
89	T2	143 5761	Bottom 2
	T3, T4	143 5874	Bottom 3
			143 5538
91		144 5630	Allen screw
92		145 0895	Holder
93		143 6915	Allen screw
94		143 3954	Cylinder pin
95		143 5855	Hanger
96		144 6092	Hexagon head screw
97		144 5342	Screw
98		144 5262	Nut
99		144 5996	Spring
100		144 5294	Hydraulic oil refill bottle 100ml

Hydro-pneumatic blind rivet setting tools

Spring-loaded trigger system for TAURUS® 1-4 Axial eco

Spare part no.	TAURUS®-Type	Article no.	Designation
1 •	T1	143 5591	Nosepiece 17/18 AV
		143 4990	Nosepiece 17/20 AV
		143 4991	Nosepiece 17/22 AV
		143 5592	Nosepiece 17/24 AV
		143 5593	Nosepiece 17/27 AV
	T2	143 5594	Nosepiece 17/29 AV
		143 5595	Nosepiece 17/32 AV
		143 5596	Nosepiece 17/36 AV
	T3, T4	143 5597	Nosepiece 17/40 AV
		143 5598	Nosepiece 17/45 AV
143 5466		Steel head sleeve	
2	T1	145 0887	Support sleeve AV, complete
3	T2	145 0943	Support sleeve AV, complete
	T3, T4	145 0978	Support sleeve AV, complete
4		143 5499	Union nut
5 •		144 6012	O-ring
6 •		143 6002	Jaw housing 4
7 •		143 5568	Jaws (3-part)
8	T1	143 5507	Jaw pusher 1
	T2	143 5768	Jaw pusher 2
	T3, T4	143 6000	Jaw pusher 4

Spare part no.	TAURUS®-Type	Article no.	Designation
9		143 5999	Damping ring 4
10	T1	143 5509	Centre part 1
	T2	143 5769	Centre part 2
	T3, T4	143 6001	Centre part 4
11		146 3064	Spring
12		144 5994	Spring
13		144 5995	Allen screw
14		152 4521	Stamp
15		143 5498	Casing
16		143 5529	O-ring
17		144 6010	Snap ring
18	T1	143 5599	Nosepiece Ø 2,5
	T2	143 5600	Nosepiece Ø 3,2
	T3, T4	143 5601	Nosepiece Ø 4,5
19		143 5467	Support sleeve

- Wearing parts
- * The spring has been installed since 08.09.2015.

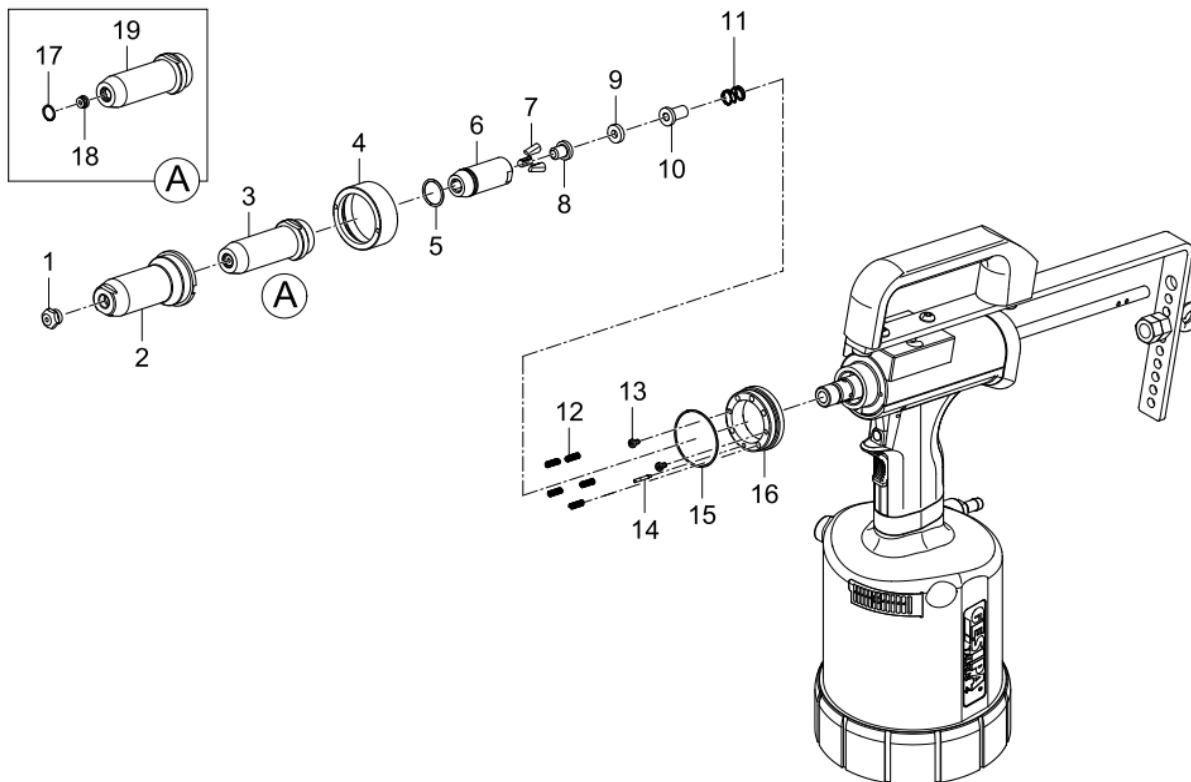

Hydro-pneumatic blind rivet setting tools

Spring-loaded trigger system for TAURUS® 1-4 Axial

Spare part no.	TAURUS®-Type	Article no.	Designation
1 •	T1	143 5591	Nosepiece 17/18 AV
		143 4990	Nosepiece 17/20 AV
		143 4991	Nosepiece 17/22 AV
		143 5592	Nosepiece 17/24 AV
		143 5593	Nosepiece 17/27 AV
	T2	143 5594	Nosepiece 17/29 AV
		143 5595	Nosepiece 17/32 AV
		143 5596	Nosepiece 17/36 AV
		143 5597	Nosepiece 17/40 AV
		143 5598	Nosepiece 17/45 AV
	T3, T4	143 5466	Steel head sleeve
		145 0887	Support sleeve AV, complete
		145 0943	Support sleeve AV, complete
2	T1	145 0978	Support sleeve AV, complete
3	T2	145 0978	Support sleeve AV, complete
3	T3, T4	145 0978	Support sleeve AV, complete
4		143 5499	Union nut
5 •		144 6012	O-ring
6 •		143 6002	Jaw housing 4
7 •		143 5568	Jaws (3-part)
8	T1	143 5507	Jaw pusher 1
	T2	143 5768	Jaw pusher 2
	T3, T4	143 6000	Jaw pusher 4

Spare part no.	TAURUS®-Type	Article no.	Designation
9		143 5999	Damping ring 4
10	T1	143 5509	Centre part 1
	T2	143 5769	Centre part 2
	T3, T4	143 6001	Centre part 4
11		146 3064*	Spring
12	T1	143 5867	Adapter 1
	T2	143 5862	Adapter 2
	T3, T4	143 5868	Adapter 3
13		143 5863	Adapter, ext. 150mm
14		144 6097	Allen screw
15		144 5994	Spring
16		145 0947	Valve body, complete
17		143 5866	Rod seal
18		144 6010	Snap ring
19	T1	143 5599	Nosepiece Ø 2,5
20	T2	143 5600	Nosepiece Ø 3,2
21	T3, T4	143 5601	Nosepiece Ø 4,5
22		143 5467	Support sleeve

• Wearing parts

* The spring has been installed since 08.09.2015.

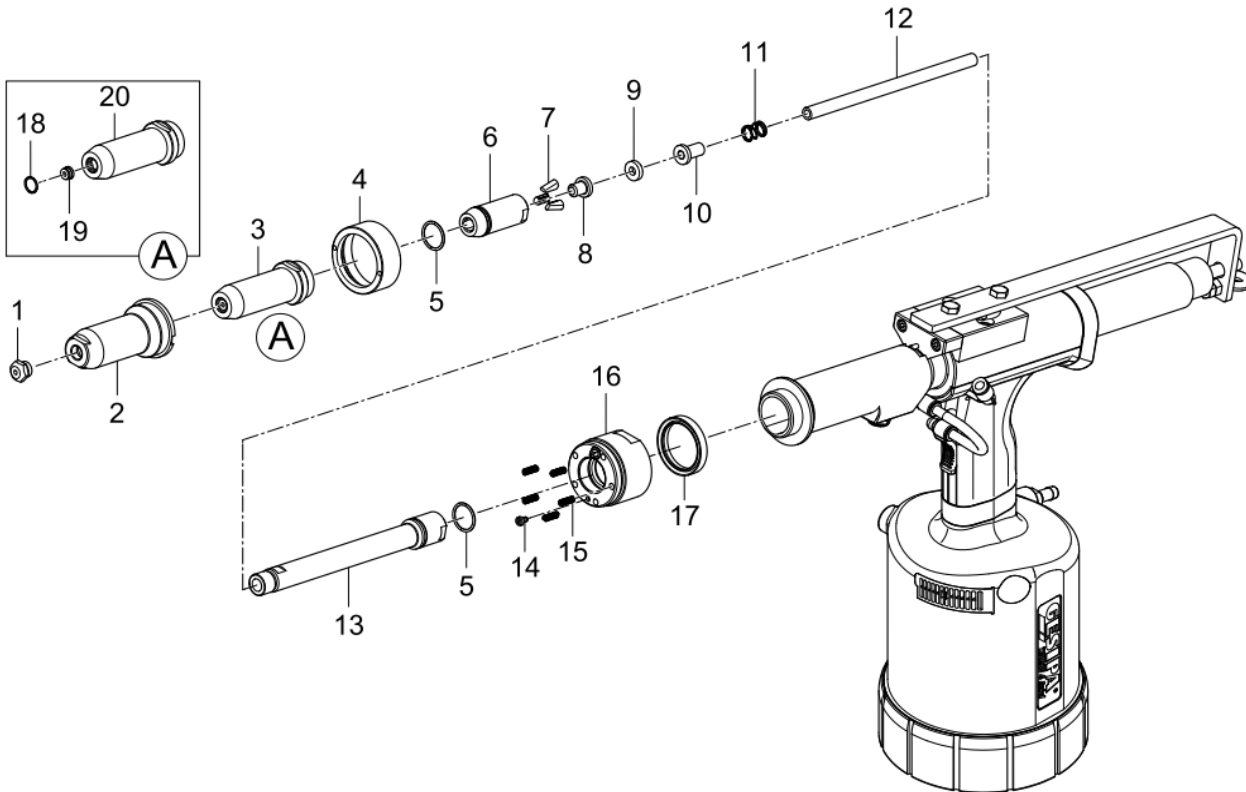

Hydro-pneumatic blind rivet setting tools

TAURUS® 1 Speed Rivet / TAURUS® 2 Speed Rivet

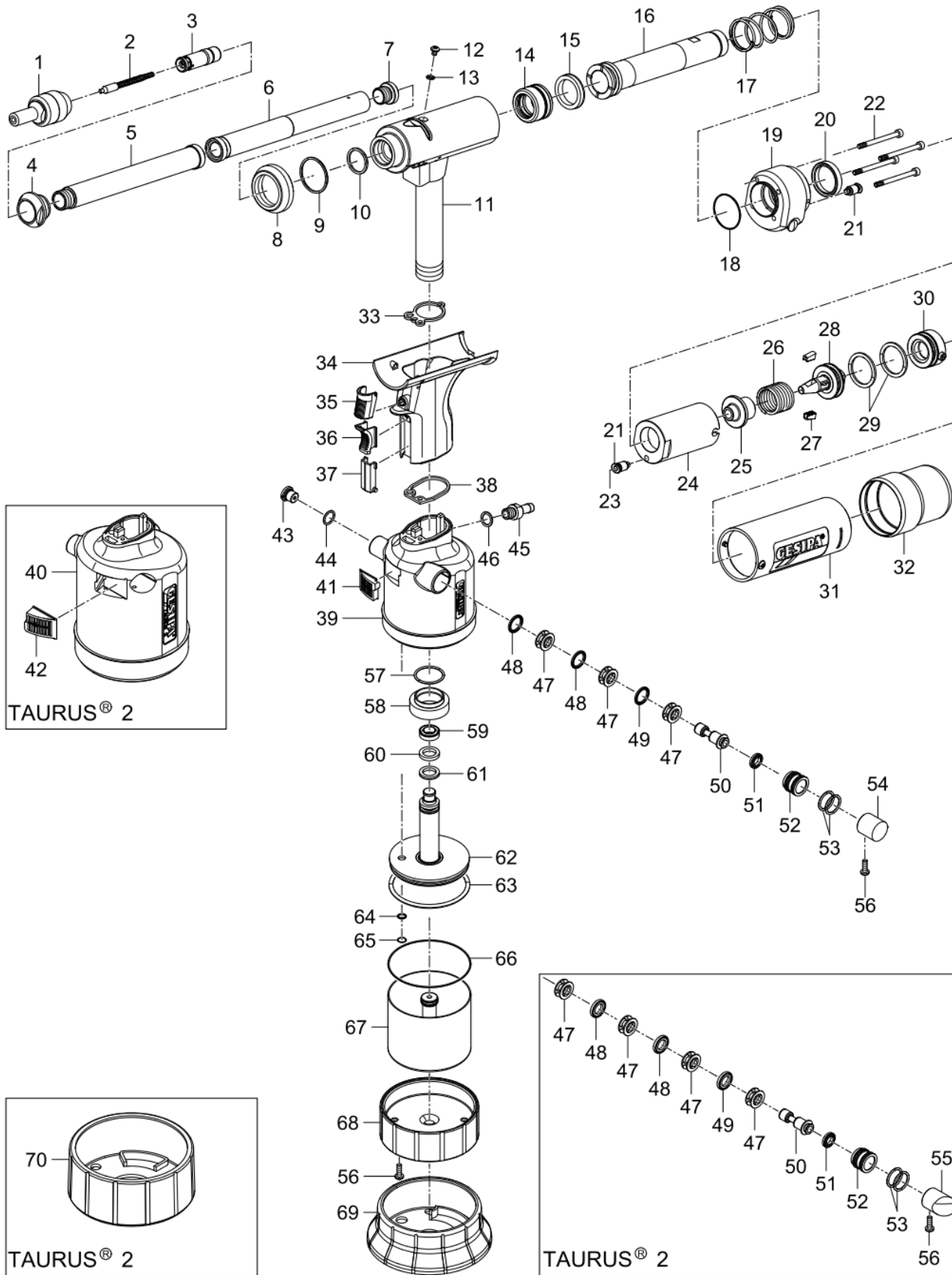

Hydro-pneumatic blind rivet setting tools

TAURUS® 1 Speed Rivet / TAURUS® 2 Speed Rivet

Spare part no.	TAURUS®-Type	Article no.	Designation
		145 7753	Spreader nosepiece 3.2, complete
		145 7754	Spreader nosepiece 4.0 complete
		145 7755	Spreader nosepiece 4.8 complete
		145 7756	Spreader nosepiece 3.2 extended, complete
		145 7757	Spreader nosepiece 4.0 extended, complete
		145 7758	Spreader nosepiece 4.8 extended, complete
1 •		145 0906	Spreader nosepiece 3.2 with opening mechanism complete
		145 0907	Spreader nosepiece 4.0 with opening mechanism complete
		145 0908	Spreader nosepiece 4.8 with opening mechanism complete
		145 0909	Spreader nosepiece 3.2 extended with opening mechanism, complete
		145 0910	Spreader nosepiece 4.0 extended with opening mechanism complete
		145 0911	Spreader nosepiece 4.8 extended with opening mechanism, complete
2 •		145 7759	Spring 3.2, complete
		145 7761	Spring 4.0 complete
		145 7763	Spring 4.8 complete
		145 7760	Spring 3.2 extended, complete
		145 7762	Spring 4.0 extended, complete
		145 7764	Spring 4.8 extended, complete
3 •		145 0918	Slide lock, complete
4		143 5705	Locator for guide tube SR
5 •		143 5710	Guide tube 2 SR
6 •		143 5709	Guide tube 1 SR
7		143 5712	End screw SR
8		143 5952	Ring
9		143 4266	O-ring
10		143 4462	O-ring
11	T1	145 0919	Tool head 1 SR, assembled
	T2	145 0937	Tool head 2 SR, assembled
12		144 6013	Oil screw plug
13		143 5612	Sealing ring M4
14 •		145 7765	Oil piston, complete
15 •		143 5723	Piston seal
16		143 5722	Pull tube SR
17		143 5721	Spring
18		144 6053	O-ring
19		143 5694	Connection block
20 •		144 6051	Rod seal
21		144 6049	Screw connection
22		144 5970	Allen screw
23		144 6045	Compressed air hose
24		143 5702	Clamp housing
25		143 5704	Pressure sleeve
26		143 5699	Compression spring
27 •		143 5701	Jaw
28		145 7766	Jaw guide, complete
29 •		144 6052	O-ring
30		145 0920	Cover, complete
31		145 0921	Protective tube, complete
32		143 5714	Protective cap

Spare part no.	TAURUS®-Type	Article no.	Designation
33 •		143 5472	Flat gasket 1
34		145 0922	Grip, complete
35		144 6025	Activation button
36		143 5642	Slider
37		143 6169	Orifice
38 •		143 5480	Flat gasket 2
39	T1	145 0923	Air cylinder SR 1, complete
40	T2	145 0938	Air cylinder SR 2, complete
41	T1	151 5051	Silencer 1
42	T2	144 6088	Silencer 2
43		145 7750	Pressure relief valve, complete
44		143 5484	O-ring
45		143 5667	Connecting nipple
46		144 6030	Sealing ring
47		143 5648	Spacer cage
48		143 5647	Rod seal
49		143 6248	Washer
50		143 6187	Rod seal
51		143 5675	Piston seal
52		143 5652	Piston housing
53		143 5688	O-ring
54		144 6026	Stopper 1
55	T2	144 6073	Stopper 2
56		144 5773	Housing screw short
57		143 5486	O-ring
58		143 5492	Al nut
59 •	T1	143 5658	Piston seal
	T2	143 5841	Piston seal
60 •	T1	143 5657	Guide ring 1
	T2	143 5825	Guide ring 2
61 •	T1	143 5656	Piston seal
	T2	143 5670	Piston seal
62	T1	145 7751	Air piston 1, complete
	T2	145 7860	Air piston 2, complete
63 •	T1	143 5660	O-ring
	T2	143 5834	O-ring
64	T1	143 5659	Rod seal
	T2	143 5635	Rod seal
65	T1	144 6027	Snap ring
	T2	144 6082	V-profile ring
66	T1	143 5680	O-ring
	T2	143 5839	O-ring
67	T1	145 7752	Cylinder 1, complete
	T2	145 7861	Cylinder 2, complete
68	T1	143 5508	Bottom 1
	T2	143 5761	Bottom 2
69	T1	143 6394	Rubber foot 1
70	T2	143 6371	Rubber foot 2
		144 5294	Hydraulic oil refill bottle, 100 ml

• Wearing parts

Hydro-pneumatic blind rivet setting tools

TAURUS® 1 Speed Rivet Axial eco TAURUS® 2 Speed Rivet Axial eco

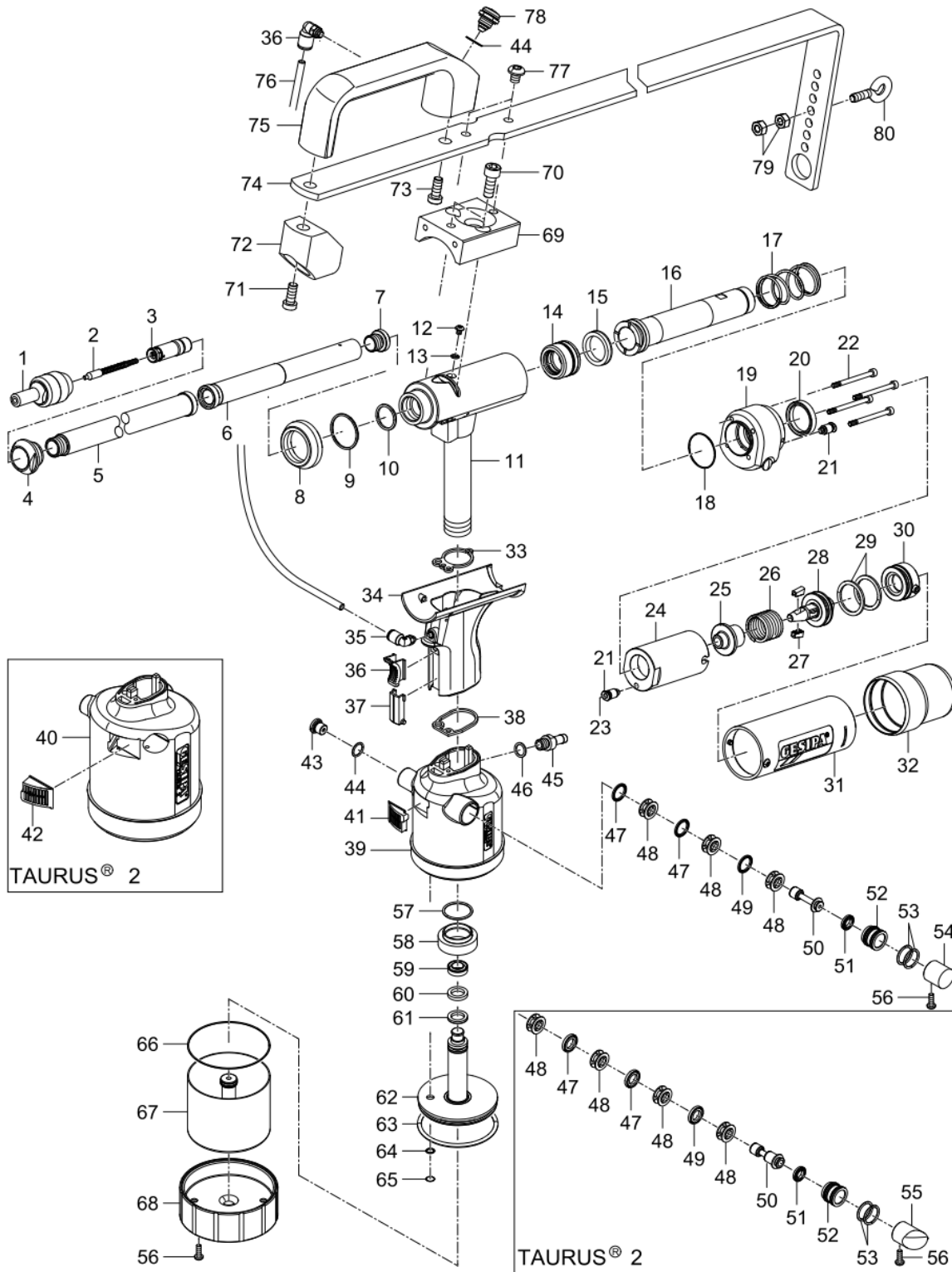

Hydro-pneumatic blind rivet setting tools

TAURUS® 1 Speed Rivet Axial eco TAURUS® 2 Speed Rivet Axial eco

Spare part no.	TAURUS®- Type	Article no.	Designation
		145 7753	Spreader nosepiece 3.2. complete
		145 7754	Spreader nosepiece 4.0. complete
		145 7755	Spreader nosepiece 4.8. complete
		145 7756	Spreader nosepiece 3.2. extended complete
		145 7757	Spreader nosepiece 4.0 extended complete
		145 7758	Spreader nosepiece 4.8 extended complete
		145 0906	Spreader nosepiece 3.2 with opening mechanism complete
1 •		145 0907	Spreader nosepiece 4.0 with opening mechanism complete
		145 0908	Spreader nosepiece 4.8 with opening mechanism complete
		145 0909	Spreader nosepiece 3.2 extended with opening mechanism, complete
		145 0910	Spreader nosepiece 4.0 extended with opening mechanism, complete
		145 0911	Spreader nosepiece 4.8 extended with opening mechanism, complete
		145 7759	Spring 3.2, complete
		145 7761	Spring 4.0, complete
		145 7763	Spring 4.8, complete
2 •		145 7760	Spring 3.2 extended, complete
		145 7762	Spring 4.0 extended, complete
		145 7764	Spring 4.8 extended, complete
3 •		145 0918	Slide lock, complete
4		143 5705	Locator for guide tube SR
5 •		143 5710	Guide tube 2 SR
		143 5685	Guide tube long 2 SR
6 •		143 5709	Guide tube 1 SR
7		143 5712	End screw SR
8		143 5952	Ring
9		143 4266	O-ring
10		143 4462	O-ring
11	T1	145 0924	Tool head, assembled 1 SR
	T2	145 0940	Tool head, assembled 2 SR
12		144 6013	Oil screw plug
13		143 5612	Sealing ring M4
14 •		145 7765	Oil piston, complete
15 •		143 5723	Piston seal
16		143 5722	Pull tube SR
17		143 5721	Spring
18		144 6053	O-ring
19		146 4433	Connection block
20 •		144 6051	Rod seal
21		144 6049	Screw connection
22		144 5970	Allen screw
23		143 5702	Clamp housing
24		143 5704	Pressure sleeve
25		143 5699	Compression spring
26		143 5701	Jaw
27		145 7766	Jaw guide, complete
28 •		144 6052	O-ring
29		145 0920	Cover, complete
30		145 0921	Protective tube, complete
31		143 5714	Protective cap
32 •		143 5472	Flat gasket 1
33		143 5638	Grip, complete
34		144 6230	Hose connector
35		143 5642	Slider
36		143 6169	Orifice
37 •		143 5480	Flat gasket 2

Spare part no.	TAURUS®- Type	Article no.	Designation
38	T1	145 0923	Air cylinder SR 1, complete
39	T2	145 0938	Air cylinder SR 2, complete
40	T1	151 5051	Silencer 1
41	T2	144 6088	Silencer 2
42		145 7750	Pressure relief valve, complete
43		143 5484	O-ring
44		143 5667	Connecting nipple
45		144 6030	Sealing ring
46		143 5648	Spacer cage
47		143 5647	Rod seal
48		143 6248	Washer
49		143 6187	Rod seal
50 •		143 5675	Piston seal
51		143 5652	Piston housing
52		143 5688	O-ring
53		144 6026	Stopper 1
54		144 6073	Stopper 2
55		144 5773	Housing screw, short
56		143 5486	O-ring
57		143 5492	Al nut
58 •	T1	143 5658	Piston seal
	T2	143 5841	Piston seal
59 •	T1	143 5657	Guide ring 1
	T2	143 5825	Guide ring 2
60 •	T1	143 5656	Piston seal
	T2	143 5670	Piston seal
61	T1	145 7751	Air piston 1, complete
	T2	145 7860	Air piston 2, complete
62 •	T1	143 5660	O-ring
	T2	143 5834	O-ring
63	T1	143 5659	Rod seal
	T2	143 5635	Rod seal
64	T1	144 6027	Snap ring
	T2	144 6082	V-ring
65	T1	143 5680	O-ring
	T2	143 5839	O-ring
66	T1	145 7752	Cylinder 1, complete
	T2	145 7861	Cylinder 2, complete
67	T1	143 5508	Bottom 1
	T2	143 5761	Bottom 2
68		144 6045	Compressed air hose*
69		143 5538	Holder
70		144 5630	Allen screw
71		144 6085	Allen screw
72		143 5684	Holder
73		144 6042	Allen screw
74		143 5682	Hanger
		143 5683	Hanger long
75		143 5575	Grip
76		144 6134	Hose
77		144 6087	Fillister head screw
78		145 6753	Valve complete
79		144 5262	Nut
80		144 5342	Screw
		144 5294	Hydraulic oil refill bottle, 100 ml

• Wearing parts

* The length required must always be specified on the order; the article numbers always refers to the price per metre.

Hydro-pneumatic blind rivet setting tools

PH 1 and PH 2

Spare part no.	Type	Article no.	Designation
1 •	PH 1	143 4285	Nosepiece 16/18
	PH 1, PH 2	143 4288	Nosepiece 16/24
	PH 1, PH 2	143 4289	Nosepiece 16/27
	PH 1, PH 2	143 4290	Nosepiece 16/29
	PH 2	143 4291	Nosepiece 16/32
	PH 2	143 4292	Nosepiece 16/36
2		143 4105	Steel head sleeve
3 •	PH 1	143 4243	Jaw housing
	PH 2	143 4102	Jaw housing
4 •	PH 1	143 4071	Jaws (2-part)
	PH 1	143 4241	Jaws (2-part) per pair with fine toothing for blind rivets with small nominal Ø (2.4; 3 and 3.2 all materials)
	PH 2	143 4103	Jaws (3-part)
5 •	PH 1	143 4242	Jaw pusher
	PH 2	143 4319	Jaw pusher
6 •		144 5314	Compression spring
7		143 4320	Jaw adapter
8		143 4321	Nut
9 •		143 4318	Piston guide with wiper
10 •		143 4323	K seal
11		143 4315	Tool head
12		144 5305	Snap ring
13 •		143 4324	K seal
14		143 4322	Piston
15 •		143 4326	K seal
16		143 4325	Sealing ring holder
17		145 6792	Tool head assembly (9-16)
18 •		144 5304	Return spring
19		143 4327	Closure screw
20		144 5302	Spent mandrel container
21		143 4343	Plastic grip
22		143 4337	Locking nut

Spare part no.	Type	Article no.	Designation
23	PH 1	143 4244	Tool body
	PH 2	143 4328	Tool body
24	PH 1	143 4246	Buffer ring
	PH 2	143 4334	Buffer ring
25	PH 1	145 6769	Air piston, complete
	PH 2	145 6791	Air piston, complete
26 •		143 4332	Round cord packing ring
27	PH 1	143 4245	End cap complete
	PH 2	143 4331	End cap complete
28		143 4330	Release lever
29		144 5307	Grooved pin
30		144 5308	Compression spring
31		145 6785	Valve tube
32		144 5306	Valve spring
33 •		143 4329	Valve spud
34 •		144 5303	Compression spring
35		143 5258	Sealing ring
36		145 6784	Hose fitting with sealing ring
		143 5261	Jaw pusher with reducing tube for thin mandrels Ø up to 2.3 mm
		143 5262	Jaw pusher with reducing tube for thin mandrels Ø up to 2.3 mm
		145 6780	Hydraulic oil (1 bottle) 250 ml
		143 4311	Universal wrench MSU

• Wearing parts

You will find detailed nosepiece allocation tables on page 353.

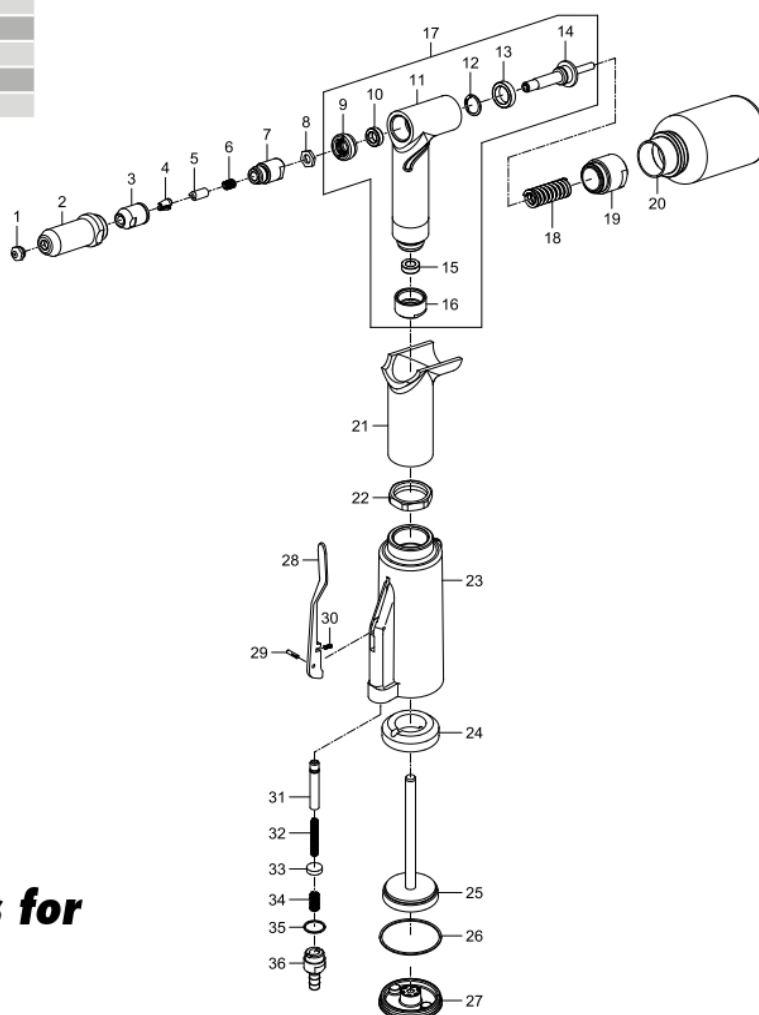

You will find spare part kits for PH 1 and PH 2 on page 387.

Hydro-pneumatic blind rivet setting tools

PH 1-L – tool no longer available

Spare part no.	Article no.	Designation
1	143 4247	Tool head
2	143 4249	Head
3	143 4250	Jaw housing
4	143 4251	Piston
105 •	143 4263	Jaw pusher
106	143 4264	Nozzle tube
107	143 4268	Closure screw
8 A	143 4262	Connector
109	143 4265	Tool body
10	143 4252	Sealing ring holder
13 •	143 4241	Jaws (2-part)
114 A •	143 4055	Nosepiece 10/18
114 B •	143 4061	Nosepiece 10/24
114 C •	143 4062	Nosepiece 10/27
15	145 6786	Piston guide with wiper
16 •	143 4342	Rod seal
117 •	143 4607	O-ring
18 •	143 4253	O-ring
19 •	143 4254	O-ring
20 •	143 4255	O-ring
121 •	143 4266	O-ring
22 •	143 4257	O-ring
23 •	143 4230	O-ring
24 •	143 4258	O-ring
125	143 4267	Valve body
126	144 5301	Valve screw

Spare part no.	Article no.	Designation
28	144 5260	Compression spring
30	144 5300	Snap ring
132	145 6770	Plastic tube
133	143 5248	Connecting nipple
134 •	143 5258	Sealing ring
35 •	144 5303	Compression spring
36 •	143 4324	K seal
37	144 5305	Snap ring
38 •	143 4326	K seal
139	144 5304	Return spring
40	143 4329	Valve spud
41	145 6785	Valve tube
42	144 5306	Valve spring
43	143 4259	Release lever
44	144 5307	Grooved pin
45	144 5308	Compression spring
46	143 4260	End cap complete PH 1
47 •	143 4332	Round cord packing ring
48	143 4246	Buffer ring
49	143 4261	Locking nut
50	145 6769	Air piston, complete
51	143 4343	Plastic grip
52 A	143 5032	Spent mandrel container, complete
	145 6780	Hydraulic oil (1 bottle) 250 ml

• Wearing parts

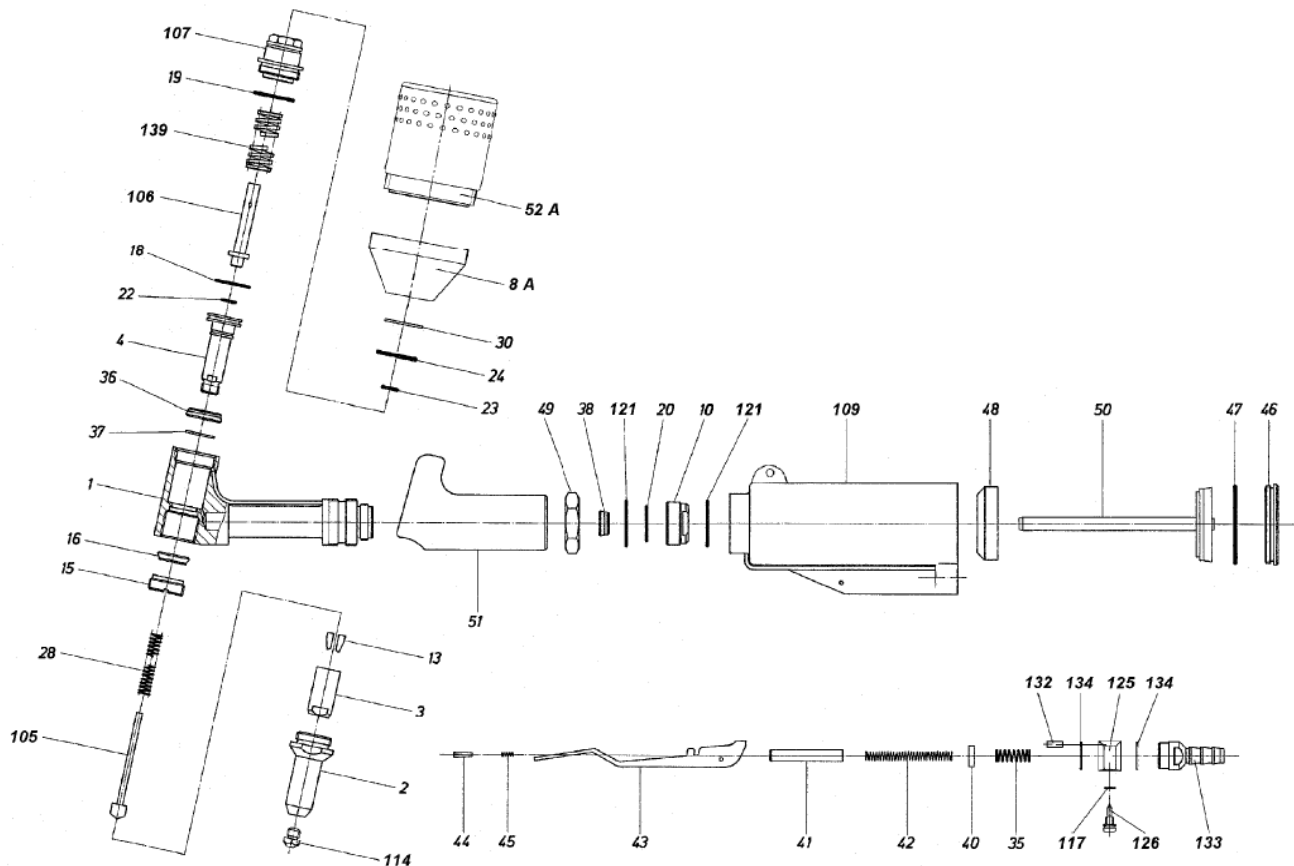

Hydro-pneumatic blind rivet setting tools

PH 2-KA – tool no longer available

Spare part no.	Article no.	Designation
101/81	143 4315	Tool head
2	145 6793	Valve tube
102	143 4105	Steel cores
3	145 6794	Valve support
4	145 6795	Spacer
104/81 •	143 4318	Piston guide with wiper
5	145 6796	Valve spud
106 •	143 4103	Jaws (3-part)
107 •	143 4319	Jaw pusher
8	145 6797	Control cylinder
108 •	144 5303	Compression spring
109 •	143 4102	Jaw housing
10	149 7539	Compression spring
110	143 4320	Jaw adapter
11	143 4348	O-ring
111	143 4321	Nut
12	145 6798	Plastic tube
112/81	143 4322	Piston
113/81 •	143 4323	K seal
114/81 •	143 4324	K seal
15	149 7540	Tube
115 •	144 5304	Return spring
16/24 •	143 4288	Nosepiece
16/27 •	143 4289	Nosepiece
16/29 •	143 4290	Nosepiece
16/32 •	143 4291	Nosepiece

Spare part no.	Article no.	Designation
16/36 •	143 4292	Nosepiece
117/81	144 5305	Snap ring
118/81	143 4325	Sealing ring holder
119/81 •	143 4326	K seal
120	143 4327	Closure screw
125-A	145 6799	Tool body
126	145 6784	Hose fitting
126 a	143 5258	Sealing ring
129	144 5306	Valve spring
131	144 5307	Grooved pin
133	143 4331	End cap complete
134 •	143 4332	Round cord packing ring
142	143 4334	Buffer ring
143 •	144 5314	Compression spring
144	143 4337	Locking nut
161	145 6791	Air piston, complete
162-B	145 7541	Grip
165	145 6792	Tool head assembly (101/81, 104/81, 112/81, 113/81, 114/81, 117/81, 118/81, 119/81)
170	143 5262	Reducing tube (PH 2)
172	144 5302	Spent mandrel container
176	143 4311	Special wrench MSU
825	145 6753	Release valve, complete
	145 6780	Hydraulic oil refill bottle 250 ml

• Wearing parts

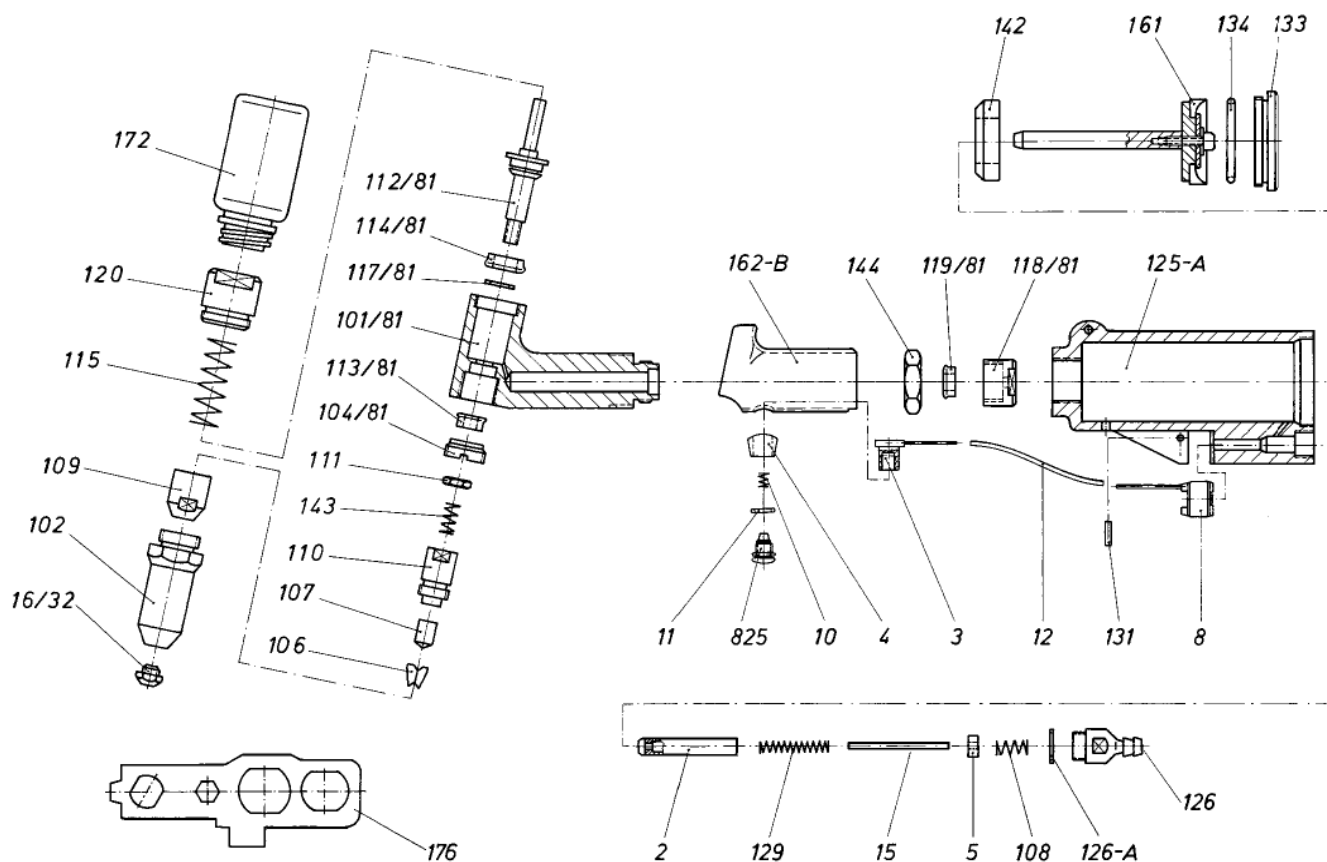

Hydro-pneumatic blind rivet setting tools

PH 1-VK* and PH 2-VK – *tool no longer available

Spare part no.	Article no.	Designation
1	143 4335	Tool head
2	143 4336	Pull piston
3 a	143 4349	Resetting piston
4	143 4338	Head
5	145 6786	Piston guide with wiper
6 a	143 4350	Closure screw
8 a •	143 4351	Jaw pusher
9	145 6788	Connection ring with hose adapter
10	145 6789	Spent mandrel container
13 •	143 4071	Jaws (2-part)
14 A •	143 4055	Nosepiece 10/18
14 B •	143 4061	Nosepiece 10/24
14 C •	143 4062	Nosepiece 10/27
17 •	143 4354	K seal
18	144 5305	Snap ring
19 •	143 4339	Compression spring
21 •	143 4341	Wiper
22 •	143 4342	Rod seal
23 •	143 4229	O-ring
26	144 5309	Cap closure
29	143 4325	Sealing ring holder
30 •	143 4326	K seal
31	143 4244	Tool body
310	143 4328	Tool body
32	143 4329	Valve spud

Spare part no.	Article no.	Designation
33	145 6785	Valve tube
34	144 5306	Valve spring
35	143 4330	Release lever
36	144 5307	Grooved pin
37	144 5308	Compression spring
38	143 4245	End cap
380	143 4331	End cap
39 •	143 4332	Round cord packing ring
40	143 4246	Buffer ring
400	143 4334	Buffer ring
41 •	144 5303	Compression spring
42	143 4337	Locking nut
43	145 6769	Air piston, complete
430	145 6791	Air piston, complete
44	143 5260	Plastic grip
45	143 5248	Connecting nipple
46	143 5250	Plastic tube
47	143 5255	Valve body
49	144 5310	Stud bolt
50	143 5258	Sealing ring
51	143 4230	O-ring
	145 6780	Hydraulic oil refill bottle 250 ml

• Wearing parts

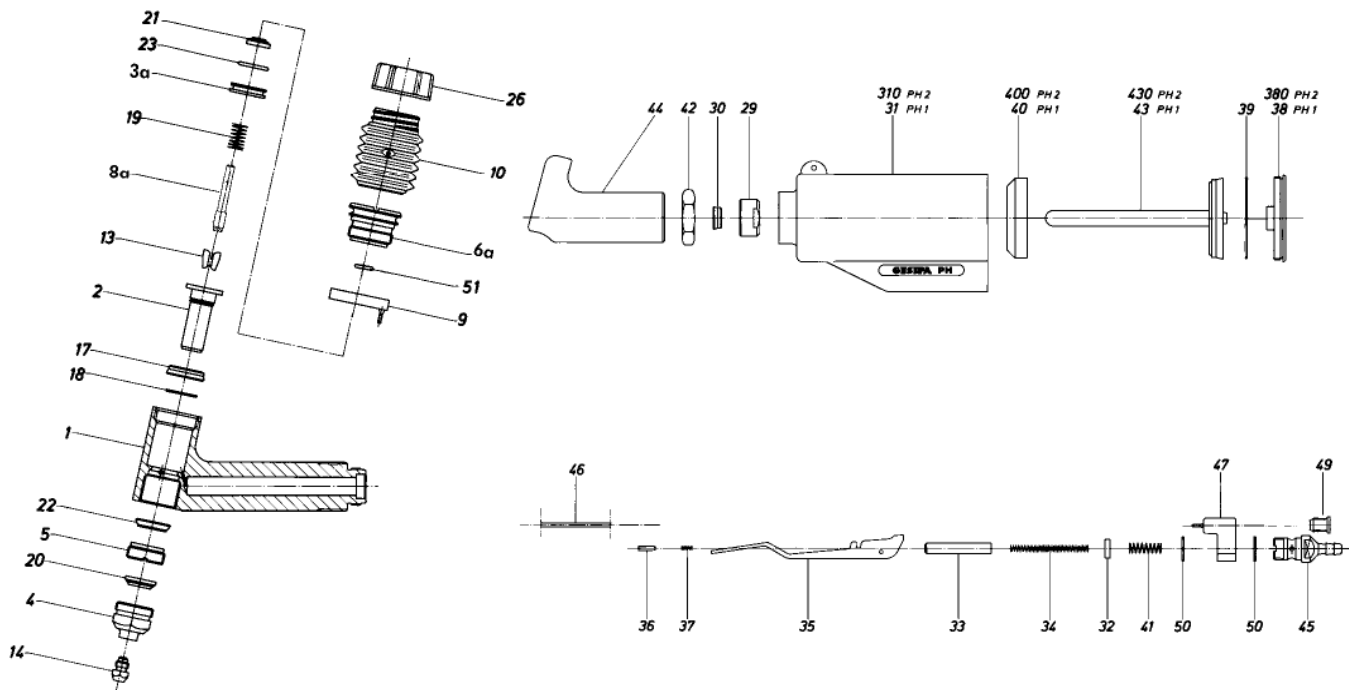

Hydro-pneumatic blind rivet setting tools

PH Axial

Spare part no.	Article no.	Designation
1	143 6115	Tool head
2	143 6117	Tool body
5	145 8066	Piston guide with wiper no. 69
	143 6114	Temporary attachment for part no. 5
6	143 6118	Damping ring
7	143 6119	Sealing ring mount
11	143 6123	Connection screw
12	143 6124	Guide tube
13	143 6125	Draw bar
14	143 6126	Release lever
16/24 •	143 4288	Nosepiece
16/27 •	143 4289	Nosepiece
16/29 •	143 4290	Nosepiece
16/32 •	143 4291	Nosepiece
16/36 •	143 4292	Nosepiece
20	143 4105	Head
22 •	143 4103	Jaws (3-part)
25 •	143 4319	Jaw pusher
26 •	143 4102	Jaw housing
27	143 4320	Jaw adapter
28	143 4322	Piston
29	145 6785	Valve tube
31	144 6166	Connection plug
35	144 5700	Cylinder screw (together)
36	143 5257	Valve screw
37	143 6132	Eye bolt with assembly mandrel
39	143 4321	Nut
40	144 5307	Grooved pin
42	144 6167	Snap ring
43	144 5305	Snap ring
46	144 6168	Supporting washer
47	143 6133	Compression spring
48 •	144 5304	Return spring
49	144 5306	Valve spring
50	144 5308	Compression spring

Spare part no.	Article no.	Designation
51 •	144 5314	Compression spring
54	143 6135	O-ring
55	143 6134	O-ring
56	143 6136	O-ring
58	143 4497	O-ring
59	143 6137	O-ring
60	143 6116	Rod seal
61	143 5256	O-ring
63	143 6138	O-ring
64 •	143 4323	K seal
65 •	143 4324	K seal
66 •	143 4326	K seal
69	143 6139	Wiper
70	144 6169	Sealing ring
71 •	143 4329	Valve spud
72	143 6140	USIT ring
74	145 8068	Union with O-ring no. 63
75 *	143 6141	Adapter
76 *	144 6164	Spent mandrel container
76 a	143 6142	Impact washer
77 *	144 5265	Suspension bracket
78	143 6143	Drain hose (1.5 m long)
79	144 5819	Stud bolt
80	145 8070	Air piston complete with no. 55 and 60
85	145 8071	End cap complete
90	145 8072	Screw-in nozzle, complete
95	145 8073	Hydraulic seal kit with part no. 54, 56, 58, 64, 65, 66
100	145 8074	Pneumatic seal kit for air piston no. 80 with part no. 54, 55, 60
125 •	143 6130	Jaw pusher with reducing tube for blind rivets up to 4 mm Ø and Al and Cu
	145 6780	Hydraulic oil refill bottle 250 ml

- Wearing parts
- * Special accessories

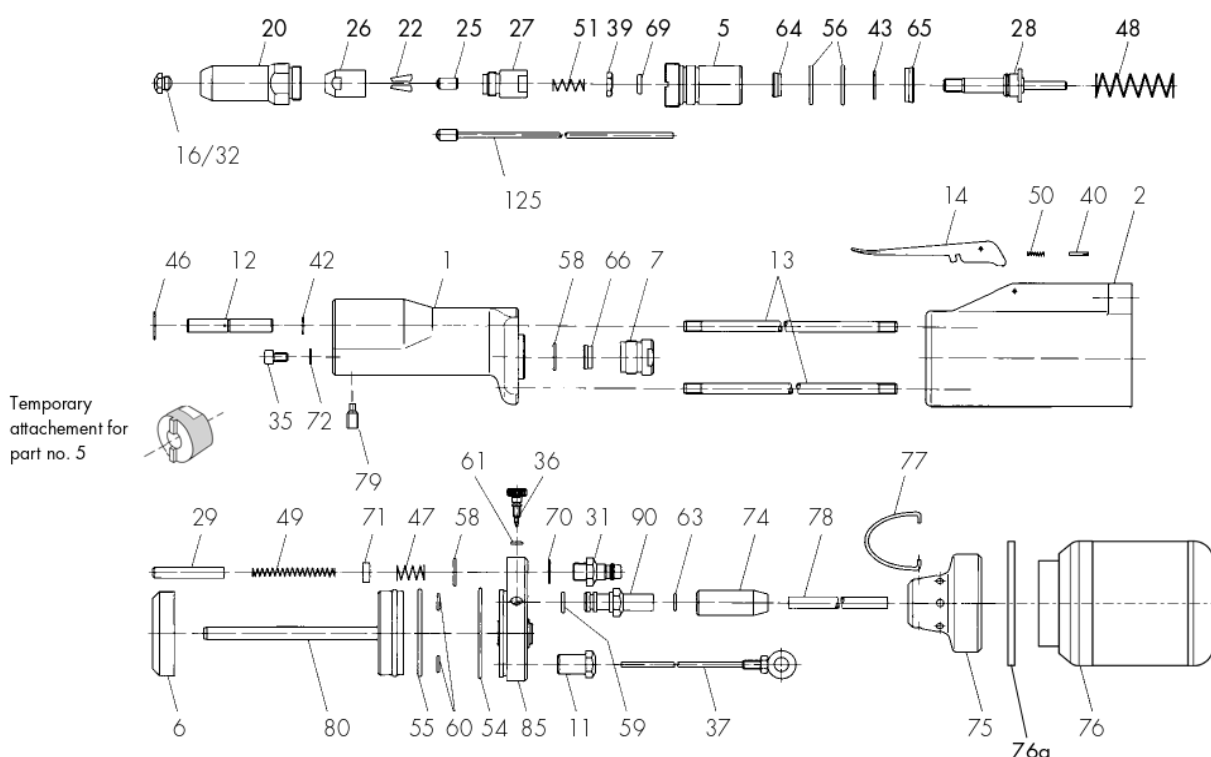

Hydro-pneumatic blind rivet setting tools

PH 2000 / PH 2000-BT (only for BULB-TITE®)

Spare part no.	Article no.	Designation
1 •	143 4288	Nosepiece 16/24
	143 4289	Nosepiece 16/27
	143 4290	Nosepiece 16/29
	143 4291	Nosepiece 16/32
	143 4292	Nosepiece 16/36
	143 4293	Nosepiece 16/40
	143 4300	Nosepiece 16/45
2	143 4105	Steel head sleeve
3 •	143 4129	Jaw housing
4 •	143 4103	Jaws (3-part)
5	145 6735	Jaw pusher up to 4 mm Ø blind rivets
	143 4167	Jaw pusher up to 4,8 mm Ø blind rivets
	143 4168	Jaw pusher up to 6,4 mm Ø blind rivets
6	143 4232	Hand protection
7	145 6741	Tool head complete
8 •	145 6754	Replenishing screw complete
9	144 5265	Suspension bracket
10 •	145 6749	Annular piston complete
11 •	145 6750	Scraper ring complete

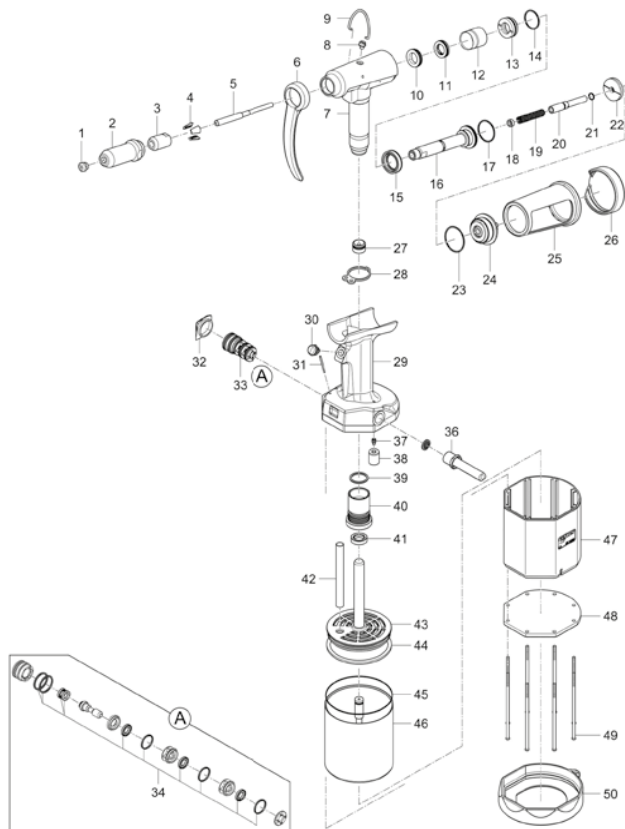

Spare part no.	Article no.	Designation
12 •	145 6751	Cylinder sleeve complete
13 •	145 6752	Casing ring complete
14 •	143 4227	O-ring
15 •	145 6757	Groove ring with supporting ring
16	145 6745	Lock activator complete
17 •	143 4226	O-ring
18 •	143 4210	Spacer ring
19 •	144 5290	Compression spring
20 •	143 4211	Pressure pipe complete
21 •	143 4231	O-ring
22	143 4212	Resetting piston, complete
23 •	143 4225	O-ring
24	143 4213	Cover complete
25	143 4233	Spent mandrel container, complete
26	144 5295	Air deflector
27	143 4214	Valve body complete
28 •	143 4221	Flat gasket
29	145 6742	Grip, complete
30	145 6753	Release valve, complete
31	143 4219	Bolt
32	143 4216	Silencer
33	145 6756	Distributing valve complete
34 •	145 6758	Set of seals for slide valve
36	143 4220	Hose complete
37	144 5819	Stud bolt
38	143 4218	Suction valve complete
39 •	143 4228	O-ring
40	145 6755	Sealing ring mount complete
41 •	143 4223	Rod seal
42	143 4217	Channel tube
43	145 6748	Air piston complete
44 •	143 5201	O-ring
45 •	143 4224	O-ring
46	145 6743	Cylinder complete
47	145 6760	Casing
48	143 4236	Bottom
49	144 5292	Countersunk screw
50 •	143 4237	Rubber base
	144 5293	Ball Allen key
	143 4311	Universal wrench MSU
	144 5294	Hydraulic oil refill bottle, 100 ml
	143 4234	Jaw assembly conversion kit for small rivet Ø
	145 6759	Changeover set for BULB-TITE®
•	143 4301	Nosepiece 16/26 BT for 4 mm Ø BULB-TITE® rivets
•	143 4302	Nosepiece 16/32 BT for 5,2 mm Ø BULB-TITE® rivets
•	143 4303	Nosepiece 16/42 BT for 6,3 mm Ø BULB-TITE® rivets
•	143 4304	Nosepiece 16/48 BT for 7,7 mm Ø BULB-TITE® rivets
	143 4167	Jaw pusher 4,0 and 5,2 mm Ø blind rivets
	143 4168	Jaw pusher 6,3 and 7,7 mm Ø blind rivets
•	143 4173	Jaws (3-part) for BULB-TITE® rivets
	145 6762	Changeover set for MEGA GRIP®
•	143 4380	Nosepiece 16/31 MG
•	143 4381	Nosepiece 16/41 MG
•	143 4240	Jaws (3-part) for MEGA GRIP® rivets
	143 4168	Jaw Pusher

• Wearing parts
You will find detailed nosepiece allocation tables on page 353.

You will find spare part kits for PH 2000 on page 387.

Special accessories for hydro-pneumatic setting tools

VAS for PH 1 and PH 2

Spare part no.	Article no.	Designation
19-A	143 5248	Connecting nipple
21-A	143 5249	Nozzle tube
22-A •	143 5250	Plastic tube
23-A	143 5251	Connection screw complete with 24-A and 30-A
24-A •	143 5252	O-ring set
25-A	143 5253	Connection ring complete with 31-A and nipple
26-A	143 5254	Slotted nut
27-A	143 5255	Valve body with hose adapter
28-A •	143 5256	O-ring
29-A	143 5257	Valve screw
30-A •	143 5259	Scraper ring set
31-A	144 5828	Locking screw
126-A •	143 5258	Sealing ring
162-A	143 5260	Plastic grip
890	143 4233	Spent mandrel container, complete
896	144 5295	Air deflector
70	143 5261	PH 1 jaw pusher with reducing tube for thin mandrels up to 2.3 mm Ø
71	143 4270	PH 1 jaw pusher with reducing tube for thin mandrels up to 3.2 mm Ø
170	143 5262	PH 2 jaw pusher with reducing tube for thin mandrels up to 2.3 mm Ø
176	143 4311	Universal wrench MSU

• Wearing parts

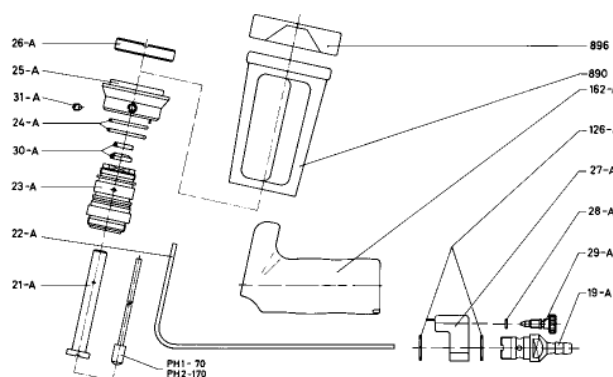

Angle head for PH 1 and PH 2

Spare part no.	Article no.	Designation
1	143 4031	Housing for 3-part jaws
2	143 4032	Knurled nut
3	143 4033	Locking nut
4 •	143 4034	Jaw housing for 3-part jaws
4A •	143 4037	Jaw housing for 2-part jaws
5	143 4035	Lock activator
6A •	143 4071	Jaws (2-part) per set
106 •	143 4103	Jaws (3-part) per set
7 •	144 5256	Jaw pusher for 3-part jaws
7A •	143 4038	Jaw pusher for 2-part jaws
8 •	144 5257	Compression spring
9	143 4036	Plug for 3-part jaws
9A	143 4039	Plug for 2-part jaws
16/18 •	143 4285	Nosepiece
16/24 •	143 4288	Nosepiece
16/27 •	143 4289	Nosepiece
16/29 •	143 4290	Nosepiece
16/32 •	143 4291	Nosepiece

• Wearing parts

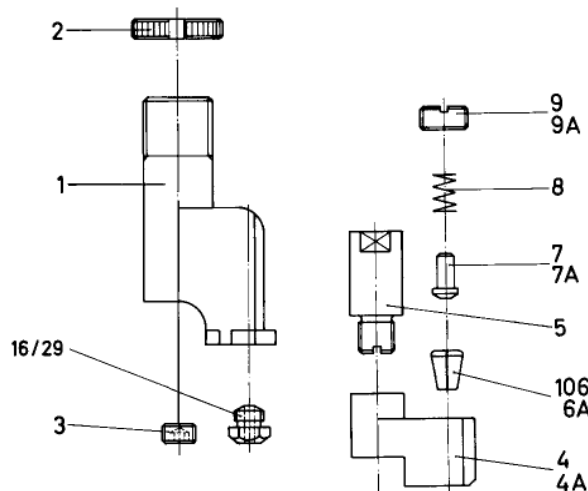

Special accessories for hydro-pneumatic setting tools

Small jaw assembly for PH 1 and PH 2

Spare part no.	Article no.	Designation
6 •	143 4071	Jaws (2-part) per set
7 •	143 4242	Jaw pusher
10/18 •	143 4055	Nosepiece
10/24 •	143 4061	Nosepiece
10/27 •	143 4062	Nosepiece
10/29 •	143 4064	Nosepiece
10/32 •	143 4065	Nosepiece
71	143 4270	PH 1 jaw pusher with reducing tube for 2.4 mm Ø Al and 3.2 mm Ø CAP® blind rivets
110 a	143 4345	Jaw adapter
143 •	144 5314	Compression spring
804 a	143 4346	Steel head sleeve
805 a •	143 4344	Jaw housing

• Wearing parts

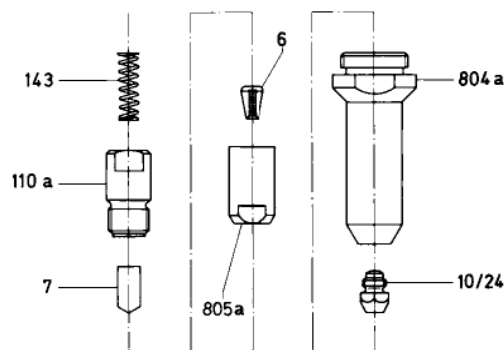

Small jaw assembly for PH 2000

Spare part no.	Article no.	Designation
6 •	143 4071	Jaws (2-part) per set
10/18 •	143 4055	Nosepiece
10/24 •	143 4061	Nosepiece
10/27 •	143 4062	Nosepiece
10/29 •	143 4064	Nosepiece
10/32 •	143 4065	Nosepiece
804 a	143 4346	Steel head sleeve
805 a •	143 4344	Jaw housing
8080 c •	143 4169	Jaw pusher with nozzle tube

• Wearing parts

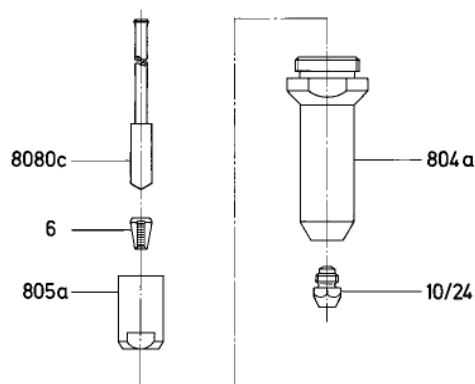

Special accessories for hydro-pneumatic setting tools

Small jaw assembly for PH-Axial

Spare part no.	Article no.	Designation
298	145 8075	Small jaw assembly complete with nosepiece 10/24 (optionally also with 10/18, 10/27, 10/29, 10/32)
6 •	143 4071	Jaws (2-part) per set
10/18 •	143 4055	Nosepiece
10/24 •	143 4061	Nosepiece
10/27 •	143 4062	Nosepiece
10/29 •	143 4064	Nosepiece
10/32 •	143 4065	Nosepiece
110 a	143 4345	Jaw adapter
143 •	144 5314	Compression spring
804 a	143 4346	Head
805 a •	143 4344	Jaw housing
130 •	143 6131	Jaw pusher with reducing tube for blind rivets up to 4 mm Ø and Al and Cu

• Wearing parts

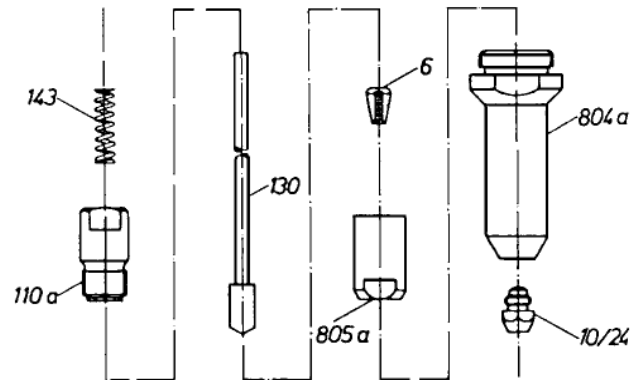

Spent mandrel container for PH-Axial

Spare part no.	Article no.	Designation
2	143 6120	Adapter
3	143 6121	Cover
4	143 6122	Stud bolt
7	143 6127	Container
8	143 6128	Casing
10	143 6129	Ring eye M6
14	144 6165	Allen screw
	145 8065	Spent mandrel container, complete for PH-Axial

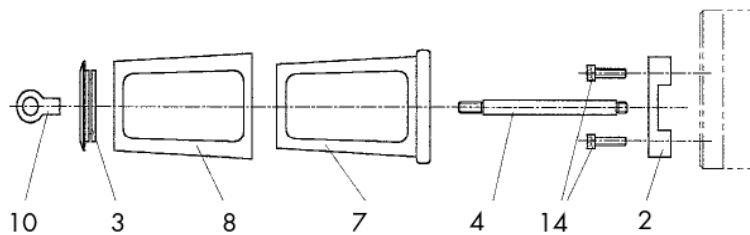

Special accessories for hydro-pneumatic setting tools

PH1/PH2 extension unit 100 mm

Two-part for PH 1 and PH 2:

Article no. 145 6779

Spare part no.	Article no.	Designation
1	143 4164	Extension sleeve
2	143 4166	Extension piece

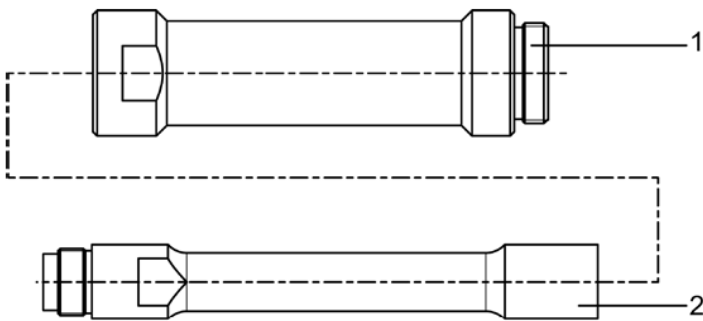

PH 2000 extension unit 100 mm

Three-part for PH 2000:

Article no. 145 6765

Spare part no.	Article no.	Designation
1	143 4164	Extension sleeve
2	143 4165	Extension piece
3	143 4170	Jaw pusher with nozzle tube

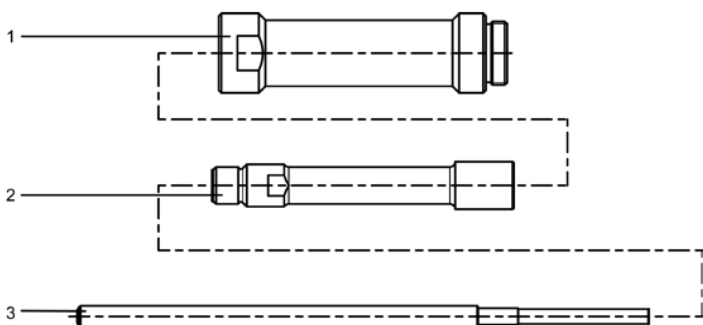

Nosepieces for blind rivet setting tools

NTS, NTX, NTX-F, Flipper®, SN 1, PH 1-VK, PH 2-VK and PH 1-L

Rivet Ø	Rivet material	Ø d	Ø D	Standard	Article no.	Extended version (9mm)	Article no.
2.4	Al	1.6	6.0	10/16	143 4054		
2.4	Al	1.8	6.0	10/18	143 4055	V-10/18	143 4096
3.2	CAP® Al, CAP® copper	1.8	6.0	10/18	143 4055	V-10/18	143 4096
3 and 3.2	Al, Cu, steel, stainless steel, Stinox, Al/Al, PG Al, PG steel	2.4	6.0	10/24	143 4061	V-10/24	143 4097
4	Al, Cu	2.4	6.0	10/24	143 4061	V-10/24	143 4097
4	Steel, CAP® Al, CAP® Cu, Al/Al, PG Al	2.7	6.0	10/27	143 4062	V-10/27	143 4098
4	Stainless steel, Stinox, PG steel	2.9	8.0	10/29	143 4064	V-10/29	143 4099
4.8	CAP® Al, CAP® Cu	2.9	8.0	10/29	143 4064	V-10/29	143 4099
4.8 and 5	Al, PG Al	3.2	8.0	10/32	143 4065	V-10/32	143 4100
4	Plastic	3.0		10/30 K	143 4092		
5	Plastic	3.5		10/35 K	143 4093		
6	Plastic	4.0		10/40 K	143 4094		

Standard version
10/..... Nosepieces

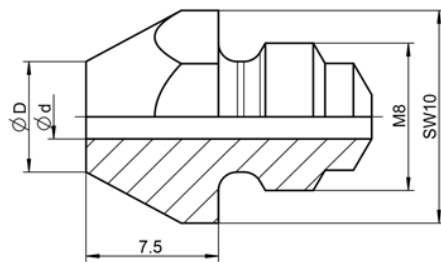

Extended version (9mm)
V-10/.....Nosepieces

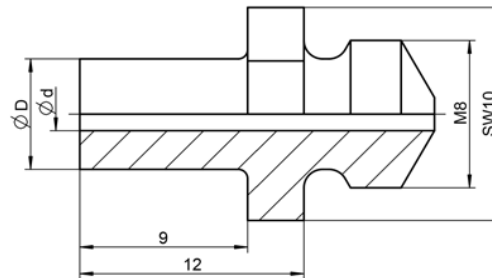

Nosepieces for blind rivet setting tools

SN 2*, HN 2, PH 1, PH 2, PH 2-KA, PH-Axial and PH 2000

Rivet Ø	Rivet material	Ø d	Ø D	Standard	Article no.	Extended version (10 mm)	Article no.
2.4	Al	1.8	6.0	16/18	143 4285	V-16/18	143 4370
3.2	CAP® Al, CAP® copper	1.8	6.0	16/18	143 4285	V-16/18	143 4370
3	Al/Cu	2.0	6.0	16/20	143 4287	V-16/20	143 4371
3 and 3.2	Al, Cu, steel, stainless steel, Stinox, Al/ Al, PG Al, PG steel	2.4	6.0	16/24	143 4288	V-16/24	143 4372
4	Al, Cu, CAP® Al, CAP® Cu	2.4	6.0	16/24	143 4288	V-16/24	143 4372
4	Steel, Al/ Al, PG Al	2.7	8.0	16/27	143 4289	V-16/27	143 4373
4	Stainless steel, Stinox, PG steel	3.0	8.0	16/29	143 4290	V-16/29	143 4374
4.8 and 5	CAP® Al, CAP® Cu, PG Al	3.0	8.0	16/29	143 4290	V-16/29	143 4374
4.8 and 5	Steel, Al/ Al	3.35	8.0	16/32	143 4291	V-16/32	143 4375
4.8 and 5	Stainless steel, Stinox, PG steel	3.6	10.0	16/36	143 4292	V-16/36	143 4376
6	Al	3.6	10.0	16/36	143 4292	V-16/36	143 4376
6	Steel	4.0	10.0	16/40	143 4293	***V-16/40	143 4369
6.4	Al, PG Al	4.0	10.0	16/40	143 4293	***V-16/40	143 4369
6.4	Steel, Al/ Al	4.5	10.0	16/45	143 4300	V-16/45	143 4378
4	Plastic	3.0	6.0	**16/30 K	143 4130		
5	Plastic	3.5	6.0	**16/35 K	143 4131		
6	Plastic	4.0	6.0	**16/40 K	143 4132		

* up to April 2010

Standard version
16/..... Nosepieces

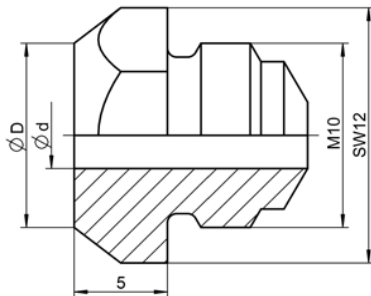

Extended version (10 mm)
V-16/..... Nosepieces

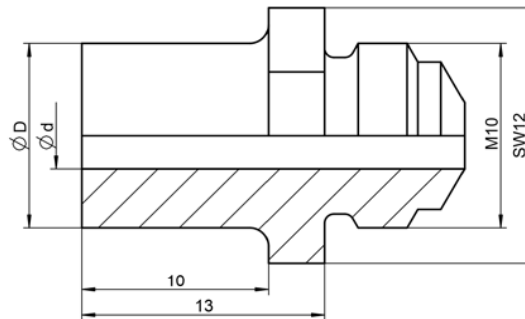

Rivet Ø	Rivet material	Ø d	Ø D	Designation	Article no.
4.8	all MEGA GRIP®	3.1	8.0	16/31 MG	143 4380
6.4	all MEGA GRIP®	4.2	10.0	16/41 MG	143 4381
4.8	Monobolt®	3.15	7.7	16/31 MB	143 4379
6.4	Monobolt®	4.2	9.5	16/42 MB	143 4163

Rivet Ø	Rivet material	Ø d	Ø D	Designation	Article no.
4	all BULB-TITE®	2.64	8.0	16/26 BT	143 4301
5.2	all BULB-TITE®	3.23	10.0	16/32 BT	143 4302
6.3	all BULB-TITE®	4.2	11.0	16/42 BT	143 4303
7.7	all BULB-TITE®	4.8	10.0	16/48 BT	143 4304

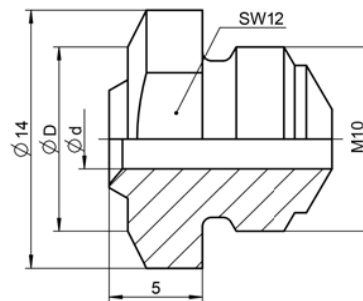
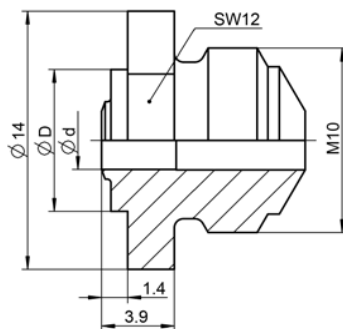

! The suitability of nosepiece and fastener needs to be tested by the user and is user's own responsibility!

Nosepieces for blind rivet setting tools

SN 2*, AccuBird®, AccuBird® Pro, PowerBird®, PowerBird® Pro Gold Edition und TAURUS®

Rivet Ø	Rivet material	Ø d	Ø D	Standard	Article no.	Extended version (8mm)	Article no.
2,4	Al	1.6	6.0	17/16	143 4972	-	-
2,4	Al	1.8	6.0	17/18	143 4976	V-17/18	143 4979
3.2	CAP® Al, CAP® copper	1.8	6.0	17/18	143 4976	V-17/18	143 4979
3	Al/Cu	2.0	6.0	17/20	143 4994	V-17/20	145 7315
3	Al, Cu, Steel, Stainless steel, Stinox, Al/Al	2.2	6.0	17/22	143 5018	V-17/22	145 7323
3 and 3.2	Al, Cu, Steel, Stainless steel, Stinox, Al/Al, PG Al, PG steel	2.4	6.0	17/24	143 4955	V-17/24	143 4980
4	Al, Cu, CAP® Al, CAP® Cu	2.4	6.0	17/24	143 4955	V-17/24	143 4980
4	Steel, Al/Al, PG Al	2.7	8.0	17/27	143 4973	V-17/27	143 4981
4	Stainless steel, Stinox, PG steel	3.0	8.0	17/29	143 4974	V-17/29	143 4982
4.8 and 5	Al, CAP® Al, CAP® Cu, PG Al	3.0	8.0	17/29	143 4974	V-17/29	143 4982
4.8 and 5	Steel, Al/Al	3.35	8.0	17/32	143 4975	V-17/32	143 4983
4.8 and 5	Stainless steel, Stinox, PG steel	3.6	10.0	17/36	143 4977	V-17/36	143 4984
6	Al	3.6	10.0	17/36	143 4977	V-17/36	143 4984
6	Steel	4.0	10.0	17/40	143 4999	V-17/40	143 5038
6.4	Al, PG Al	4.0	10.0	17/40	143 4999	V-17/40*	143 5038
6.4	Steel, Al/Al	4.5	10.0	17/45	143 4860	V-17/45**	143 4866

Rivet Ø	Rivet material	Ø d	Ø D	Designation	Article no.
4.8	all MEGA GRIP®	3.1	8.0	17/31 MG	143 4993
6.4	all MEGA GRIP®	4.2	10.0	17/41 MG	143 4865
4.8	Monobolt®	3.1	8.0	17/31 MB *	143 4868
6.4	Monobolt®	4.2	9.5	17/42 MB *	143 4869

Rivet Ø	Rivet material	Ø d	Ø D	Designation	Article no.
4	all BULB-TITE®	2.64	8.0	17/26 BT	143 4985
5.2	all BULB-TITE®	3.23	10.0	17/32 BT	143 4986
6.3	all BULB-TITE®	4.2	11.0	17/42 BT	143 4988
7.7	all BULB-TITE®	4.8	10.0	17/48 BT	143 4989

* from May 2010

Standard version
17/.....Nosepieces

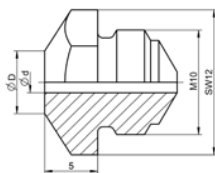

Extended version (8 mm)
V-17/.....Nosepieces

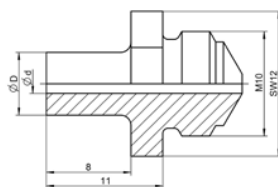

Special version
17/.....MG Nosepieces

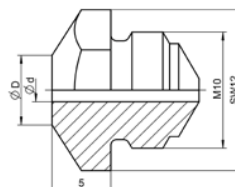

Special version
17/.....MB Nosepieces

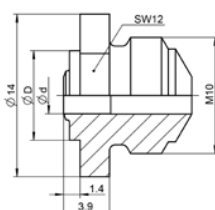

Special version
17/.....BT Nosepieces

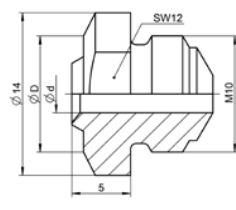

The suitability of nosepiece and fastener needs to be tested by the user and is user's own responsibility!

Special nosepieces for blind rivet setting tools

Retaining nosepieces

for AccuBird®, AccuBird® Pro, PowerBird® and PowerBird® Pro Gold Edition

Rivet Ø	Rivet material	Ø d	Designation	Article no.
2.4	Al	1.85	17/18 R	143 5010
3.2	CAP® Al, CAP® copper	1.85	17/18 R	143 5010
3	Al/Cu, Al, Cu, Steel, Stainless steel, Stinox, Al/Al	2.0	17/20 R	145 0669
3	Al, Cu, Steel, Stainless steel, Stinox, Al/Al	2.2	17/22 R	145 0670
3 and 3.2	Al, Cu, Steel, Stainless steel, Stinox, Al/Al, PG Al, PG steel	2.4	17/24 R	143 5011
4	Al, Cu, CAP® Al, CAP® Cu	2.4	17/24 R	143 5011
4	Steel, Al/Al, PG Al	2.7	17/27 R	143 5012
4	Stainless steel, Stinox, PG steel	2.9	17/29 R	143 5013
4.8 and 5	Al, CAP® Al, CAP® Cu, PG Al	2.9	17/29 R	143 5013
4.8 and 5	Steel, Al/Al	3.2	17/32 R*	143 5014
4.8 and 5	Stainless steel, Stinox, PG steel	3.6	17/36 R*	143 5015
6	Al	3.6	17/36 R*	143 5015
6	Steel	4.0	17/40 R**	145 7347
6.4	Al, PG Al	4.0	17/40 R**	145 7347
6.4	Steel, Al/Al	4.5	17/45 R**	145 7348

*Also for PowerBird®

**Only for PowerBird®

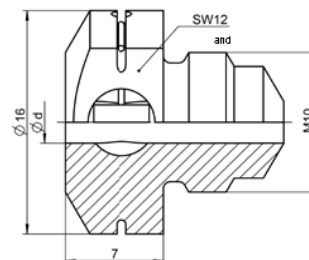

Universal nosepiece

Rotary star Rivet Ø	Allocation / working range Rivet material	Ø d	HN 2, SN 2, PH 1, PH 2, PH 2-KA and PH 2000	AccuBird®, AccuBird® Pro, PowerBird® and PowerBird® Pro Gold Edition
2.4	Al	1.8	Article no. 145 6776	Article no. 143 4960
3.2	CAP® Al, CAP® copper	1.8		
3 and 3.2	Al, Cu, Steel, Stainless steel, Stinox, Al/Al, PG Al, PG steel	2.4		
4	Al, Cu, CAP® Al, CAP® Cu	2.4		
4	Steel, Al/Al, PG Al	2.7		
4	Stainless steel, Stinox, PG steel	2.9		
4.8 and 5	Al, CAP® Al, CAP® Cu, PG Al	2.9		
4.8 and 5	Steel, Al/Al			

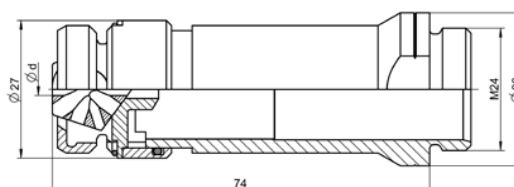

Special nosepieces for blind rivet setting tools

NTS, NTS-K, NTX, NTX-F, Flipper®, SN 1, PH 1-VK, PH 2-VK and PH 1-L

Rivet Ø	Rivet material	Ø d	Ø D	Designation	15 mm	20 mm	25 mm
3 and 3.2	Al, Cu, Steel, Stainless steel, Stinox, Al/Al, PG Al, PG steel	2.4	6.5	10/24 SL...	-	145 6630	145 6632
4	Al, Cu	2.4	6.5	10/24 SL...	-	145 6630	145 6632
4	Steel, CAP® Al, CAP® Cu, Al/Al, PG Al	2.7	7.0	10/27 SL...	145 6634	145 6635	-
4	Stainless steel, Stinox, PG steel	2.9	8.0	10/29 SL...	145 6638	-	-
4.8	CAP® Al, CAP® Cu	2.9	8.0	10/29 SL...	145 6638	-	-
4.8 and 5	Al, PG Al	3.2	8.0	10/32 SL...	145 6641	145 6642	-

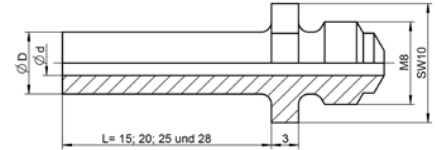

CAUTION! BLIND RIVETS MUST BE ORDERED AS A CUSTOM-MADE PRODUCT WITH EXTENDED MANDREL!

SN 2, HN 2, PH 1, PH 2, PH 2-KA, PH-Axial and PH 2000

Rivet Ø	Rivet material	Ø d	Ø D	Designation	15 mm	20 mm	25 mm	28 mm
3 and 3.2	Al, Cu, Steel, Stainless steel, Stinox, Al/Al, PG Al, PG steel	2.4	6.0	16/24 SL...	145 6812	145 6813	145 6814	145 6815
4	Al, Cu	2.4	6.0	16/24 SL...	145 6812	145 6813	145 6814	145 6815
4	Steel, PG Al	2.7	8.0	16/27 SL...	145 6816	145 6817	145 6818	145 6819
4	Stainless steel, Stinox, PG steel	3.0	8.0	16/29 SL...	145 6820	145 6821	145 6822	145 6823
4.8 and 5	Al, PG Al	3.0	8.0	16/29 SL...	145 6820	145 6821	145 6822	145 6823
4.8 and 5	Steel	3.35	8.0	16/32 SL...	145 6824	145 6825	145 6826	-
4.8 and 5	Stainless steel, Stinox, PG steel	3.6	10.0	16/36 SL...	145 6828	-	-	-
6	Al	3.6	10.0	16/36 SL...	145 6828	-	-	-
6.4	Al, PG Al	4.0	10.0	16/40 SL...	145 6807	-	-	-
6.4	Steel, Al/Al	4.5	10.0	16/45 SL...	145 6805	145 6806	-	-

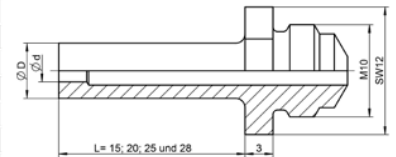

CAUTION! BLIND RIVETS MUST BE ORDERED AS A CUSTOM-MADE PRODUCT WITH EXTENDED MANDREL!

AccuBird®, AccuBird® Pro, PowerBird®, PowerBird® Pro Gold Edition and TAURUS®

Rivet Ø	Rivet material	Ø d	Ø D	Designation	15 mm	20 mm	25 mm	28 mm
2.4	Al	1.8	6.0	17/18 SL...	145 7367	145 7368	146 4039	146 4040
3.2	CAP® Al, CAP® copper	1.8	6.0	17/18 SL...	145 7367	145 7368	146 4039	146 4040
3	Al/Cu	2.0	6.0	17/20 SL...	145 7314	145 7305	146 4041	145 7369
3	Al, Cu, Steel, Stainless steel, Stinox, Al/Al	2.2	6.0	17/22 SL...	145 7351	-	145 7349	145 0668
3 and 3.2	Al, Cu, Steel, Stainless steel, Stinox, Al/Al, PG Al, PG steel	2.4	6.0	17/24 SL...	145 7370	145 7371	145 7372	145 7373
4	Al, Cu	2.4	6.0	17/24 SL...	145 7370	145 7371	145 7372	145 7373
4	Steel, PG Al	2.7	8.0	17/27 SL...	145 7374	145 7376	145 7377	143 5035
4	Stainless steel, Stinox, PG steel	3.0	8.0	17/29 SL...	145 7378	145 7379	145 7381	145 7382
4.8 and 5	Al, PG Al	3.0	8.0	17/29 SL...	145 7378	145 7379	145 7381	145 7382
4.8 and 5	Steel	3.35	8.0	17/32 SL...	145 7383	145 7385	145 7386	145 7388
4.8 and 5	Stainless steel, Stinox, PG steel	3.6	10.0	17/36 SL...	145 7390	145 7392	145 7393	145 7394
6	Al/Al	3.6	10.0	17/36 SL...	145 7390	145 7392	145 7393	145 7394
6	Steel	4.0	10.0	17/40 SL...	145 7399	145 7400	145 7401	145 7402
6.4	Al, Stainless steel, PG Al, PG steel and G-Bulb	4.5	10.0	17/45 SL...	145 7265	145 0673	145 7404	145 7398

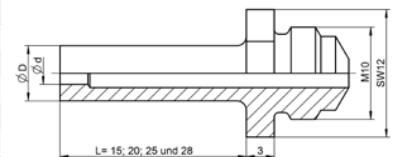

CAUTION! BLIND RIVETS MUST BE ORDERED AS A CUSTOM-MADE PRODUCT WITH EXTENDED MANDREL!

Plate nosepieces (for riveting soft and fragile materials)

Plate nosepiece P without cut-out

Rivet Ø	Rivet material	Ø d	Designation	SN 2, HN 2, PH 1, PH 2, PH 2-KA, PH-Axial, PH 2000		TAURUS® AccuBird® PowerBird®	
				Article no. Dome head	Designation	Article no.	
3 and 3,2	Al, Cu, Steel, Stainless steel, Stinox, Al/Al, PG Al, PG steel	2.4	P 16/24	145 6649	P 17/24	145 7335	
4	Al, Cu, CAP® Al, CAP® Cu	2.4	P 16/24	145 6649	P 17/24	145 7335	
4	Steel, Al/Al, PG Al	2.7	P 16/27	145 6650	P 17/27	145 7336	
4	Stainless steel, Stinox, PG steel	3.0	P 16/29	145 6651	P 17/29	145 7337	
4.8 and 5	Al, CAP® Al, CAP® Cu, PG Al	3.0	P 16/29	145 6651	P 17/29	145 7337	
4.8 and 5	Steel, Al/Al	3.35	P 16/32	145 6657	P 17/32	145 7338	
4.8 and 5	Stainless steel, Stinox, PG steel	3.6	P 16/36	145 6656	P 17/36	145 7339	
6	Al	3.6	P 16/36	145 6656	P 17/36	145 7339	

For countersunk head blind rivets

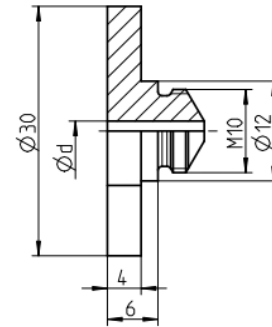
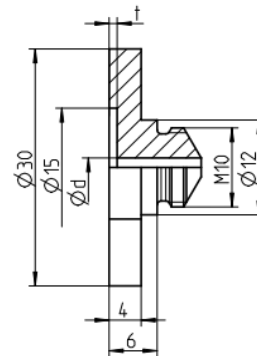

Plate nosepiece PA with cut-out

Rivet Ø	Rivet material	Ø d	Designation	Depth t	SN 2, HN 2, PH 1, PH 2, PH 2-KA, PH-Axial, PH 2000		TAURUS® AccuBird® PowerBird®	
					Article no. Dome head	Designation	Depth t	Article no.
3 and 3,2	Al, Cu, Steel, Stainless steel, Stinox, Al/Al, PG Al, PG steel	2.4	PA 16/24	1.0	145 6659	PA 17/24	1.0	145 7330
4	Al, Cu, CAP® Al, CAP® Cu	2.4	PA 16/24	1.0	145 6659	PA 17/24	1.0	145 7330
4	Steel, Al/Al, PG Al	2.7	PA 16/27	1.0	145 6660	PA 17/27	1.0	145 7331
4	Stainless steel, Stinox, PG steel	3.0	PA 16/29	1.1	145 6661	PA 17/29	1.1	145 7341
4.8 and 5	Al, CAP® Al, CAP® Cu, PG Al	3.0	PA 16/29	1.1	145 6661	PA 17/29	1.1	145 7341
5	Al-large flange K 11 and K 14	3.0	PA 16/29 K	1.5	145 6652	PA 17/29 K	1.5	145 7332
4.8 and 5	Steel, Al/Al	3.35	PA 16/32	1.1	145 6653	PA 17/32	1.1	145 7333
4.8 and 5	Stainless steel, Stinox, PG steel	3.6	PA 16/36	1.1	145 6662	PA 17/36	1.1	145 7342
6	Al	3.6	PA 16/36	1.3	145 6666	PA 17/36	1.3	145 7334

For standard blind rivets (dome head)



Pivot nosepieces PG for the production of articular rivet connections

Rivet Ø	Rivet material	Ø d	Designation	Depth t	SN 2, HN 2, PH 1, PH 2, PH 2-KA, PH-Axial, PH 2000		TAURUS® AccuBird® PowerBird®	
					Article no. Dome head	Designation	Depth t	Article no.
3 and 3,2	Al, Cu, Steel, Stainless steel, Stinox, Al/Al, PG Al, PG steel	2.4	PG 16/24	1.6	145 6663	PG 17/24	1.6	143 5002
4	Al, Cu, CAP® Al, CAP® Cu	2.4	PG 16/24	1.6	145 6663	PG 17/24	1.6	143 5002
4	Steel, Al/Al, PG Al	2.7	PG 16/27	1.6	145 6664	PG 17/27	1.6	143 5003
4	Stainless steel, Stinox, PG steel	3.0	PG 16/29	1.6	145 6655	PG 17/29	1.6	143 5007
4,8 and 5	Al, CAP® Al, CAP® Cu, PG Al	3.0	PG 16/29	1.6	145 6655	PG 17/29	1.6	143 5007
5	Al-large flange K 11 and K 14	3.0	PG 16/29 K	2.0	145 6658	PG 17/29 K	2.0	143 5004
5	Al-large flange K 16	3.0	-	-	-	PG 17/29 K16	2.0	143 5009
4,8 and 5	Steel, Al/Al	3.35	PG 16/32	1.6	145 6654	PG 17/32	1.6	143 5005
4,8 and 5	Stainless steel, Stinox, PG steel	3.6	PG 16/36	1.6	145 6665	PG 17/36	1.6	143 5006
6	Al	3.6	PG 16/36	2.0	146 4002	PG 17/36	2.0	145 7340

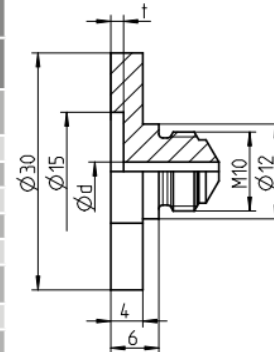

Pivot nosepiece PG (dimensions compare plate nosepiece „PA“)

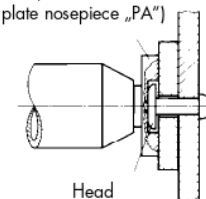

DELIVERY TIMES ON REQUEST!

Nosepieces for setting tools with spring-loaded trigger system

AccuBird® Pro, PowerBird® Pro Gold Edition and TAURUS® (as from march 2013)

Rivet Ø	Rivet material	Ø d	Ø D	Standard	Article no.	Extended version (8mm)	Article no.
2.4	Al	1.85	6.0	17/18 AV	143 5591	V-17/18 AV	145 7291
3.2	CAP® Al, CAP® copper	1.85	6.0	17/18 AV	143 5591	V-17/18 AV	145 7291
3	Al/Cu	2.0	6.0	17/20 AV	143 4990	V-17/20 AV	145 0666
3	Al, Cu, Steel, Stainless steel, Stinox, Al/Al	2.2	6.0	17/22 AV	143 4991	V-17/22 AV	145 0667
3 and 3.2	Al, Cu, Steel, Stainless steel, Stinox, Al/Al, PG Al, PG steel	2.4	6.0	17/24 AV	143 5592	V-17/24 AV	145 7292
4	Al, Cu, CAP® Al, CAP® Cu	2.4	6.0	17/24 AV	143 5592	V-17/24 AV	145 7292
4	Steel, Al/Al, PG Al	2.7	8.0	17/27 AV	143 5593	V-17/27 AV	145 0628
4	Stainless steel, Stinox, PG steel	3.0	8.5	17/29 AV	143 5594	V-17/29 AV	145 0629
4.8 and 5	Al, CAP® Al, CAP® Cu, PG Al	3.0	8.5	17/29 AV	143 5594	V-17/29 AV	145 0629
4.8 and 5	Steel, Al/Al	3.35	8.5	17/32 AV	143 5595	V-17/32 AV	145 7725
4.8 and 5	Stainless steel, Stinox, PG steel	3.6	10.0	17/36 AV	143 5596	V-17/36 AV	145 0630
6	Al	3.6	10.0	17/36 AV	143 5596	V-17/36 AV	145 0630
6	Steel	4.0	10.0	17/40 AV	143 5597	V-17/40 AV	145 7293
6.4	Al, PG Al	4.0	10.0	17/40 AV	143 5597	V-17/40 AV	145 7293
6.4	Steel, Al/Al	4.5	10.0	17/45 AV	143 5598	V-17/45 AV	145 0631

Standard version
17/.....Nosepieces

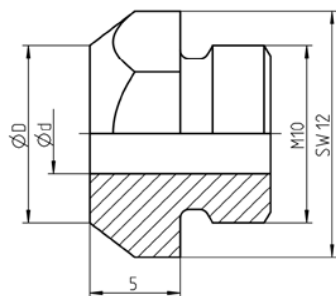

Extended version (8 mm)
V-17/.....Nosepieces

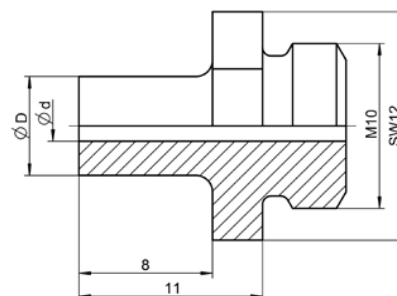

Lockbolt setting tools

TAURUS® 4 SRB with angle head 90° for 6.4mm (1/4") C6L and Magna-Grip® lockbolts

Spare part no.	Article no.	Designation
1	145 0977	Housing unit
2	145 0970	Protecting cap complete
3	143 5908	Bolt
4	143 5911	Bolt
5	143 5914	Spacer
6	143 5919	Fork head
7a	143 5993	Nosepiece C6L
7b	143 5942	Nosepiece Magna-Grip®
8	143 5952	Ring
9	143 5994	Head
10	143 5935	Piece
11a	143 5995	Supporting ring C6L
11b	143 5943	Supporting ring Magna-Grip®
12	143 5936	Angle
13	143 5938	Lock activator
14	143 5996	Lock activator
15	143 5959	Adapter
16a	144 6116	Jaw C6L
16b	144 6105	Jaw Magna-Grip®
17	143 5997	Housing
18	144 6013	Screw
19	144 6012	O-ring
20	144 5716	Washer
21	144 5545	Snap ring

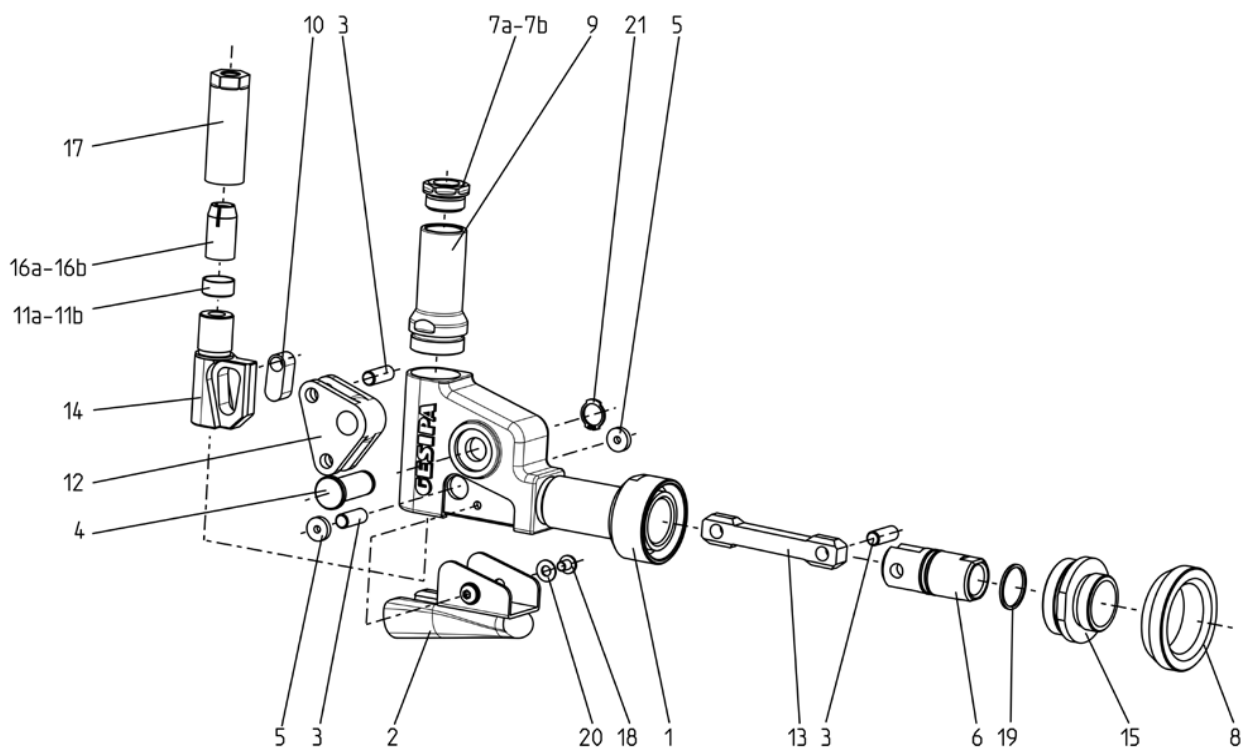

The suitability of nosepiece and fastener needs to be tested by the user and is user's own responsibility!

Nosepieces for setting tools with spring-loaded trigger system

AccuBird® Pro, PowerBird® Pro Gold Edition and TAURUS® (as from march 2013)

Rivet Ø	Rivet material	Ø d	Ø D	Designation	15 mm	20 mm	25 mm	28 mm
2.4	Al	1.85	6.0	17/18 AV SL...	145 0634	145 0635	145 0636	145 0637
3.2	CAP® Al, CAP® copper	1.85	6.0	17/18 AV SL...	145 0634	145 0635	145 0636	145 0637
3	Al/Cu	2.0	6.0	17/20 AV SL...	145 0658	145 0659	145 0660	145 0661
3	Al, Cu, Steel, Stainless steel, Stinox, Al/Al	2.2	6.0	17/22 AV SL...	145 0662	145 0663	145 0664	145 0665
3 and 3.2	Al, Cu, Steel, Stainless steel, Stinox, Al/Al, PG Al, PG steel	2.4	6.0	17/24 AV SL...	145 0638	145 7321	145 0639	145 0640
4	Al, Cu	2.4	6.0	17/24 AV SL...	145 0638	145 7321	145 0639	145 0640
4	Steel, PG Al	2.7	8.0	17/27 AV SL...	145 0641	145 7322	145 0642	145 7726
4	Stainless steel, Stinox, PG steel	3.1	8.0	17/29 AV SL...	145 7324	145 0643	145 7325	145 0644
4.8 and 5	Al, PG Al	3.1	8.0	17/29 AV SL...	145 7324	145 0643	145 7325	145 0644
4.8 and 5	Steel	3.35	8.0	17/32 AV SL...	145 0645	145 7326	145 0646	145 0647
4.8 and 5	Stainless steel, Stinox, PG steel	3.6	10.0	17/36 AV SL...	145 0648	145 0649	145 0650	145 0651
6	Al/Al	3.6	10.0	17/36 AV SL...	145 0648	145 0649	145 0650	145 0651
6	Steel	4.0	10.0	17/40 AV SL...	145 7327	145 7328	145 0652	145 0653
6.4	Al, Stainless steel, PG Al, PG steel and G-Bulb	4.5	10.0	17/45 AV SL...	145 0654	145 0655	145 0656	145 0657

CAUTION! BLIND RIVETS MUST BE ORDERED AS A CUSTOM-MADE PRODUCT WITH EXTENDED MANDREL!

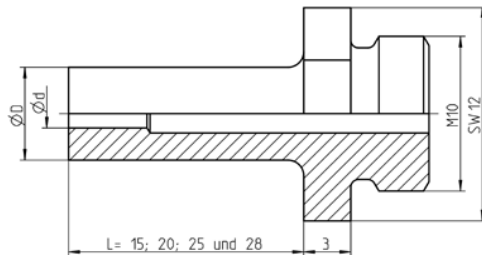

Lockbolt setting tools

TAURUS® 5 compact SRB – tool no longer available

Spare part no.	Article no.	Designation
1	145 1000	Tool head
2	144 6013	Oil screw plug
3	143 5612	Sealing ring M4
4	143 6044	O-ring
5 •	143 6045	O-ring
6	145 8011	Seal holder, complete
7 •	143 6047	O-ring
8 •	143 6048	Rod seal
9	143 6036	Draw bar
10 •	143 6049	Piston seal
11 •	143 6052	Supporting ring
12 •	143 6051	Quad sealing ring
13	143 6046	O-ring
14	145 8012	Resetting piston, complete
15	143 6050	Piston seal
16 •	143 6053	Rod seal
17	144 6123	Spring
18	143 6030	Connecting piece
19	144 6124	Snap ring
20	144 6125	Washer
21	143 6042	O-ring
22	143 6043	O-ring
23	143 6034	End cap
24	144 6122	Retaining spring
25	143 6026	Retainer
26	143 6028	Adapter
27	143 6025	Lock washer
28	143 6029	Connecting piece nut
29	143 6058	Spent mandrel container, complete
30	145 7748	Grip, complete
31 •	143 5472	Flat gasket 1
32	144 6025	Activation button
33	143 5642	Slider
34	143 5686	Orifice
35 •	143 5480	Flat gasket 2
36	145 1001	Air cylinder, complete
37	143 5484	O-ring
38	145 7750	Pressure relief valve, complete
39	145 7956	Silencer complete
40	144 6030	Sealing ring
41	143 5667	Connecting nipple

Spare part no.	Article no.	Designation
42	143 5648	Spacer cage
43	143 5647	Rod seal
44	143 5651	Control piston
45 •	143 5670	Piston seal
46	143 5652	Piston housing
47	143 5688	O-ring
48	144 5773	Screw
49	144 6100	Stopper
50	143 5486	O-ring
51	143 5492	Al nut
52 •	143 5841	Piston seal
53 •	143 5825	Guide ring
54	145 7952	Air piston complete
55 •	143 5937	O-ring
56	143 5635	Rod seal
57	144 6082	Snap ring
58	143 5927	O-ring
59	145 7953	Cylinder complete
60	143 5874	Bottom
61	143 5900	Rubber foot
	144 5294	Hydraulic oil refill bottle, 100 ml

• Wearing parts

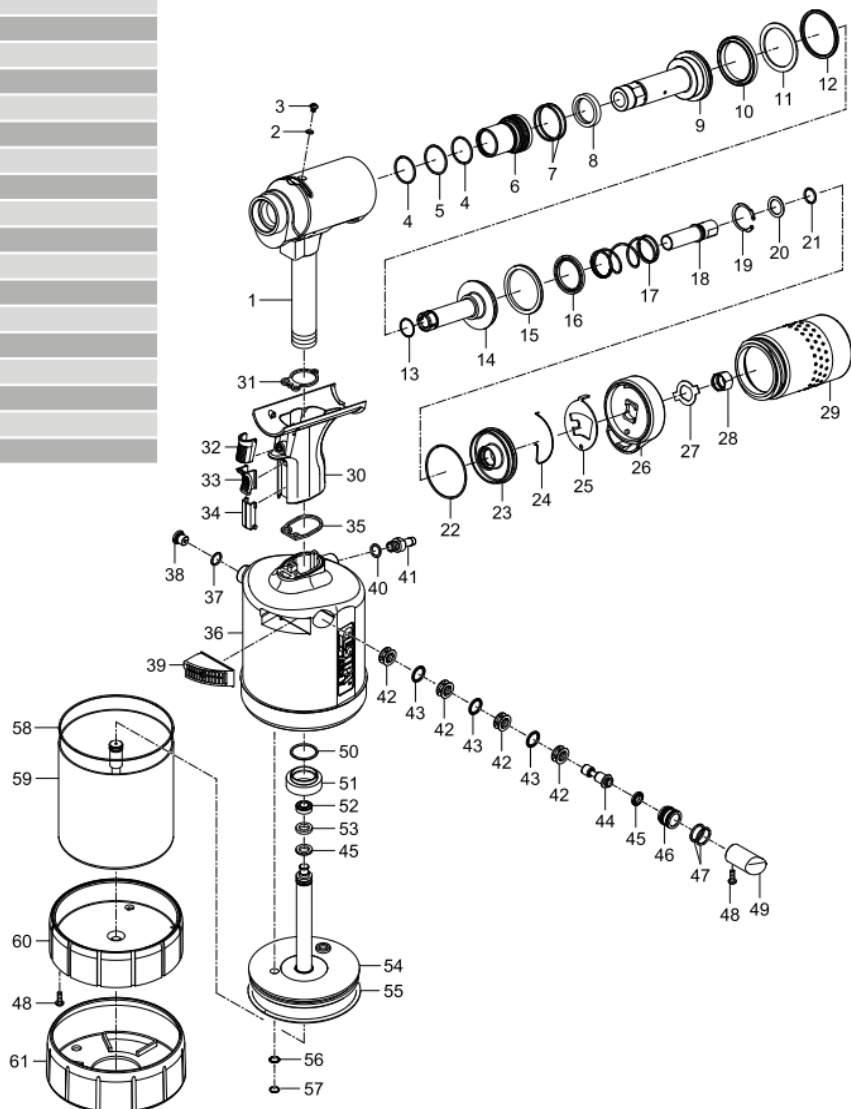

Lockbolt setting tools up to April 2015

Head modules TAURUS® 3 SRB

for 4.8mm (3/16") C6L and Magna-Grip® lockbolts

Spare part no.	Article no.	Designation
1 •	143 6078	Nosepiece C6L
2 •	143 6083	Nosepiece Magna-Grip®
3	143 5909	Steel head sleeve
4 •	143 6085	Jaw for C6L*
5 •	143 6082	Jaw for Magna-Grip®*
6 •	144 6012	O-ring
7 •	143 6002	Jaw housing
8 •	143 6000	Jaw pusher
9	143 5999	Damping ring
10	143 6001	Centre part
11	143 5886	Nozzle tube
12	143 5964	Spent mandrel container, complete

• Wearing parts

* For changing the complete set you have to order 3 Jaws

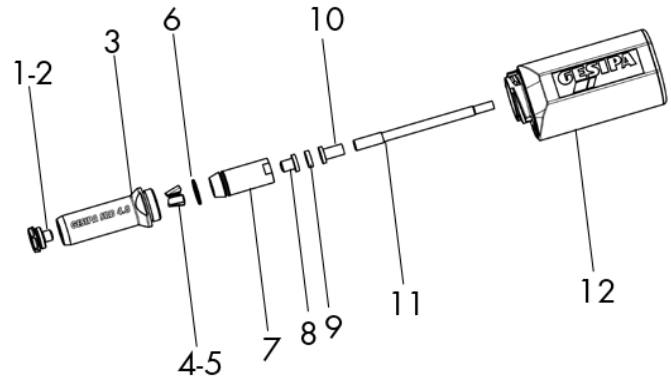

Head modules TAURUS® 5 compact SRB

for 4.8mm (3/16") C6L and Magna-Grip® lockbolts

Spare part no.	Article no.	Designation
1 •	143 6078	Nosepiece C6L
2 •	143 6083	Nosepiece Magna-Grip®
3	143 6086	Steel head sleeve 4.8
4 •	143 6085	Jaw for C6L**
5 •	143 6082	Jaw for Magna-Grip®**
6 •	143 6044	O-ring
7 •	143 6070	Jaw housing
8 •	143 6068	Jaw pusher
9	143 6064	Damping ring
10	143 6069	Centre part
11	145 8016	Nozzle tube complete

• Wearing parts

** For changing the complete set you have to order 4 Jaws

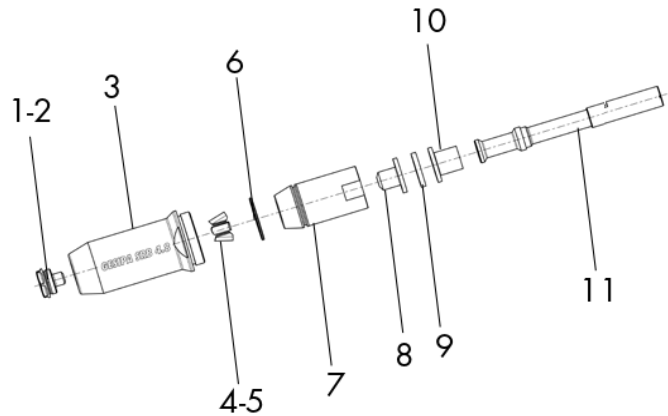

for 6.4mm (1/4") C6L and Magna-Grip® lockbolts

Spare part no.	Article no.	Designation
1 •	143 6079	Nosepiece C6L
2 •	143 6084	Nosepiece Magna-Grip®
3	143 6087	Steel head sleeve 6.4
4 •	143 6075	Jaw for C6L***
5 •	143 6076	Jaw for Magna-Grip®***
6 •	143 6044	O-ring
7 •	143 6081	Jaw housing
8 •	143 6061	Jaw pusher
9	143 6064	Damping ring
10	143 6062	Centre part
11	143 6065	Nozzle tube complete

• Wearing parts

*** For changing the complete set you have to order 5 Jaws

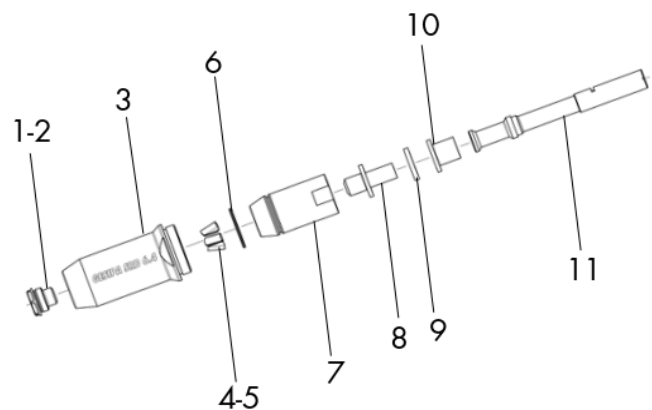

The suitability of nosepiece and fastener needs to be tested by the user and is user's own responsibility!

Lockbolt setting tools up to April 2015

Head modules for PowerBird® SRB

for 4,8mm (3/16") C6L and Magna-Grip® lockbolts

Spare part no.	Article no.	Designation
1 •	143 6078	Nosepiece C6L
2 •	143 6083	Nosepiece Magna-Grip®
3	143 4806	Steel head sleeve 4, 8
4 •	143 6085	Jaw for C6L*
5 •	143 6082	Jaw for Magna-Grip®*
6 •	144 6012	O-ring
7 •	143 5574	Jaw housing
8 •	143 4852	Jaw pusher

• Wearing parts

* For changing the complete set you have to order 3 Jaws

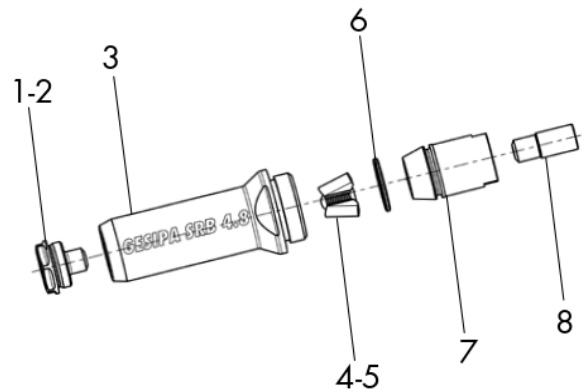

for 6,4mm (1/4") C6L and Magna-Grip® lockbolts

Spare part no.	Article no.	Designation
1 •	143 6079	Nosepiece C6L
2 •	143 6084	Nosepiece Magna-Grip®
3	143 4807	Steel head sleeve 6.4
4 •	143 6075	Jaw for C6L***
5 •	143 6076	Jaw for Magna-Grip®***
6 •	143 6044	O-ring
7 •	143 6081	Jaw housing
8 •	143 6061	Jaw pusher
9	143 6064	Damping ring
10	143 6062	Centre part
11	143 4858	Spring
12	143 4856	Connector
13	143 4854	Ejector
14	143 4857	Spring
15	143 6158	Adapter
16	143 4928	End cap

• Wearing parts

*** For changing the complete set you have to order 5 Jaws

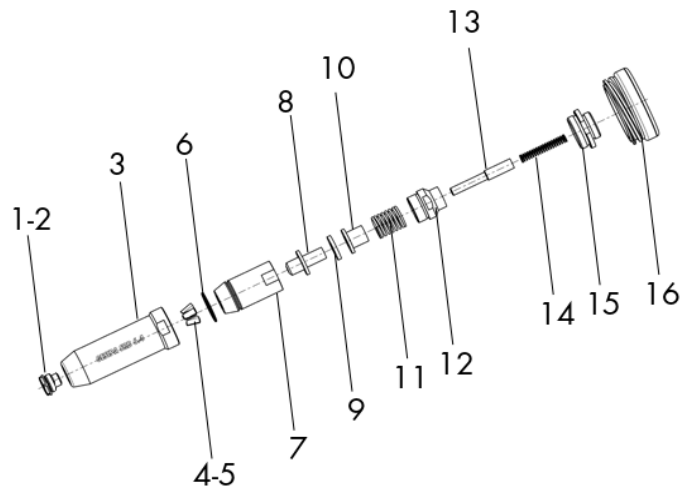

The suitability of nosepiece and fastener needs to be tested by the user and is user's own responsibility!

Lockbolt setting tools up to May 2015

TAURUS® 3 SRB

for 4,8mm (3/16") C6L and Magna-Grip® lockbolts

TAURUS® 4 SRB

for 6,4mm (1/4") C6L and Magna-Grip® lockbolts

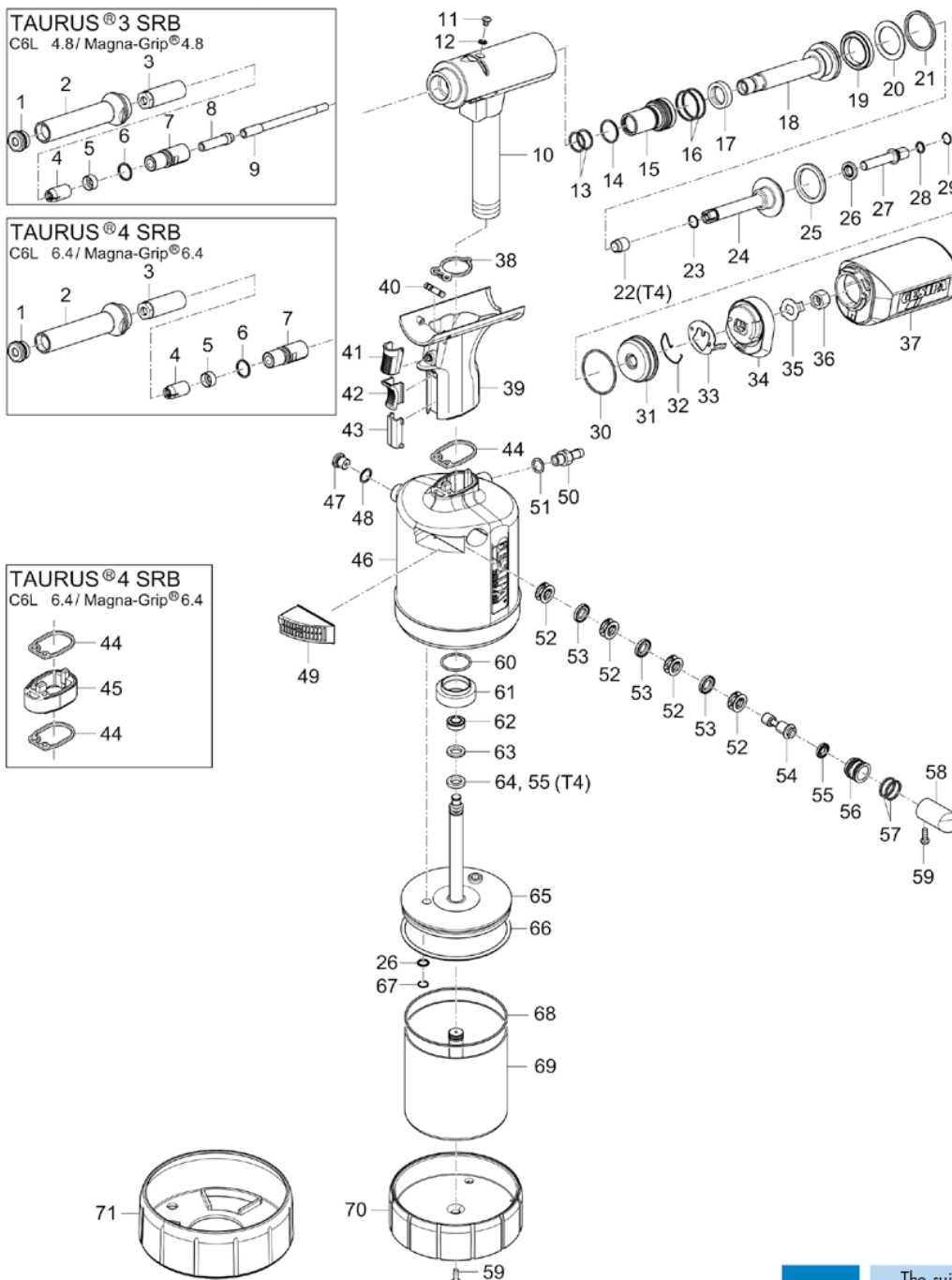

! The suitability of nosepiece and fastener needs to be tested by the user and is user's own responsibility!

Lockbolt setting tools up to May 2015

TAURUS® 3 SRB

for 4,8mm (3/16") C6L and Magna-Grip® lockbolts

TAURUS® 4 SRB

for 6,4mm (1/4") C6L and Magna-Grip® lockbolts

Spare part no.	TAURUS®-Type	Article no.	Designation
1 •	T3	143 4809	Nosepiece C6L
		143 4810	Nosepiece Magna-Grip®
	T4	143 5993	Nosepiece C6L
		143 5942	Nosepiece Magna-Grip®
2		143 5923	Steel head sleeve
3	T3	143 5944	Clamping jaw housing C6L
		143 5945	Clamping jaw housing Magna-Grip®
	T4	143 5997	Clamping jaw housing
		144 6117	Clamping jaw C6L
4 •	T3	144 6118	Clamping jaw Magna-Grip®
		144 6116	Clamping jaw C6L
	T4	144 6105	Clamping jaw Magna-Grip®
		143 5995	Supporting ring C6L
5	T4	143 5943	Supporting ring Magna-Grip®
6		143 6042	O-ring
7		143 5924	Adapter
8	T3	143 5920	Sleeve
9	T3	143 5886	Nozzle tube 3, longe
10	T3	145 7856	Tool head 2, assembled
	T4	145 7992	Tool head 4, assembled
11		144 6013	Oil screw plug
12		143 5612	Sealing ring M4
13		144 6012	O-ring
14		143 5629	O-ring
15		143 5681	Seal holder, complete
16 •		143 4227	O-ring
17		143 5630	Rod seal
18		143 5631	Draw bar
19		143 5632	Piston seal
20		143 5488	Supporting ring
21		143 5485	Piston seal
22	T4	145 0965	Spacer sleeve
23		143 5671	O-ring
24		145 7746	Resetting piston, complete
25		143 5633	Piston seal
26		143 5635	Rod seal
27		143 5765	Connecting piece 2/3
28		143 5519	O-ring
29		144 6167	Snap ring
30		143 5524	O-ring
31		143 5532	End cap
32		144 6028	Retaining spring
33		143 5664	Retainer
34		143 5663	Adapter
35		143 5842	Lock washer
36		143 5766	Connecting piece nut 2/3
37		143 5964	Spent mandrel container, complete
38		143 5472	Flat gasket 1
39		145 7748	Grip, complete
40		145 7747	Distributing valve, complete
41		144 6025	Activation button
42		143 5642	Slider
43		143 5686	Orifice
44		143 5480	Flat gasket 2

Spare part no.	TAURUS®-Type	Article no.	Designation
45	T4	143 5998	Grip extension
46	T3	145 0960	Air cylinder 3, complete
	T4	145 0996	Air cylinder 4, complete
47		145 7750	Pressure relief valve, complete
48		143 5484	O-ring
49		145 7956	Silencer 3, complete
50		143 5667	Connecting nipple
51		144 6030	Sealing ring
52		143 5648	Spacer cage
53		143 5647	Rod seal
54		143 5651	Control piston
55		143 5675	Piston seal
56		143 5652	Piston housing
57		143 5688	O-ring
58		144 6100	Stopper 3
59		144 5773	Housing screw short
60		143 5486	O-ring
61		143 5492	Al nut
62	T3	143 5841	Piston seal
	T4	143 6007	Piston seal
63	T3	143 5825	Guide ring 2
	T4	143 6006	Guide ring 4
64	T3	143 5670	Piston seal
65	T3	145 7952	Air piston 3, complete
	T4	145 7994	Air piston 4, complete
66		143 5937	O-ring
67		144 6082	V profile ring
68		143 5927	O-ring
69	T3	145 7953	Cylinder 3, complete
	T4	145 7995	Cylinder 4, complete
70		143 5874	Bottom 3
71		143 5900	Rubber foot 3 - 4
		144 5294	Hydraulic oil refill bottle, 100 ml

• Wearing parts



The suitability of nosepiece and fastener needs to be tested by the user and is user's own responsibility!

Lockbolt setting tools from May 2015

PowerBird® SRB

for 4.8mm (3/16") C6L and Magna-Grip® lockbolts
for 6.4mm (1/4") C6L and Magna-Grip® lockbolts

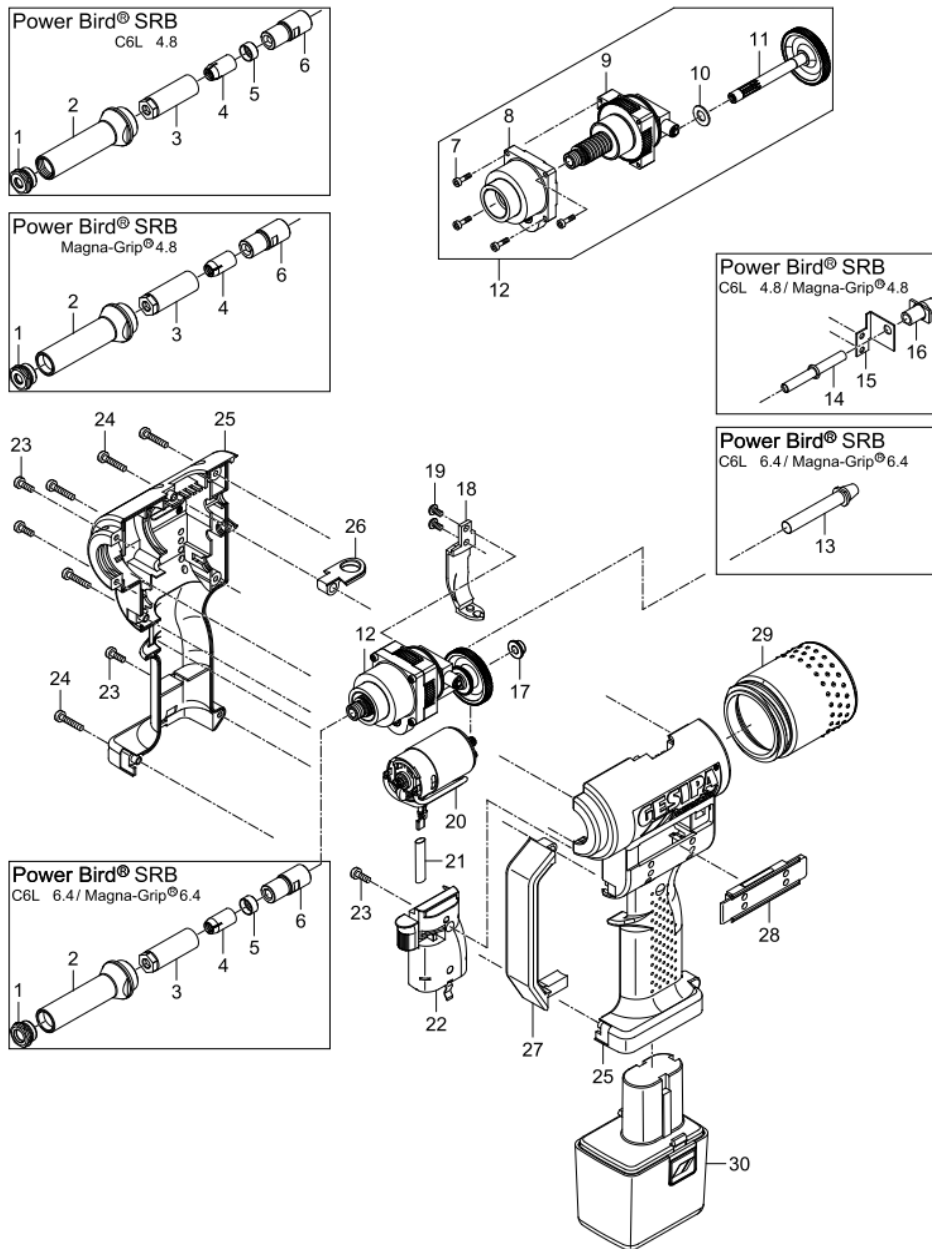

The suitability of nosepiece and fastener needs to be tested by the user and is user's own responsibility!

Lockbolt setting tools from May 2015

PowerBird® SRB

for 4.8mm (3/16") C6L and Magna-Grip® lockbolts
for 6.4mm (1/4") C6L and Magna-Grip® lockbolts

Spare part no.	SRB-Type	Article no.	Designation
1	4.8	143 4809	Nosepiece C6L
		143 4810	Nosepiece Magna-Grip®
	6.4	143 5993	Nosepiece C6L
		143 5942	Nosepiece Magna-Grip®
2	4.8 + 6.4	143 4811	Steel head sleeve
3	4.8	143 5944	Clamping jaw housing C6L
		143 5945	Clamping jaw housing Magna-Grip®
	6.4	143 5997	Clamping jaw housing
4	4.8	144 6117	Clamping jaw C6L
		144 6118	Clamping jaw Magna-Grip®
	6.4	144 6116	Clamping jaw C6L
		144 6105	Clamping jaw Magna-Grip®
5	4.8 + 6.4	143 5995	Supporting ring C6L
	6.4	143 5943	Supporting ring Magna-Grip®
6	4.8	143 4812	Adapter
	6.4	143 4813	Adapter
7		144 5768	Allen screw
8		143 5027	Bearing complete
9	4.8	143 4867	Ball screw drive, assembled
	6.4	143 5079	Ball screw drive, assembled
10		143 4967	Washer
11	4.8	143 5028	Pinion shaft complete
	6.4	143 5088	Pinion shaft complete
12	4.8	145 0612	Drive complete
	6.4	145 0613	Drive complete
13		143 4808	End tube
14	6.4	143 4871	PB tube
15	6.4	143 4873	Angle
16	6.4	143 4874	P tube short
17		144 5763	Sintered-metal bushing
18		143 5031	Holder
19		144 5769	Fillister head screw
20		143 4862	Motor
21		144 5774	Hose, Silikon
22	4.8	143 4893	E-Control
	6.4	143 5020	E-Control
23		144 5773	Screw
24		144 5772	Screw
25		143 4845	Housing, complete
26		143 5416	Hanger
27		143 4953	Protection bracket
28		143 5062	Cover
29		143 5032	Spent mandrel container, complete
30		143 4923	Accu

• Wearing parts



The suitability of nosepiece and fastener needs to be tested by the user and is user's own responsibility!

Blind rivet hand nut setting tools

GBM 5

Spare part no.	Article no.	Designation
5-1	145 7165	Tool housing
5-2	145 7166	Tool shanks
5-4	145 6603	Sleeve grip for tool housing no. 5-1
5-5	145 6604	Sleeve grip for tool housing no. 5-2
5-6	145 7167	Bolt
5-20	145 7168	Snap ring
5-21	145 6608	Supporting chain
5-22	145 6609	Spring dowel sleeve
5-23 •	145 6610	Self opening spring
5-25	145 7169	Lock activator
5-26	145 7170	Adjustment ring
5-27	145 7171	Knurled nut
5-28	145 7172	Locking nut
5-29 •	145 7173	Nosepiece M 4
5-30 •	145 7174	Nosepiece M 5
5-31 •	145 7175	Nosepiece M 6
5-32 •	145 7176	Threaded mandrel M 4
5-33 •	145 7177	Threaded mandrel M 5
5-34 •	145 7178	Threaded mandrel M 6
17	143 4079	Maintenance wrench SW 10

• Wearing parts

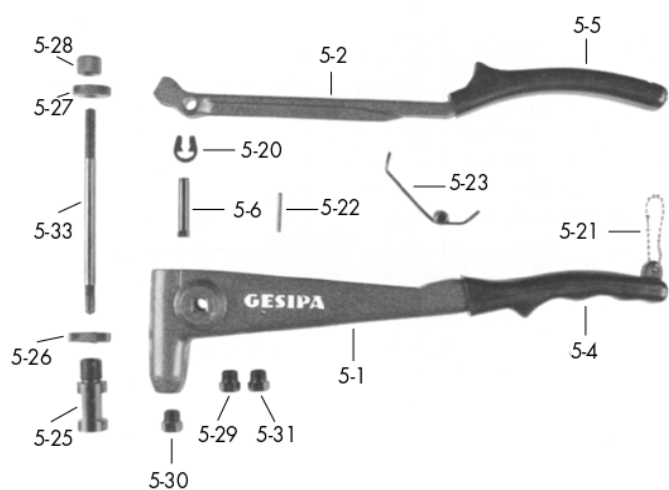

GBM 10

Spare part no.	Article no.	Designation
101	145 7092	Tool housing with sleeve grip no. 115
102	145 6627	Tool shanks with sleeve grip no. 116
103	143 4772	Lock activator
107	145 7094	Stop screw with scale label
108	143 4773	Locking nut
109	143 4074	Lever
112	143 4076	Bolt
113	143 4075	Bolt
114	144 5259	Snap ring
115	150 9066	Sleeve grip for tool housing no. 101
116	150 9068	Sleeve grip for tool housing no. 102
120•	144 5261	Self opening spring
130•	145 7096	Threaded mandrel M 3
140•	143 4776	Threaded mandrel M 4
150•	143 4779	Threaded mandrel M 5
160•	143 4781	Threaded mandrel M 6
131	145 7095	Nosepiece M 3
141 •	143 4777	Nosepiece M 4 and 8-32"
151 •	143 4780	Nosepiece M 5 and 10-32"
161 •	143 4782	Nosepiece M 6 and 1/4-20"
162	144 5739	Coil spring
A 140	143 4784	Threaded mandrel 8-32"
A 150	143 4783	Threaded mandrel 10-32"
A 160	143 4785	Threaded mandrel 1/4-20"

• Wearing parts

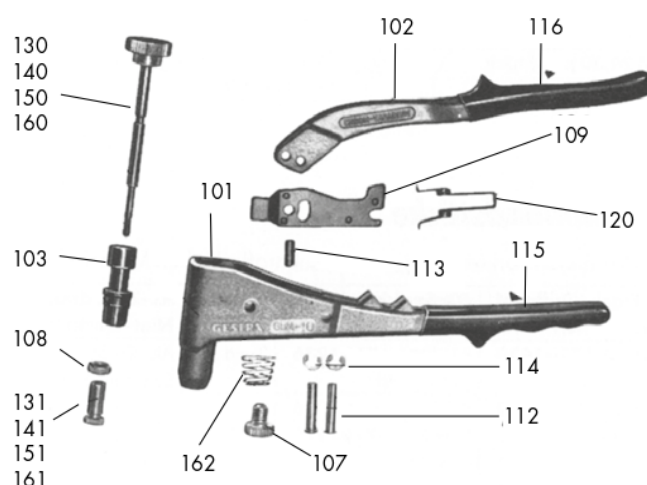

Blind rivet hand nut setting tools

GBM 30

Spare part no.	Article no.	Designation
301	145 7138	Housing, complete with bearing
302	145 7139	Radial bearing complete with guide sleeve
303	145 7140	Lever
304	145 7141	Bolt
311	145 7143	Bolt
312	145 7115	Snap ring
313	145 7145	Threaded sleeve with scale ring
314	145 7146	Locking nut M 26 x 1.5
315	145 7147	Locking nut M 20 x 1.5
316	145 7148	Articulated lever
317	145 7149	Drill part, complete
330 •	143 4799	Threaded mandrel M 3
340 •	143 4801	Threaded mandrel M 4
350 •	143 4791	Threaded mandrel M 5
360 •	143 4793	Threaded mandrel M 6
380 •	143 4795	Threaded mandrel M 8
390 •	143 4797	Threaded mandrel M 10
331 •	143 4800	Nosepiece M 3
341 •	143 4802	Nosepiece M 4
351 •	143 4792	Nosepiece M 5
361 •	143 4794	Nosepiece M 6
381 •	143 4796	Nosepiece M 8
391 •	143 4798	Nosepiece M 10
A 350	145 7158	Threaded mandrel 10-32"
A 360	145 7160	Threaded mandrel 1/4-20"
A 380	145 7159	Threaded mandrel 5/16-18"
A 390	145 7161	Threaded mandrel 3/8-16"
A 351 •	143 4792	Nosepiece 10-32" (M 5)
A 361 •	145 7162	Nosepiece 1/4-20"
A 381 •	145 7163	Nosepiece 5/16-18"
A 391 •	145 7164	Nosepiece 3/8-16"

• Wearing parts

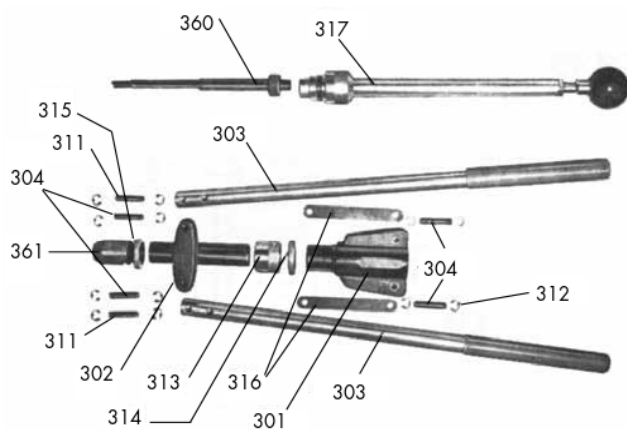

Blind rivet hand nut setting tools

FireFly

Spare part no.	Article no.	Designation
1	143 4005	Housing, complete with sleeve grip
2	143 3967	Pivot bolt
3	143 3968	Snap ring
4	143 3964	Sleeve grip for housing no. 1
5	143 3976	Bolt
6	143 3974	Drive pawl
7	143 3979	Spring dowel sleeve
8	143 3977	Self opening spring
9	143 3973	Sleeve grip for operating lever no. 10
10	145 6591	Operating lever with sleeve grip
11	143 3978	Retaining spring
12	143 3975	Storage finger (3-part) per set
13 / M3	143 3995	Nosepiece - bit
13 / M4	143 3994	Nosepiece - bit
13 / M5	143 3993	Nosepiece - bit
13 / M6	143 3997	Nosepiece - bit
13 / 6-32 UNC	143 4024	Nosepiece - bit
13 / 8-32 UNC	143 4025	Nosepiece - bit
13 / 10-24 UNC	143 4026	Nosepiece - bit

Spare part no.	Article no.	Designation
13 / 1/4"-20 UNC	143 4027	Nosepiece - bit
14 / M3	143 4002	Threaded mandrel
14 / M4	143 4001	Threaded mandrel
14 / M5	143 4000	Threaded mandrel
14 / M6	143 4008	Threaded mandrel
14 / 6-32 UNC	143 4019	Threaded mandrel
14 / 8-32 UNC	143 4020	Threaded mandrel
14 / 10-24 UNC	143 4021	Threaded mandrel
14 / 10-32 UNF	143 4022	Threaded mandrel
14 / 1/4"-20 UNC	143 4023	Threaded mandrel
15	143 5671	O-ring
16	143 3999	Nosepiece
17	144 5251	Knurled nut
18	144 5253	Snap ring
19	145 6595	Lock activator, complete
20	143 3972	Return spring
21	145 6594	Adjusting unit
22	143 3998	Knurled handle
23	144 5252	Spring dowel sleeve

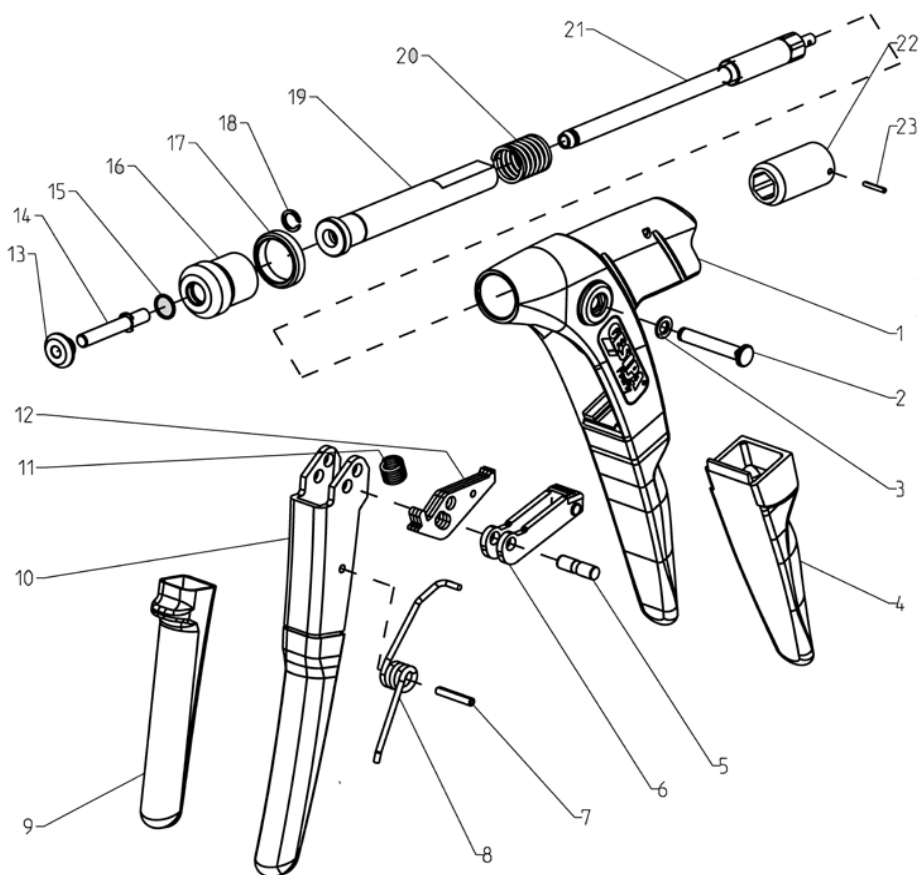

Battery powered blind rivet nut setting tools

FireBird® and FireBird® Gold Edition* – *tool no longer available

Spare part no.	Article no.	Designation	
1 •	143 5065	Nosepiece M 3	
	143 5066	Nosepiece M 4	
	143 5093	Nosepiece 8 - 32 UNC	
	143 5067	Nosepiece M 5	
	143 5094	Nosepiece 10 - 32 UNF	
	143 5068	Nosepiece M 6	
	143 5095	Nosepiece 1/4" - 16 UNC	
	143 5069	Nosepiece M 8 and 5/16" - 18UNC	
	143 5070	Nosepiece M 10	
	145 7459	Nosepiece 3/8" - 16 UNC	
	2 •	143 5052	Threaded mandrel M 3
		143 5055	Threaded mandrel M 4
		143 5090	Threaded mandrel 8 - 32 UNC
		143 5056	Threaded mandrel M 5
143 5091		Threaded mandrel 10 - 32 UNC	
143 5059		Threaded mandrel M 6	
143 5092		Threaded mandrel 1/4" - 20 UNC	
143 5063		Threaded mandrel M 8	
145 7457		Threaded mandrel 5/16" - 18 UNC	
143 5064		Threaded mandrel M 10	
145 7458	Threaded mandrel 3/8" - 16 UNC		
3	143 5053	Slider	
4	144 5805	Compression spring	
5	143 5073	Locking nut 2	
6	143 5124	Adjusting sleeve	
7	143 5074	Locking nut 1	
8	143 5075	Head	
9	143 5076	Driver	
10	143 5122	Bevel washer	
11	144 5804	Washer	
12	143 5120	Lock washer	
13	144 5823	Snap ring	
14	143 5077	Lock activator	
15	143 5078	Spacer	
16	144 5791	Washer	
17	144 5789	Shim ring, together	
18	144 5790	Retaining washer	
19	144 5768	Cylinder screw	
20	143 5027	Bearing, complete	
21	143 5079	Ballscrew drive, complete	
22	143 5088	Pinion shaft, complete	
23	143 5080	Rotating rod, complete	

Spare part no.	Article no.	Designation
24	143 5115	Coupling complete (Item 25-38)
25	144 5792	Countersunk screw
26	143 5081	Plate
27	143 5082	Rotary tappet
28	143 5083	Washer
29	144 5793	Compression spring
30	143 5084	Wrap spring
31	143 5085	Shaft
32	144 5794	Axial needle bearing
33	143 5086	Coupling
34	144 5795	Axial disc
35	152 4564	Bushing
36	144 5797	Shim ring, together
37	144 5798	Spring washer
38	144 5799	Snap ring
39	145 7455	Drive complete (Pos. 3-38)
40	144 5763	Sintered-metal bushing
41	144 5800	Cap
42	143 5031	Magnetic holder, complete
43	144 5770	Spring washer
44	144 5769	Magnetic holder screw
45	145 7456	E-control
46	144 5774	Hose, silicone
47 •	143 5030	Motor, complete
	143 4862	Motor, complete Gold Edition
48	144 5773	Housing screw, short
49	144 5772	Housing screw, long
50	143 4845	Housing, complete
51	143 5017	Hanger
	144 5746	Hanger Gold Edition
52	154 1150	Cover
53	143 4953	Protection bracket
54	143 5071	Accessories magazine
	144 5803	Hexagon screwdriver
		Threaded mandrel SL
		Nosepieces SL
	144 5806	Double-ended open-jawed wrench SW 24/27

• Wearing parts

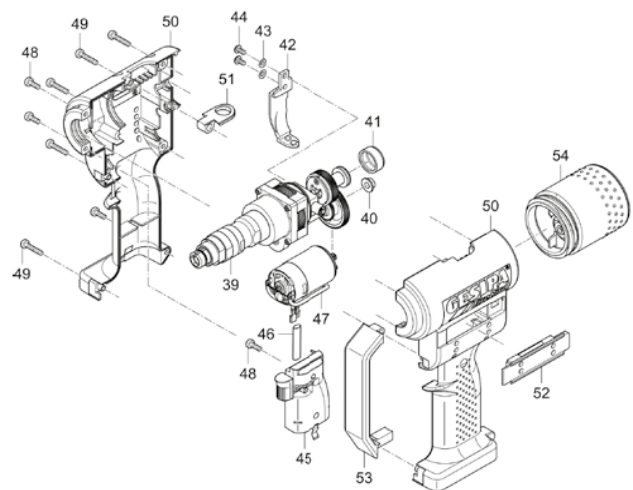
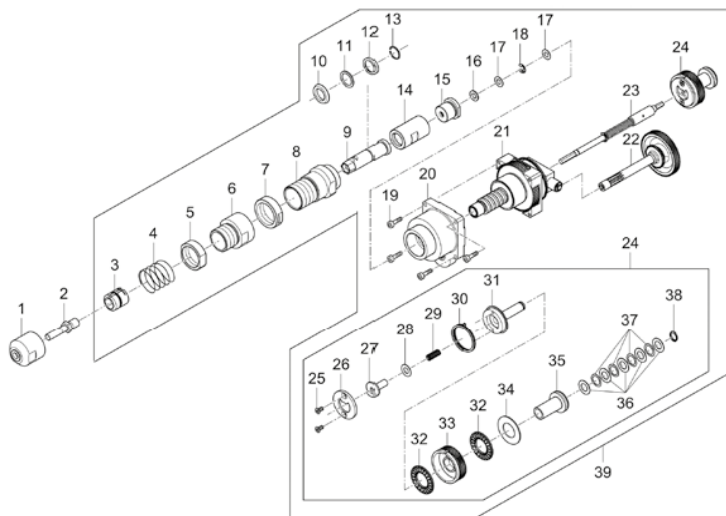

Blind rivet hand nut setting tools

FireBird® Pro and FireBird® Pro Gold Edition

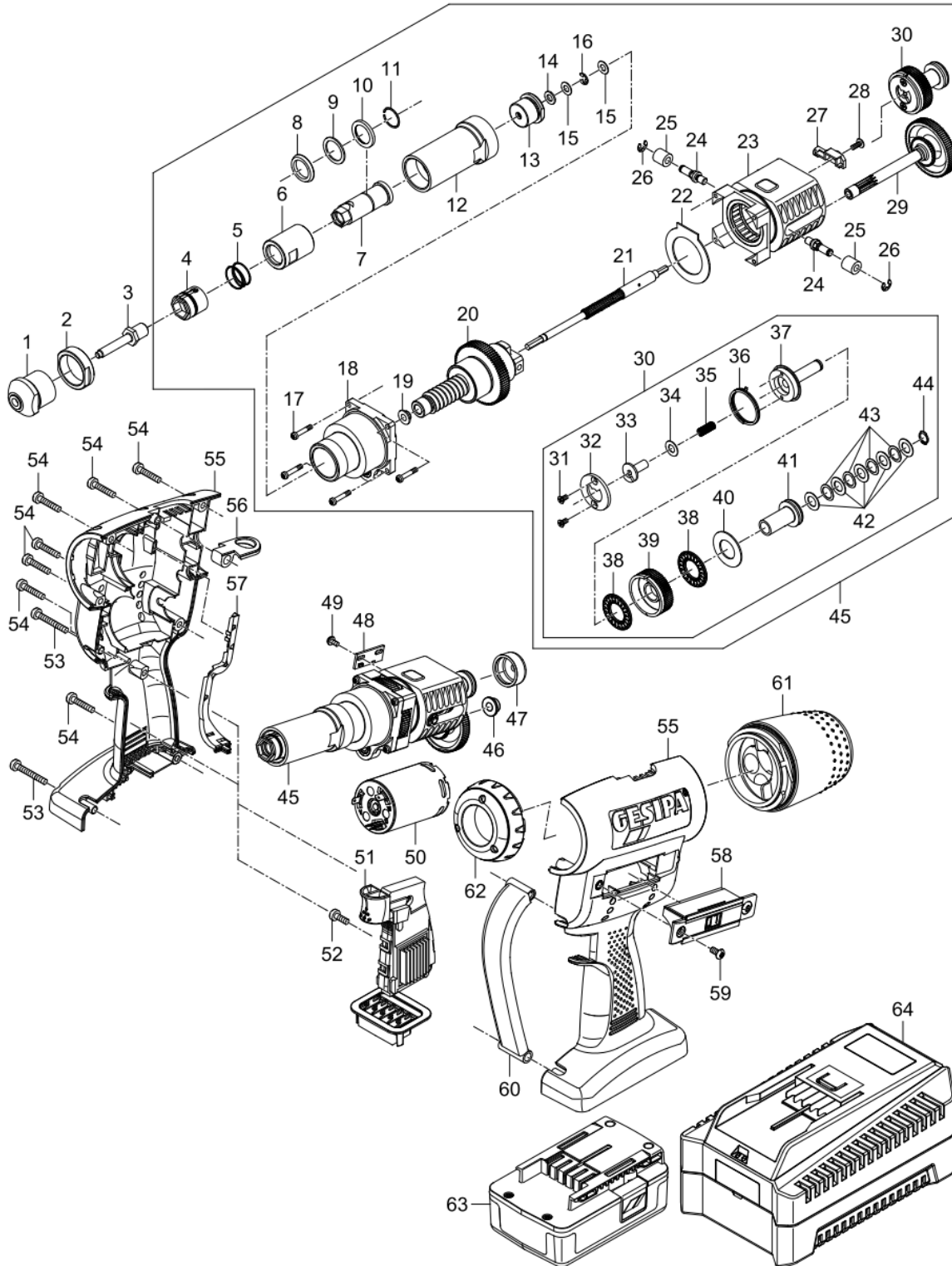

Battery powered blind rivet nut setting tools

FireBird® Pro and FireBird® Pro Gold Edition

Spare part no.	Article no.	Designation
1	143 6218	Nosepiece M3
	143 6219	Nosepiece M4
	143 6220	Nosepiece M5
	143 6221	Nosepiece M6
	143 6222	Nosepiece M8
	143 6223	Nosepiece M10
2	143 6193	Locking nut
3	143 6211	Threaded mandrel M3
	143 6212	Threaded mandrel M4
	143 6213	Threaded mandrel M5
	143 6214	Threaded mandrel M6
	143 6215	Threaded mandrel M8
	143 6216	Threaded mandrel M10
4	145 8123	Slider
5	143 6247	Spring
6	145 0851	Lock activator
7	152 4566	Driver
8	149 9358	Bevel washer
9	149 9377	Washer
10	149 9374	Lock washer
11	149 9375	Snap ring
12	145 0845	Head
13	149 9356	Spacer
14	144 5791	Washer
15	144 5789	Washer
16	144 5790	Snap ring
17	144 5768	Screw
18	152 4565	Bearing, complete
19	144 5776	Bearing
20	145 0849	Ball screw drive
21	152 4563	Rotating rod, complete
22	143 4962	Pressure disc
23	143 5397	Bearing cage
24	143 5385	Pin holder
25	143 4970	Sintered metal roller
26	144 5790	Lock washer
27	145 0817	Magnetic holder
28	144 5990	Screw
29	152 4568	Pinion shaft
30	143 5115	Coupling complete
31	144 5792	Countersunk screw
32	143 5081	Plate

Spare part no.	Article no.	Designation
33	143 5082	Rotary tappet
34	143 5083	Washer
35	144 5793	Spring
36	143 5084	Wrap spring
37	143 5085	Shaft
38	144 5794	Needle bearing
39	143 5086	Coupling
40	144 5795	Axial disc
41	152 4564	Coupling bush assy
42	144 5797	Washer
43	144 5798	Spring washer
44	144 5799	Snap ring
45	152 4562	Drive unit
46	144 5763	Sintered-metal bushing
47	144 5800	Drive
48	143 5408	Hall pcb
49	144 5989	Screw
50	145 7645	Motor
51	145 0855	Control FireBird® Pro Gold Edition
	152 4675	Control FireBird® Pro
52	144 5773	Screw
53	144 5987	Screw
54	144 5772	Screw
55	143 5401	Housing, complete
56	143 5017	Hanger FireBird® Pro
	144 5746	Hanger FireBird® Pro Gold Edition
57	143 5403	Cable duct
58	154 7988	Setting force control FireBird® Pro
	149 9398	Setting force control FireBird® Pro Gold Edition
59	144 9267	Screw
60	143 5399	Tool bar
61	149 9453	Accessories magazine
62	145 7644	Light, complete
63	145 7641	Battery
64	145 7642	Battery charger (EU)
	145 0818	Battery charger (UK)
	145 7649	Battery charger (USA)
	145 0819	Battery charger (CN)

Hydro-pneumatic blind rivet nut setting tools

Firefox® 1 F

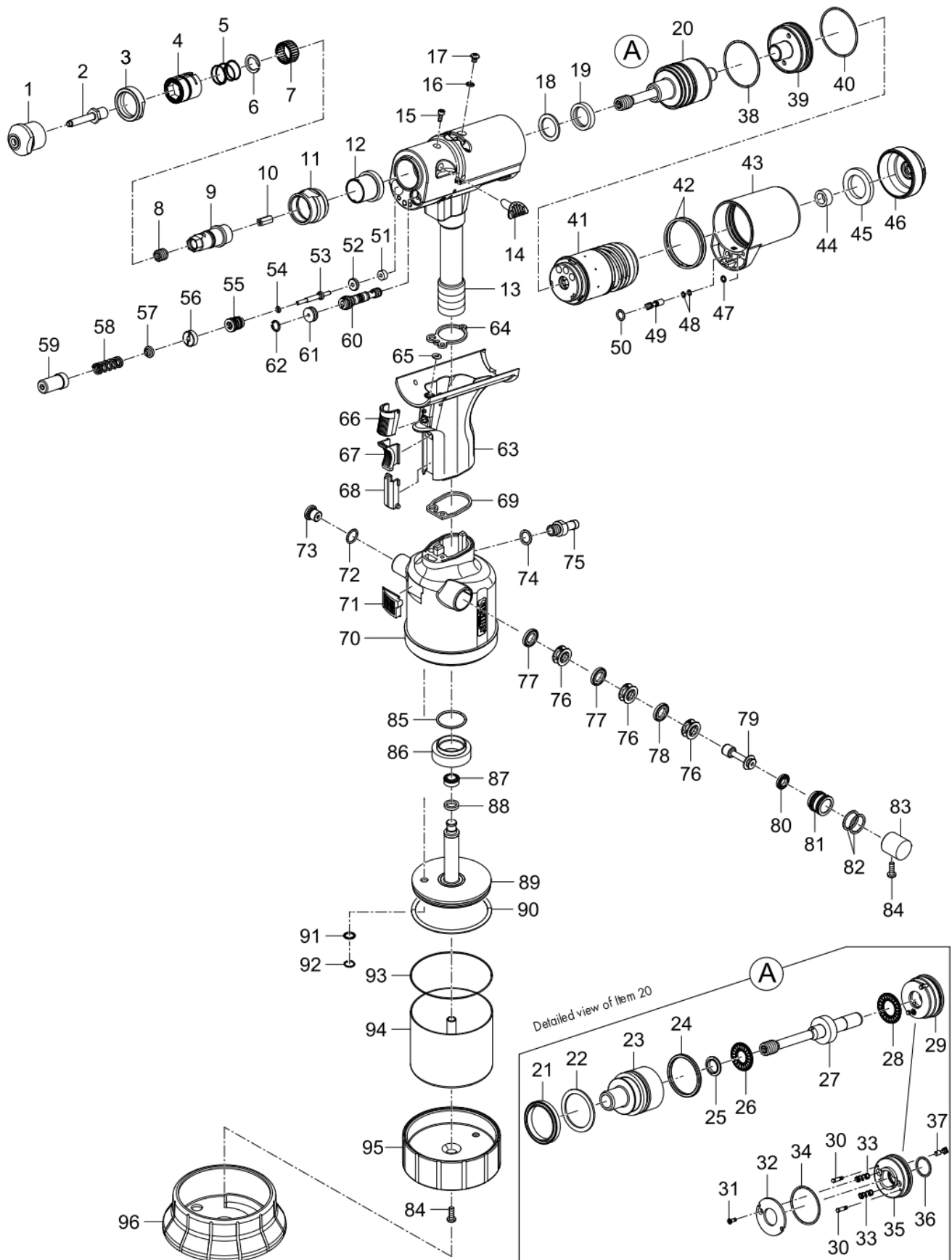

Hydro-pneumatic blind rivet nut setting tools

FireFox® 1 F

Spare part no.	Article no.	Designation	
1 •	143 6218	Nosepiece M 3	
	143 6219	Nosepiece M 4	
	143 6220	Nosepiece M 5	
	143 6221	Nosepiece M 6	
	143 6222	Nosepiece M 8	
	143 6223	Nosepiece M 10	
	143 6224	Nosepiece M 12	
	143 6256	Nosepiece 6-32 UNC	
	143 6257	Nosepiece 8-32 UNC	
	145 8113	Nosepiece 10-24 UNC	
	143 6258	Nosepiece 10-32 UNF	
	143 6259	Nosepiece 1/4"-20 UNC	
	143 6260	Nosepiece 5/16"-18 UNC	
	143 6261	Nosepiece 3/8"-16 UNC	
	2	143 6211	Threaded mandrel M 3
		143 6212	Threaded mandrel M 4
143 6213		Threaded mandrel M 5	
143 6214		Threaded mandrel M 6	
143 6215		Threaded mandrel M 8	
143 6216		Threaded mandrel M 10	
143 6217		Threaded mandrel M 12	
143 6249		Threaded mandrel 6-32 UNC	
143 6250		Threaded mandrel 8-32 UNC	
143 6251		Threaded mandrel 10-24 UNC	
143 6252		Threaded mandrel 10-32 UNF	
143 6253		Threaded mandrel 1/4"-20 UNC	
143 6254		Threaded mandrel 5/16"-18 UNC	
143 6255		Threaded mandrel 3/8"-16 UNC	
3		143 6193	Locking ring
4		145 8123	Slider
5	143 6247	Compression spring	
6	144 6189	Snap ring	
7	144 6190	Needle ring	
8	144 6187	Stud bolt	
9	143 6181	Driving pin	
10	143 6390	Hexagonal rod	
11	143 6393	Steel head sleeve 1	
12	143 6391	Stop sleeve	
13	145 8200	Tool head 1 assembled	
14	144 6204	Cap	
15	144 5427	Allen screw	
16	143 5612	Sealing ring M4	
17	144 6013	Oil screw plug	
18	143 6230	Supporting ring	
19	143 6234	Rod seal	
20	145 8201	Draw bar 1, complete	
21	143 6227	Piston seal	
22	143 6229	Supporting ring	
23	143 6204	Draw bar	
24	143 6231	Seal	
25	143 5236	Seal kit	
26	144 6191	Axial needle bearing	
27	145 1110	Tie anchor 1, complete	
28	144 5794	Axial needle bearing	
29	145 8125	Closure complete	
30	143 6183	Plug bolt	
31	144 6188	Screw	
32	143 6205	Washer	
33	143 6293	Spring	
34	143 6238	Closure	
35	143 6197	Closure	
36	143 6239	O-ring	
37	145 8124	Valve key 4 complete	

Spare part no.	Article no.	Designation
38	143 6236	O-ring
39	143 6198	End cap
40	143 6237	O-ring
41	143 6168	Air motor complete
42	143 6243	O-ring
43	143 6170	Adapter
44	143 6173	Absorber disc 1
45	143 6174	Absorber disc 2
46	143 6175	Noise suppressor cover
47	143 6242	O-ring
48	143 6291	O-ring
49	143 6292	Valve key 5
50	143 5519	O-ring
51	143 6233	Rod seal
52	143 6176	Pressure disc
53	143 6177	Plunger
54	143 5644	O-ring
55	145 8127	Insert complete
56	143 6190	Threaded ring
57	143 6178	Bevel washer
58	143 6374	Spring
59	145 1112	Spring compressor
60	143 6297	Distributing valve, complete
61	145 1053	Stopper, complete
62	144 5285	Snap ring
63	145 8122	Grip, complete
64	143 5472	Flat gasket 1
65	143 6241	O-ring
66	144 6025	Activation button
67	143 5642	Slider
68	143 6169	Orifice
69	143 5480	Flat gasket 2
70	145 1109	Air cylinder 1, complete
71	151 5051	Silencer complete
72	143 5484	O-ring
73	145 7750	Safety valve, complete
74	144 6030	Sealing ring
75	143 5667	Connecting nipple
76	143 5648	Spacer cage
77	143 5647	Rod seal
78	143 6248	Washer
79	143 6187	Control piston
80	143 5675	Piston seal
81	143 5652	Piston housing
82	143 5688	O-ring
83	144 6207	Stopper
84	144 5773	Screw
85	143 5486	O-ring
86	143 5492	Al nut
87	143 6007	Piston seal
88	143 6006	Guide ring 4
89	145 1107	Air piston 1, complete
90	143 5660	O-ring
91	143 5659	Rod seal
92	144 6027	Snap ring
93	143 5680	O-ring
94	145 1111	Cylinder 1, complete
95	143 5508	Bottom 1
96	143 6394	Rubber foot 1
	144 5294	Hydraulic oil refill bottle, 100 ml

• Wearing parts

You will find spare part kits for FireFox® 1 F on page 388.

Hydro-pneumatic blind rivet nut setting tools

Firefox® 2

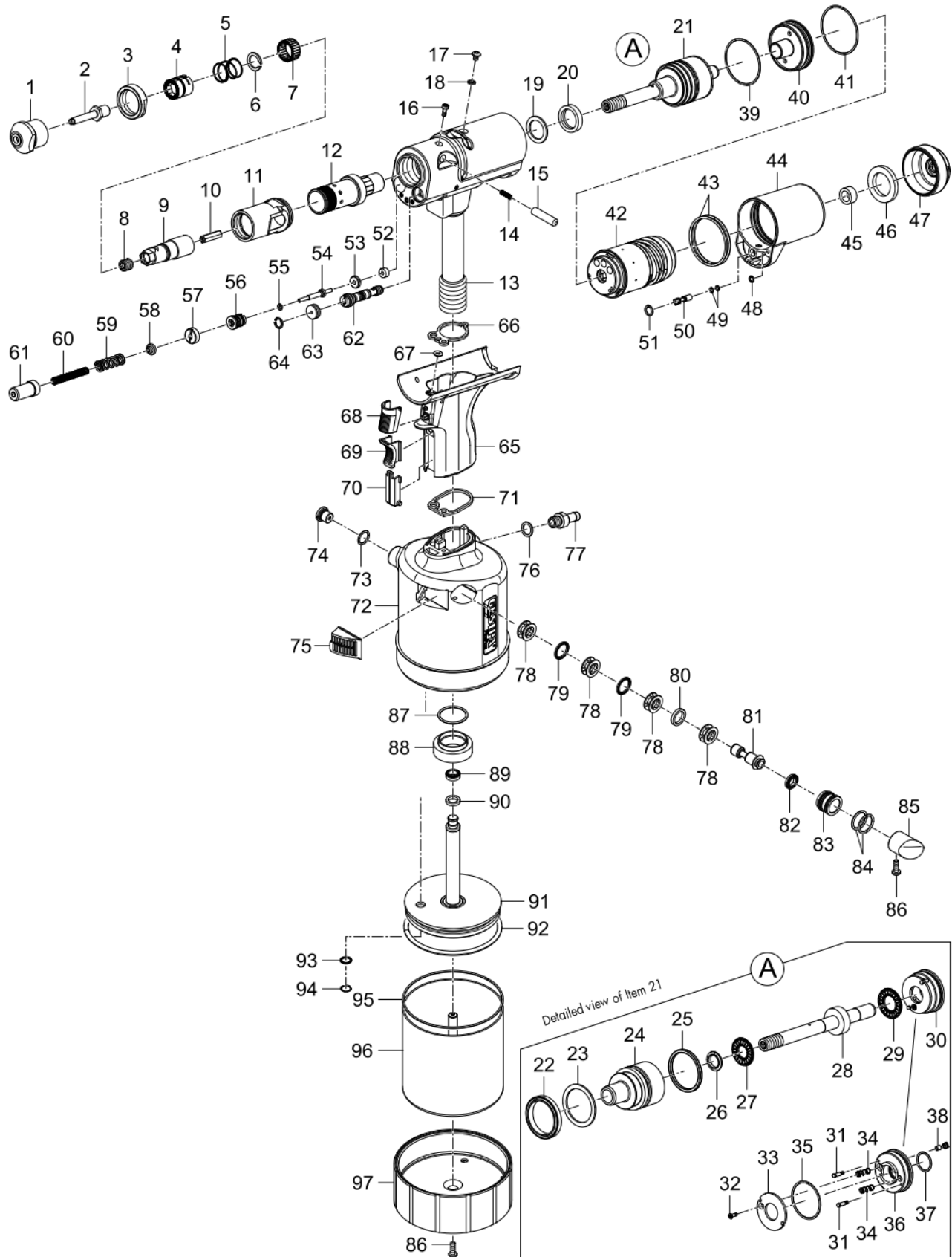

Hydro-pneumatic blind rivet nut setting tools

FireFox® 2

Spare part no.	Article no.	Designation
	143 6218	Nosepiece M 3
	143 6219	Nosepiece M 4
	143 6220	Nosepiece M 5
	143 6221	Nosepiece M 6
	143 6222	Nosepiece M 8
	143 6223	Nosepiece M 10
	143 6224	Nosepiece M 12
1 •	143 6256	Nosepiece 6-32 UNC
	143 6257	Nosepiece 8-32 UNC
	145 8113	Nosepiece 10-24 UNC
	143 6258	Nosepiece 10-32 UNF
	143 6259	Nosepiece 1/4"-20 UNC
	143 6260	Nosepiece 5/16"-18 UNC
	143 6261	Nosepiece 3/8"-16 UNC
	143 6211	Threaded mandrel M 3
	143 6212	Threaded mandrel M 4
	143 6213	Threaded mandrel M 5
	143 6214	Threaded mandrel M 6
	143 6215	Threaded mandrel M 8
	143 6216	Threaded mandrel M 10
	143 6217	Threaded mandrel M 12
2	143 6249	Threaded mandrel 6-32 UNC
	143 6250	Threaded mandrel 8-32 UNC
	143 6251	Threaded mandrel 10-24 UNC
	143 6252	Threaded mandrel 10-32 UNF
	143 6253	Threaded mandrel 1/4"-20 UNC
	143 6254	Threaded mandrel 5/16"-18 UNC
	143 6255	Threaded mandrel 3/8"-16 UNC
3	143 6193	Locking ring
4	145 8123	Slider complete
5	143 6247	Compression spring
6	144 6189	Snap ring
7	144 6190	Needle ring
8	144 6187	Stud bolt
9	143 6179	Driving pin
10	143 6201	Hexagonal rod
11	143 6192	Steel head sleeve
12	143 6200	Stroke adjuster, complete
13	145 8128	Tool head assembled
14	143 6244	Spring
15	143 6180	Locating bolt
16	144 5427	Allen screw
17	143 5612	Sealing ring M4
18	144 6013	Oil screw plug
19	143 6230	Supporting ring
20	143 6234	Rod seal
21	145 8126	Draw bar complete
22	143 6227	Piston seal
23	143 6229	Supporting ring
24	143 6204	Draw bar
25	143 6231	Seal
26	143 5236	Seal kit
27	144 6191	Axial needle bearing
28	143 6296	Tie anchor complete
29	144 5794	Axial needle bearing
30	145 8125	Closure cover, complete
31	143 6183	Stud bolt
32	144 6188	Screw
33	143 6205	Stop disc
34	143 6293	Spring
35	143 6225	O-ring
36	143 6197	Closure
37	143 6239	O-ring

Spare part no.	Article no.	Designation
38	145 8124	Valve key 4, complete
39	143 6236	O-ring
40	143 6198	End closure
41	143 6237	O-ring
42	143 6168	Air motor complete
43	143 6243	O-ring
44	143 6170	Adapter
45	143 6173	Absorber disc 1
46	143 6174	Absorber disc 2
47	143 6175	Noise suppressor cover
48	143 6242	O-ring
49	143 6291	O-ring
50	143 6292	Valve key 5
51	143 5519	O-ring
52	143 6233	Rod seal
53	143 6176	Pressure disc
54	143 6177	Plunger
55	143 5644	O-ring
56	145 8127	Insert complete
57	143 6190	Threaded ring
58	143 6178	Bevel washer
59	144 6192	Compression spring
60	143 6245	Compression spring
61	143 6191	Spring compressor complete
62	143 6297	Distributing valve complete
63	145 1053	Stopper complete
64	144 5285	Snap ring
65	145 8122	Grip, complete
66	143 5472	Flat gasket 1
67	143 6241	O-ring
68	144 6025	Activation button
69	143 5642	Slider
70	143 6169	Orifice
71	143 5480	Flat gasket 2
72	145 8118	Air cylinder 2, complete
73	143 5484	O-ring
74	145 7750	Pressure relief valve, complete
75	145 7862	Silencer complete
76	144 6030	Sealing ring
77	143 5667	Hose fitting
78	143 5648	Spacer cage
79	143 5647	Airzet rod seal
80	143 6248	Washer
81	143 6187	Rod seal
82	143 5675	Lip ring
83	143 5652	Piston housing
84	143 5688	O-ring
85	144 6075	Stopper
86	144 5773	Housing screw short
87	143 5486	O-ring
88	143 5492	Alu nut
89	143 6226	Piston seal
90	143 6235	Guide ring
91	145 8116	Air piston 2, complete
92	143 5834	O-ring
93	143 5635	Airzet rod seal
94	144 6082	V-profile ring JV15
95	143 5839	O-ring
96	145 8114	Cylinder 2, complete
97	143 5761	Bottom
	144 5294	Hydraulic oil refill bottle, 100 ml

• Wearing parts

You will find spare part kits for FireFox® 2 on page 388.

Hydro-pneumatic blind rivet nut setting tools

FireFox® 2 F / FireFox® 2 F L

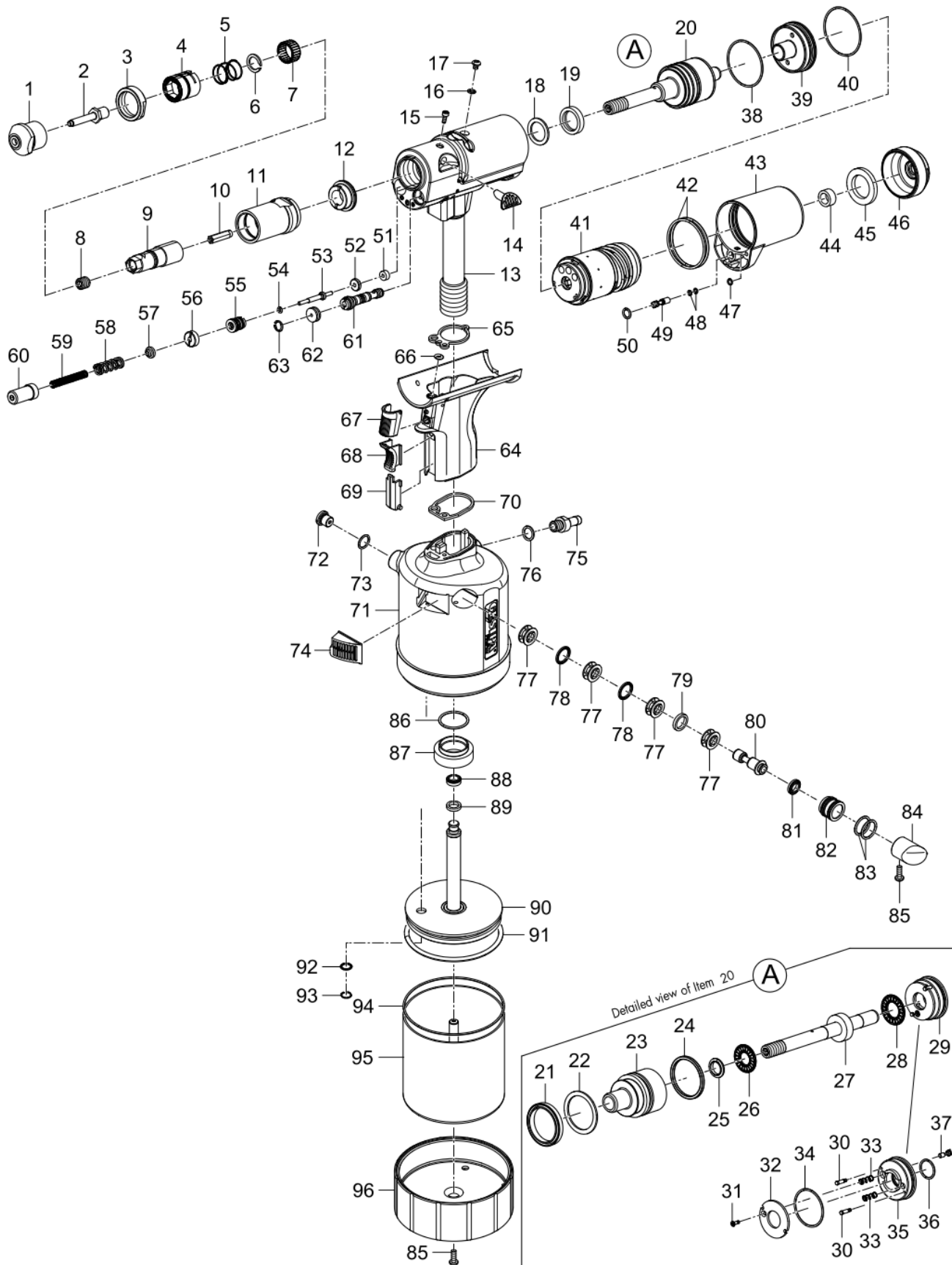

Hydro-pneumatic blind rivet nut setting tools

FireFox® 2 F / FireFox® 2 F L

Spare part no.	Article no.	Designation
	143 6218	Nosepiece M 3
	143 6219	Nosepiece M 4
	143 6220	Nosepiece M 5
	143 6221	Nosepiece M 6
	143 6222	Nosepiece M 8
	143 6223	Nosepiece M 10
1 •	143 6224	Nosepiece M 12
	143 6256	Nosepiece 6-32 UNC
	143 6257	Nosepiece 8-32 UNC
	145 8113	Nosepiece 10-24 UNC
	143 6258	Nosepiece 10-32 UNF
	143 6259	Nosepiece 1/4"-20 UNC
	143 6260	Nosepiece 5/16"-18 UNC
	143 6261	Nosepiece 3/8"-16 UNC
	143 6211	Threaded mandrel M 3
	143 6212	Threaded mandrel M 4
	143 6213	Threaded mandrel M 5
	143 6214	Threaded mandrel M 6
	143 6215	Threaded mandrel M 8
	143 6216	Threaded mandrel M 10
2	143 6217	Threaded mandrel M 12
	143 6249	Threaded mandrel 6-32 UNC
	143 6250	Threaded mandrel 8-32 UNC
	143 6251	Threaded mandrel 10-24 UNC
	143 6252	Threaded mandrel 10-32 UNF
	143 6253	Threaded mandrel 1/4"-20 UNC
	143 6254	Threaded mandrel 5/16"-18 UNC
	143 6255	Threaded mandrel 3/8"-16 UNC
3	143 6193	Locking ring
4	145 8123	Slider complete
5	143 6247	Compression spring
6	144 6189	Snap ring
7	144 6190	Needle ring
8	144 6187	Stud bolt
9	143 6179	Driving pin
10	143 6201	Hexagonal rod
11	143 6384	Steel head sleeve
12	143 6385	Sleeve
13	145 8128	Tool head assembled
14	144 6204	Cap
15	144 5427	Allen screw
16	143 5612	Sealing ring M4
17	144 6013	Oil screw plug
18	143 6230	Supporting ring
19	143 6234	Rod seal
20	145 8126	Draw bar complete
21	143 6227	Piston seal
22	143 6229	Supporting ring
23	143 6204	Draw bar
24	143 6231	Seal
25	143 5236	Seal kit
26	144 6191	Axial needle bearing
27	143 6296	Tie anchor complete
28	144 5794	Axial needle bearing
29	145 8125	Closure cover, complete
30	143 6183	Stud bolt
31	144 6188	Screw
32	143 6205	Stop disc
33	143 6293	Spring
34	143 6238	O-ring
35	143 6197	Closure
36	143 6239	O-ring

Spare part no.	Article no.	Designation
37	145 8124	Valve key 4, complete
38	143 6236	O-ring
39	143 6198	End closure
40	143 6237	O-ring
41	143 6168	Air motor complete
42	143 6243	O-ring
43	143 6170	Adapter
44	143 6173	Absorber disc 1
45	143 6174	Absorber disc 2
46	143 6175	Noise suppressor cover
47	143 6242	O-ring
48	143 6291	O-ring
49	143 6292	Valve key 5
50	143 5519	O-ring
51	143 6233	Rod seal
52	143 6176	Pressure disc
53	143 6177	Plunger
54	143 5644	O-ring
55	145 8127	Insert complete
56	143 6190	Threaded ring
57	143 6178	Bevel washer
58	144 6192	Compression spring
59	143 6245	Compression spring
60	145 1093	Spring compressor complete
61	143 6297	Distributing valve complete
62	145 1053	Stopper complete
63	144 5285	Snap ring
64	145 8122	Grip, complete
65	143 5472	Flat gasket 1
66	143 6241	O-ring
67	144 6025	Activation button
68	143 5642	Slider
69	143 6169	Orifice
70	143 5480	Flat gasket 2
71	145 8118	Air cylinder 2, complete
72	143 5484	O-ring
73	145 7750	Pressure relief valve, complete
74	145 7862	Silencer complete
75	144 6030	Sealing ring
76	143 5667	Hose fitting
77	143 5648	Spacer cage
78	143 5647	Airzet rod seal
79	143 6248	Washer
80	143 6187	Rod seal
81	143 5675	Lip ring
82	143 5652	Piston housing
83	143 5688	O-ring
84	144 6075	Stopper
85	144 5773	Housing screw short
86	143 5486	O-ring
87	143 5492	Alu nut
88	143 6226	Piston seal
89	143 6235	Guide ring
90	145 8116	Air piston 2, complete
91	143 5834	O-ring
92	143 5635	Airzet rod seal
93	144 6082	V-profile ring JV15
94	143 5839	O-ring
95	145 8114	Cylinder 2, complete
96	143 5761	Bottom
	144 5294	Hydraulic oil refill bottle, 100 ml

• Wearing parts

You will find spare part kits for FireFox® 2 F and FireFox® 2 F L on page 388.

Hydro-pneumatic blind rivet nut setting tools

FireFox® 1 F Axial eco

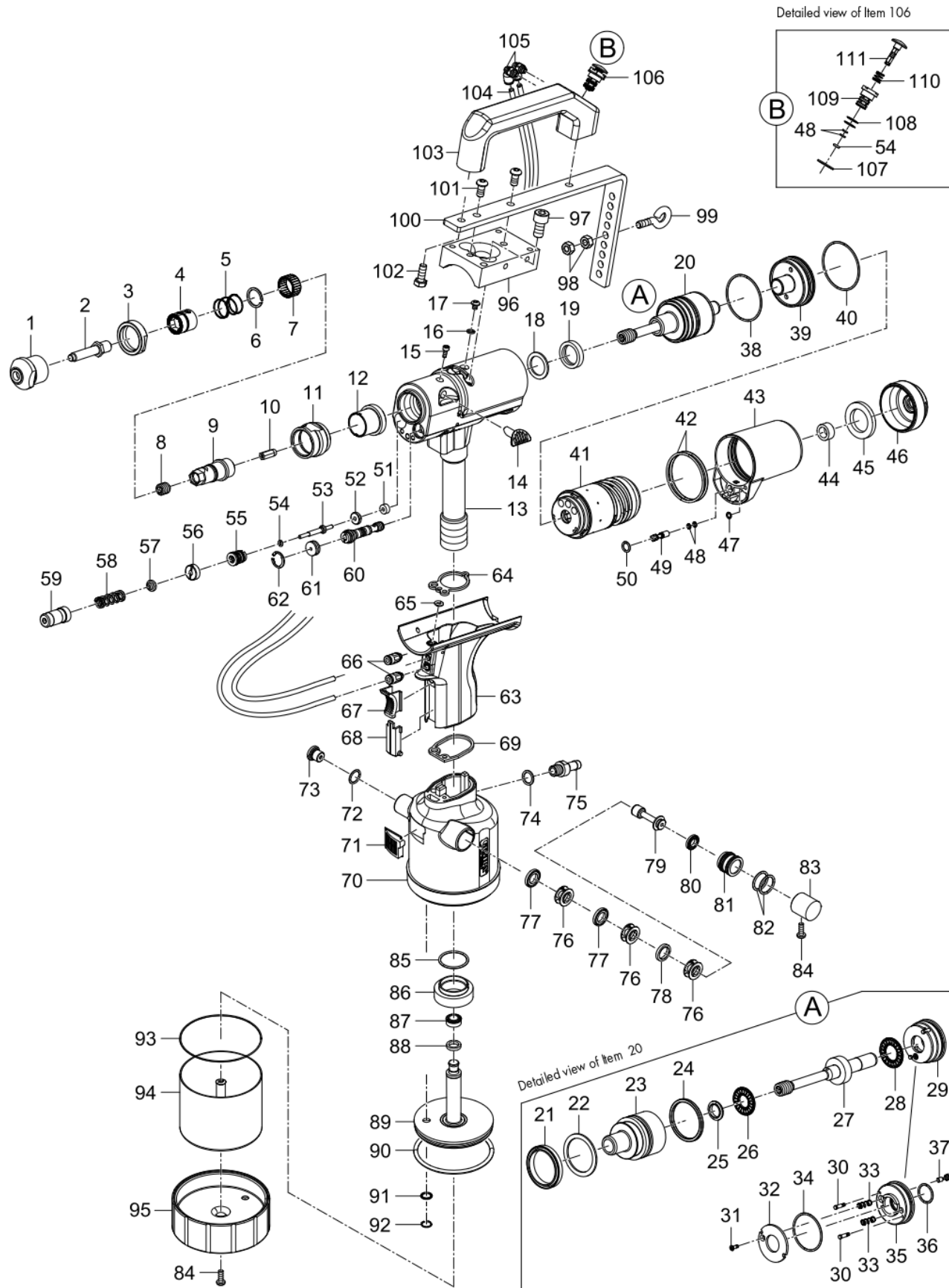

Hydro-pneumatic blind rivet nut setting tools

FireFox® 1 F Axial eco

Spare part no.	Article no.	Designation
	143 6218	Nosepiece M 3
	143 6219	Nosepiece M 4
	143 6220	Nosepiece M 5
	143 6221	Nosepiece M 6
	143 6222	Nosepiece M 8
	143 6223	Nosepiece M 10
	143 6224	Nosepiece M 12
	143 6256	Nosepiece 6-32 UNC
	143 6257	Nosepiece 8-32 UNC
	145 8113	Nosepiece 10-24 UNC
	143 6258	Nosepiece 10-32 UNF
	143 6259	Nosepiece 1/4"-20 UNC
	143 6260	Nosepiece 5/16"-18 UNC
	143 6261	Nosepiece 3/8"-16 UNC
	143 6211	Threaded mandrel M 3
	143 6212	Threaded mandrel M 4
	143 6213	Threaded mandrel M 5
	143 6214	Threaded mandrel M 6
	143 6215	Threaded mandrel M 8
	143 6216	Threaded mandrel M 10
	143 6217	Threaded mandrel M 12
	143 6249	Threaded mandrel 6-32 UNC
	143 6250	Threaded mandrel 8-32 UNC
	143 6251	Threaded mandrel 10-24 UNC
	143 6252	Threaded mandrel 10-32 UNF
	143 6253	Threaded mandrel 1/4"-20 UNC
	143 6254	Threaded mandrel 5/16"-18 UNC
	143 6255	Threaded mandrel 3/8"-16 UNC
3	143 6193	Locking ring
4	145 8123	Slider complete
5	143 6247	Compression spring
6	144 6189	Snap ring
7	144 6190	Needle ring
8	144 6187	Stud bolt
9	143 6392	Driver
10	143 6390	Hexagonal rod
11	143 6393	Steel head sleeve 1
12	143 6391	Stop sleeve
13	146 4418	Tool head 1 complete
14	144 6204	Cap piece
15	144 5427	Allen screw
16	143 5612	Sealing ring
17	144 6013	Screw
18	143 6230	Supporting ring
19	143 6234	Rod seal
20	145 8201	Draw bar complete
21	143 6227	Piston seal
22	143 6229	Supporting ring
23	143 6204	Draw bar
24	143 6231	Seal
25	143 5236	Seal kit
26	144 6191	Axial needle bearing
27	145 1110	Draw bar complete
28	144 5794	Axial needle bearing
29	145 8125	Closure
30	143 6183	Stud bolt
31	144 6188	Screw
32	143 6205	Stop disc
33	143 6293	Spring
34	143 6238	O-ring
35	143 6197	Closure
36	143 6239	O-ring
37	145 8124	Valve key
38	143 6236	O-ring
39	143 6198	End cap
40	143 6237	O-ring
41	143 6168	Air motor
42	143 6243	O-ring
43	143 6170	Adapter
44	143 6173	Absorber disc 1
45	143 6174	Absorber disc 2
46	143 6175	Closure

Spare part no.	Article no.	Designation
47	143 6242	O-ring
48	143 6291	O-ring
49	143 6292	Valve key
50	143 5519	O-ring
51	143 6233	Rod seal
52	143 6176	Washer
53	143 6177	Plunger
54	143 5644	O-ring
55	145 8127	Insert
56	143 6190	Threaded ring
57	143 6178	Bevel washer
58	143 6374	Spring
59	145 1112	Spring compressor complete
60	143 6297	Distributing valve
61	145 1053	Stopper
62	144 5285	Snap ring
63	145 1085	Grip complete
64	143 5472	Flat gasket
65	143 6241	O-ring
66	144 5718	Screw connection
67	143 5642	Slider
68	143 6169	Orifice
69	143 5480	Flat gasket
70	145 1109	Air cylinder 1 complete
71	151 5051	Silencer complete
72	143 5484	O-ring
73	145 7750	Pressure relief valve
74	144 6030	Sealing ring
75	143 5667	Connecting nipple
76	143 5648	Spacer cage
77	143 5647	Rod seal
78	143 6248	Washer
79	143 6187	Rod seal
80	143 5675	Piston seal
81	143 5652	Piston housing
82	143 5688	O-ring
83	144 6207	Stopper
84	144 5773	Housing screw, short
85	143 5486	O-ring
86	143 5492	Al nut
87	143 6007	Piston seal
88	143 6006	Guide ring
89	145 1107	Air piston complete
90	143 5660	O-ring
91	143 5659	Rod seal
92	144 6027	Snap ring
93	143 5680	O-ring
94	145 1111	Cylinder
95	143 5508	Bottom
96	143 6362	Hanger
97	144 6201	Cylinder head screw
98	144 5262	Nut
99	144 5342	Screw
100	143 6376	Hanger
101	144 6087	Fillister head screw
102	144 6208	Hexagon head screw
103	143 6380	Grip
104	144 5584	Tube*
105	144 5586	Screw connection
106	146 4420	Valve complete
107	144 5804	Washer
108	143 4148	O-ring
109	143 6378	Valve seat
110	143 6379	Spring
111	143 6377	Valve
	144 5294	Hydraulic oil refill bottle, 100 ml

• Wearing parts

* The length required must always be specified on the order; the article numbers always refers to the price per metre.

Hydro-pneumatic blind rivet nut setting tools

FireFox® 2 F Axial eco

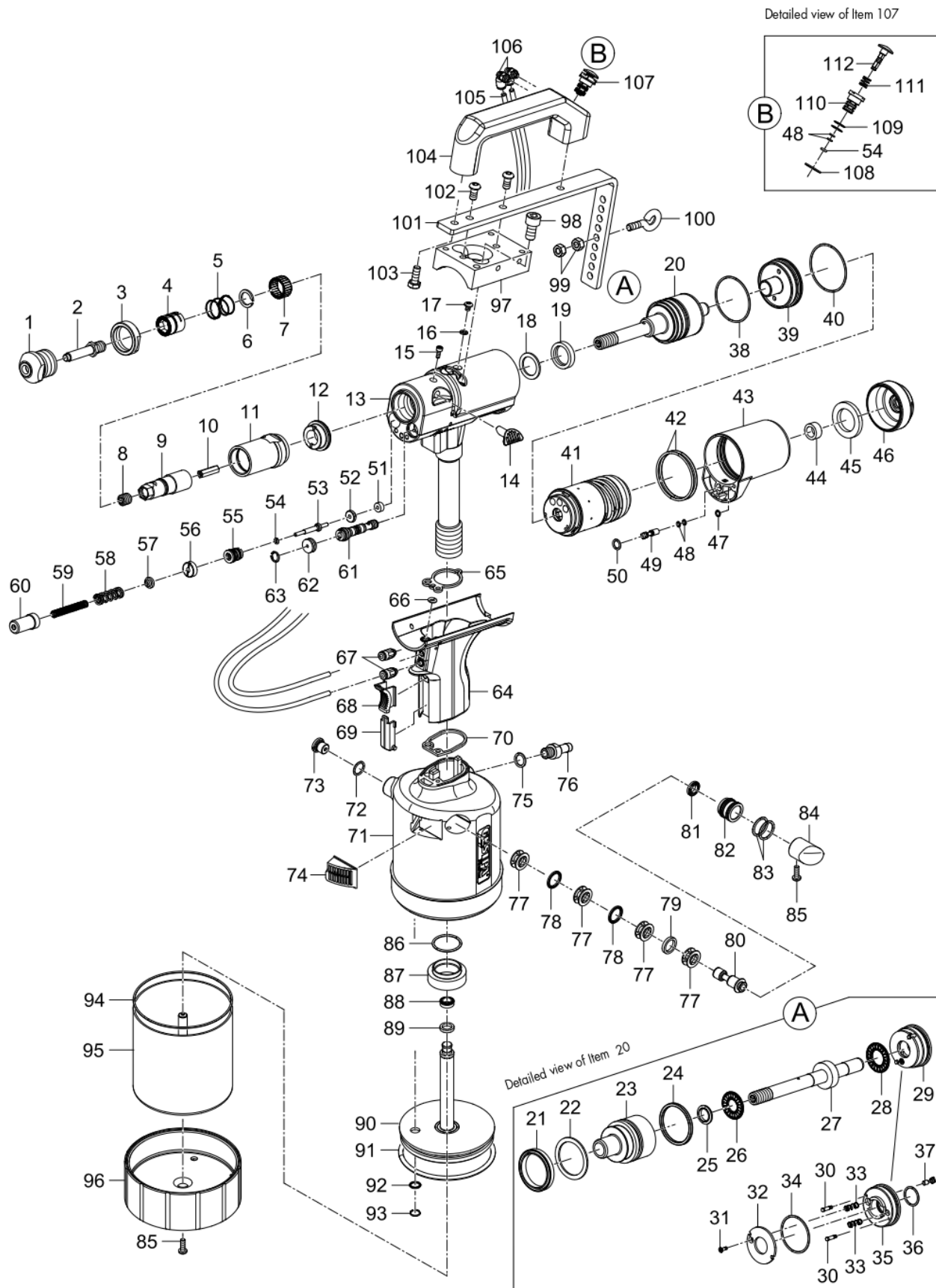

Hydro-pneumatic blind rivet nut setting tools

FireFox® 2 F Axial eco

Spare part no.	Article no.	Designation	
1 •	143 6218	Nosepiece M 3	
	143 6219	Nosepiece M 4	
	143 6220	Nosepiece M 5	
	143 6221	Nosepiece M 6	
	143 6222	Nosepiece M 8	
	143 6223	Nosepiece M 10	
	143 6224	Nosepiece M 12	
	143 6256	Nosepiece 6-32 UNC	
	143 6257	Nosepiece 8-32 UNC	
	145 8113	Nosepiece 10-24 UNC	
	143 6258	Nosepiece 10-32 UNF	
	143 6259	Nosepiece 1/4"-20 UNC	
	143 6260	Nosepiece 5/16"-18 UNC	
	143 6261	Nosepiece 3/8"-16 UNC	
	143 6211	Threaded mandrel M 3	
	143 6212	Threaded mandrel M 4	
	143 6213	Threaded mandrel M 5	
143 6214	Threaded mandrel M 6		
143 6215	Threaded mandrel M 8		
143 6216	Threaded mandrel M 10		
143 6217	Threaded mandrel M 12		
2	143 6249	Threaded mandrel 6-32 UNC	
	143 6250	Threaded mandrel 8-32 UNC	
	143 6251	Threaded mandrel 10-24 UNC	
	143 6252	Threaded mandrel 10-32 UNF	
	143 6253	Threaded mandrel 1/4"-20 UNC	
	143 6254	Threaded mandrel 5/16"-18 UNC	
	143 6255	Threaded mandrel 3/8"-16 UNC	
	3	143 6193	Locking ring
	4	145 8123	Slider complete
	5	143 6247	Compression spring
	6	144 6189	Snap ring
	7	144 6190	Needle ring
	8	144 6187	Stud bolt
9	143 6179	Driving pin	
10	143 6201	Hexagonal rod	
11	143 6384	Steel head sleeve	
12	143 6385	Sleeve	
13	145 1095	Tool head complete	
14	144 6204	Cap piece	
15	144 5427	Allen screw	
16	143 5612	Sealing ring	
17	144 6013	Screw	
18	143 6230	Supporting ring	
19	143 6234	Rod seal	
20	145 8126	Draw bar complete	
21	143 6227	Piston seal	
22	143 6229	Supporting ring	
23	143 6204	Draw bar	
24	143 6231	Seal	
25	143 5236	Seal kit	
26	144 6191	Axial needle bearing	
27	143 6296	Tie anchor	
28	144 5794	Axial needle bearing	
29	145 8125	Closure	
30	143 6183	Stud bolt	
31	144 6188	Screw	
32	143 6205	Stop disc	
33	143 6293	Spring	
34	143 6238	O-ring	
35	143 6197	Closure	
36	143 6239	O-ring	
37	145 8124	Valve key	
38	143 6236	O-ring	
39	143 6198	End cap	
40	143 6237	O-ring	
41	143 6168	Air motor	
42	143 6243	O-ring	
43	143 6170	Adapter	
44	143 6173	Absorber disc 1	
45	143 6174	Absorber disc 2	
46	143 6175	Closure	

Spare part no.	Article no.	Designation
47	143 6242	O-ring
48	143 6291	O-ring
49	143 6292	Valve key
50	143 5519	O-ring
51	143 6233	Rod seal
52	143 6176	Washer
53	143 6177	Plunger
54	143 5644	O-ring
55	145 8127	Insert
56	143 6190	Threaded ring
57	143 6178	Bevel washer
58	144 6192	Compression spring
59	143 6245	Compression spring
60	145 1093	Spring compressor complete
61	143 6297	Distributing valve
62	145 1053	Stopper
63	144 5285	Snap ring
64	145 1085	Grip complete
65	143 5472	Flat gasket
66	143 6241	O-ring
67	144 5718	Screw connection
68	143 5642	Slider
69	143 6169	Orifice
70	143 5480	Flat gasket
71	145 8118	Air cylinder
72	143 5484	O-ring
73	145 7750	Pressure relief valve
74	145 7862	Silencer
75	144 6030	Sealing ring
76	143 5667	Connecting nipple
77	143 5648	Spacer cage
78	143 5647	Rod seal
79	143 6248	Washer
80	143 6187	Rod seal
81	143 5675	Piston seal
82	143 5652	Piston housing
83	143 5688	O-ring
84	144 6075	Stopper
85	144 5773	Housing screw, short
86	143 5486	O-ring
87	143 5492	Al nut
88	143 6226	Piston seal
89	143 6235	Guide ring
90	145 8116	Air piston complete
91	143 5834	O-ring
92	143 5635	Airezl rod seal
93	144 6082	Snap ring
94	143 5839	O-ring
95	145 8114	Cylinder
96	143 5761	Bottom
97	143 6362	Hanger
98	144 6201	Cylinder head screw
99	144 5262	Nut
100	144 5342	Screw
101	143 6376	Hanger
102	144 6087	Fillister head screw
103	144 6208	Hexagon head screw
104	143 6380	Grip
105	144 5584	Tube*
106	144 5586	Screw connection
107	146 4420	Valve complete
108	144 5804	Washer
109	143 4148	O-ring
110	143 6378	Valve seat
111	143 6379	Spring
112	143 6377	Valve
	144 5294	Hydraulic oil refill bottle, 100 ml

• Wearing parts

* The length required must always be specified on the order; the article numbers always refers to the price per metre.

Hydro-pneumatic blind rivet nut setting tools

Repair tools for FireFox® 1 F - 2

Article no. 145 8130

Spare part no.	Article no.	Designation
1	143 5672*	Allen key
2	143 6306	Allen key for end cap
3	144 6031*	Turning tool for threaded ring
4	143 5674*	Slot wrench
5	143 6308	Clamp element for FireFox tool head
6	143 6304	Extraction tool
7	143 6311	Insertion tool for bit
8	143 6262	Insertion tool for seal
9	143 6307	Assembly device

*These tools are also suitable for TAURUS® 1 - 4

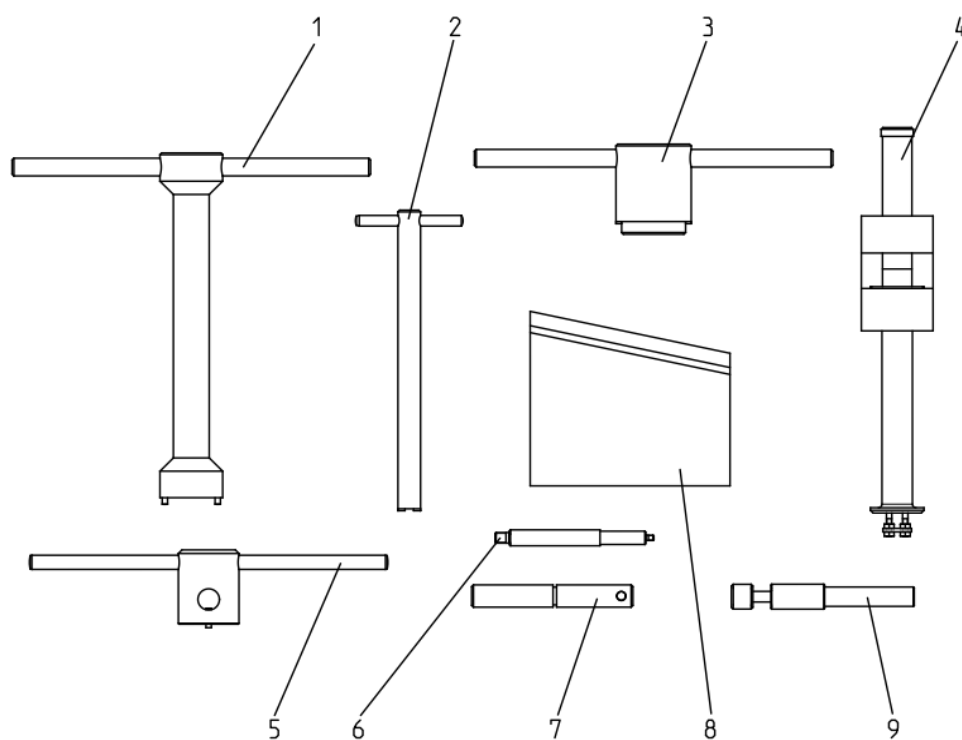

Hydro-pneumatic blind rivet nut setting tools

GBM 95 – tool no longer available

Spare part no.	Article no.	Designation
1	143 5213	Nosepiece M3
	143 5214	Nosepiece M4 and 8-32"
	143 5215	Nosepiece M5 and 10-32"
	143 5216	Nosepiece M6
	143 5217	Nosepiece M8 and 5/16-18"
	143 5218	Nosepiece M10 and 3/8-16"
	143 5148	Nosepiece 1/4-20"
2	143 5207	Threaded mandrel M3
	143 5208	Threaded mandrel M4
	143 5209	Threaded mandrel M5
	143 5210	Threaded mandrel M6
	143 5211	Threaded mandrel M8
	143 5212	Threaded mandrel M10
	143 5149	Threaded mandrel 8-32"
	143 5143	Threaded mandrel 10-32"
	143 5144	Threaded mandrel 1/4-20"
	143 5150	Threaded mandrel 5/16-18"
143 5145	Threaded mandrel 3/8-16"	
3	143 5185	Locking nut
4	143 5220	Sleeve
5	145 7574	Thrust bearing, complete
6	143 4232	Hand protection
7	145 7560	Tool head
8	145 6754	Replenishing screw complete

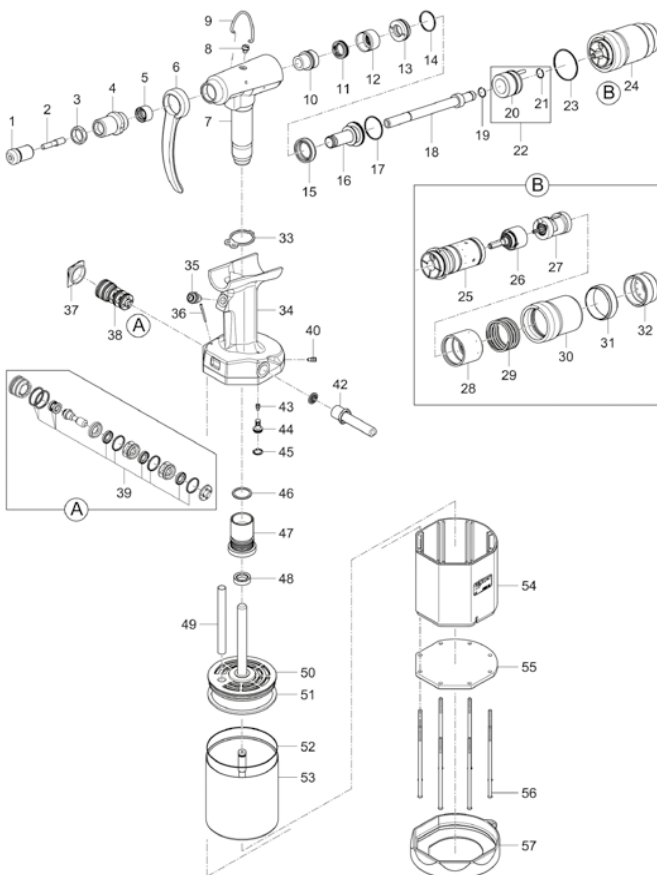

Spare part no.	Article no.	Designation
9	144 5265	Suspension bracket
10	145 7551	Sealing ring mount complete
11	145 6749	Annular piston complete
12	145 7575	Cylinder sleeve complete
13	145 6752	Casing ring complete
14	143 4227	O-ring
15	145 6757	Groove ring with supporting ring
16	145 7572	Pull piston complete
17	143 4226	O-ring
18	145 7571	Draw bar, complete
19	143 5237	O-ring
20	143 5236	Sealing ring kit
21	144 5823	Snap ring
22	145 7573	Resetting piston, complete
23	143 5243	O-ring
24	145 7556	Drill unit complete
25	145 7553	Motor frame, complete
26	145 7576	Planetary gearing, complete
27	145 7577	Air motor complete
28	145 7554	Valve slide complete
29	144 5813	Compression spring
30	145 7552	Valve housing, complete
31	143 5160	Knurled nut
32	143 5161	Cover
33	143 4221	Flat gasket
34	145 7563	Grip, complete
35	145 7567	Release valve, complete
36	143 4219	Bolt
37	143 4216	Silencer
38	145 6756	Distributing valve complete
39	145 6758	Set of seals for slide valve
40	143 5247	Adjusting screw
42	143 4220	Hose complete
43	144 5819	Stud bolt
44	145 7559	Valve piston,
45	144 5826	Snap ring
46	145 7555	O-ring with supporting ring
47	145 7550	Sealing ring mount complete
48	143 5179	Rod seal
49	143 4217	Channel tube
50	145 7549	Air piston complete
51	143 5201	O-ring
52	143 4224	O-ring
53	145 7557	Cylinder complete
54	143 5204	Casing
55	143 4236	Bottom
56	144 5292	Countersunk screw
57	143 4237	Rubber base
	144 5293	Ball Allen key
	144 5294	Hydraulic oil refill bottle
	146 2909	Open-ended wrench
	144 5809	Allen key
	144 5810	Hooked wrench
	143 5131	Assembly rod
	143 4311	Universal wrench MSU

• Wearing parts

You will find spare part kits for GBM 95 on page 389.

Spare part kits

The spare part kits contain carefully composed sets with exactly the parts that you need for your maintenance or repair.

TAURUS® 1-4

Spare part kit: 145 7720 - Grip seal set for TAURUS® 1-4

Spare part no.	Article no.	Designation
37	143 5472	Flat gasket 1
43	143 5480	Flat gasket 2
60	143 5486	O-ring

Spare part kit: 145 7721 - Lock activator seal set for TAURUS® 1-4

Spare part no.	Article no.	Designation
19	143 5632	Piston seal
20	143 5488	Supporting ring
21	143 5485	Piston seal

Spare part kit: 145 7723 - Control piston seal set for TAURUS® 2-4

Spare part no.	Article no.	Designation
52	143 5648	Spacer cage (4x)
53	143 5647	Rod seal (3x)
54	143 5651	Control piston
55	143 5675	Piston seal
56	143 5652	Piston housing
57	143 5688	O-ring (2x)

TAURUS® 2-4

Spare part kit: 145 7853 - Mandrel retainer set for TAURUS® 2-4

Spare part no.	Article no.	Designation
31	144 6028	Retaining spring
32	143 5664	Retainer
33	143 5663	Adapter
34	143 5842	Lock washer
35	143 5766	Connecting piece nut 2/3

TAURUS® 1

Spare part kit: 145 7719 - Air piston seal set for TAURUS® 1

Spare part no.	Article no.	Designation
62	143 5658	Piston seal
63	143 5657	Guide ring 1
64	143 5656	Piston seal
66	143 5660	O-ring
67	143 5659	Rod seal
68	144 6027	Snap ring
69	143 5680	O-ring

Spare part kit: 145 7722 - Control piston seal set for TAURUS® 1

Spare part no.	Article no.	Designation
52	143 5648	Spacer cage (3x)
53	143 5647	Rod seal (3x)
54	143 5651	Control piston
55	143 5675	Piston seal
56	143 5652	Piston housing
57	143 5688	O-ring (2x)

Spare part kit: 145 7724 - Mandrel retainer set for TAURUS® 1

Spare part no.	Article no.	Designation
31	144 6028	Retaining spring
32	143 5664	Retainer
33	143 5663	Adapter
34	143 5842	Lock washer
35	143 5849	Connecting piece nut 1

Spare part kits

TAURUS® 2

Spare part kit: 145 7852 - Air piston seal set for TAURUS® 2

Spare part no.	Article no.	Designation
25	143 5635	Rod seal
62	143 5841	Piston seal
63	143 5825	Guide ring 2
64	143 5670	Piston seal
66	143 5834	O-ring
68	144 6082	V-profile ring
69	143 5839	O-ring

TAURUS® 3

Spare part kit: 145 7924 - Air piston seal set for TAURUS® 3

Spare part no.	Article no.	Designation
25	143 5635	Rod seal
62	143 5841	Piston seal
63	143 5825	Guide ring 2
64	143 5670	Piston seal
66	143 5937	O-ring
68	144 6082	V-profile ring
69	143 5927	O-ring

TAURUS® 4

Spare part kit: 145 8000 - Seal set Air piston TAURUS® 4

Spare part no.	Article no.	Designation
25	143 5635	Rod seal
55	143 5675	Piston seal
62	143 6007	Piston seal
63	143 6006	Guide ring 4
66	143 5937	O-ring
68	144 6082	V-profile ring
69	143 5927	O-ring

PH 1/PH 2

Spare part kit: 145 6778 - K seal set PH1/PH2

Spare part no.	Article no.	Designation
10 •	143 4323	K seal
13 •	143 4324	K seal
15 •	143 4326	K seal

PH 2000

Spare part kit: 145 6731 - Tool head seal set for PH 2000

Spare part no.	Article no.	Designation
10	145 6749	Annular piston complete
11	145 6750	Scraper ring complete
12	145 6751	Cylinder sleeve complete
28	143 4221	Flat gasket
41	143 4223	Rod seal
17	143 4226	O-ring
14	143 4227	O-ring
39	143 4228	O-ring

Spare part kits

FireFox® 1 F - 2

Spare part kit: 145 8202 - Air piston seal set for FireFox® 1F

Spare part no.	Article no.	Designation
87	143 6007	Piston seal
93	143 5680	O-ring
88	143 6006	Guide ring 4
90	143 5660	O-ring
92	144 6027	Snap ring
91	143 5659	Rod seal

Spare part kit: 145 8179 - Distributing valve complete for FireFox® 1 F, 2, 2 F

Spare part no.			Article no.	Designation
FireFox® 1 F	FireFox® 2	FireFox® 2 F		
60	92	61	143 6297	Distributing valve complete
62	94	63	144 5285	Snap ring
61	93	62	145 1053	Stopper complete

Spare part kit: 145 7720 - Grip seal set for FireFox® 1 F, 2, 2 F

Spare part no.			Article no.	Designation
FireFox® 1 F	FireFox® 2	FireFox® 2 F		
64	66	65	143 5472	Flat gasket 1
69	71	70	143 5480	Flat gasket 2
85	89	86	143 5486	O-ring

Spare part kit: 145 8180 - Air piston seal set for FireFox® 2 - 2 F

Spare part no.		Article no.	Designation
FireFox® 2	FireFox® 2 F		
89	88	143 6226	Piston seal
95	94	143 5839	O-ring
90	89	143 6235	Guide ring
92	91	143 5834	O-ring
94	93	144 6082	V-profile ring
93	92	143 5635	Airzet Rod seal

Spare part kits

GBM 95

Spare part kit: 145 7517 - Seal set for GBM 95		
Spare part no.	Article no.	Designation
48	143 5179	Rod seal
11	145 6749	Annular piston complete
33	143 4221	Flat gasket
17	143 4226	O-ring
14	143 4227	O-ring
10	145 7551	Sealing ring mount complete
46	145 7555	O-ring with supporting ring
12	145 7575	Cylinder sleeve, complete

We reserve the right to make changes for the entire catalogue. We do not accept liability for errors or misprints.

The applicable terms and conditions of guarantee shall apply and can be viewed under following link:

www.gesipa.com/agb

Damages resulting from natural wear and tear, overloading, use of unsuitable batteries or inexpert handling will be excluded from the guarantee. Damages resulting from material or manufacturing faults will be repaired or replaced free of charge. Claims can only be accepted if the complete riveting tool is returned to the distributor or GESIPA®.

Point of sale

Clearly presented & space-saving – the GESIPA® triangular stand

The fact that the Profi Center rotates allows the GESIPA® range to be ideally presented in the smallest of spaces. Just 1.2 square metres are required for the Profi Center at the POS. The high-quality castors and the stable construction allows the position to be changed with minimal effort.

As well as the outstanding margins and free provision of the presentation stand, it is the professional and high-end appearance of the Profi Center that makes it so attractive. All GESIPA® fast turners are clearly presented in a display that promotes sales. See for yourself and impress your customers with the Profi Center from the blind rivet technology professionals.

Advantages:

- Professional goods presentation (area 1.2 m²; height 2.10 m)
- All fast turners in one place
- Presentation stand provided free
- Outstanding margin

Space-saving: the rotating triangular stand

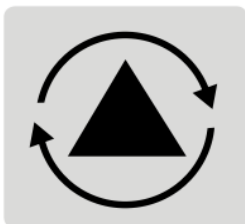

Advice and delivery time on request.



Display side 1:

DIY supplies:

Manual blind rivet setting devices and manual blind rivet nut setting devices, mini pack blind rivets and mini pack blind rivet nuts in various designs and materials

Profi Center Sales display



Display side 2:

Blind rivet technology

3 blind rivet setting devices (dummy), various manual blind rivet setting devices and various PolyGrip® blind rivet dimensions



Display side 3:

Blind rivet nut technology

Blind rivet nut setting devices (dummy), manual blind rivet nut setting devices and various blind rivet nut dimensions

Point of sale

Sales wall



The GESIPA® sales wall guarantees the highest level of attention in specialist stores.

All GESIPA® fasteners are professionally and clearly presented on a sales wall that promotes sales. Using light boxes, attention is skilfully drawn to the GESIPA® logo, which serves as an eye-catcher for the customers. The light boxes are suitable for the TEGOMETALL racking system.

Prices and additional information are available on request.

The GESIPA® sales team will be happy to advise you!

Rivet Handbook



The ideal companion for the GESIPA® „Do-it-yourself“ product range.

With GESIPA® blind rivet technology, both large and small objects in the home can be repaired in next to no time.

The Rivet Handbook explains the advantages of blind rivet technology by means of easily understandable examples. Figures illustrate the range of possible applications for rivets as well as the setting procedure using the corresponding tools.

Point of sale

In-house trade fairs

GESIPA® will gladly take part in your in-house trade show.

In the retail sector information is just as important as the products themselves. Due to the wide range of products available on the market, many products are no longer self-explanatory, and hence experience sharing and a relationship based on trust are becoming increasingly important. Establishing contacts is very important and, traditionally, this takes place at trade fairs when talking to business partners.

Just contact us and we will be happy to come to your in-house trade fair!



Information and advertising material



You will find all the available information quickly on our service portal. Besides the latest catalogue and various operating instructions, a wide range of flyers and brochures can be downloaded here:

www.gesipa.com/en/flyer-brochure

Germany

GESIPA Blindniettechnik GmbH
 Nordendstraße 13-39
 64546 Mörfelden-Walldorf
 T +49 6105 962 0
 F +49 6105 962 287
 info@gesipa.com
 www.gesipa.com

Great Britain

SFS Group Fastening
 Technology Ltd.
 Division Riveting (GESIPA)
 Dalton Lane, Keighley
 West Yorkshire BD21 4JU
 T +44 1535 212 200
 F +44 1535 212 232
 info@gesipa.co.uk
 www.gesipa.co.uk

France

SFS Group SAS
 Division Riveting (GESIPA)
 39, rue Georges Méliès
 FR-26000 VALENCE
 T +33 4 757569 21/22
 F +33 4 757569 25
 info@gesipa.fr
 www.gesipa.fr

India

Indo-Schöttle Auto Parts Pvt.Ltd.
 Division Riveting (GESIPA)
 Gat N° 378/387/389
 Village Urawade, Taluka Mulshi
 Pirangut, Dist. Pune - 412 115
 Maharashtra State, India
 T +91 20 325 400 50
 F +91 20 667 405 19
 sandeepanand@indoschoettle.com
 www.gesipa.in

Turkey

SFS intec Bağlantı Teknolojileri
 San. ve Tic. AŞ
 Division Riveting (GESIPA)
 Celal Umur Cad. No:9
 TR-35860 Torbalı/Izmir
 T +90 232 8532000
 F +90 232 8532154
 info@gesipa.com.tr
 www.gesipa.com.tr

Austria

SFS Group Austria GmbH
 Division Riveting (GESIPA)
 Biróstrasse 19, 1230 Wien
 T +43 1 6160 866 18
 F +43 1 6160 869
 office@gesipa.at
 www.gesipa.at

USA

SFS Group USA, Inc.
 Division Riveting (GESIPA)
 125 Quality Drive,
 Mocksville, NC (USA) 27028
 T + 1 336 751 1555
 F + 1 336 751 1568
 info@gesipausa.com
 www.gesipausa.com

Hungary

SFS Group Hungary Kft.
 Division Riveting (GESIPA)
 Vásártér 18
 9241 Jánossomorja
 T +36 96 517892
 F +36 96 517893
 gesipa@t-online.hu
 www.gesipa.com

China

SFS intec (China) Advanced
 Precision Parts Manufacturing
 Co., Ltd.
 瑞科 (中国) 精密紧固件制造有限公司
 No.12, Huangge East 2nd Rd,
 Auto Zone A3, Huangge Town, Nansha
 District, Guangzhou,
 P.R China 511455
 中国广州南沙区黄阁汽车城
 A3区黄阁东二路12号, 511455
 T +86 20 3906 3828
 F +86 20 3906 3821
 info@gesipa.cn
 www.gesipa.cn

Poland

GESIPA Polska Sp.z.o.o.
 Sikorskiego 5
 05-119 Legionowo
 T +48 22 7743 040
 F +48 22 7743 853
 gesipa@gesipa.com.pl
 www.gesipa.com.pl

Czech Republic

SFS Group CZ s.r.o.
 Division Riveting (GESIPA)
 Škrobárenská 482/4
 617 00 Brno-Komárov
 T +420 543 21
 F +420 543 216 049
 info@gesipa.cz
 www.gesipa.cz

Spain

SFS Group Fastening
 Technology (Iberica) S.A.U.
 Division Riveting (GESIPA)
 Pol. Txako - Edificio 3
 48480 Arrigorriaga-Vizcaya
 T +34 946712662
 F +34 946712658
 informacion@gesipa.es
 www.gesipa.es

Mexico

SFS Group Fastening Technology
 México S.A. de CV
 Division Riveting (GESIPA)
 Lateral Norte Autopista 57 México
 Querétaro KM 201 +100
 BP Conin Advance, módulos 30/32
 Col. Cumbres del Conin
 76240 El Marqués.
 Querétaro, México
 T +52 442 3251465
 martin.muhr@gesipa.com
 www.gesipa.com

1458273

PROVEN QUALITY MANAGEMENT

DIN EN ISO 9001
 ISO/TS 16949

A member



Get quote »

GESIPA®

Angic Global Solutions

1-888-872-0690

<https://www.AngicGlobal.com> Sales@AngicGlobal.com