

# DZUS

QUICK ACTING FASTENERS



Get quote 

Angic Global Solutions

1-888-872-0690

<https://www.AngicGlobal.com> [Sales@AngicGlobal.com](mailto:Sales@AngicGlobal.com)

Give Your Access Points -  
✓ Convenient Operation  
✓ Repeatable Service  
✓ Secure Performance



## INTRODUCTION

The DZUS General Catalog offers a wide and growing range of Quick-Acting Fasteners for securing access panels, covers and detachable components. Each DZUS Fastener is built to withstand repeated use, to operate reliably within its design limits, and to provide a high level of user convenience.

Our current standard product lines are briefly described, with page references, on the first three pages. The catalog section for each line has detailed descriptions, dimensions and installation procedures.

Thank you for your interest in DZUS Quick-Acting Fasteners.

*Our addresses are listed on Page 4.*

**NOTE** —The selection and installation planning of fasteners can influence the security of the fastened parts. Dzus product information and support service is intended for use only by persons with mechanical engineering qualifications sufficient to manage the responsibilities of:

1. Analyzing fastener performance in relation to the service to be met, and
2. Planning appropriate fastening locations and installations.

A18 © 1990 DZUS FASTENER CO. INC.



Get quote »

Angic Global Solutions

1-888-872-0690

<https://www.AngicGlobal.com> [Sales@AngicGlobal.com](mailto:Sales@AngicGlobal.com)

# CATALOG CONTENTS

<b>2</b>	<b>DZUS FASTENERS, VISUAL REFERENCE</b>	The Visual Reference Table can help you identify a standard DZUS Fastener you may have seen in use or have in hand.	Help with parts identification and in matching fasteners to needs is always available from our main sales office.
<b>3</b>	<b>DZUS PART NUMBER INDEX</b>	The Part Number Index gives catalog page numbers for standard current parts,	and identifies some special and obsolete parts that may be in current use.
<b>4</b>	<b>DZUS ADDRESSES</b>	The DZUS organization includes manufacturing plants in the United States, Europe and Japan, with an extensive international network of technical representa-	tives and distributors. Standard Quick-Acting Fasteners and related technical service are available wherever your facilities may be.
<b>5</b>	<b>1/4 TURN FASTENERS, GENERAL USE</b>	Standard Line 1/4 Turn Fasteners are offered in a wide range of styles and sizes. 1/4 turn studs engage receptacles and operate in about 90° rotation. They apply a predictable clamping force and provide a	detent in locked position that resists accidental opening. 1/4-turns provide convenient and reliable fastening where take-up is not required and material thickness is constant.
<b>33</b>	<b>1/4 TURN FASTENERS, RACK MOUNTED</b>	Panel Line 1/4 Turn Fasteners include a captive stud assembly and multi-hole receptacle strips. The stud cups are flared into countersunk panel holes. The recep-	tacle strips can frame out console openings and serve as supports for instruments and access panels. Mil-Spec Approved.
<b>38</b>	<b>1/4 TURN FASTENERS, AIRCRAFT PANEL</b>	Supersonic Line 1/4 Turn Fasteners provide higher strength fastening on demanding applications such as aircraft access panels. All parts are ruggedly constructed and the	receptacle is designed to limit sheet separation under tensile overload. Mil-Spec Approved.
<b>49</b>	<b>1/4 TURN FASTENERS, PLASTIC</b>	Dart Line Plastic 1/4 Turn Fasteners provide secure access fastening of lightly-loaded panels. Molded studs permit	contemporary head styling and attractive black finishes. Reliable and repeatable performance at low installed cost.
<b>54</b>	<b>1/4 TURN FASTENERS, METRIC</b>	Panex Line 1/4 Turn Fasteners feature metric parts and fast installation procedures,	well suited for commercial products produced internationally.
<b>60</b>	<b>FAST THREAD FASTENERS</b>	Universal Line Fasteners have 4-lead threads that can fully lock or release in less than 2 turns. Stud engagement spreads the notched receptacle wall	against a surrounding coil spring, for a friction lock. Locking tension remains constant over many cycles.
<b>71</b>	<b>TOGGLE LATCHES</b>	Toggle Latches provide take-up of edgemating parts in plane with the latch mounting surface. Over-center action ensures a vibration resistant closure.	Available in 3 broad ranges: spring wire links, threaded adjustable links, and one-piece segmented plastic.
<b>80</b>	<b>PAWL LATCHES</b>	Pawl Latches operate by rotating a stud, having a pawl finger radially attached to its shank. A 1/4 turn brings the pawl under a support member, and opposite rotation provides release. Some types have rigid	pawls widely-adjustable in grip range; others have self-adjusting spring pawls. Single hole mounting, no receptacles needed.
<b>89</b>	<b>PUSH TO LOCK FASTENERS</b>	Push to Lock Fasteners in this range share the simplicity of push action, at least for their closing motion. These fasteners also have in common a tolerance for sheet	thickness variation that is generally exceeded only by fasteners requiring adjustment. Each type also offers installation procedures that are fast and tool-free.
<b>96</b>	<b>SLIDE LATCHES</b>	Slide Latches consist of a base plate and sliding handle assembly which is attached to one part to be fastened, and a bush or stud, attached to the other part. The	notched handle end grips the stud with a snap action that is resistant to vibration. The latch is operable with low clearance over the handle.
<b>INSIDE BACK COVER</b>	<b>EQUIVALENT TABLES</b>	Measurement conversion tables in gauges, inch-base, and metric.	











Get quote »



Angic Global Solutions



1-888-872-0690

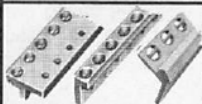

<https://www.AngicGlobal.com> [Sales@AngicGlobal.com](mailto:Sales@AngicGlobal.com)

# DZUS QUICK-ACTING FASTENERS VISUAL IDENTIFICATION

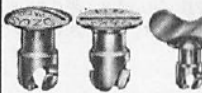

5	<b>1/4 TURN FASTENERS STANDARD LINE</b>	
8-16, 25		STUDS: SLOT, WING RECESS, RING
24		STUDS: SELF- EJECTING
9-17, 22		RECEPTACLES: RIVETED, SPRING-WIRE
9-17, 24		RECEPTACLES: WELD PLATE, FLAT
22		RECEPTACLES: WELD PLATE, 90° BEND
20		RECEPTACLES: SLIP-ON OVER EDGE
18		RECEPTACLES: CLIP-IN SQUARE HOLE
19		RECEPTACLES: SEALED PRESS-IN
21		GUIDE-PIN FASTENER, RIGID STUD



33	<b>1/4 TURN FASTENERS PANEL LINE</b>	
34		CAPTIVE STUD ASSEMBLIES: FLARED CUP
35		RECEPTACLE STRIPS: MULTI-HOLE
36		RECEPTACLES: SINGLE HOLE

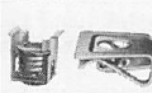





38	<b>1/4 TURN FASTENERS SUPERSONIC LINE</b>	
41-45		STUDS: SLOT, WING
42-46		RECEPTACLES: ENCLOSED, RIVETED





49	<b>1/4 TURN FASTENERS DART LINE</b>	
52-53		RECEPTACLES: PLASTIC
51		STUDS: PLASTIC ANY HEAD STYLE

54	<b>1/4 TURN FASTENERS PANEX LINE</b>	
56-58		STUDS: EDGE-CUT CAM, ANY HEAD STYLE
56-59		RECEPTACLES: SLIP-ON, SQUARE HOLE

60	<b>FAST THREADS UNIVERSAL LINE</b>	
63-67		STUDS: ANY HEAD STYLE
64-68		RECEPTACLES: RIVETED, PRESS-IN

71	<b>TOGGLE LATCHES</b>	
72-74		WIRE LINK
75-77		ADJUSTABLE LINK
78		PLASTIC: ONE PIECE SEGMENTED

80	<b>PAWL LATCHES</b>	
81		RING ROTATION ADJUSTS PAWL
82		HEAD ROTATION ADJUSTS PAWL
83		HEAD ROTATION ADJUSTS PAWL, SLOPED SPRING PAWL
84		FLUSH HANDLE: LIFT-TWIST ADJUSTS PAWL
85		<b>NEW!</b> MINI-LOW PROFILE FIXED GRIP
86		LOW PROFILE HEAD, SOLID FIXED GRIP
88		PLASTIC STUD: PUSH-ON SPRING PAWL

89	<b>PUSH ACTION FASTENERS</b>	
90-92		PUSH TO LOCK, 1/4 TURN TO OPEN, STEEL
93		PUSH TO LOCK, 1/4 TURN TO OPEN, PLASTIC
94		PUSH PANEL TO LOCK OR OPEN, CONCEALED
95		PUSH PANEL—LOCK, SLIDE BACK—OPEN

96	<b>SLIDE LATCHES</b>	
96		SLIDE HANDLE TO OPERATE

# DZUS PART NUMBER INDEX

PART NUMBER	PAGE
A3-, A4-, A5-, A6-, A7- AJ3-, AJW3- AJ4-, AJW4- AJ5-, AJW5-	* 8 10 12
AJ6-, AJW6- AJ7-, AJW7- A3½T..., AW35T... A5T..., AW5T...	14 16 41 43
A6T..., AW6T... AHJ... A0..., AOW... APJ...	45 25 25 25
APRJ... ASJ, ASJW... ASHJ... BJR3-	* 25 * 8
BJR4- BJR5- BJR6- BJR7-	10 12 14 16
DP106- DP109- DP134-9 DP137-	81 82 18 88
DP140- DP170-, DP175- EF5- EF6-	82 83 * *
EHF5- EHF6- F3-, F4-, F5-, F6-, F7- FJ3-	24 * * 8
FJ4- FJ5- FJ6- FJ7-	10 12 14 16
F35T... F5T... F6T... FO..., FOW...	41 43 45 25
GA3-, GH3, GP3 GH35 GA4-, GF4-, GH4, GP4 GA5-, GF5-, GH5, GP5	9 42 11 13
GA6-, GF6-, GH6, GP6 GA7-, GF7-, GH7 GSA..., GSF... KJ...	15 17 23 *
P325- PB35- PC35- PF35-	* * * *
PFSC35- PR35, PR35-1 PR35-X... PRA35	34 35 36 *

PART NUMBER	PAGE
PRB35 PRC35 PRF35, PRG35 PS35	36 36 * *
PS35 X 546, X 776 PVS35- R35 R5 R6	* 34 42 44
R6 RF35, RF35 X 734 RF35-5 RF5, RF5-5	46 42 42 44
RF6, RF6-5 RP3-, RP4-, RP5- S3- S4-	46 22 9 11
S5- S5A- S6- S6A-	* 13 * 15
S7- SB... SC... SD...	17 22 22 *
SL... SPS3-, 4- SQA4- SQC4-	20 19 * 18
SR3 SR35 SR4 SR5	9 42 11 13
SR6 SR7 SX510 SX518	15 17 13 15
SX519 SX520 SX523 SX551	17 9 11 42
SX560 TL100... TL110 TL200...	* 76 77 74
TL300... TL400... TL600... TL800A, G, DA, DB	75 74 * 72
TL802A, G, DA, DB TL803A, B, G, DA, DB TL806A, B, G, DA, DB TL800-5, -7, -9	72 72 72 73
TL802-2 TL900... UA3T..., UFSH3T..., UH3T... UF3T...	73 * 63 *

PART NUMBER	PAGE
UA4T..., UF4T..., UH4T... UA5T..., UF5T..., UH5T... URA3, URF3-3 URFA3, URFP3	65 67 64 64
URA4, URF4-3 URFA4, URFP4 UR5, URF5, URF5-3 U5Y100...	66 66 68 *
WA512 WA514 WA516 WA518	* 66 68 *
WA520 X159 X200- X414-	* * * 13
X441- X442- X485- X573-	15 17 11 *
X721- X735- X752- X935-	* 9 * 21
X936- X945- Y166 004-000-	21 24 64 51
004-001 THRU -006- 004-012 AND -013- 004-045 THRU -100- 004-911 THRU -915-	52 53 51 53
014-045 THRU -100- 124-045 THRU -100- 166-045 THRU -100- 200-, 201-	* 51 51 93
225- 265-, 275- 285- 290-	94 92 90 91
314-1..., 314-2... 314-3..., 324- 334-200- 334-300-	56 57 56 57
316-1..., 316-2..., 316-3 326 336-200- 336-300-	58 59 58 59
344-045 THRU -100- 404- 411- 425-	* 95 78 84
444-045 THRU -100- 461... 462 1500, 1510, 15003, 15004 2001-	51 86 85 96 *

\*INDICATES SPECIAL PART, NOT IN CATALOG.



Get quote »

# DZUS SERVICE INFORMATION

## WHERE TO CALL

**For Quotations or Order Entry:**  
Contact our main plant or the authorized stocking distributor nearest you.

**For Technical or Applications Help:**  
Contact our main plant or the technical service center shown for your area.

**MAIN PLANT AND SALES OFFICE: DZUS FASTENER CO. INC.**  
425 Union Boulevard, West Islip, NY 11795/Switchboard: 516-669-0494  
Sales Office: 516-669-6000/Telex: 71-4974043 (DZUS UI)/FAX: 516-669-0785

**DZUS F.S.C. NUMBER: 72794**

### TECHNICAL SERVICE CENTERS

(For Technical or Applications Help)

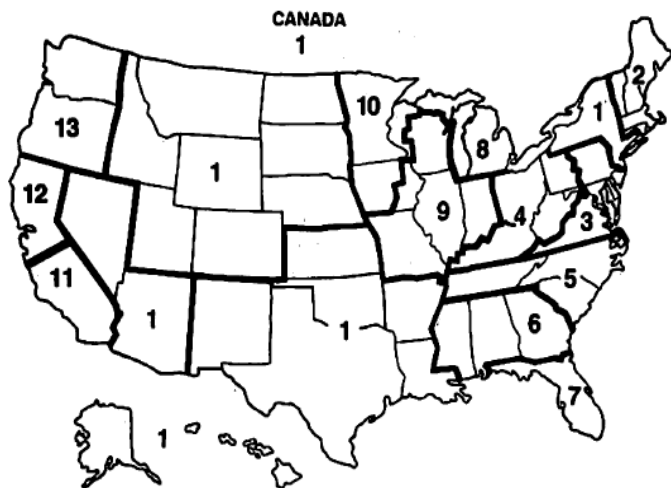

- 1. Dzus Fastener Co. Inc.**  
West Islip, NY  
516-669-0494  
FAX: 516-669-0785
- 2. G.M. Blaney Associates**  
Madison, CT  
203-245-4555
- 3. G.A. Recentio Associates**  
Doylestown PA 18901  
215-348-7577  
FAX: 215-348-8458
- 4. The Milber Co.**  
Cleveland, OH  
216-752-7528
- 5. Blair Engineering, Inc.**  
Greensboro, NC  
919-273-8200  
FAX: 919-273-8707
- 6. Blair Engineering, Inc.**  
Atlanta, GA  
404-491-8833  
FAX: 404-491-6487
- 7. Blair Engineering, Inc.**  
Fern Park, FL  
407-834-1244
- 8. J.E. Shireling Co.**  
Grand Rapids, MI  
616-957-0051  
Detroit: 313-569-5585
- 9. S.W. Anderson Co.**  
Downers Grove, IL  
708-964-2600  
FAX: 708-964-2696.
- 10. S.W. Anderson Co.**  
Eden Prairie, MN  
612-934-2700  
FAX: 612-934-2716
- 11. Dzus Fastener Co. Inc.**  
Buena Park, CA  
714-761-4142
- 12. Dzus Fastener Co. Inc.**  
Palo Alto CA 94036  
415-494-7211
- 13. Steve Brown Co. Inc.**  
Portland OR 97228  
503-293-1683  
FAX: 503-293-6009

### AUTHORIZED STOCKING DISTRIBUTORS

(For quotations or order entry)

**CALIFORNIA**  
**BARCO AVIATION, INC.**  
Los Angeles  
213-207-0481  
FAX: 213-820-6146

**ILLINOIS**  
**S.W. ANDERSON CO.**  
Downers Grove  
708-964-2600  
FAX: 708-964-2696

**MINNESOTA**  
**S.W. ANDERSON CO.**  
Eden Prairie  
612-934-2700  
FAX: 612-934-2716

**TEXAS**  
**STANDARD PARTS AND EQUIPMENT CORP.**  
Fort Worth  
817-336-2521  
FAX: 817-332-6833

**KANSAS**  
**STANDARD PARTS AND EQUIPMENT CORP.**  
Wichita  
316-522-1516  
FAX: 316-522-5680

**CANADA**  
**GOULD FASTENERS LTD.**  
Mississauga, Ontario  
416-677-8253  
FAX: 416-677-8767

### DZUS OVERSEAS ASSOCIATE COMPANIES

**UNITED KINGDOM**  
**DZUS FASTENER EUROPE, LTD.**  
Farnham, Surrey  
44-252-714422  
FAX: 44-252-712738

**GERMANY**  
**DZUS FASTENER GmbH**  
Roedermark  
49-6074-98008  
FAX: 49-6074-94257

**FRANCE**  
**DZUS FRANCE S.A.**  
LeBlanc-Mesnil  
33-1-4865-2672  
FAX: 33-1-4865-0258

**SCOTLAND**  
**JUST FASTENERS LTD.**  
Dumbarton  
44-0389-32774  
FAX: 44-0389-32111

**JAPAN**  
**JAPAN DZUS K.K.**  
Tochigi  
81-3-750-7171  
FAX: 81-3-750-2200

### DZUS OVERSEAS AGENTS

**AUSTRALIA**  
**POP FASTENERS**  
Mitcham

**BELGIUM**  
**PIRMATECH PVBA**  
Kessel-Lo

**DENMARK**  
**HARTTUNG FASTENERS A.S.**  
Herlev

**FINLAND**  
**OSAKEYHTIO S&N**  
Helsinki

**HONG KONG**  
**RICHMOND BUILDING LTD.**  
Central Hong Kong

**IRELAND**  
**THE TECHNICAL EQUIPMENT CO. LTD.**  
Dublin

**ISRAEL**  
**MANFRED GOTTESMANN AGENCIES**  
Tel-Aviv

**ITALY**  
**UVIT IL CINGOLO**  
Milan

**JAPAN**  
**JAPAN DRIVE-IT CO. LTD.**  
Tokyo

**NETHERLANDS**  
**BORSTLAP B.V.**  
Tilburg

**NEW ZEALAND**  
**J. RUSSELL HANCOCK LTD.**  
Auckland

**NORWAY**  
**SJONG FASTENERS A.S.**  
Oslo

**PORTUGAL**  
**UTEC**  
Lisbon

**SINGAPORE**  
**BESTAIR AERONAUTICAL PTE, LTD.**  
Singapore

**SOUTH AFRICA**  
**ASTRA FASTENERS PTY, LTD.**  
Denver

**SPAIN**  
**CONISA**  
Madrid

**SWEDEN**  
**AERO MATERIAL A.B.**  
Johnneshov

**SWITZERLAND**  
**JAKOB KELLER**  
Wellhausen



Get quote »

Angic Global Solutions

1-888-872-0690

<https://www.AngicGlobal.com> [Sales@AngicGlobal.com](mailto:Sales@AngicGlobal.com)



# 1/4 Turn Fasteners

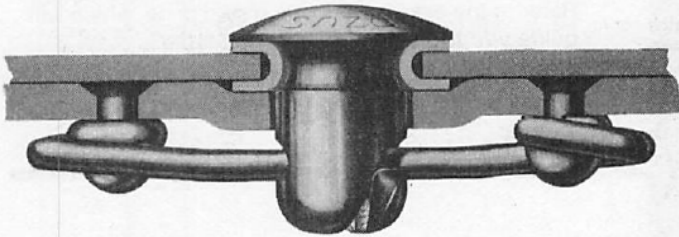

DZUS Standard Line offers the largest 1/4-turn fastener selection in the industry.

Every fastener in the line is based on the rugged spiral cam stud and spring-wire receptacle design. The advantages of this design are readily apparent when a Standard Line Fastener is operated in comparison with other 1/4-turn types, especially after prolonged use. The fastener provides a firm locking tension with a crisp and positive lock. The end of the stud cam presents a solid over-rotation stop. Wear is minimal and performance is maintained over thousands of use cycles. Stud shanks are smooth, with no pins or lugs to hang up in support holes.

Designers evaluating 1/4-turn fastener performance over the full service life of their product will find an outstanding choice in DZUS Standard Line.

**NOTE** —The selection and installation planning of fasteners can influence the security of the fastened parts. Dzus product information and support service is intended for use only by persons with mechanical engineering qualifications sufficient to manage the responsibilities of:

1. Analyzing fastener performance in relation to the service to be met, and
2. Planning appropriate fastening locations and installations.

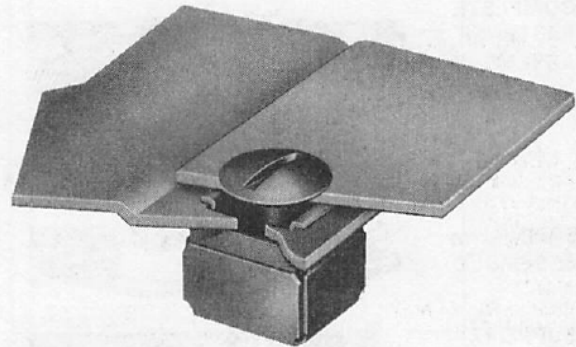
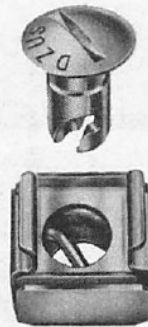

Standard Line fastener components consist of a spiral-cam stud, a stud retainer, and a receptacle consisting of, or containing a wire form spring.

As the stud is rotated, the DZUS 1/4-turn spiral cam engages the spring-wire receptacle and pulls it up and over the cam peak. The spring snaps into the detent at the end of the cam, holding the fastener in a firm locked tension. The cam peak resists opening rotation of a locked stud under vibration.

# SELECTION PROCEDURE

## TYPICAL ASSEMBLY

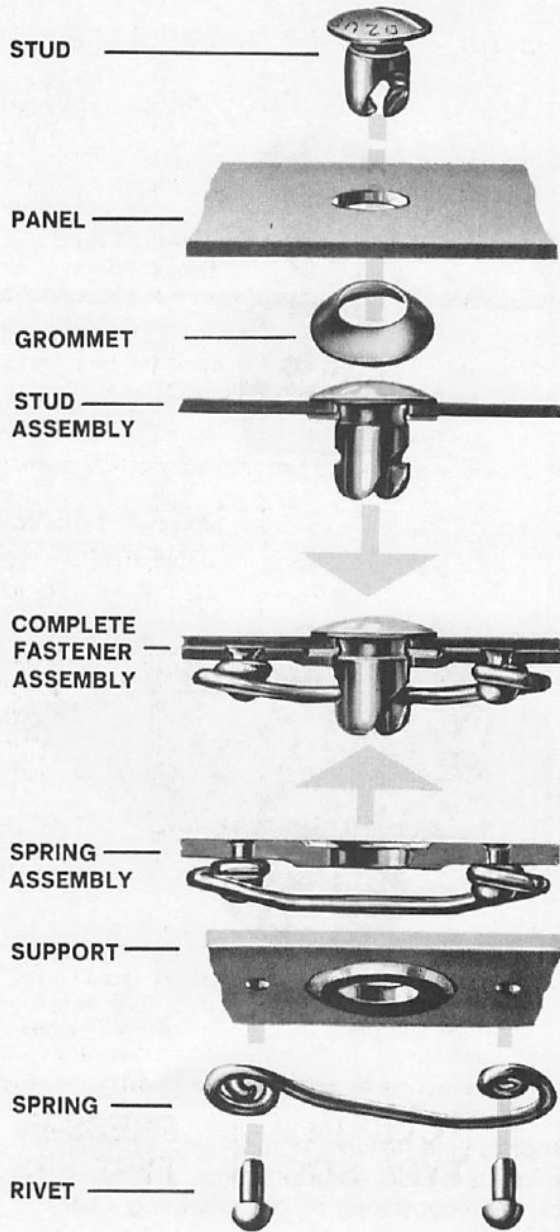

### STANDARD LINE PERFORMANCE

Fastener Size	3	4	5	6	7
Stud End Dia.	3/16	1/4	5/16	3/8	7/16
Stud Head Dia.	5/16	7/16	9/16	5/8 *	3/4
Locked Service Tension (lbs.)	20	30	45	55	65
Max. Tension w/o Distortion (lbs.)	45	60	85	110	125
Rated Shear (lbs.)	100	150	200	300	350
Wear Life (uses)	5M	5M	25M	40M	40M

Max. Sheet Separation at 150% of Locked Service Tension: 3/64

\* Oval head only

STUDS

STUD RETAINERS

RECEPTACLES

1. Select a fastener size, using the performance table at lower left.
2. Select an appropriate stud head style.
3. Select a stud retainer (see steps 3A-D).
4. Select a receptacle type (see step 4A).
5. Now determine the thickness of material in which the stud is retained (shown in tables as panel 'P') and to which the receptacle is attached (shown in tables as support 'Q'). Then determine the total gap between the level of stud head contact with material and the level of receptacle contact, in the closed position. Include any air gaps and any part of the stud retainer thickness not buried in material already measured. Refer to the examples on each stud page, which will guide you to the length selection table.
6. Self-ejecting stud assemblies prevent stud play in open position and provide a visual cue of an open fastener.

3. Some criteria for retainer selection are:
  - A Desirability of radial and axial stud play in unlocked position.
  - B Degree of protection needed for panel hole and outer surface.
  - C Whether retainer may be allowed to cause a gap between stud panel and receptacle support, or must be absorbed into one of those materials or into the receptacle itself.
  - D Installed cost.

- 4A. All of the receptacles shown to the right provide the same optimum performance standards as listed in the table at lower left, so receptacle selection is primarily a matter of choosing the installation mode which provides the lowest installed cost, and perhaps finding a type that will fit in limited space.

If stainless steel is required, the wire-form springs, weld plates, and press-in types are available. If a fully-enclosed type is needed, selection is limited to the press-in, plus the enclosed types available in Supersonic Line and Panel Line.

## COMPONENTS







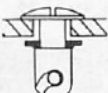

<b>AJ HEAD</b>	<b>FJ HEAD</b>	<b>AJW HEAD</b>	<b>BJR HEAD</b>
			
AVAILABLE IN SIZES 3 THRU 7 SEE ALSO NEW HEAD STYLES, P. 25			

<b>SELF-EJECTING SE</b>	<b>EHF</b>
	
Sizes 3, 4, 5	Size 5
See pg. 24.	

<b>ASJ HEAD</b>	<b>AHJ HEAD</b>	<b>APJ HEAD</b>
		
NEW HEAD STYLES See pg. 25.		

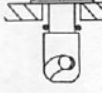
Special stud dimensions, materials and finishes are possible. Inquiries on special products are welcomed. Detailed stud

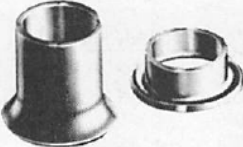
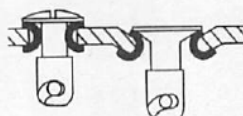
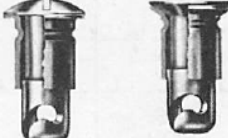
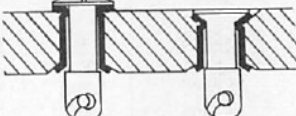
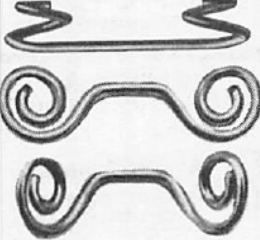
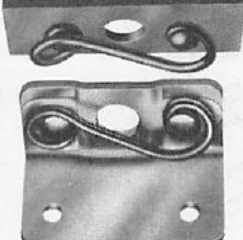
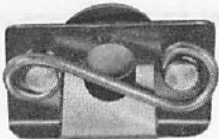
descriptions will be found on succeeding pages, beginning with Size 3 on Page 8. See Page 25 for Typical Special Studs.

<p><b>HALF GROMMET GH</b></p>   <p>Solid. Retains when flattened.</p>	<p><b>HALF GROMMET GP</b></p>   <p>Plastic push-on retainer. Also used under head to protect panel finish</p>	<p><b>SNAP RING SR</b></p>   <p>Split rings install fast, take little space</p>	<p><b>RETAINING SPRING SX</b></p>   <p>Holds stud in locking position for alignment with receptacle</p>	<p><b>FULL GROMMETS GA GF</b></p>   <p>Prevent panel hole wear, protect panel finish, reduce stud play.</p>	<p><b>THICK PANEL GROMMETS GSA GSF</b></p>   <p>Retain studs in thick panels. Protect panel finish under head. Made to order and supplied attached to studs.</p>
<p><b>SPRING TYPES S, SB, SC</b></p>  <p>Lightweight, rugged wire form springs rivet to supports parallel to, or perpendicular to stud panel.</p>	<p><b>SPRING PLATES, FLAT &amp; 90° BEND</b></p>  <p>S-springs are riveted to bare support plates, for welding to support. Flat plates sizes 3 through 7, 90° plates sizes 3, 4, 5.</p>	<p><b>SLIP-ON TYPE SL</b></p>  <p>Type SL receptacle snaps into round hold near support edge. Exceptionally rugged. Sizes 4 and 5.</p>	<p><b>CLIP-IN TYPE SQC</b></p>  <p>Compact Type SQC receptacle snaps into square hole. Provides a firm lock. Suitable for rack-mounted systems. Size 4.</p>	<p><b>PRESS-IN TYPE SPS</b></p>  <p>Dust-sealed Type SPS receptacles are self-clinching when pressed into a round hole in any ductile metal. Size 3 and 4.</p>	

**STUDS**

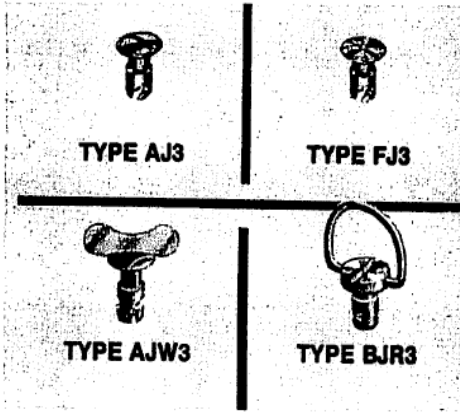

**STANDARD MATERIAL AND FINISHES**  
Hardened carbon steel studs, hard music wire D-rings, carbon steel wings. Bright zinc plate with clear chromate finish.

**OPTIONAL STAINLESS STEEL:** All parts 300-series stainless. Add **SS** to basic part no. Special order.

**OPTIONAL BLACK** Zinc plate as above with bright black chromate finish. Add suffix **ZBB** to basic part no.

**DZUS STUD PART NUMBERS**

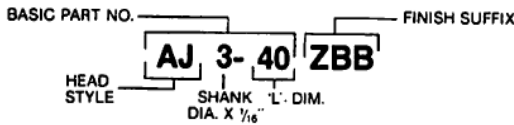

DZUS STUD PART NUMBERS						
OVAL HEAD AJ	Weight (lbs.)	B Dim.*	FLUSH HEAD FJ	Weight (lbs.)	B Dim.*	L Dim.
AJ3-20	.0015	.075	—	—	—	.200
AJ3-25	.0018	.075	FJ3-25	.0016	.150	.250
AJ3-30	.0021	.100	FJ3-30	.0019	.150	.300
AJ3-35	.0024	.150	FJ3-35	.0022	.175	.350
AJ3-40	.0026	.200	FJ3-40	.0025	.200	.400
AJ3-45	.0029	.225	FJ3-45	.0028	.225	.450
AJ3-50	.0033	.250	FJ3-50	.0031	.250	.500
AJ3-55	.0036	.275	FJ3-55	.0034	.275	.550
AJ3-60	.0039	.300	FJ3-60	.0037	.300	.600
AJ3-65	.0042	.350	FJ3-65	.0040	.350	.650
AJ3-70	.0045	.350	FJ3-70	.0043	.350	.700
AJ3-75	.0048	.400	FJ3-75	.0046	.400	.750
NOTE: LONGER STUD LENGTHS SPECIALLY AVAILABLE IN INCREMENTS OF .050.						
AJ3-250	.0147	.500	FJ3-250	.0150	.500	2.500

\* CAN BE SUPPLIED WITHOUT UNDERCUT, ON SPECIAL ORDER. SEE PAGE 25.  
TYPE AJW AND BJR STUDS AVAILABLE IN SAME LENGTHS AND 'B' DIMENSIONS AS TYPE AJ.

**OVAL HEAD STUDS**  
Type AJ

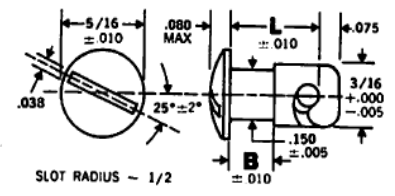

**FLUSH HEAD STUDS**  
Type FJ

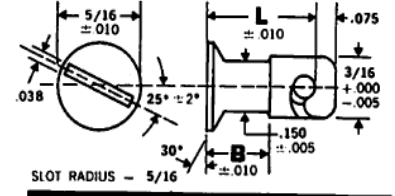

**WING HEAD STUDS**  
Type AJW

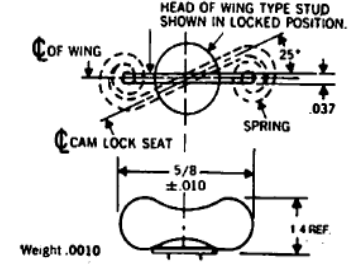

**RING HEAD STUDS**  
Type BJR

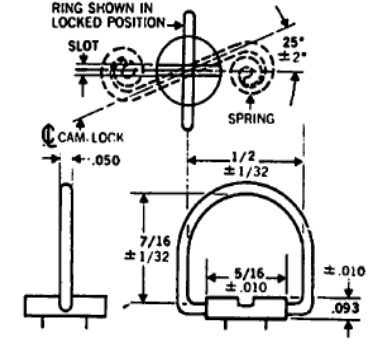

**OPTIONAL EJECTING STUDS**

**TYPE SE**  
See P. 24

**FASTENER SELECTION, USING S-SPRINGS OR WELD PLATES**

- FIND YOUR TOTAL THICKNESS.\***  
Total thickness refers to your material pileup at the fastening point, with stud attached and material in position for fastener engagement, as shown in typical assemblies.
- REFER TO SELECTION TABLE ON P. 26 OR . . .**  
**CALCULATE STUD 'L' DIM. AND RECEPTABLE 'H' DIM.**  
Stud 'L' Dim. must equal your total thickness, plus receptacle 'H' Dim., minus receptacle spring deflection within recommended range.

**NOTE:** Ensure that stud undercut (B Dim.) is long enough to accept panel and stud retainer.

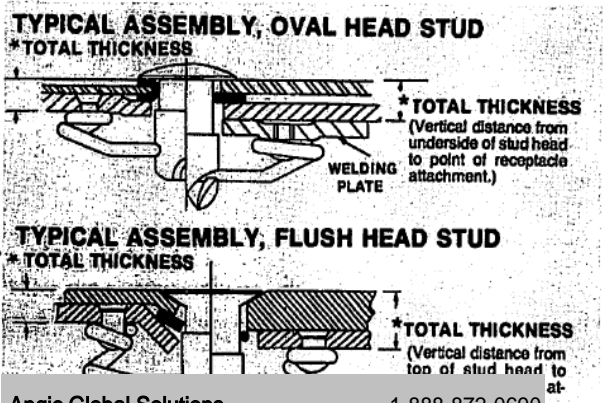

# SIZE 3 STUD RETAINERS & RECEPTACLES



## STUD RETAINERS



**TYPE GA  
FULL GROMMET**  
Installed View, P. 29



**TYPE GP  
HALF GROMMET**  
Installed View, P. 28



**TYPE GH  
HALF GROMMET**  
Installed View, P. 28

### TYPE GA FULL GROMMET

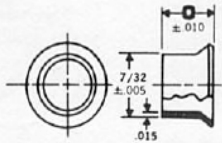

For use with all Standard Line studs except flush heads.

Part No.: GA3-(Dim. 0)  
GA3-175 = 0: .175  
Material: Aluminum.  
Available in lengths to fit most common panel gages.  
Selection tables on Page 23.  
Weight (lbs.): .0002

### TYPE GH HALF GROMMET

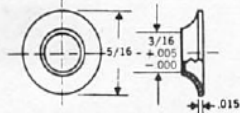

For use with all Standard studs.

Part No.: GH3  
Material: Aluminum  
Weight (lbs.): 00013

### TYPE GP HALF GROMMET

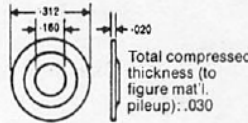

For use with all Standard Line studs.

Part No.: GP3B  
Material: Black Thermoplastic  
Push-out strength:  
Standard panel hole: 25 lb.  
Oversize panel hole: 7 lb.  
Weight (lbs.): 00005

### SNAP RING

For use with all Standard studs

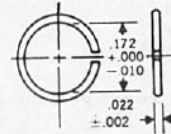

Installed View, P.29  
Part No. SR3SS  
Material: Stainless steel, 300 series, spring temper.  
Weight (lbs): .00007

### RETAINING SPRING

Installed View, P. 7, 28

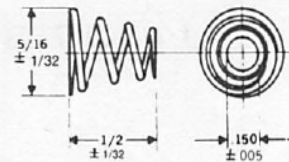

Part No.: SX520SS  
Material: Stainless steel, 300 series, spring temper.  
Weight (lbs): .00031

## RECEPTACLES

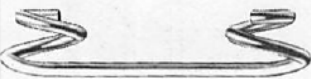

**TYPE S SPRING**



**FLAT SPRING PLATE**

### TYPE S SPRING

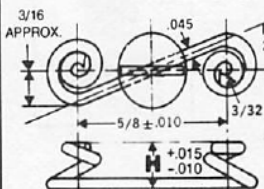

Part No.	'H' Dim.
S3-150	.150
S3-175	.175
S3-200	.200
S3-225	.225

Recommended Deflection  
.020 to .045

Installed View, PP. 30, 32.

Material: Music wire, bright zinc plate with yellow chromate dip. Stainless Steel, 300 series on special order. Add suffix **SS** to basic part no.  
Weight (lbs.): .0009

### FLAT SPRING PLATE

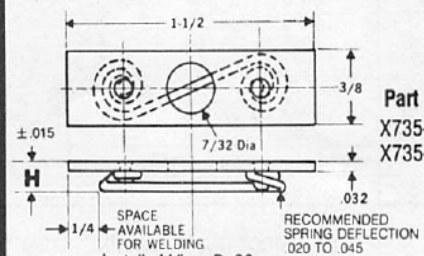

Part No.	'H' Dim.
X735-205	.205
X735-230	.230

Installed View, P. 30

Material: Plate is steel, unfinished. Spring as described. Plated steel rivets. Stainless steel on special order: All parts 300-series. Add suffix **SS** to basic Part No.  
Weight (lbs.): .0061

### SIDE-MOUNTED SPRINGS

#### TYPE SB



#### TYPE SC



Rivets to support perpendicular to stud panel.

### RIGHT-ANGLE SPRING PLATE TYPE RP

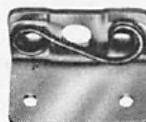

For riveting or welding to support perpendicular to stud panel.

### PRESS-IN RECEPTACLE TYPE SPS



Presses into sheet metal. Dust-sealed.



For

Get quote

Details or

Angic Global Solutions

1-888-872-0690

<https://www.AngicGlobal.com> [Sales@AngicGlobal.com](mailto:Sales@AngicGlobal.com)

# FAST DZUS FASTENING

## SIZE 4 FLUSH, OVAL, WING & RING HEAD STUDS

### STUDS

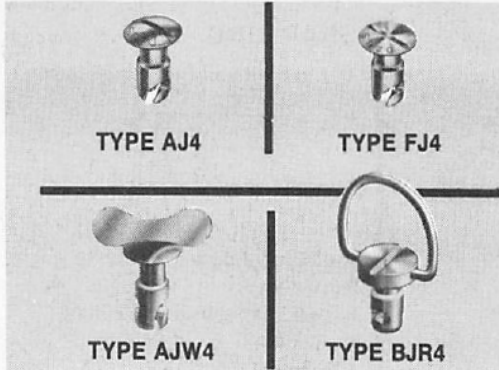

**STANDARD MATERIAL AND FINISHES**  
Hardened carbon steel studs, hard music wire D-rings, carbon steel wings. Bright zinc plate with clear chromate finish. Use basic part no.

**OPTIONAL STAINLESS STEEL:** All parts 300-series stainless. Add **SS** to basic part no. Special order.

**OPTIONAL BLACK** Zinc plate as above with bright black chromate finish. Add suffix **ZBB** to basic part no.

#### DZUS STUD PART NUMBERS



DZUS STUD PART NUMBERS						
OVAL HEAD AJ	Weight (lbs.)	B Dim.*	Flush Head FJ	Weight (lbs.)	B Dim.*	L Dim.
AJ4-25	.0033	.100	—	—	—	.250
AJ4-30	.0038	.100	—	—	—	.300
AJ4-35	.0043	.150	FJ4-35	.0040	.175	.350
AJ4-40	.0048	.200	FJ4-40	.0045	.200	.400
AJ4-45	.0053	.225	FJ4-45	.0050	.225	.450
AJ4-50	.0058	.250	FJ4-50	.0055	.250	.500
AJ4-55	.0063	.275	FJ4-55	.0060	.275	.550
AJ4-60	.0069	.300	FJ4-60	.0064	.300	.600
AJ4-65	.0074	.350	FJ4-65	.0069	.350	.650
AJ4-70	.0078	.350	FJ4-70	.0075	.350	.700
AJ4-75	.0083	.400	FJ4-75	.0080	.400	.750
AJ4-80	.0088	.400	FJ4-80	.0086	.400	.800
NOTE: LONGER STUD LENGTHS SPECIALLY AVAILABLE IN INCREMENTS OF .050.						
AJ4-250	.020	.600	FJ4-250	.0180	.600	2.500

\* CAN BE SUPPLIED WITHOUT UNDERCUT, ON SPECIAL ORDER. SEE PAGE 25.  
TYPE AJW AND BJR STUDS AVAILABLE IN SAME LENGTHS AND 'B' DIMENSIONS AS TYPE AJ.

#### OVAL HEAD STUDS Type AJ

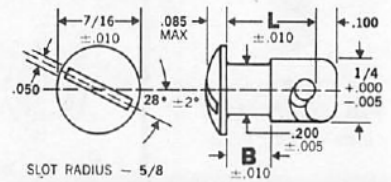

#### FLUSH HEAD STUDS Type FJ

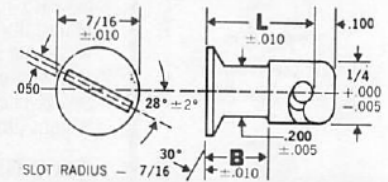

#### WING HEAD STUDS Type AJW

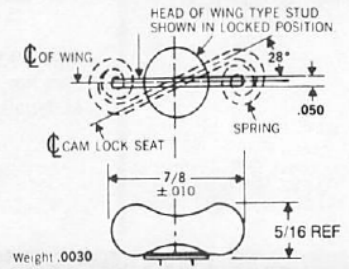

#### RING HEAD STUDS Type BJR

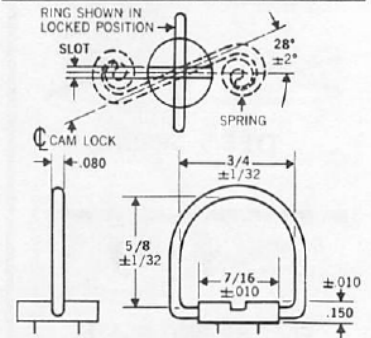

#### OPTIONAL EJECTING STUDS



TYPE SE  
See P. 24

#### FASTENER SELECTION, USING S-SPRINGS OR WELD PLATES

##### 1. FIND YOUR TOTAL THICKNESS.\*

Total thickness refers to your material pileup at the fastening point, with stud attached and material in position for fastener engagement, as shown in typical assemblies.

##### 2. REFER TO SELECTION TABLE ON P. 26 OR . . .

##### CALCULATE STUD 'L' DIM. AND RECEPTABLE 'H' DIM.

Stud 'L' Dim. must equal your total thickness, plus receptacle 'H' Dim., minus receptacle spring deflection within recommended range.

NOTE: Ensure that stud undercut (B Dim.) is long enough to accept panel

#### TYPICAL ASSEMBLY, OVAL HEAD STUD

\* TOTAL THICKNESS

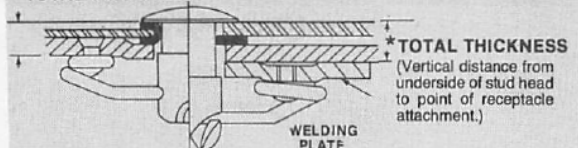

#### TYPICAL ASSEMBLY, FLUSH HEAD STUD

\* TOTAL THICKNESS

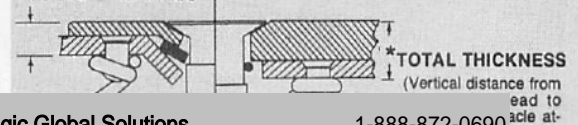

# SIZE 4 STUD RETAINERS & RECEPTACLES



## STUD RETAINERS



**TYPE GA FULL GROMMET**  
For use with all Standard Line studs  
except flush heads

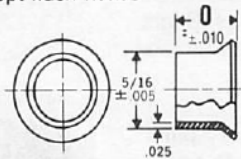

Typical Part No.: GA4-250 (0 = .250) \*  
Material: Aluminum.

\*Available in lengths to fit most common panel gages. Selection tables on Page 23.



**TYPE GF FULL GROMMET**  
For use with FJ studs

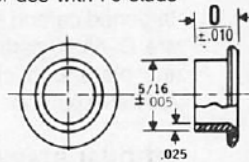

Typical Part No.: GF4-150 (0 = .150) \*  
Material: Aluminum.



**TYPE GH HALF GROMMET**  
For use with all Standard studs

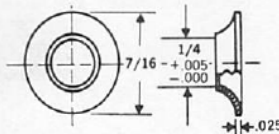

Part No.: GH4  
Materials: Aluminum.  
Weight (lbs.): .00034

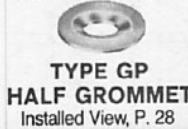

**TYPE GP HALF GROMMET**  
For use with all Standard studs

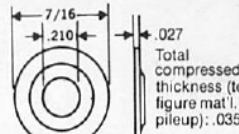

Part No.: GP4B  
Material: Black Thermoplastic  
Retainer Strength (fastener push-out):  
Standard panel hole—25 lbs. min.  
Oversize panel hole—9 lbs. min.  
Weight (lbs.): .00011

### SNAP RING

For use with all Standard studs  
Installed  
View,  
P. 28

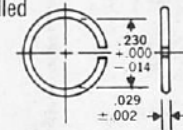

Part No.: SR4SS  
Material: Stainless steel, 300 series,  
spring temper.  
Weight (lbs): .00015

### RETAINING SPRING

Installed View, Pp. 7, 28

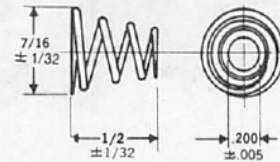

Part No.: SX523SS  
Material: Stainless steel, 300 series,  
spring temper.  
Weight (lbs): .00069

## RECEPTACLES



### TYPE S SPRING

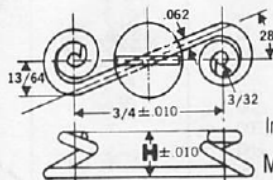

Part No.	'H' Dim.
S4-200	.200
S4-225	.225
S4-250	.250
S4-275	.275

Installed View, Pp. 30, 32

Material: Music wire, bright zinc  
plate with yellow chromate dip.  
Stainless Steel, 300 series on  
special order. Add suffix **SS** to  
basic part no.  
Weight (lbs.): .0025

Recommended Deflection  
.022 to .054



### FLAT SPRING PLATE

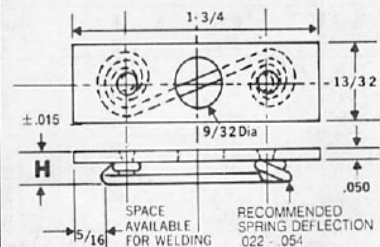

Part No.	'H' Dim.
X485-275	.275
X485-300	.300

Installed View, P. 30

Material: Plate is steel, unfinished.  
Spring as described. Plated steel  
rivets. Stainless steel on special  
order: All parts 300-series. Add  
suffix **SS** to basic part no.  
Weight (lbs.): .0124

### SIDE-MOUNTED SPRINGS TYPE SB



Rivet to supports perpen-  
dicular to stud panel.

DETAILS ON P. 22

### RIGHT-ANGLE SPRING PLATE TYPE RP

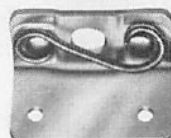

For riveting or welding to  
support perpendicular to  
stud panel.

DETAILS ON P. 22

### SLIP-ON RECEPTACLE TYPE SL

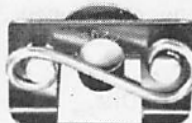

Slips over round hole  
near support edge.  
Secure retention.

DETAILS ON P. 20

### CLIP-IN RECEPTACLE TYPE SQC



Snaps into square  
holes. Secure, compact.

DETAILS ON P. 18

### PRESS-IN RECEPTACLE TYPE SPS



Presses into sheet metal.  
Dust-sealed.

DETAILS ON P. 19

For Standard



Get quote

Angic Global Solutions

1-888-872-0690

<https://www.AngicGlobal.com> [Sales@AngicGlobal.com](mailto:Sales@AngicGlobal.com)

## STUDS

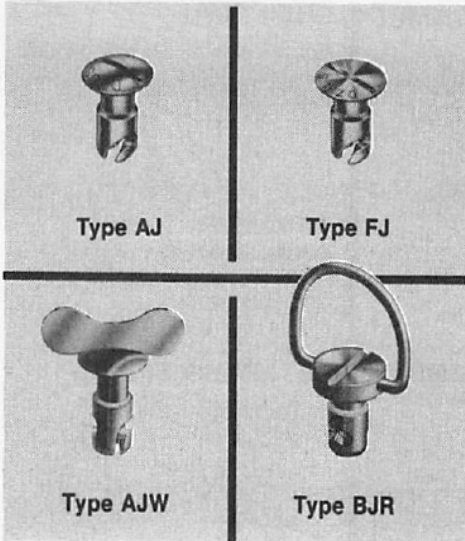

**STANDARD MATERIAL AND FINISHES**  
Hardened carbon steel studs, hard music wire D-rings, carbon steel wings. Bright zinc plate with clear chromate finish. Use basic part no.

**OPTIONAL STAINLESS STEEL:** All parts 300-series stainless. Add **SS** to basic part no. Special order.

**OPTIONAL BLACK** Zinc plate as above with bright black chromate finish. Add suffix **ZBB** to basic part no.

### OVAL HEAD STUDS Type AJ

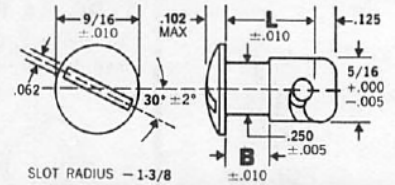

### FLUSH HEAD STUDS Type FJ

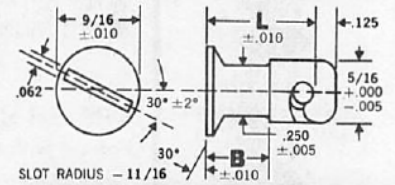

### WING HEAD STUDS Type AJW

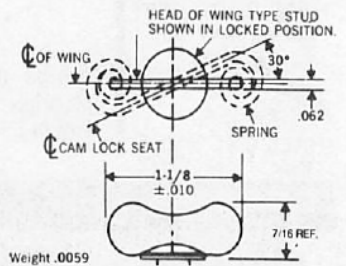

### RING HEAD STUDS Type BJR

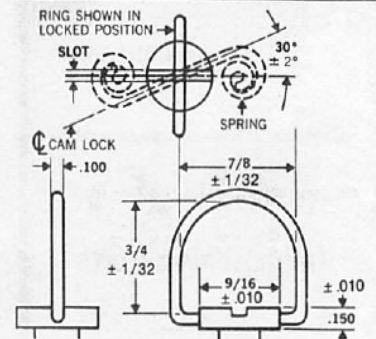

### DZUS STUD PART NUMBERS

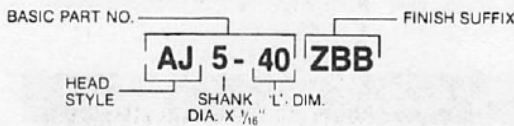

DZUS STUD PART NUMBERS						
OVAL HEAD AJ	Weight (lbs.)	B Dim.*	Flush Head FJ	Weight (lbs.)	B Dim.	L Dim*
AJ5-30	.0077	.125	—	—	—	.300
AJ5-40	.0085	.190	FJ5-40	.0083	.225	.400
AJ5-50	.0098	.250	FJ5-50	.0093	.250	.500
AJ5-60	.0111	.300	FJ5-60	.0103	.300	.600
AJ5-70	.0124	.400	FJ5-70	.0115	.400	.700
AJ5-80	.0137	.500	FJ5-80	.0123	.500	.800
AJ5-90	.0150	.600	FJ5-90	.0137	.600	.900

NOTE: LONGER STUD LENGTHS SPECIALLY AVAILABLE IN INCREMENTS OF .100.

AJ5-250	.0420	.700	FJ5-250	.0300	.700	2.500
---------	-------	------	---------	-------	------	-------

\* CAN BE SUPPLIED WITHOUT UNDERCUT, ON SPECIAL ORDER. SEE PAGE 25.  
TYPE AJW AND BJR STUDS AVAILABLE IN SAME LENGTHS AND 'B' DIMENSIONS AS TYPE AJ.

### OPTIONAL EJECTING STUDS



TYPE SE  
See P. 24

### FASTENER SELECTION, USING S-SPRINGS OR WELD PLATES

#### 1. FIND YOUR TOTAL THICKNESS.\*

Total thickness refers to your material pileup at the fastening point, with stud attached and material in position for fastener engagement, as shown in typical assemblies.

#### 2. REFER TO SELECTION TABLE ON P. 27 OR . . .

#### CALCULATE STUD 'L' DIM. AND RECEPTABLE 'H' DIM.

Stud 'L' Dim. must equal your total thickness, plus receptacle 'H' Dim., minus receptacle spring deflection within recommended range.

**NOTE:** Ensure that stud undercut (B Dim.) is long enough to accept panel and stud retainer.

### TYPICAL ASSEMBLY, OVAL HEAD STUD

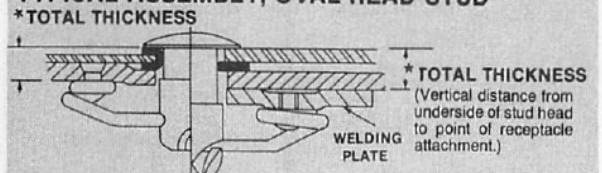

### TYPICAL ASSEMBLY, FLUSH HEAD STUD

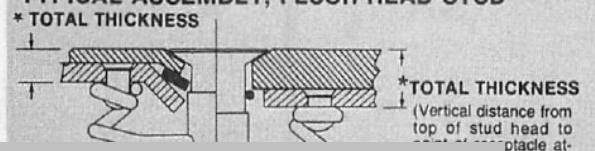

# SIZE 5 STUD RETAINERS & RECEPTACLES



## STUD RETAINERS



**TYPE GA  
FULL GROMMET**  
Installed View, P. 29



**TYPE GF  
FULL GROMMET**  
Installed View, P. 31



**TYPE GH  
HALF GROMMET**  
Installed View, P. 28



**TYPE GP  
HALF GROMMET**  
Installed View, P. 28

### TYPE GA FULL GROMMET

For use with all Standard Line studs, except flush heads.

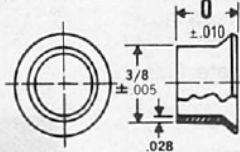

Typical Part No.: GA5-312 ("0" = .312)\*  
Material: aluminum.

### TYPE GF FULL GROMMET

For use with FJ studs

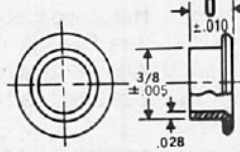

Typical Part No.: GF5-175 (0 = .175)\*  
Material: aluminum.

\*Available in lengths to fit most common panel gages. Selection tables on Page 23.

### TYPE GH HALF GROMMET

For use with all Standard studs

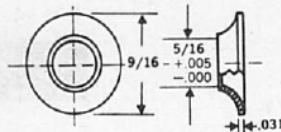

Part No.: GH5  
Materials: Aluminum.  
Weight (lbs.): .00069

### TYPE GP HALF GROMMET

For use with all Standard studs

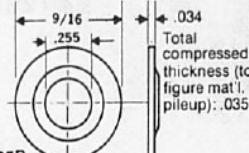

Part No.: GP5B  
Material: Black Thermoplastic  
Retainer Strength (fastener push-out):  
Standard panel hole—50 lbs. min.  
Oversize panel hole—16 lbs. min.  
Weight (lbs.): .0002

### SNAP RING

For use with all Standard studs

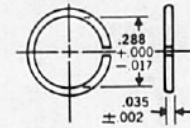

Part No.: SR5SS  
Installed View, P. 28  
Material: Stainless steel, 300 series,  
spring temper.  
Weight (lbs): .00027

### RETAINING SPRING

Installed View, Pp. 7, 28.

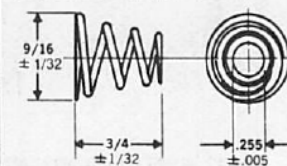

Part No.: SX510SS  
Material: Stainless steel, 300 series,  
spring temper.  
Weight (lbs): .00144

## RECEPTACLES



**TYPE S5A SPRING**



**FLAT SPRING PLATE**

### TYPE S5A SPRINGS

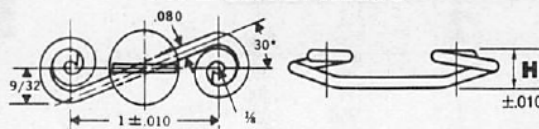

Recommended Deflection  
.024 to .057

Material: Music wire, bright zinc plate with yellow chromate dip. Stainless steel, 17-7 PH on special order. Add suffix **SS** to basic part no. Weight (lbs.): .0059

Installed View, Pp. 30, 32

Part No.	'H' Dim.
S5A-200	.200
S5A-225	.225
S5A-250	.250
S5A-275	.275

### FLAT SPRING PLATE

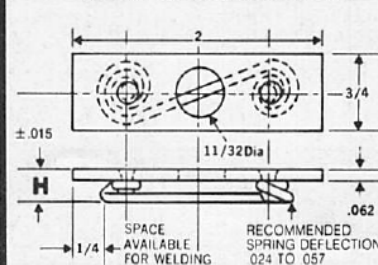

Part No.	'H' Dim.
X414-285	.285
X414-310	.310
X414-335	.335
X414-360	.360

Installed View, P. 30

Material: Plate is steel, unfinished. Spring as described. Plated steel rivets. Stainless steel on special order: Rivets and plate 300-series, spring 17-7PH. Add suffix **SS** to basic part no. Weight (lbs.): .0326

### SIDE-MOUNTED SPRINGS

#### TYPE SB



#### TYPE SC



Rivets to support perpendicular to stud panel.

### RIGHT-ANGLE SPRING PLATE

#### TYPE RP

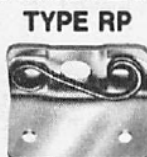

For riveting or welding to support perpendicular to stud panel.

### SLIP-ON RECEPTACLE

#### TYPE SL

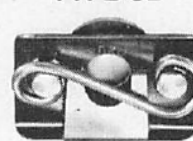

Slips over round hole near support edge. Secure retention.

## STUDS

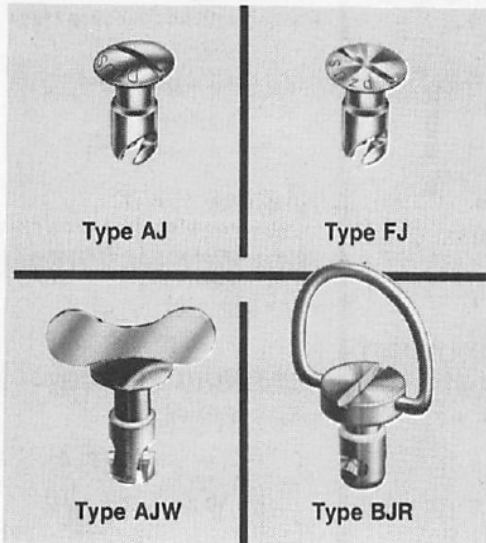

**STANDARD MATERIAL AND FINISHES**  
Hardened carbon steel studs, hard music wire D-rings, carbon steel wings. Bright zinc plate with clear chromate finish. Use basic part no.

**OPTIONAL STAINLESS STEEL:** All parts 300-series stainless. Add **SS** to basic part no. Special order.

**OPTIONAL BLACK** Zinc plate as above with bright black chromate finish. Add suffix **ZBB** to basic part no.

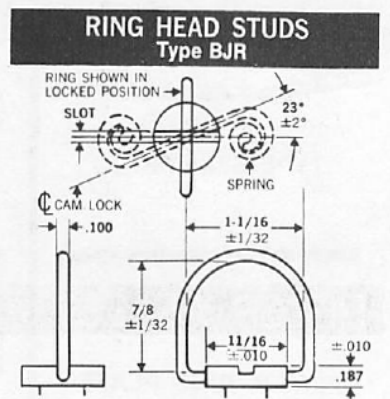
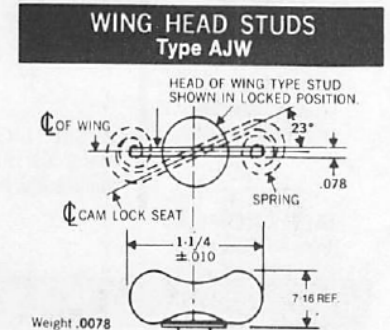
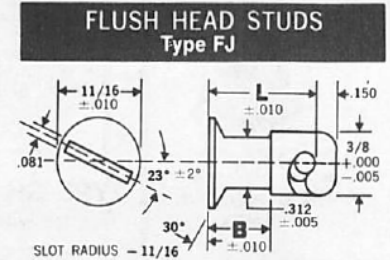
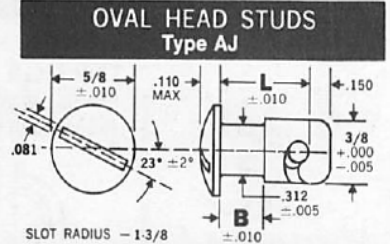

### DZUS STUD PART NUMBERS

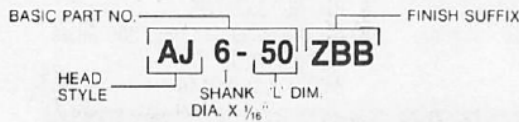

DZUS STUD PART NUMBERS						
OVAL HEAD AJ	Weight (lbs.)	B Dim.*	Flush Head FJ	Weight (lbs.)	B Dim.	L Dim.
AJ6-35	.0111	.150	—	—	—	.350
AJ6-40	.0120	.190	—	—	—	.400
AJ6-50	.0138	.250	FJ6-50	.0126	.250	.500
AJ6-60	.0156	.300	FJ6-60	.0144	.300	.600
AJ6-70	.0176	.350	FJ6-70	.0164	.350	.700
AJ6-80	.0196	.450	FJ6-80	.0184	.450	.800
AJ6-90	.0216	.550	FJ6-90	.0202	.550	.900
AJ6-100	.0236	.650	FJ6-100	.0224	.650	1.000
NOTE: LONGER STUD LENGTHS SPECIALLY AVAILABLE IN INCREMENTS OF .100.						
AJ6-200	.0432	.650	FJ6-200	.0282	.650	2.000

\* CAN BE SUPPLIED WITHOUT UNDERCUT, ON SPECIAL ORDER. SEE PAGE 25.  
TYPE AJW AND BJR STUDS AVAILABLE IN SAME LENGTHS AND 'B' DIMENSIONS AS TYPE AJ.

### FASTENER SELECTION, USING S-SPRINGS OR WELD PLATES

#### 1. FIND YOUR TOTAL THICKNESS.\*

Total thickness refers to your material pileup at the fastening point, with stud attached and material in position for fastener engagement, as shown in typical assemblies.

#### 2. REFER TO SELECTION TABLE ON P. 27. OR . . .

#### CALCULATE STUD 'L' DIM. AND RECEPTABLE 'H' DIM.

Stud 'L' Dim. must equal your total thickness, plus receptable 'H' Dim., minus receptable spring deflection within recommended range.

**NOTE:** Ensure that stud undercut (B Dim.) is long enough to accept panel and stud retainer.

### TYPICAL ASSEMBLY, OVAL HEAD STUD

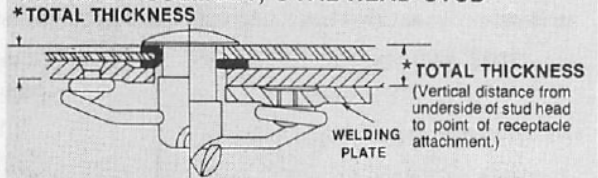

### TYPICAL ASSEMBLY, FLUSH HEAD STUD

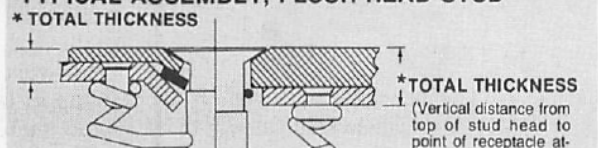

For I



Get quote

Angic Global Solutions

1-888-872-0690

<https://www.AngicGlobal.com> Sales@AngicGlobal.com

# SIZE 6 STUD RETAINERS & RECEPTACLES



## STUD RETAINERS



**TYPE GA  
FULL GROMMET**  
Installed View, P. 29



**TYPE GF  
FULL GROMMET**  
Installed View, P. 31



**TYPE GH  
HALF GROMMET**  
Installed View, P. 28



**TYPE GP  
HALF GROMMET**  
Installed View, P. 28

### TYPE GA FULL GROMMET

For use with all Standard Line studs, except flush heads.

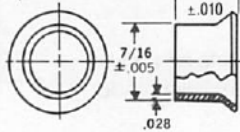

Typical Part No.: GA6-350 (O. = .350)\*  
Material: aluminum

### TYPE GF FULL GROMMET

For use with FJ studs

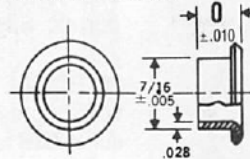

Typical Part No.: GF6-250 (O. = .250)\*  
Material: aluminum

\*Available in lengths to fit most common panel gages.  
Selection tables on Page 23.

### TYPE GH HALF GROMMET

For use with all Standard studs

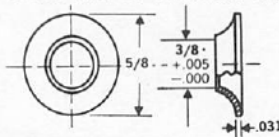

Part No.: GH6  
Materials: Aluminum.  
Weight (lbs.): .00081

### TYPE GP HALF GROMMET

For use with all Standard studs

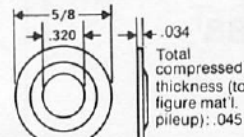

Part No.: GP6B  
Material: Black Thermoplastic  
Retainer Strength (fastener push-out):  
Standard panel hole—50 lbs. min.  
Oversize panel hole—16 lbs. min.  
Weight (lbs.): .00021

### SNAP RING

For use with all Standard studs  
Installed View, P. 28

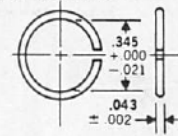

Part No.: SR6SS  
Material: Stainless steel, 300 series,  
spring temper.  
Weight (lbs): .00050

### RETAINING SPRING

Installed View, Pp. 7, 28

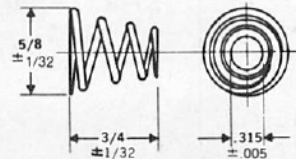

Part No.: SX518SS  
Material: Stainless steel, 300 series,  
spring temper.  
Weight (lbs): .00194

## RECEPTACLES



**TYPE S6A SPRING**



**FLAT SPRING PLATE**

### TYPE S6A SPRINGS

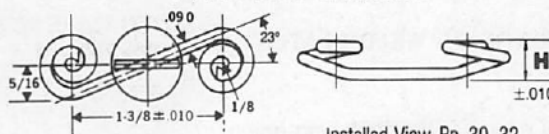

Installed View, Pp. 30, 32  
Recommended Deflection  
.031 to .074

Material: Music wire, bright zinc plate with yellow chromate dip. Stainless Steel, 17-7 PH on special order. Add suffix **SS** to basic part no. Weight (lbs.): .0082

Part No.	'H' Dim.
S6A-225	.225
S6A-250	.250
S6A-275	.275
S6A-300	.300

### FLAT SPRING PLATE

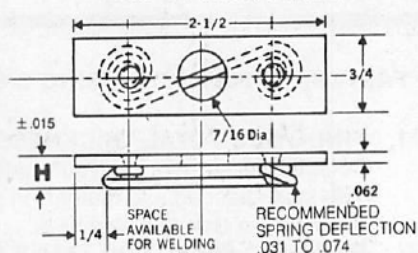

Part No.	'H' Dim.
X441-310	.310
X441-335	.335
X441-360	.360
X441-385	.385

Installed View, P. 30  
Material: Plate is steel, unfinished. Spring as described. Plated steel rivets. Stainless steel on special order. Rivets and plate 300-series, spring 17-7 PH. Add suffix



**STUDS**

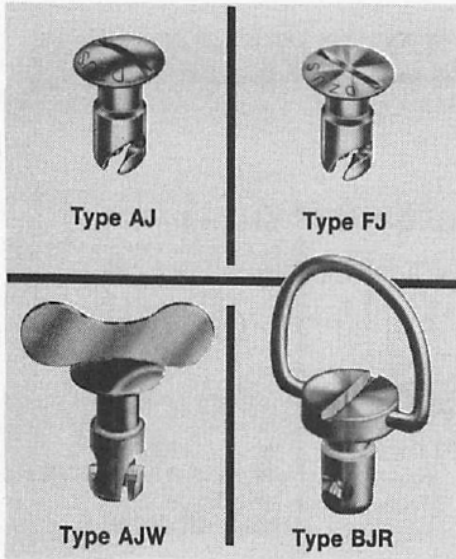

**STANDARD MATERIAL AND FINISHES**  
Hardened carbon steel studs, hard music wire D-rings, carbon steel wings. Bright zinc plate with clear chromate finish. Use basic part no.

**OPTIONAL STAINLESS STEEL:** All parts 300-series stainless. Add **SS** to basic part no. Special order.

**OPTIONAL BLACK** Zinc plate as above with bright black chromate finish. Add suffix **ZBB** to basic part no.

**OVAL HEAD STUDS**  
Type AJ

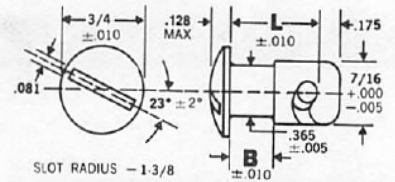

**FLUSH HEAD STUDS**  
Type FJ

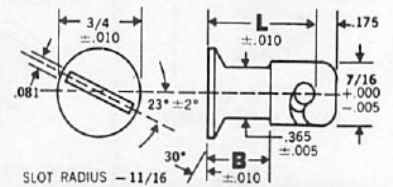

**WING HEAD STUDS**  
Type AJW

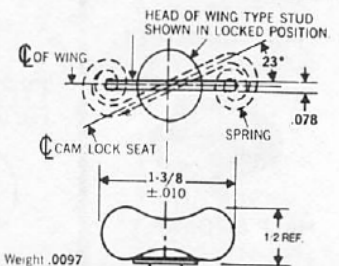

**RING HEAD STUDS**  
Type BJR

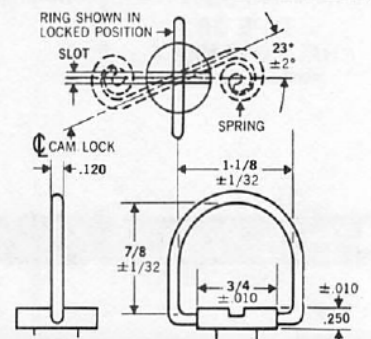

**DZUS STUD PART NUMBERS**

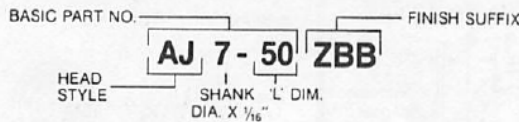

DZUS STUD PART NUMBERS						
OVAL HEAD AJ	Weight (lbs.)	B Dim.*	Flush Head FJ	Weight (lbs.)	B Dim.*	L Dim.
AJ7-35	.0175	.175	—	—	—	.350
AJ7-40	.0200	.190	—	—	—	.400
AJ7-50	.0225	.250	FJ7-50	.0210	.250	.500
AJ7-60	.0250	.300	FJ7-60	.0240	.300	.600
AJ7-70	.0281	.350	FJ7-70	.0270	.350	.700
AJ7-80	.0310	.450	FJ7-80	.0300	.450	.800
AJ7-90	.0340	.550	FJ7-90	.0330	.550	.900
AJ7-100	.0370	.650	FJ7-100	.0360	.650	1.000
NOTE: LONGER STUD LENGTHS SPECIALLY AVAILABLE IN INCREMENTS OF .100.						
AJ7-200	.0790	.650	FJ7-200	.0770	.650	2.000

\* CAN BE SUPPLIED WITHOUT UNDERCUT, ON SPECIAL ORDER. SEE PAGE 25.  
TYPE AJW AND BJR STUDS AVAILABLE IN SAME LENGTHS AND 'B' DIMENSIONS AS TYPE AJ.

**FASTENER SELECTION, USING S-SPRINGS OR WELD PLATES**

- FIND YOUR TOTAL THICKNESS.\***  
Total thickness refers to your material pileup at the fastening point, with stud attached and material in position for fastener engagement, as shown in typical assemblies.
- REFER TO SELECTION TABLE ON P. 27. OR . . .**  
**CALCULATE STUD 'L' DIM. AND RECEPTABLE 'H' DIM.**  
Stud 'L' Dim. must equal your total thickness, plus receptacle 'H' Dim., minus receptacle spring deflection within recommended range.

**NOTE:** Ensure that stud undercut (B Dim.) is long enough to accept panel and stud retainer.

**TYPICAL ASSEMBLY, OVAL HEAD STUD**

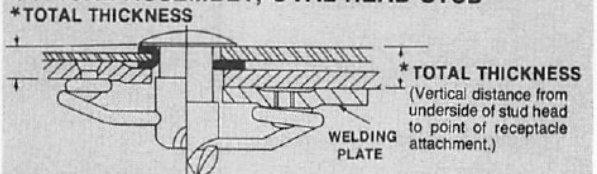

**TYPICAL ASSEMBLY, FLUSH HEAD STUD**

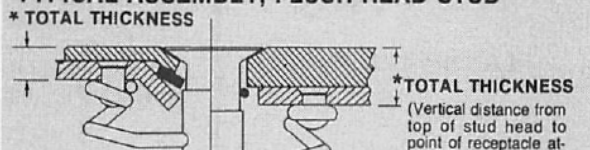

For



Get quote

Angic Global Solutions

1-888-872-0690

<https://www.AngicGlobal.com> [Sales@AngicGlobal.com](mailto:Sales@AngicGlobal.com)

# SIZE 7 STUD RETAINERS & RECEPTACLES



## STUD RETAINERS



**TYPE GA  
FULL GROMMET**  
Installed View, P. 29



**TYPE GF  
HALF GROMMET**  
Installed View, P. 31



**TYPE GH  
HALF GROMMET**  
Installed View, P. 28

**TYPE GA FULL GROMMET**  
For use with all Standard Line studs, except flush heads.

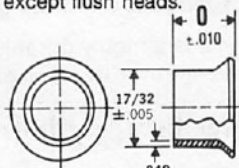

Typical Part No.: GA7-375 ("0" = .375)\*  
Material: Aluminum

**TYPE GF FULL GROMMET**  
For use with FJ studs

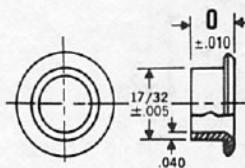

Typical Part No.: GF7-250 (0 = .250)\*  
Material: aluminum.

\*Available in lengths to fit most common panel gages. Selection tables on Page 23.

**TYPE GH HALF GROMMET**  
For use with all Standard studs

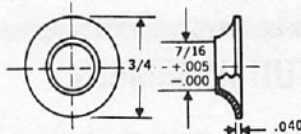

Part No.: GH7  
Material: Aluminum.  
Weight (lbs.): .0015

### SNAP RING

For use with all Standard studs  
Installed View,  
P. 28

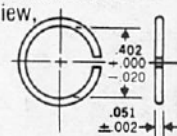

Part No.: SR7SS  
Material: Stainless steel, 300 series,  
spring temper.  
Weight (lbs): .00081

### RETAINING SPRING

Installed View, Pp. 7, 28.

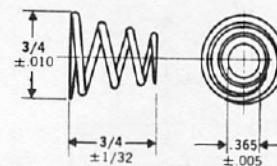

Part No.: SX519SS  
Material: Stainless steel, 300 series,  
spring temper.  
Weight (lbs): .00363

## RECEPTACLES

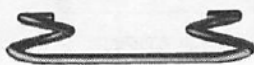

**TYPE S SPRING**



**FLAT SPRING PLATE**

### TYPE S SPRING

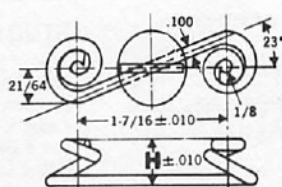

Part No.	'H' Dim.
S7-225	.225
S7-250	.250
S7-275	.275
S7-300	.300

Installed View, P. 30, 32.  
Recommended Deflection .031 to .074.

Material: Music wire, bright zinc plate with yellow chromate dip. Stainless Steel, 300 series on special order. Add suffix **SS** to basic part no.  
Weight (lbs.): .0100

### FLAT SPRING PLATE

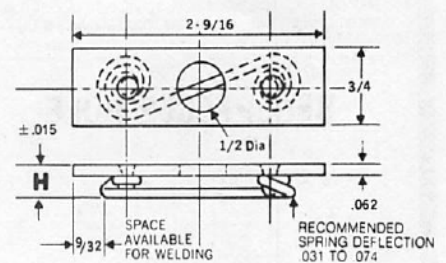

Installed View, P. 30  
Material: Plate is steel, unfinished.  
Spring as described. Plated steel rivets. Stainless steel on special order: All parts 300-series. Add suffix **SS** to basic Part No.  
Weight (lbs.): .0428

Part No.	'H' Dim.
X442-310	.310
X442-335	.335
X442-360	.360
X442-385	.385

# FAST DZUS FASTENING

## SIZE 4 SQUARE HOLE CLIP-IN RECEPTACLE, SQC4

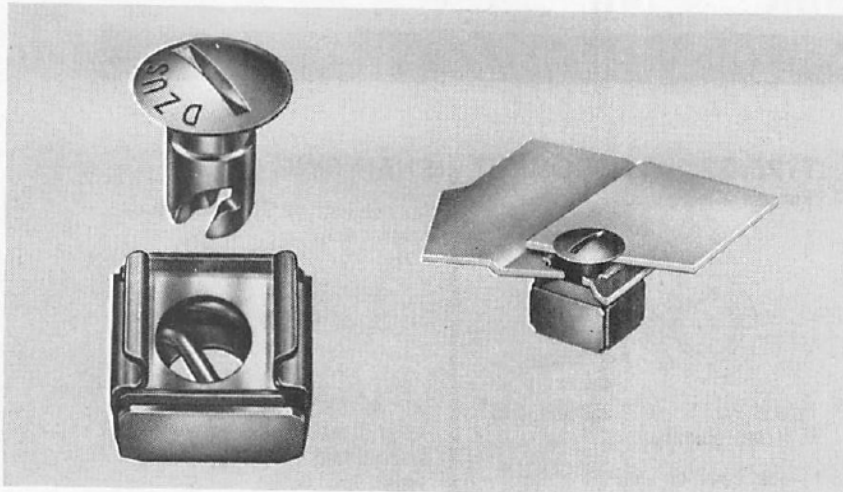

The SQC4 receptacle features compact size and fast installation, while providing all the advantages of DZUS spiral-cam ¼-turn fastening. Easily snapped into the underside of a square hole, it is self-retaining and it remains rattle-free whether the fastener is opened or locked.

In many cases, SQC4 can replace square hole caged nuts on existing equipment.

This is a highly durable fastener, with excellent strength for its small size.

### Technical Information

Working Tension: (Min)	11 lb
Safe Load without Distortion:	30 lb
Min. Distance between holes:	.50"
Constant Gap between Panel and Support face:	.02"

### RECEPTACLE

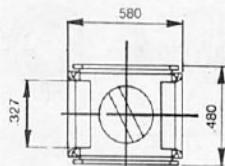

STUD HEAD SLOT ALIGNMENT IN LOCKED POSITION

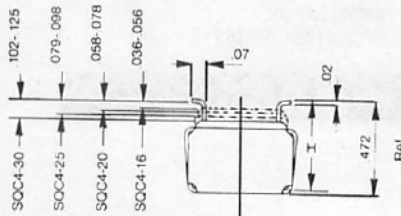

RECOMMENDED SPRING DEFLECTION: .020 to .045 H = .452

Material: All parts carbon steel, spring temper. Finish, all parts is bright zinc with yellow chromate dip per QQ-Z-325C Type II, Class 2.

### RECEPTACLE HOLE

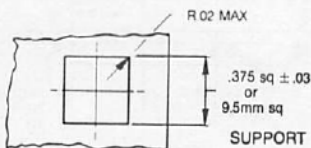

### RECEPTACLE SELECTION

Support Material Thickness	Receptacle Required
.031" — .056"	SQC4 — 16
.058" — .078"	SQC4 — 20
.079" — .098"	SQC4 — 25
.102" — .125"	SQC4 — 30

### STUD ASSEMBLY

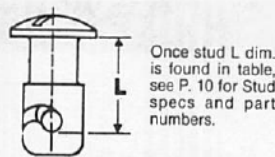
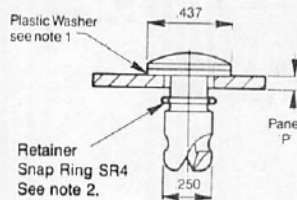

Once stud L dim. is found in table, see P. 10 for Stud specs and part numbers.

### STUD HOLE

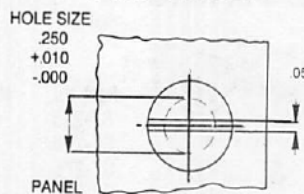

### STUD SELECTION

Panel Thickness	Stud ('L' Dim.)	GP4 Washer
.019-.043	-45 (.450)	None
.044-.068	-50 (.500)	One
.069-.093	-50 (.500)	None
.094-.118	-55 (.550)	One
.119-.143	-55 (.550)	None
.144-.168	-60 (.600)	One
.169-.193	-60 (.600)	None
.194-.218	-65 (.650)	One
.219-.243	-65 (.650)	None
.244-.268	-70 (.700)	One
.269-.293	-70 (.700)	None
.294-.318	-75 (.750)	One
.319-.343	-75 (.750)	None
.344-.368	-80 (.800)	One
.369-.393	-80 (.800)	None

### STUD LENGTH CALCULATION:

Add panel thickness, plus receptacle 'H' (.452). Select stud with 'L' dim. nearest to, but less than, that total. If stud 'L' dim is not at least .025 less than that total, add a GP4 plastic washer under the head to provide sufficient spring deflection.

Recommended spring deflection: .020 to .045

### NOTES:

- To provide correct locking tension, some studs are fitted with a .025 thick plastic washer under the head. Part GP4 offered for this use is not the same as stud retainer GP4B.
- The SR4 Snap Ring is the only standard stud retainer small enough to enter the SQC4 and allow flush contact between stud panel and receptacle clips.

### Installation

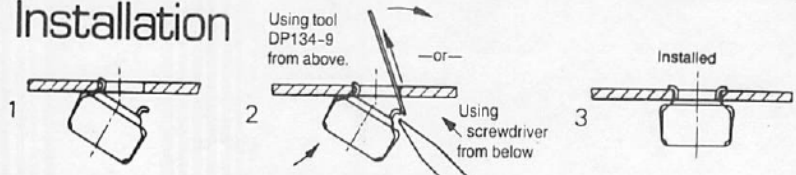

# SIZES 3 AND 4

## SEALED PRESS-IN RECEPTACLE

### SPS3 AND SPS4

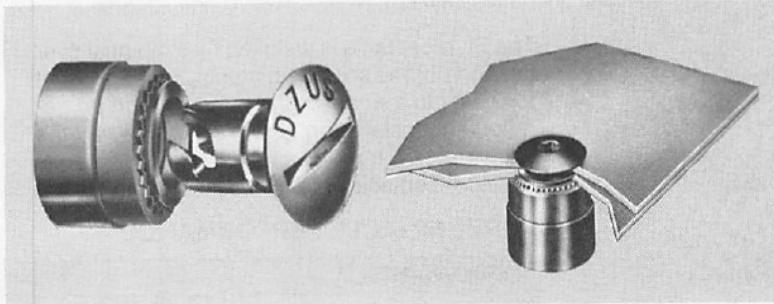

#### DIMENSIONS SPS3

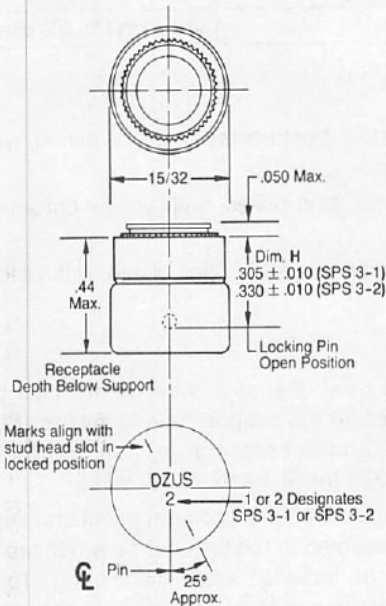

#### DIMENSIONS SPS4

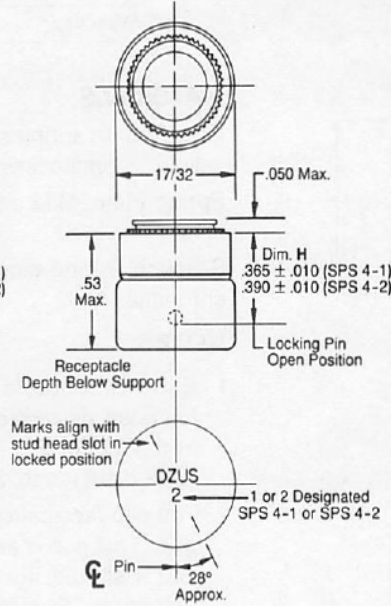

#### COMPONENT SELECTION

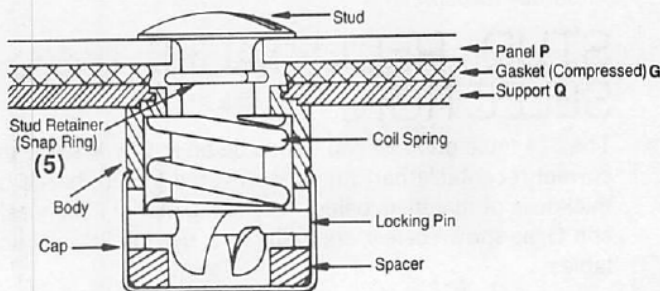

#### MATERIALS

- Body**—Alloy steel, Zinc plated.
- Cap**—Stainless steel, 300 series.
- Spacer**—Steel, Zinc plated.
- Coil Spring**—Stainless steel, 17-7 PH, spring temper.
- Locking Pin**—Stainless steel, 17-7 PH, spring temper.
- (5) Any stud retainer may be used, but only the SR snap ring can enter the receptacle aperture. The SR snap ring is the only retainer allowing panel to support contact, without requiring a nest in the panel underside to contain the retainer.

- **COMPACT SIZE**
- **SEALED AGAINST DUST AND EMI**
- **RUGGED 1/4-TURN ACTION**

The SPS receptacles pack a durable 1/4-turn action into a compact, sealed unit. The feel of their operating action is as crisp and solid as that of the most rugged aircraft types. Their sealed construction prevents metal dust from fastener action from entering the enclosure and is compatible with EMI barrier design.

#### SPECIFICATIONS

CHARACTERISTIC	SPS3	SPS4
Locking Tension	20 lb. at Nom. .033 Deflection	30 lb. at Nom. .040 Deflection
Locking Torque	2 to 6 in. lb.	4 to 10 in. lb.
Locking Stop Yield	30 in. lb.	50 in. lb.
Tensile Yield	45 lb.	60 lb.
Endurance	15,000 use cycles	15,000 use cycles

#### INSTALLATION

SPECIFICATIONS	SPS3	SPS4
Support hole dia. for receptacle	.312 +.003 -.000	.375 +.003 -.000
Minimum support thickness	.050	.050
Press-in pressure (1)	4500 lb.	4500 lb.
Push-out pressure (2)	300 lb.	300 lb.

- (1) In 2024T6 aluminum. Press-in force should be steady rather than a sharp blow. Use minimum pressure needed to fully seat receptacle shoulder against support, as determined by test. Do not exceed 6500 lb. pressure. Observe installation procedures normal for standard self-clinching nuts.
- (2) In 2024T6 aluminum.

MATERIAL THICKNESS P + G + Q	USE STUD DIM. L (3)	USE SPS3-
.050-.064	-35	-2
.065-.089	-35	-1
.090-.114	-40	-2
.115-.139	-40	-1
.140-.164	-45	-2
.165-.189	-45	-1
.190-.214	-50	-2
.215-.239	-50	-1
.240-.264	-55	-2
.265-.289	-55	-1
.290-.314	-60	-2
.315-.339	-60	-1
.340-.364	-65	-2
.365-.389	-65	-1
.390-.414	-70	-2
.415-.439	-70	-1
.440-.464	-75	-2
.465-.489	-75	-1

(3) Use any Standard Line size 3 stud style. See P. 8 for details.

MATERIAL THICKNESS P + G + Q	USE STUD DIM. L (4)	USE SPS4-
.035-.059	-40	-2
.060-.084	-40	-1
.085-.109	-45	-2
.110-.134	-45	-1
.135-.159	-50	-2
.160-.184	-50	-1
.185-.209	-55	-2
.210-.234	-55	-1
.235-.259	-60	-2
.260-.284	-60	-1
.285-.309	-65	-2
.310-.334	-65	-1
.335-.359	-70	-2
.360-.384	-70	-1
.385-.409	-75	-2
.410-.434	-75	-1
.435-.459	-80	-2
.460-.484	-80	-1

(4) Use any Standard Line size 4 stud style. See P. 10 for details.



Get quote

Angic Global Solutions

1-888-872-0690

19

<https://www.AngicGlobal.com> Sales@AngicGlobal.com

# FAST DZUS FASTENING

## SLIP-ON RECEPTACLE TYPE SL4, SL5

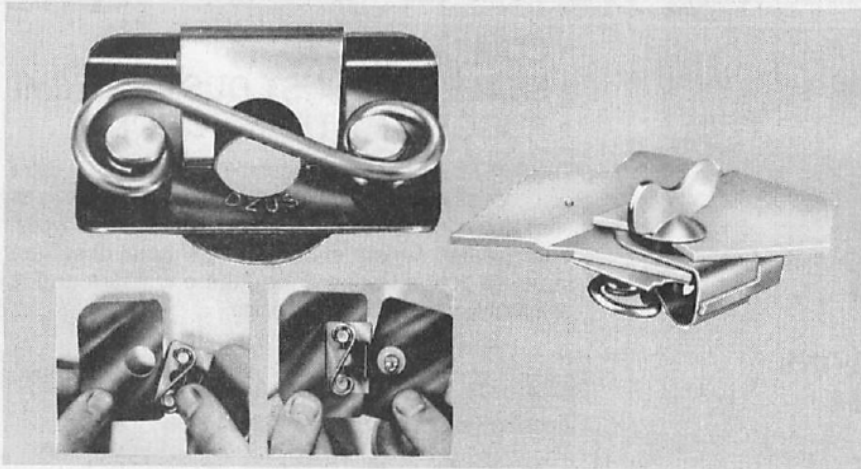

The SL receptacle is installed by slipping it over the edge of the support material and allowing it to snap into a single round hole. Support preparation and installation cost are very low, yet the SL offers performance equal to aircraft-type riveted receptacles of equal size.

### SL RECEPTACLE PERFORMANCE

PERFORMANCE	SL4	SL5
Locked service tension:	30 lb.	45 lb.
Max. tension without distortion:	60 lb.	85 lb.
Rated shear strength:	150 lb.	200 lb.
Wear life:	5000 uses	25,000 uses

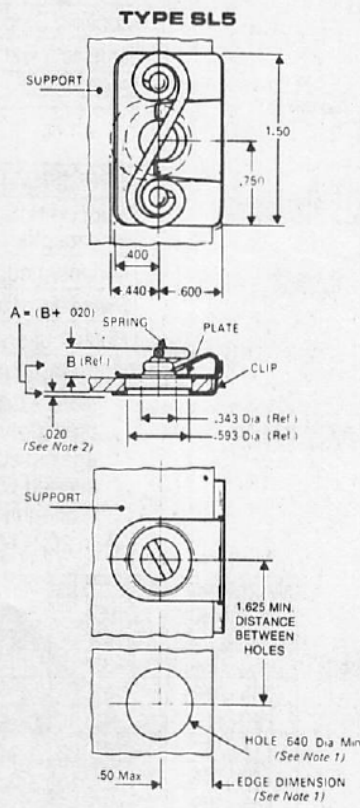
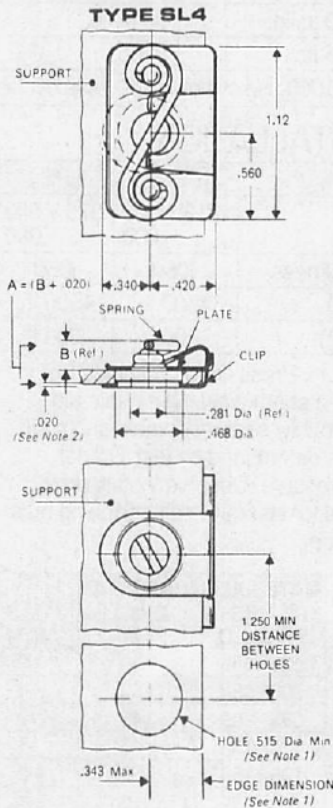

### MATERIALS:

Clip: Carbon spring steel, heat treated and zinc plated, with yellow chromate finish.

Spring Plate: Mild steel, zinc plated, with yellow chromate finish.

S-Spring: Spring-temper music wire, zinc plated, with yellow chromate finish.

### NOTES:

1. Extra receptacle float: Panel misalignment can be tolerated by increasing the support hole to .547 for SL4 and .703 for SL5, and decreasing the hole center to edge distance to .328 for SL4 and .450 for SL5.
2. The clip face causes a .020 gap between panel and support. This gap is assumed in the fastener selection table, and it should not be included when calculating "Total Thickness." Stud retainers enter clip and do not add to gap.
3. With stud locked to receptacle, S-spring deflection should be .024 to .050.

## STUD/RECEPTACLE SELECTION:

The SL4 table on P. 26 and SL5 table on P. 27 will show the correct receptacle part number and stud length, based on thickness of materials being fastened. Material thickness P and Q, as shown below, are required to use the SL selection tables.

Once stud length is determined, a complete stud part number can be derived from the specs for size 4 on P. 10 and for size 5 on P. 12.

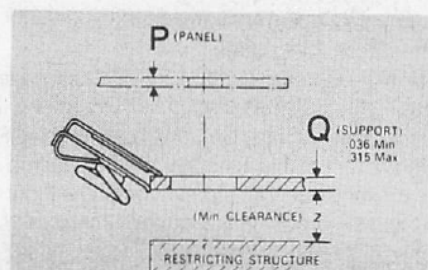

SL4 Part No.	A	B	Z min.
SL4-280			
SL4Y-280	.280	.260	.400
SL4X-280			
SL4-305			
SL4Y-305	.305	.285	.430
SL4X-305			

SL5 Part No.	A	B	Z min.
SL5-280			
SL5Y-280	.280	.260	.400
SL5X-280			
SL5-305			
SL5Y-305	.305	.285	.430
SL5X-305			
SL5-330			
SL5Y-330	.330	.310	.450
SL5X-330			
SL5-355			
SL5Y-355	.355	.335	.480
SL5X-355			



# 1/4-TURN GUIDE PIN FASTENERS

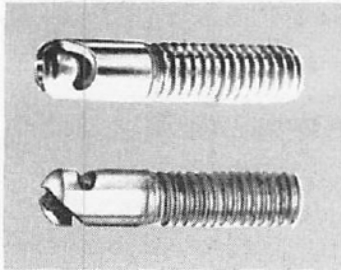

## STUDS, TYPE X936

Anchor-Cam 1/4-turn studs have threaded ends which may be anchored in blind holes with thread locking compound or secured to supports with lock-nuts. Once installed, the studs act as guide pins, aligning the panel for locking with Anchor-Cam Receptacles.

Different thread sizes and lengths are possible, on special order.

Material: Steel, heat treated and zinc plated with clear chromate finish.

NO. X936 1/4"-20 Thread, UNC-2A

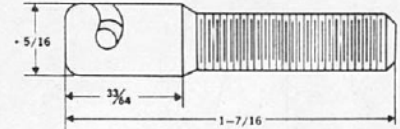

NO. X936A 5/16"-18 Thread, UNC-2A

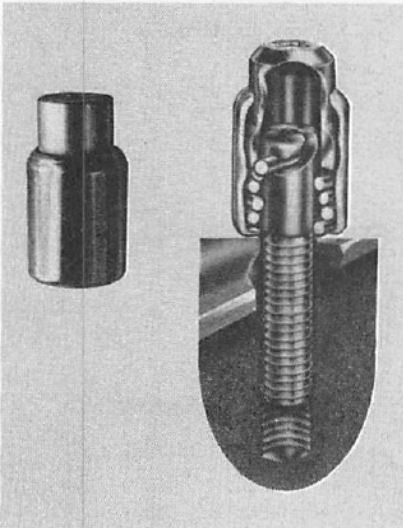
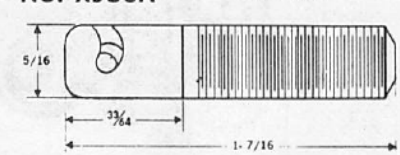

## RECEPTACLE, TYPE X935

The compact Anchor-Cam X935 receptacle is all stainless steel. It contains a heavy coil spring bridged by a cross-pin which engages the spiral cam in the stud end. The receptacle locks and releases in 1/4-turn. The receptacle head has a No. 3 Phillips recess.

Material: All stainless steel.

NO. X935

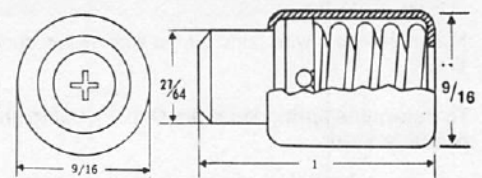

## DZUS "ANCHOR-CAM"—A High Strength, High Speed Fastener

Hold-down tension (per fastener)	60 lbs.
Receptacle locking torque	15 in. lbs.
Receptacle unlocking torque	10 in. lbs.
Rated tensile strength	500 lbs.
Ultimate tensile strength	1,000 lbs.

## "ANCHOR-CAM" DIMENSIONS AND INSTALLATION PROCEDURES

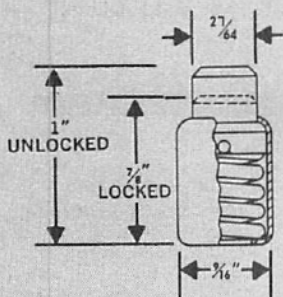

MINIMUM RECOMMENDED THREAD ENGAGEMENT IN THE BASE SECTION OF 3/8" LEAVES 3/16" AS MAX. THICKNESS OF REMOVABLE SECTIONS PLUS JAM NUT

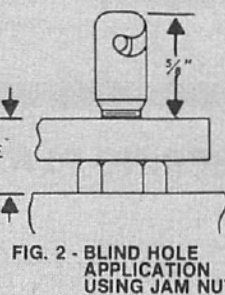
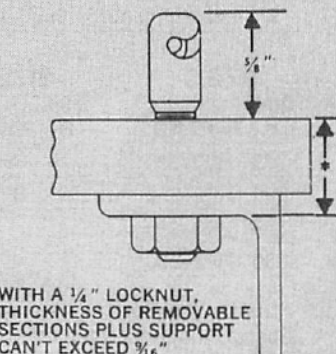
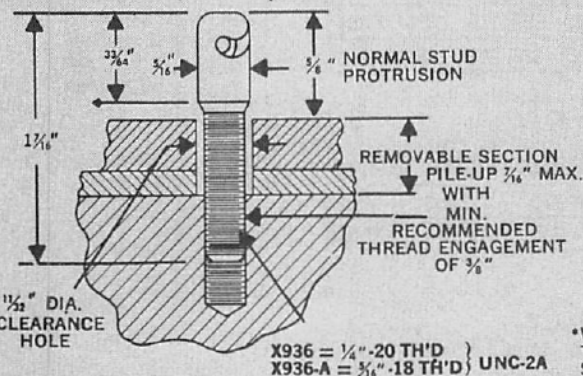

FIG. 2 - BLIND HOLE APPLICATION USING JAM NUT

A simple installation procedure requiring no measurement has been developed for blind hole applications where the stud is retained with locking compound:

1. FULLY ENGAGE STUD CAM ON RECEPTACLE CROSS-PIN
2. COAT THREADS WITH LOCKING COMPOUND
3. START STUD IN BOLT HOLE AND TURN DOWN TIGHT
4. TURN OUT ONE FULL TURN AND ALLOW LOCKING COMPOUND TO CURE



\*WITH A 1/4" LOCKNUT, THICKNESS OF REMOVABLE SECTIONS PLUS SUPPORT CAN'T EXCEED 3/16"

FIG. 1 - BLIND HOLE MOUNTING USING THREAD LOCKING COMPOUND



Get quote

Angic Global Solutions

1-888-872-0690

<https://www.AngicGlobal.com> Sales@AngicGlobal.com

**SIDE-MOUNTING  
 RECEPTACLE SPRINGS,  
 EJECTING BLADES**

**TYPES SB and SC**

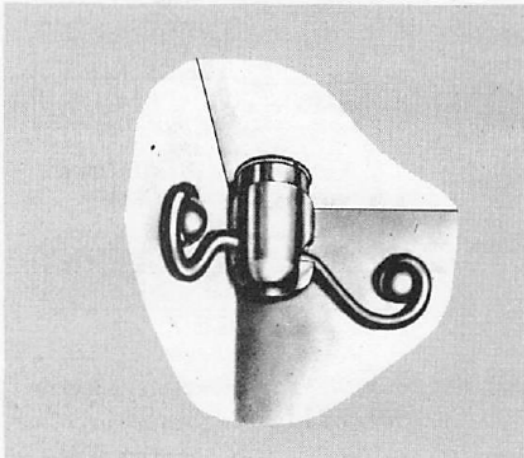

**Material:** Music wire, zinc plated with yellow chromate finish.

**To determine spring location (Dim. F), using shortest-possible stud:**

Usually it is desirable to have SB and SC springs as close to the stud as possible. To find minimum Dim. F:

1. Go to the stud selection table and find the shortest listed stud with an undercut length (Dim. B) able to contain the stud panel and stud retaining snap ring.
2. For that stud, find Dim. L in the table and subtract from it the thickness of the stud panel.
3. Add recommended spring deflection from the SB/SC table. This is the location of the spring rivet hole centers from the underside of the stud panel (Dim. F).

**NOTE:** Absolute F Min. = C + .016".

Dim. F can also be set at any other location equal to Dim. L of any stud, minus stud panel thickness, plus recommended spring deflection.

**SIZES 3, 4, 5**

These side-mounted springs may be used where there is no support beneath the stud.

Type SB spring rivets to support perpendicular to stud panel. Type SC spring rivets to box corner.

**NOTE:** Because there is no receptacle hole to guide the stud, stud panel should be registered, as with edge lip or hinge, to ensure stud will engage spring.

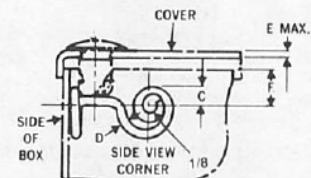
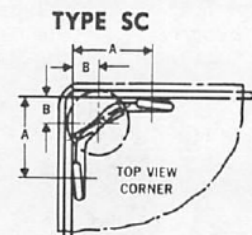
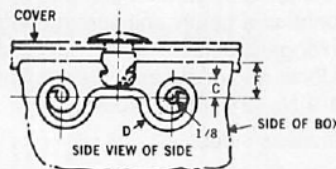
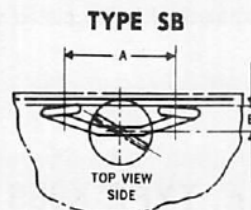

Stud selection: Size 3, P. 8; Size 4, P. 10; Size 5, P. 12.

Spring Part No.	A	B	C	D	Spring Wt. Lbs.	Recommended Spring Deflection
SB3-2*	11/16	1/8	3/32	.045	.0013	.040
SC3-2*	17/32	7/32	3/32	.045	.0013	.040
SB4-2	15/16	5/32	9/64	.062	.0028	.045
SC4-2	11/16	1/4	9/64	.062	.0029	.045
SB5-2	1	7/32	5/32	.080	.0046	.047
SC5-2	.700	7/32	5/32	.080	.0046	.047

\*SB3-2 and SC3-2 Springs have 3/32 rivet holes. Others have 1/8" rivet holes.

**RIGHT-ANGLE SPRING PLATES**

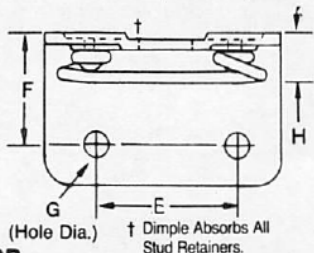
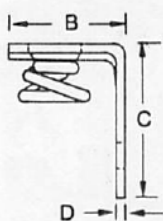
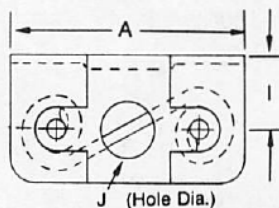
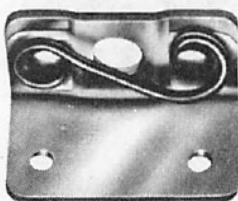

**Type: RP**

SIZE	A	B	C	D	E	F	G	I	J
3	1.125	.500	.625	.032	.625	.438	.128	.313	7/32
4	1.250	.625	.750	.050	.750	.563	.128	.375	9/32
5	1.625	.750	.875	.062	1.125	.625	.159	.438	11/32

**SIZE 3**

DIM. H	PART NO.
.205	RP3-205
.230	RP3-230
.255	RP3-255
.280	RP3-280

**SIZE 4**

DIM. H	PART NO.
.275	RP4-275
.300	RP4-300

**SIZE 5**

DIM. H	PART NO.
.285	RP5-285
.310	RP5-310
.335	RP5-335
.360	RP5-360

**MATERIALS**

Plate: No plate\* or zinc plate with yellow chromate  
 Spring: Music wire, zinc plated, with yellow chromate dip

\*To order plates bare (no zinc on plate) add 'H' to end of Part No. (Ex.: RP3-205 H).

To select proper H dim. and stud length, refer to Type RP Tables on p.p. 26 and 27.

# FULL GROMMETS



## TYPE GA AND GF GROMMET LENGTH SELECTION



**SIZE 3**  
SPECIFICATIONS ON P. 9

PANEL 'P' THICKNESS	GA FULL GROMMET	GF FULL GROMMET
.015 — .025	GA3-175	NOT AVAILABLE
.026 — .050	GA3-200	
.051 — .094*	GA3-250	

**SIZE 4**  
SPECIFICATIONS ON P. 11

PANEL 'P' THICKNESS	GA FULL GROMMET	GF FULL GROMMET
.015 — .025	GA4-225	GF4-125
.026 — .050	GA4-250	GF4-150
.051 — .075	GA4-275	GF4-175
.076 — .100*	GA4-300	GF4-200

**SIZE 5**  
SPECIFICATIONS ON P. 13

PANEL 'P' THICKNESS	GA FULL GROMMET	GF FULL GROMMET
.031 — .062	GA5-312	GF5-175
.063 — .094	GA5-350	GF5-225
.095 — .125*	GA5-375	GF5-250

**SIZE 6**  
SPECIFICATIONS ON P. 15

PANEL 'P' THICKNESS	GA FULL GROMMET	GF FULL GROMMET
.040 — .065	GA6-350	GF6-218
.066 — .100	GA6-375	GF6-250
.101 — .135*	GA6-425	GF6-300

**SIZE 7**  
SPECIFICATIONS ON P. 17

PANEL 'P' THICKNESS	GA FULL GROMMET	GF FULL GROMMET
.050 — .095	GA7-375	GF7-250
.096 — .156	GA7-475	GF7-325
.157 — .218*	GA7-525	GF7-400

\*For thicker panels, select type GSA or GSF grommet/stud assemblies.  
Installation instructions on PP. 29 and 32.

## TYPE GSA AND GSF THICK PANEL GROMMETS

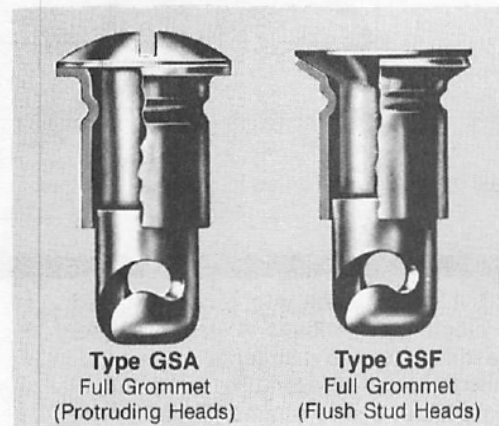

MATERIAL: Ductile Aluminum.

Type GSA and GSF thick panel grommets are supplied attached to their studs. The bead securing the grommet to the stud is close to the head to allow maximum retraction of the stud end into the panel. These grommets are offered in standard lengths, matching common panel thicknesses with ends extended beyond the panel, for retention by flaring. Other lengths are available on special order.

### STUD/GROMMET ASSEMBLY CALLOUT:

- 1 Determine stud length as directed by instructions provided for selected receptacle.
- 2 GSA or GSF grommet length (dim. T) is equal to panel thickness (dim. P) plus the grommet end flaring allowance.
- 3 The stud grommet assembly is called out by first stating the stud part number, followed by "T", followed by the grommet's T dim. in thousandths of an inch. EXAMPLE: AJ4-50T250

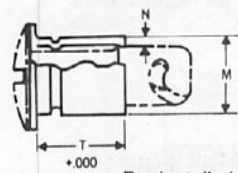
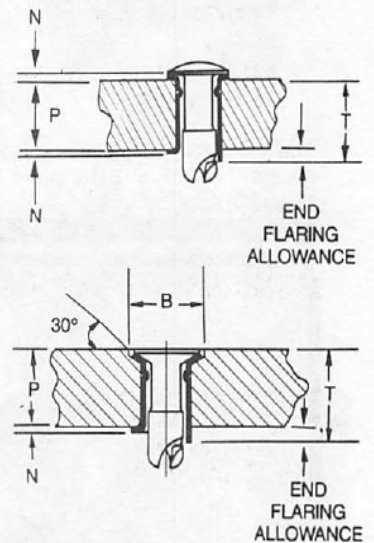

**Type GSA**  
Attached to any Stud but Flush Head

For installation, see Page 29.

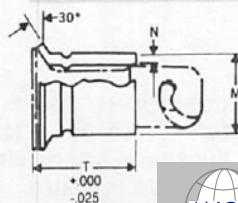

**Type GSF**  
Attached to Flush Head Stud

For installation,

GROMMET SIZE	DIM. M	DIM. N	DIM. B (FLUSH) HEAD	END FLARING ALLOWANCE
3	7/32	.015	21/64	.050
4	5/16	.025	29/64	.075
5	3/8	.028	37/64	.100
6	7/16	.028	45/64	.100
7	17/32	.040	49/64	.125

GSA 3 or GSF 3

PANEL 'P'	DIM. 'T'
.250	T300
.375	T425
.500	T575
.625	T700
.750	T825

GSA 4 or GSF 4

PANEL 'P'	DIM. 'T'
.375	T450
.500	T575
.625	T700

GSA 5 or GSF 5

PANEL 'P'	DIM. 'T'
.375	T475
.500	T600
.625	T725
.750	
.875	

GSA 6 or GSF 6

PANEL 'P'	DIM. 'T'
.500	T600
.625	T725
.750	T850

GSA 7 or GSF 7

PANEL 'P'	DIM. 'T'
.500	T625
.625	T750
.750	T875



Get quote

Angic Global Solutions

1-888-872-0690

<https://www.AngicGlobal.com> [Sales@AngicGlobal.com](mailto:Sales@AngicGlobal.com)

# FAST DZUS FASTENING

## SELF-EJECTING 1/4-TURN TYPE EHF TYPE SE

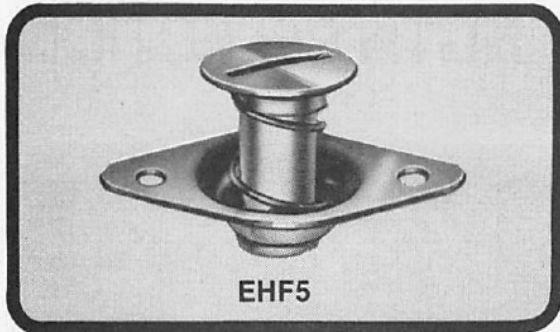

Dzus EHF5 stud assemblies are sold with stud and ejector spring secured in the mounting plate. The plate is riveted to the top of the removable panel, providing an advantage on weak materials by spreading stud tensile load. The extreme ejection on EHF 5 studs is a special advantage on curved or sliding panels.

Material: Stud, steel heat treated and zinc plated. Retaining plate steel, zinc plated. Spring, stainless steel 300-series. Plating, zinc with clear chromate finish.

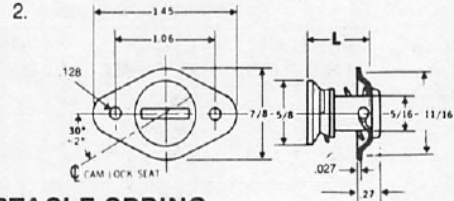

STUD NO.	STUD DIM. 'L'	STUD WEIGHT (LBS.)
EHF5-40	.400"	.0150
EHF5-50	.500"	.0179
EHF5-60	.600"	.0204

### COMPONENTS SELECTION / RIVETED RECEPTACLE SPRING

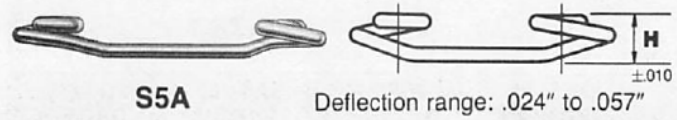

### TYPICAL INSTALLATION

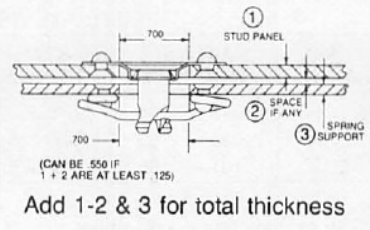

SPRING NO.	SPRING DIM. 'H'
S5A-200	.200"
S5A-225	.225"
S5A-250	.250"
S5A-275	.275"

TOTAL THICKNESS	USE STUD EHF5-	WITH SPRING S5A-
.120 THRU .149	-40	-275
.150 .174	-40	-250
.175 .199	-40	-225
.200 .224	-40	-200
.225 .249	-50	-275
.250 .274	-50	-250
.275 .299	-50	-225
.300 .324	-50	-200
.325 .349	-60	-275
.350 .374	-60	-250
.375 .399	-60	-225
.400 .424	-60	-200

S5A receptacle springs are riveted to the support. See P. 13 for complete specs. The EHF5 stud end dia. is larger than other size 5 studs, which limits compatible receptacles to S5A and X945 weld plate, shown below. Spring Material: Music wire zinc plated with yellow chromate finish.

### COMPONENTS SELECTION / WELD PLATE RECEPTACLE

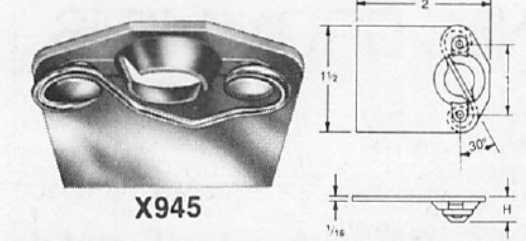

### TYPICAL INSTALLATION

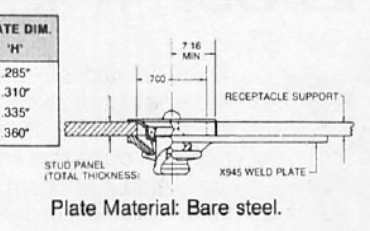

WELD PLATE NO.	PLATE DIM. 'H'
X945-285	.285"
X945-310	.310"
X945-335	.335"
X945-360	.360"

TOTAL THICKNESS	USE STUD EHF5-	WITH PLATE X945-
.032 THRU .064	-40	-360
.065 .089	-40	-335
.090 .114	-40	-310
.115 .139	-40	-285
.140 .164	-50	-360
.165 .189	-50	-335
.190 .214	-50	-310
.215 .239	-50	-285
.240 .264	-60	-360
.265 .289	-60	-335
.290 .314	-60	-310
.315 .339	-60	-285

The X945 weld plate has a stud entry hole especially designed to accept the EHF 5. Extra plate length permits bending to fit a variety of applications.

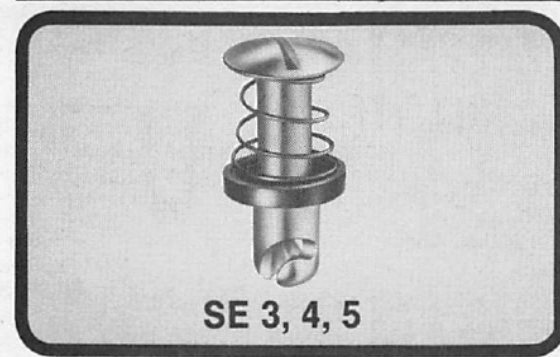

Standard Line studs in Sizes 3, 4, and 5, each in a variety of head styles, may be ordered as SE ejecting assemblies. A stainless steel ejecting spring and a black plastic cup are sold attached to the stud. Type SE ejection is partial, being limited by the length of stud undercut not occupied by the cup, panel, and stud retainer. Ejection will normally be sufficient to give a visual cue of an unlocked stud. Also, ejecting spring tension holds an opened stud firmly, easing removal and replacement of vertical panels and panels with multiple fasteners.

Type SE ejecting stud assemblies are compatible with all receptacles in their size.

Callout: Add Suffix **SE** to basic stud Part No. (Example: AJ4-60 SE).

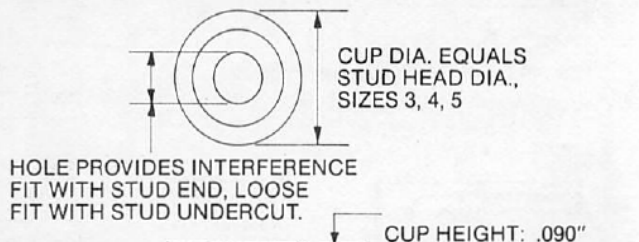
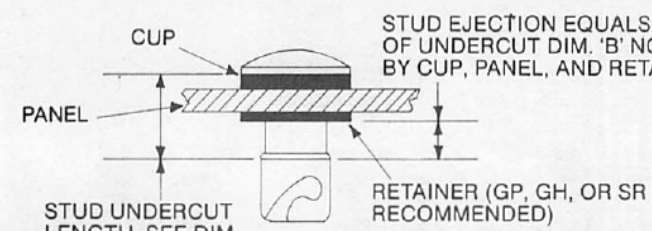

COMPLETE SPECS ON STUDS AND STUD RETAINERS: SIZE 3, P. 8; SIZE 4, P. 10; SIZE 5, P. 12.

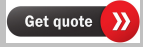

STUD VARIATIONS

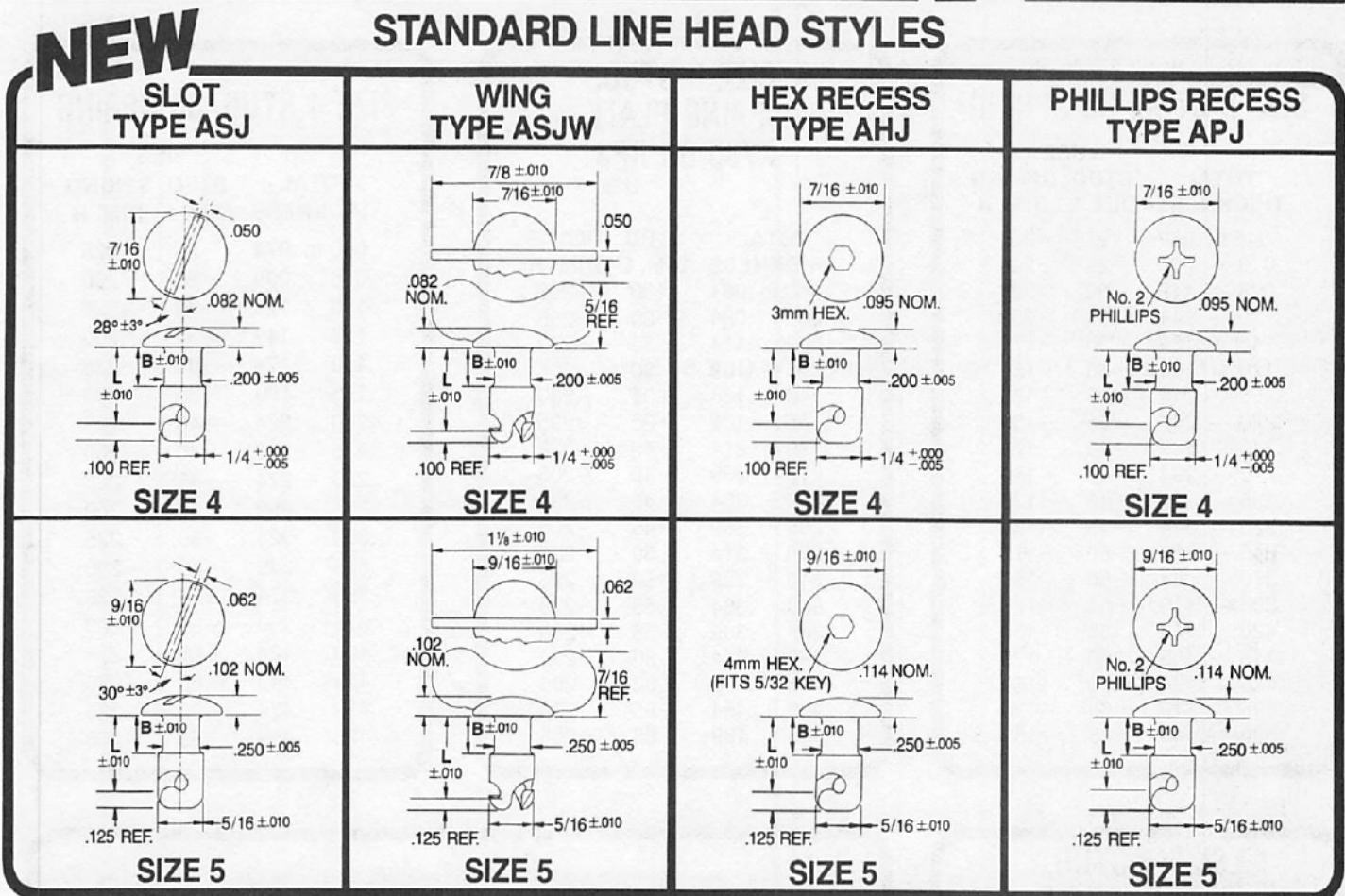

**SIZE 4**

L CALLOUT	L DIM.*	B DIM.*
-35	.350	.150
-40	.400	.200
-45	.450	.225
-50	.500	.250
-55	.550	.275
-60	.600	.300

**SIZE 5**

L CALLOUT	L DIM.*	B DIM.*
-30	.300	.125
-40	.400	.190
-50	.500	.250
-60	.600	.300

**MATERIAL**  
 Hardened carbon steel

**FINISHES**

- Bright zinc plate with clear chromate surface. Called out by basic part number.
- Bright zinc plate with black chromate surface. Add suffix **ZBB** to basic part number.

**STUD SELECTION**  
 Below their heads, dimensions of these new head styles are the same as for the traditional styles of equal size and L dimension. The new styles may be substituted for the equivalent traditional styles in the selection tables for stud attachments and stud/receptacle combinations.

**PERFORMANCE**  
 Performance data for these new head styles are the same as tabulated for the traditional styles in sizes 4 and 5 on P. 6 of the catalog.

\*L and B dimensions not tabulated may be available on special order, in minimum quantity of 50,000 pieces.

**PART NUMBERS** Start with head type, then size, then dash (-), then L callout, then finish suffix.  
 Ex.: AHJ5-40ZBB (Finish is black chromate over bright zinc). ASJ4-60. (Finish is clear chromate over bright zinc).

**SPECIAL STUDS**  
 Above the cam end of Standard Line studs, many design variations are possible. Some typical examples of past special designs are shown here. We invite your correspondence on special requirements.

**FASTENER ENDS** **SPECIAL WINGS** **NO UNDERCUT** **KNURLED HEAD**

**SIZE 3 STUD, S3 SPRING**

TOTAL THICKNESS	USE	
	STUD DIM. L	SPRING DIM. H
.045 to .069	-25	-225
.070 — .094	-25	-200
.095 — .119	-30	-225
.120 — .144	-30	-200
.145 — .169	-30	-175
.170 — .194	-30	-150
.195 — .219	-35	-175
.220 — .244	-35	-150
.245 — .269	-40	-175
.270 — .294	-40	-150
.295 — .319	-45	-175
.320 — .344	-45	-150
.345 — .369	-50	-175
.370 — .394	-50	-150
.395 — .419	-55	-175
.420 — .444	-55	-150
.445 — .469	-60	-175
.470 — .494	-60	-150
.495 — .519	-65	-175
.520 — .544	-65	-150

**SIZE 3 STUD,  
 SPRING PLATE  
 X735 OR RP3  
 USE**

TOTAL THICKNESS	STUD DIM. L	PLATE DIM. H
.040 to .064	-30	-280
.065 .089	-30	-255
.090 .114	-30	-230
.115 .139	-30	-205
.140 .164	-35	-230
.165 .189	-35	-205
.190 .214	-40	-230
.215 .239	-40	-205
.240 .264	-45	-230
.265 .289	-45	-205
.290 .314	-50	-230
.315 .339	-50	-205
.340 .364	-55	-230
.365 .389	-55	-205
.390 .414	-60	-230
.415 .439	-60	-205
.440 .464	-65	-230
.465 .489	-65	-205

**SIZE 4 STUD, S4 SPRING**

TOTAL THICKNESS	USE	
	STUD DIM. L	SPRING DIM. H
.050 to .074	-25	-225
.075 .099	-25	-200
.100 .124	-30	-225
.125 .149	-30	-200
.150 .174	-35	-225
.175 .199	-35	-200
.200 .224	-40	-225
.225 .249	-40	-200
.250 .274	-45	-225
.275 .299	-45	-200
.300 .324	-50	-225
.325 .349	-50	-200
.350 .374	-55	-225
.375 .399	-55	-200
.400 .424	-60	-225
.425 .449	-60	-200
.450 .474	-65	-225
.475 .499	-65	-200

**SIZE 4 STUD,  
 SPRING PLATE  
 X485 OR RP4  
 USE**

TOTAL THICKNESS	STUD DIM. L	PLATE DIM. H
.025 to .049	-30	-300
.050 .074	-30	-275
.075 .099	-35	-300
.100 .124	-35	-275
.125 .149	-40	-300
.150 .174	-40	-275
.175 .199	-45	-300
.200 .224	-45	-275
.225 .249	-50	-300
.250 .274	-50	-275
.275 .299	-55	-300
.300 .324	-55	-275
.325 .349	-60	-300
.350 .374	-60	-275
.375 .399	-65	-300
.400 .424	-65	-275
.425 .449	-70	-300
.450 .474	-70	-275

**SIZE 4 STUD, SL4 RECEPTACLE**

To Use Chart:	TOTAL THICKNESS P + Q	USE ANY SIZE 4 STUD DIM. L	USE RECEPTACLE SL4 —		
			If Q = .036 to .128	If Q = .130 to .220	If Q = .225 to .315
	.046 to .070	-30	-280		
	.071 .095	-35	-305		
	.096 .120	-35	-280		
	.121 .145	-40	-305		
	.146 .170	-40	-280	Y-280	
	.171 .195	-45	-305	Y-305	
	.196 .220	-45	-280	Y-280	
	.221 .245	-50	-305	Y-305	X-305
	.246 .270	-50	-280	Y-280	X-280
	.271 .295	-55	-305	Y-305	X-305
	.296 .320	-55	-280	Y-280	X-280
	.321 .345	-60	-305	Y-305	X-305
	.346 .370	-60	-280	Y-280	X-280
	.371 .395	-65	-305	Y-305	X-305
	.396 .420	-65	-280	Y-280	X-280
	.421 .445	-70	-305	Y-305	X-305
	.446 .470	-70	-280	Y-280	X-280
	.471 .495	-75	-305	Y-305	X-305
	.496 .520	-75	-280	Y-280	X-280

1. MEASURE YOUR TOTAL THICKNESS . . . Total thickness = stud panel 'P' + receptacle support 'Q' + grommet thickness, if any, between stud head and panel. Do not include SL receptacle thickness.

2. SELECT STUD LENGTH AND SL RECEPTACLE . . . Find your total thickness in far-left column. Use stud length (any style) from next column to right. Use receptacle from column that includes your support thickness 'Q'. Full details on studs, P. 10.

SQC4 selection table on Page 18. SPS4 selection table on Page 19.

# SELECTION TABLES STUD LENGTH, RECEPTACLE DEPTH



### SIZE 5 STUD, S5A SPRING USE

TOTAL THICKNESS	STUD DIM. L	SPRING DIM. H
.055	.079	-30
.080	.104	-30
.105	.129	-30
.130	.154	-30
.155	.179	-40
.180	.204	-40
.205	.229	-40
.230	.254	-40
.255	.279	-50
.280	.304	-50
.305	.329	-50
.330	.354	-50
.355	.379	-60
.380	.404	-60
.405	.429	-60
.430	.454	-60
.455	.479	-70
.480	.504	-70
.505	.529	-70
.530	.554	-70

### SIZE 5 STUD, SL5 RECEPTACLE

TOTAL THICKNESS P + Q	USE ANY SIZE 5 STUD DIM. L	USE RECEPTACLE SL5 —		
		If Q = .036 to .128	If Q = .130 to .220	If Q = .225 to .315
.046 to .070	-30	-280		
.071 .095	-40	-355		
.096 .120	-40	-330		
.121 .145	-40	-305		
.146 .170	-40	-280	Y-280	
.171 .195	-50	-355	Y-355	
.196 .220	-50	-330	Y-330	
.221 .245	-50	-305	Y-305	X-305
.246 .270	-50	-280	Y-280	X-280
.271 .295	-60	-355	Y-355	X-355
.296 .320	-60	-330	Y-330	X-330
.321 .345	-60	-305	Y-305	X-305
.346 .370	-60	-280	Y-280	X-280
.371 .395	-70	-355	Y-355	X-355
.396 .420	-70	-330	Y-330	X-330
.421 .445	-70	-305	Y-305	X-305
.446 .470	-70	-280	Y-280	X-280
.471 .495	-80	-355	Y-355	X-355
.496 .520	-80	-330	Y-330	X-330

To Use Chart:  
 1. MEASURE YOUR TOTAL THICKNESS . . . Total thickness = stud panel 'P' + receptacle support 'Q' + grommet thickness, if any, between stud head and panel. Do not include SL receptacle thickness.  
 2. SELECT STUD LENGTH AND SL RECEPTACLE . . . Find your total thickness in far left column. Use stud length (any style) from next column to right. Use receptacle from column that includes your support thickness 'Q'. Full details on studs, P. 12.

### SIZE 5 STUD, SPRING PLATE X414 OR RP5 USE

TOTAL THICKNESS	STUD DIM. L	PLATE DIM. H
.040 to .064	-30	-285
.065 .089	-40	-360
.090 .114	-40	-335
.115 .139	-40	-310
.140 .164	-40	-285
.165 .189	-50	-360
.190 .214	-50	-335
.215 .239	-50	-310
.240 .264	-50	-285
.265 .289	-60	-360
.290 .314	-60	-335
.315 .339	-60	-310
.340 .364	-60	-285
.365 .389	-70	-360
.390 .414	-70	-335
.415 .439	-70	-310
.440 .464	-70	-285
.465 .489	-80	-360
.490 .514	-80	-335

### SIZE 6 STUD, S6A SPRING AND SIZE 7 STUD, S7 SPRING USE

TOTAL THICKNESS	STUD DIM. L	SPRING DIM. H
.090 to .114	-35	-300
.115 .139	-35	-275
.140 .164	-40	-300
.165 .189	-40	-275
.190 .214	-40	-250
.215 .239	-40	-225
.240 .264	-50	-300
.265 .289	-50	-275
.290 .314	-50	-250
.315 .339	-50	-225
.340 .364	-60	-300
.365 .389	-60	-275
.390 .414	-60	-250
.415 .439	-60	-225
.440 .464	-70	-300
.465 .489	-70	-275
.490 .514	-70	-250
.515 .539	-70	-225

### SIZE 6 STUD, X441 WELD PLATE AND SIZE 7 STUD, X442 WELD PLATE USE

TOTAL THICKNESS	STUD DIM. L	PLATE DIM. H
.055 to .079	-40	-385
.080 .104	-40	-360
.105 .129	-40	-335
.130 .154	-40	-310
.155 .179	-50	-385
.180 .204	-50	-360
.205 .229	-50	-335
.230 .254	-50	-310
.255 .279	-60	-385
.280 .304	-60	-360
.305 .329	-60	-335
.330 .354	-60	-310
.355 .379	-70	-385
.380 .404	-70	-360
.405 .429	-70	-335
.430 .454	-70	-310
.455 .479	-80	-385
.480 .504	-80	-360
.505 .529	-80	-335
.530 .554	-80	-310

NOTE: If using FLUSH HEAD STUDS WITH DIMPLED SUPPORT, dimple may interfere with lowest receptacle spring in each table. Consult your distributor for lowest cost stud for your application.



Get quote »

Angic Global Solutions 1-888-872-0690  
<https://www.AngicGlobal.com> Sales@AngicGlobal.com

WITH STUD RETAINERS: GP PUSH-ON GROMMET • SR PUSH-ON SPLIT RING  
 GH FLATTENED HALF-GROMMET • SX RETAINING SPRING

**STUD PANEL PREPARATION**

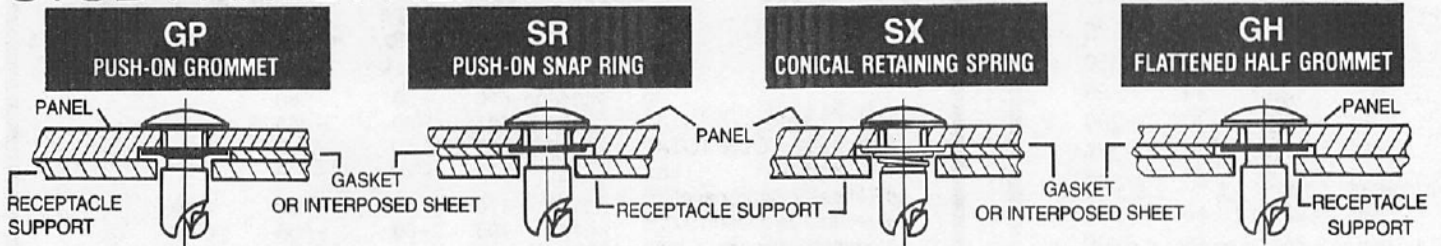

All these stud retention method drawings show the stud retainer absorbed either by a panel hole counterbore or by thickness of a sheet between panel and support. If neither option can be used, then retainer thickness

can also be absorbed by the support thickness, or by the receptacle itself (using an SL or RP, or an SQC or SPS with SR split retainer).

**STANDARD PANEL HOLE**

Stud Size	Hole Dia. +.010 - .000
3	3/16
4	1/4
5	5/16
6	3/8
7	7/16

**OVERSIZE PANEL HOLE**

Stud Size	Hole Dia. +.010 - .000
3	7/32
4	5/16
5	3/8
6	7/16
7	1/2

Using GP or GH grommet, an oversize panel hole allows stud to float, to compensate for panel-support misalignment—not for use with SR split ring retainers—

**GASKET OR INTERPOSED SHEET HOLE**

This hole should be sufficiently larger than the stud retainer outside diameter to allow free entry of the retainer.

**STUD RETAINER INSTALLATION**

**FRST HAND TOOL** spreads inside diameter of retainers over stud shanks and pushes them into stud undercuts.

**BLOCK #1** Nests stud head during installation (any flat block may be used for BJR ring head studs).

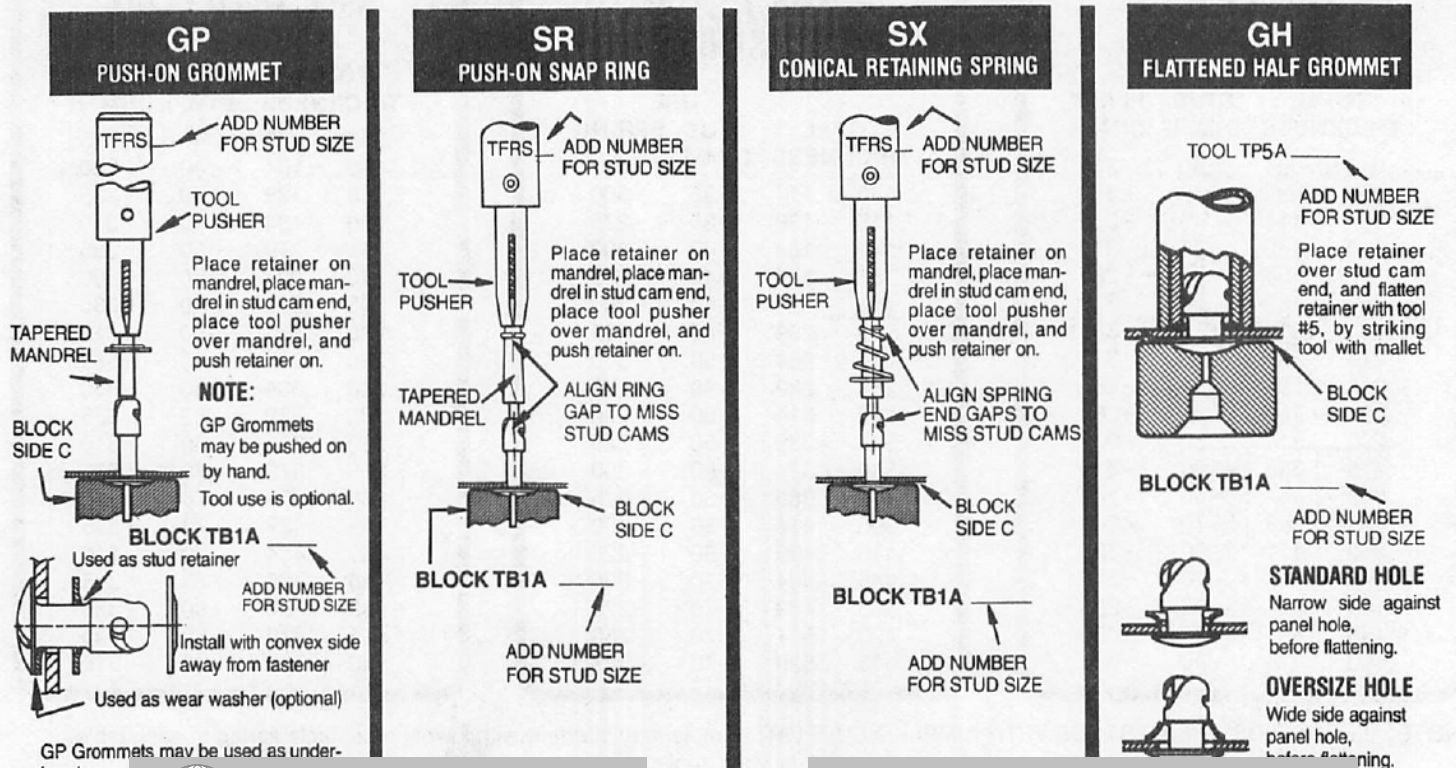

**STUD INSTALLATION,  
 ALL HEAD STYLES  
 EXCEPT FLUSH**

**WITH STUD RETAINERS: GA FULL GROMMET  
 GSA THICK PANEL GROMMET**

**WITH STUD RETAINER GA FULL GROMMET:  
 STUD PANEL PREPARATION**

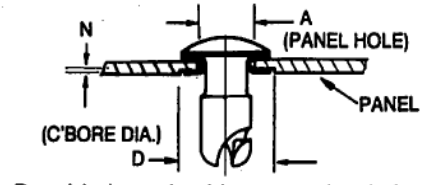
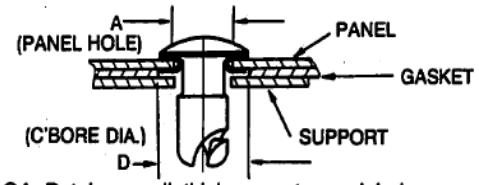

GA Retainer wall thickness at panel hole underside is absorbed by gasket or interposed panel at least as thick, or by dimpled support.

Panel hole underside counterbored to depth equal to GA Retainer wall thickness N.

STUD SIZE	DIM. A	DIM. D	DIM. N ±.005
3	7/32	11/32	.020
4	5/16	15/32	.030
5	3/8	19/32	.035
6	7/16	21/32	.035
7	17/32	25/32	.045

**STUD RETAINER INSTALLATION**

**(1) INSERT GROMMET IN PANEL HOLE**



**(2) SET GROMMET**

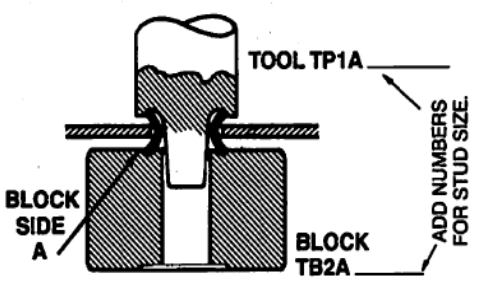

**(3) INSERT STUD**



**(4) CLINCH GROMMET**

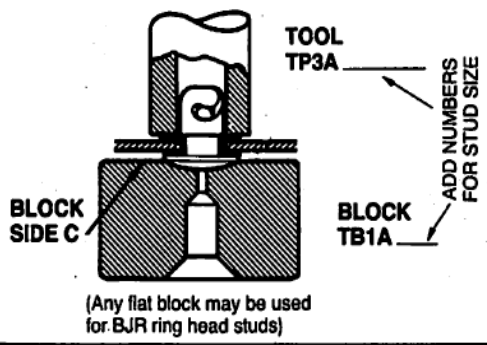

**STUD RETAINER REMOVAL**

An installed GA Grommet may be removed by shearing off its underside flange with a staking tool.

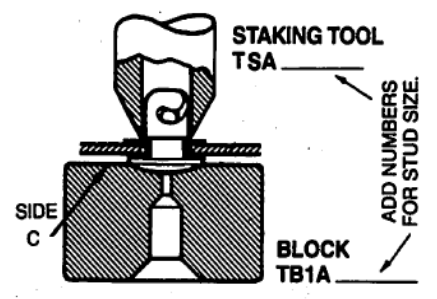

**WITH STUD RETAINER GSA THICK PANEL GROMMET:**

**STUD PANEL PREPARATION AND RETAINER INSTALLATION**

1. Make hole in panel for light press fit of grommet



GROMMET TYPE	HOLE DIA.
GSA3	7/32
GSA4	5/16
GSA5	3/8
GSA6	7/16
GSA7	17/32

2. Press Grommet

3. Flare Grommet using type TF flaring tool and Block TB1A (or surface plate) to support stud head.

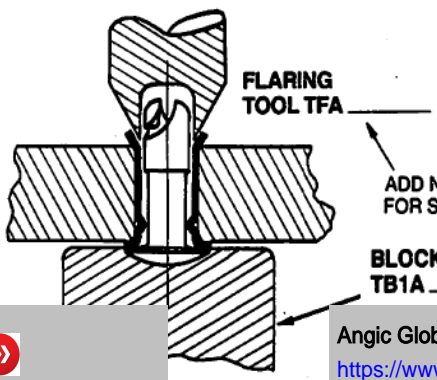

4. Flatten Grommet using Tool TP3A

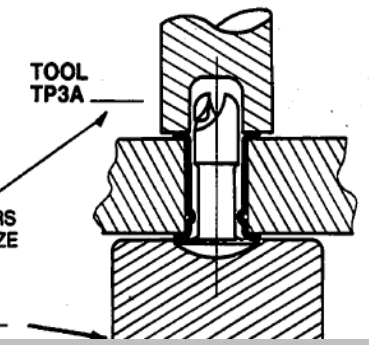

Get quote >>

# S-SPRING AND FLAT SPRING PLATE RECEPTACLE INSTALLATION, ALL HEAD STYLES EXCEPT FLUSH:

## SUPPORT PREPARATION FOR S-SPRING RECEPTACLE

### A. With stud retainer recessed in panel underside:

#### (1) MAKE SUPPORT HOLES FOR STUD AND RIVETS

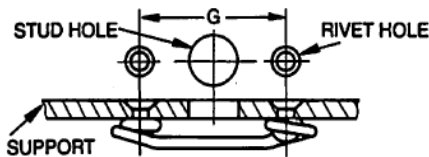

SPRING SIZE	SPRING DWG. PAGE	STUD HOLE DIA.	DIM. G. ±.002"	RIVET HOLE DIA.	* RIVET HOLE COUNTERSINK	RIVET SHANK DIA.
3	9	7/32	.625	.097 to	3/16 DIA. X 110°	3/32
4	11	9/32	.750	.100		
5	13	11/32	1.000	.129 to	1/4 DIA. X 110°	1/8
6	15	13/32	1.375	.133		
7	17	15/32	1.438			

\*Assuming use of solid rivets

#### (2) SECURE RECEPTACLE TO SUPPORT

### B. With stud retainer recessed in support (support thin enough to be dimpled):

#### (1) MAKE SUPPORT HOLES FOR STUD AND RIVETS

Hole centers and rivet holes are as shown in table above. Use stud hole diameters as shown in table below.

STUD SIZE	MAX. SUPPORT THICKNESS FOR DIMPLING	STUD HOLE DIA.
3	.040	3/16
4	.050	1/4
5	.063	5/16
6	.078	3/8
7	.078	7/16

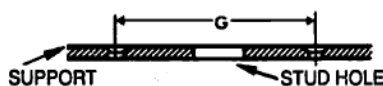

#### (2) DIMPLE SUPPORT

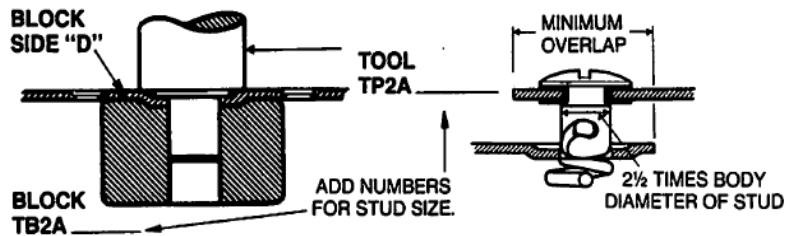

#### (3) SECURE RECEPTACLE TO SUPPORT



## SUPPORT PREPARATION FOR FLAT SPRING PLATE RECEPTACLE

### A. With Stud Retainer recessed in panel underside:

#### (1) MAKE STUD HOLE IN SUPPORT

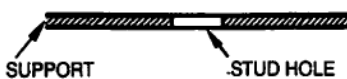

PLATE SIZE	HOLE DIA.
3	7/32
4	9/32
5	11/32
6	13/32
7	15/32

#### (2) SECURE RECEPTACLE TO SUPPORT

Receptacle may be held in position for welding by locking on a stud.



### B. With Stud Retainer recessed in support:

#### (1) MAKE STUD HOLE IN SUPPORT

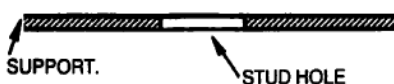

PLATE SIZE	STUD HOLE DIA.	
	IF USING GROMMET OR SX SPR.	IF USING SR RING
3	11/32	1/4
4	15/32	5/16
5	19/32	3/8
6	21/32	7/16
7	25/32	1 1/2

#### (2) SECURE RECEPTACLE TO SUPPORT



# STUD INSTALLATION, FLUSH HEADS

## WITH STUD RETAINER GF: PANEL PREPARATION

NOTE: Dimpled panels require dimpled supports.

(1) DRILL AND DIMPLE HOLE

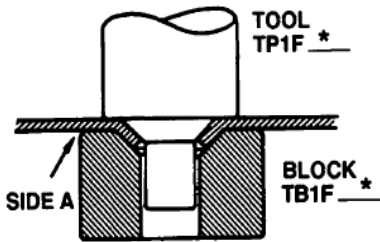

(2) INSERT GROMMET

Stud Size	Drilled Hole
4	17/64
5	5/16
6	3/8
7	15/32

(3) SET GROMMET

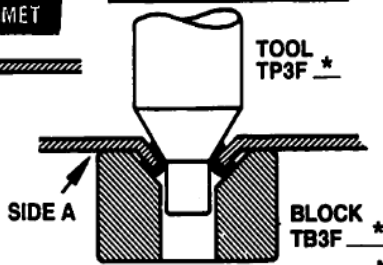

(4) INSERT AND CLINCH STUD

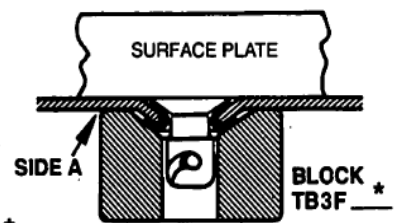

NOTE: GF Grommets can be removed with staking tool Type A.

\* ADD NUMBER FOR STUD SIZE

## WITH NO STUD RETAINER, REVERSE-CLINCHED HOLE: PANEL PREPARATION

(1) DRILL AND DIMPLE HOLE

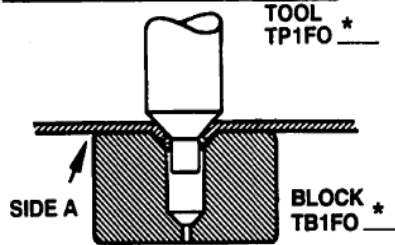

Stud Size	Drilled Hole	Max. Panel Thickness for Dimpling
3	9/64	.030
4	13/64	.040
5	15/64	.050
6	19/64	.078

(2) INSERT STUD



(3) CLINCH STUD

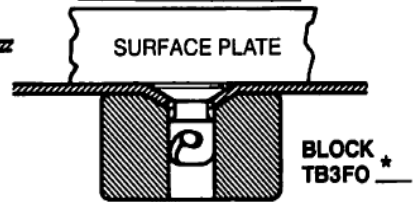

NOTE: Dimpled panels require dimpled supports.

\* ADD NUMBER FOR STUD SIZE

## WITH GP PUSH-ON GROMMET, SR PUSH-ON SPLIT RING, OR GH FLATTENED HALF GROMMET: PANEL PREPARATION

(1) DRILL AND COUNTERSINK HOLE

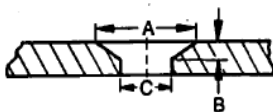

NOTE: This stud panel hole permits use of S-spring receptacle without dimpled stud hole in support.

Stud Size	DIM. A	DIM. B	DIM. C
	+ .010 - .000	+ .010 - .000	+ .010 - .000
3	.367	.051	.188
4	.508	.074	.250
5	.633	.092	.313
6	.757	.095	.375
7	.837	.110	.438

(2) INSTALL STUD RETAINER

See Stud Installation, Page 28, for installing these retainers.

Where there is enough material thickness, either the panel underside or the support top may be countersunk to absorb the retainer thickness.

## WITH STUD RETAINER, GSF: PANEL PREPARATION AND RETAINER INSTALLATION

(1) MAKE HOLE IN PANEL FOR LIGHT PRESS FIT OF GROMMET, COUNTERSINK & COUNTERBORE

(2) PRESS GROMMET STUD ASSEMBLY INTO HOLE

(4) FLATTEN GROMMET USING TYPE A TOOL #3

(3) FLARE GROMMET USING TYPE TF FLARING TOOL

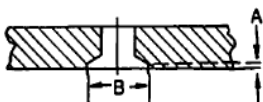

Grommet Type	Hole dia.	A dim.	B dim.
GSF 3	7/32	.030	21/64
GSF 4	5/16	.043	29/64
GSF 5	3/8	.045	37/64
GSF 6	7/16	.047	45/64
GSF 7	17/32	.063	49/64

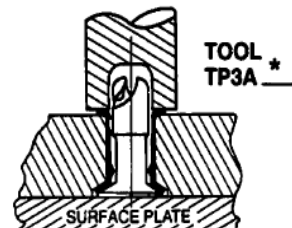
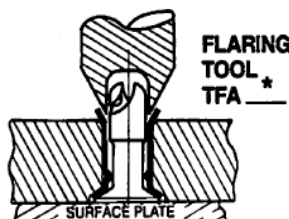

\* ADD NUMBER



Get quote

Angic Global Solutions

1-888-872-0690

<https://www.AngicGlobal.com> [Sales@AngicGlobal.com](mailto:Sales@AngicGlobal.com)

# S-SPRING RECEPTACLE INSTALLATION, FLUSH HEAD STUDS

## SUPPORT PREPARATION FOR S-SPRING RECEPTACLE

**A. WITH DIMPLED PANEL STUD HOLE AND GF GROMMET:**

**B. WITH DIMPLED AND REVERSE-CLINCHED PANEL STUD HOLE:**

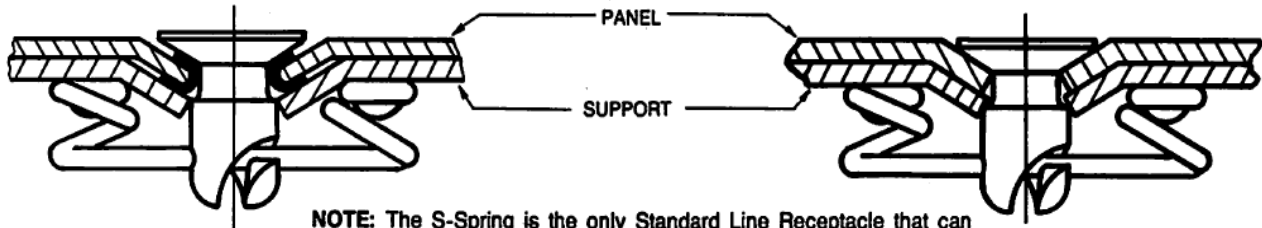

**NOTE:** The S-Spring is the only Standard Line Receptacle that can accept a dimpled support hole as shown here.

**(1) MAKE SUPPORT HOLES FOR STUD AND RIVETS.**

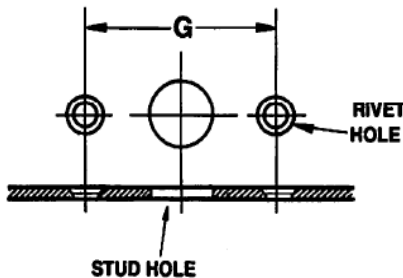

SPRING SIZE	SPRING DWG. PAGE	STUD HOLE DIA.	DIM. G ±.002	RIVET HOLE DIA.	* RIVET-HOLE COUNTERSINK	RIVET SHANK DIA.
3	9	3/16	.625	.097	3/16 DIA X 110°	3/32
4	14	1/4	.750	.100		
5	18	5/16	1.000	.129	1/4 DIA X 110°	1/8
6	15	3/8	1.375	.133		
7	17	7/16	1.438			

\*ASSUMING USE OF SOLID RIVETS

**(2) DIMPLE SUPPORT HOLE.**

**NOTE:** A panel stud hole dimpled for a GF Grommet requires a different support dimple than one dimpled and reverse-clinched with no Grommet.

**NOTE:** If stud panel hole is flat on underside and countersunk for stud head on top, support hole need not be dimpled. In this case, prepare support as shown for non-flush head studs.

**(3) SECURE SPRING TO SUPPORT.**



FOR PANEL HOLE A WITH GF GROMMET:

TOOL TP2F \*

FOR PANEL HOLE B WITH NO GROMMET:

TOOL TP2FO \*

SUPPORT

BLOCK TB2F \*

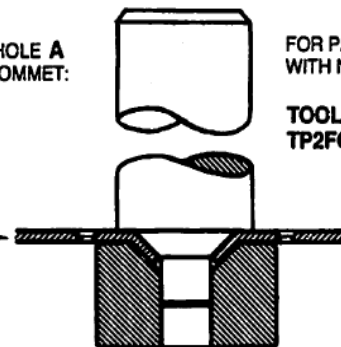

\* ADD NUMBER FOR STUD SIZE

## USE OF RECEPTACLES OTHER THAN S-SPRING

Using Flush Head Studs with any Standard Line receptacle other than the S-Spring requires that the panel stud hole be flat on the underside and countersunk for the stud head on top.

**Captive  
 1/4-Turn  
 Fasteners**  
 Continuous Receptacle Strip

MIL-F-25173A APPROVED

Dzus Panel Line features captive, flare-in stud assemblies and continuous receptacle strips with both stud and rivet holes on 3/8" centers.

The captive stud assemblies are offered in a range of neck lengths for flare-installation into standard gage enclosure panels.

The receptacle strips are installed to frame out the console opening, serving as offset supports for the stud panel. Continuous stud holes and installation rivet holes are available every 3/8".

1/4-turn fastening action offers operating convenience, predictable clamping force, and locked vibration resistance. Panel Line fasteners combine those features with the versatility of continuous and closely-spaced panel fastening points, and the ease of flare-in stud installation.

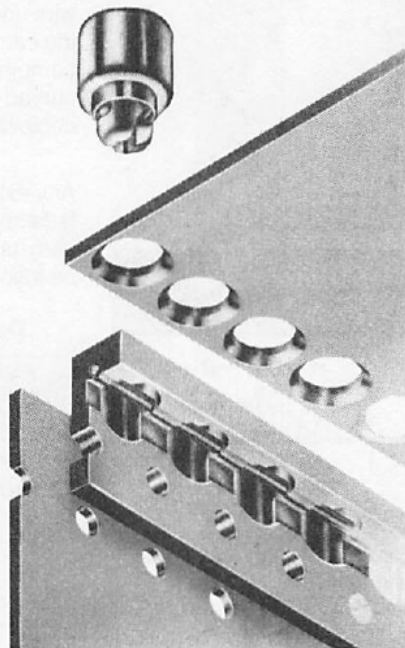
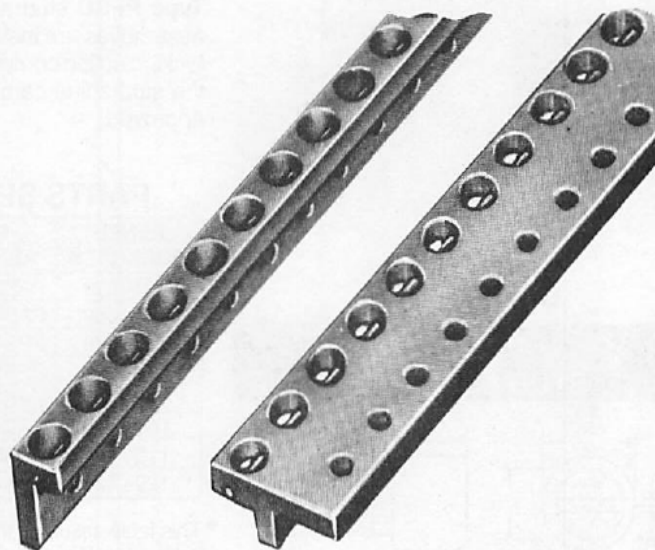
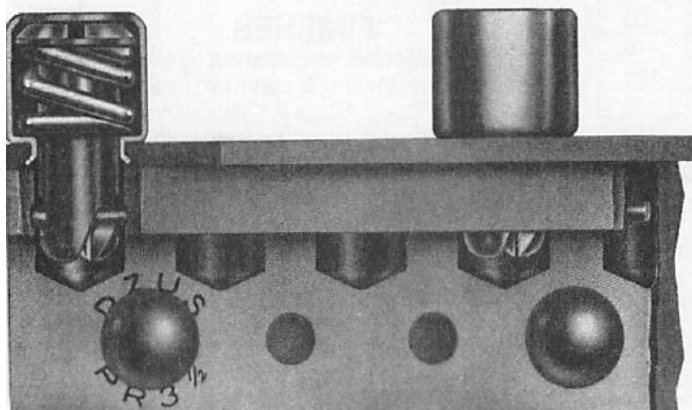

**NOTE** — The selection and installation planning of fasteners can influence the security of the fastened parts. Dzus product information and support service is intended for use only by persons with mechanical engineering qualifications sufficient to manage the responsibilities of:

1. Analyzing fastener performance in relation to the service to be met, and
2. Planning appropriate fastening locations and installations.

# FAST

# DZUS

# FASTENING

## STUD ASSEMBLIES

### TYPE PFSC35

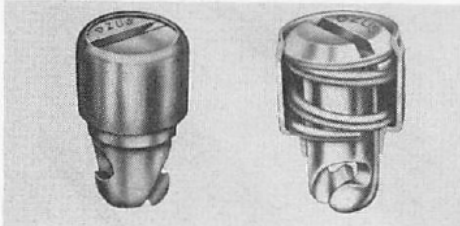

### DIMENSIONS

#### PFSC 35 STUD ASSEMBLY

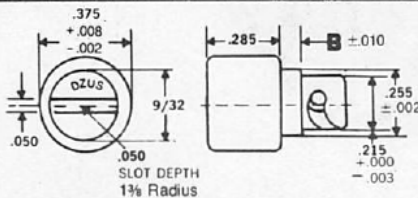

Type PFSC stud assemblies consist of a stud and coil spring captive in a steel cup. The assemblies are installed by flaring the end of the cup neck into a countersunk panel hole. Stud locking action compresses the spring, exerting a clamping force on the fastened parts. In locking, the stud spiral cam engages a rigid wire which is offered by the receptacle. MIL-F-25173A approved.

### PARTS SELECTION \*

PANEL THICKNESS	STUD ASSEMBLY	CUP DIM. B
.050-.059	PFSC35-37A	.070
.060-.069	PFSC35-38A	.080
.070-.079	PFSC35-39A	.090
.080-.089	PFSC35-40A	.100
.090-.099	PFSC35-41A	.110
.100-.109	PFSC35-42A	.120
.110-.119	PFSC35-43A	.130
.120-.129	PFSC35-44A	.140

\* This table assumes the locked stud panel will contact Dzus receptacle strip having a wire depth (Dim. H) of .150".

### SPECIFICATIONS

**Locking tension:** 15 lb.  
**Rated tensile and shear:** 200 lb. when used with Dzus receptacles.  
**Max. sheet separation under tensile overload:** 3/64"  
**Wear endurance:** 5000 use cycles

### MATERIALS

**Stud:** Heat treated carbon steel  
**Spring:** Spring temper music wire  
**Cup:** Mild steel

### FINISHES

The basic PFSC finish, as called out by the tabulated part numbers, is cadmium plate per QQ-P-416, Type I, Class 2. Other standard finishes are available, as described at the bottom of this page.

### TYPE PVS35

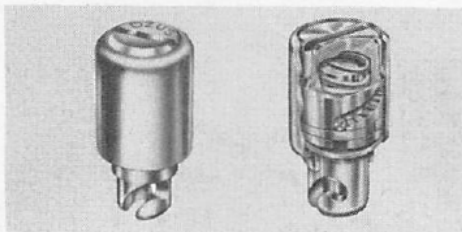

### DIMENSIONS

#### TYPE PVS 35 STUD ASSEMBLY

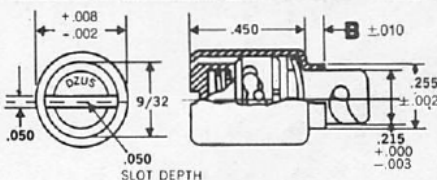

\* The table assumes the locked stud panel will contact Dzus receptacle strip having a wire depth (Dim. H) of .150".

Type PVS stud assemblies provide a nearly solid lock without allowing the sheet separation that occurs with PFSC assemblies while under tensile overload sufficient to overcome the expansion force of their springs. With PVS assemblies, the stud cam first quarter-turns onto the receptacle wire under spring tension supplied by a curved washer. Further locking rotation then starts to turn the cammed fastener head around a stud cross-pin. The head is moved downward as it turns, compressing a coil spring which is stronger than the curved washer, and finally compressing the curved washer flat. At the fully-locked position, the assembly has no remaining spring movement achievable by tensile overload. PVS assemblies are not MIL-F-25173A approved.

### CAUTION

Any external factor that prevents the stud from turning with initial locking torque could allow the fastener head to rotate first. This could convey an erroneous impression of locking while the stud cam has not locked onto the receptacle wire. All operators of this special purpose fastener should be trained to recognize proper stud cam locking.

### PARTS SELECTION \*

PANEL THICKNESS	STUD ASSEMBLY	CUP DIM. B
.050-.059	PVS35-37	.070
.060-.069	PVS35-38	.080
.070-.079	PVS35-39	.090
.080-.089	PVS35-40	.100
.090-.099	PVS35-41	.110
.100-.109	PVS35-42	.120
.110-.119	PVS35-43	.130
.120-.129	PVS35-44	.140

### SPECIFICATIONS

**Locking tension:** Variable, up to 200 lb.  
**Rated tensile and shear:** 200 lb. when used with Dzus receptacles.

### MATERIALS

Cup is mild steel. All other components are heat treated carbon steel.

### FINISHES

The basic PVS finish, as called out by the tabulated part numbers, is cadmium plate per QQ-P-416, Type I, Class 2. Other standard finishes are available, as described below.

## OPTIONAL BLACK FINISHES, PFSC AND PVS ASSEMBLIES

**Black Oxide Over Copper**—Copper plate .0003" to .0005", with dull black oxide conversion, and dull black wax coating. Available on all listed PFSC and PVS assemblies. Add suffix **RB** to basic part no.

**Black Chromate Over Cadmium**—Cadmium plate per QQ-P-416, Type II, Class 2, with black chromate finish. Available on all listed PFSC and PVS assemblies. Add suffix **CBB** to basic part no.

**Black Epoxy Paint Over Cadmium**—Cadmium plate per QQ-P-416, Type II, Class 2, plus black epoxy primer, .0006" min., and dull black epoxy enamel, .0003" min. Only visible surfaces in installed position are painted. Available on PFSC assemblies in -38, -41, and -44 lengths, and others on special order. Add suffix **SEB** to basic part no.

Horizontal Yout F



# STANDARD RECEPTACLE STRIPS

The Panel Line receptacle strip acts as a supporting frame for the panels or removable parts to be fastened, with continuous holes for stud engagement and rivet mounting on 3/8" centers. The strip is riveted to a support member and the stud panel rests against the strip face having the stud holes. The

strips are aluminum alloy with a continuous rigid stainless steel wire staked across the underside of the stud holes. The fastened panel rests on the strip and its captive 1/4-turn studs engage the rigid wire.

## RIGHT-ANGLE STRIP PR35

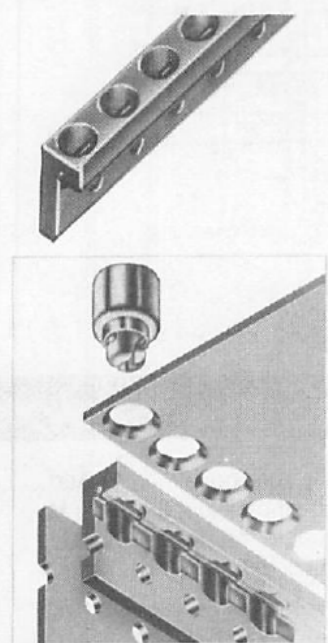

For mounting against a support member at right angle to the fastened panel or removable part. Standard strip length is 10 feet (320 Holes). We also have in approx. lengths 3 Ft., 5 Ft., 7 Ft., 9 Ft. (Part # PR35 S3, PR 35 S5, PR35 S7, PR 35 S9)  
**Materials:** Strip extrusion is aluminum alloy 6061-T6. Wire is stainless steel Type 316, condition B, spring temper.

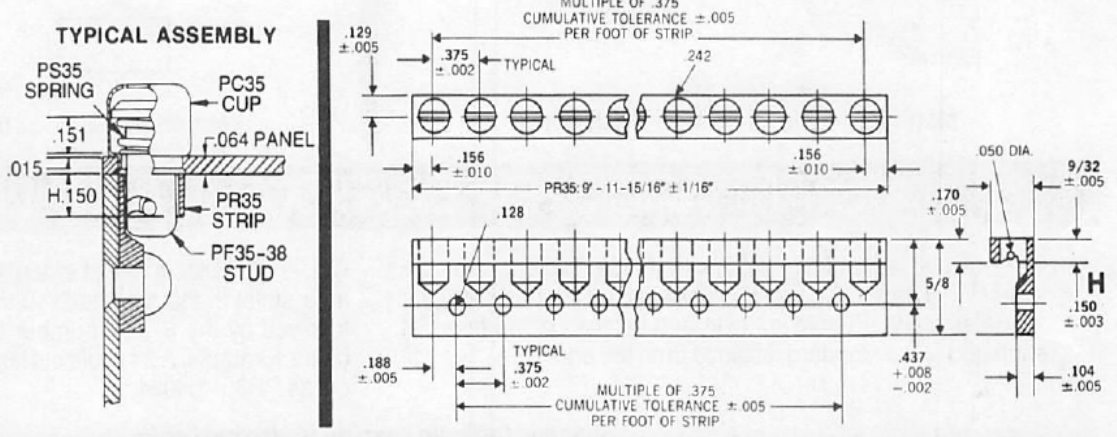

## FLAT STRIP PR35-1

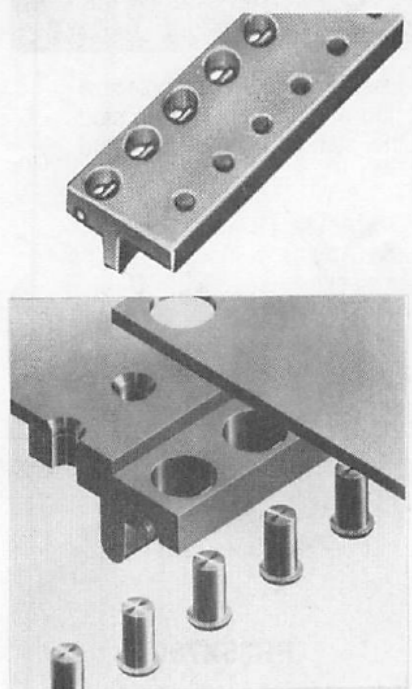

For mounting against a support member in plane with the fastened panel or removable part. Standard strip length is 10 feet (320 Holes). We also have in approx. lengths 3 Ft., 5 Ft., 7 Ft., 9 Ft. (Part # PR 35-1S3, PR 35-1S5, PR35-1S7, PR35-1S9)  
**Materials:** Strip extrusion is aluminum alloy 6061-T6. Wire is stainless steel Type 316, condition B, spring temper.

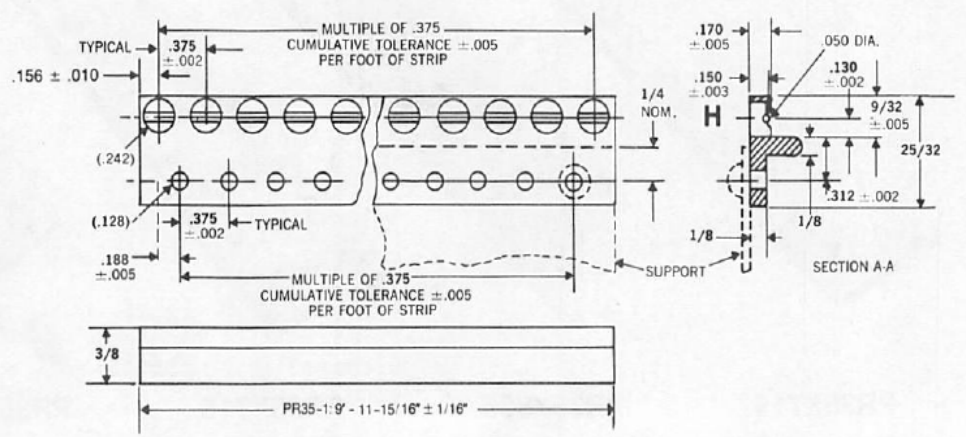

→ TONY KNOZOWAT  
 SINGLE HOLE RECEPTACLES  
 STRIPS CUT TO LENGTH  
 SPECIAL STRIPS

**RIGHT ANGLE SINGLE HOLE RECEPTACLE PRB35**

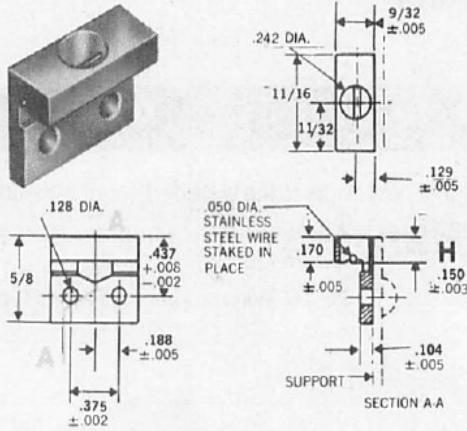

Weight (lb.) .0053

Materials: same as those for PR35 strip.

**FLAT SINGLE HOLE RECEPTACLE PRC35**

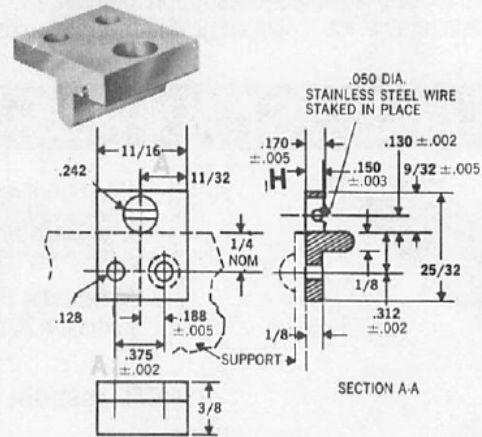

Weight (lb.) .0084

Materials: Same as those for PR35-1 strip.

**STANDARD STRIP CUSTOM CUT TO LENGTH**

Custom cut lengths of PR35 and PR35-1 strips may be specially ordered. The part callout system for cut lengths assumes standard hole spacing and location of the holes at each end at the standard distance from the end.

Cut length callouts with standard hole spacing and ends: Add as a suffix to the standard (10 foot) strip callout the letter H followed by the 3-digit number equal to the number of stud holes. Example: A 24-hole cut length of PR35-1 strip is called out as PR35-1H024.

*Special stud hole spacing is also available.  
 Consult our factory engineering office to discuss your requirements.*

**SPECIAL RECEPTACLE STRIPS**

Some of our previously-tooled special receptacle strips are shown below. Tooling and setup charges for such special strips are generally moderate.

All special strip configurations use the standard stud hole size and 'H' dimension (depth of stud engagement wire in stud hole), for compatibility with the standard panel line stud assemblies.

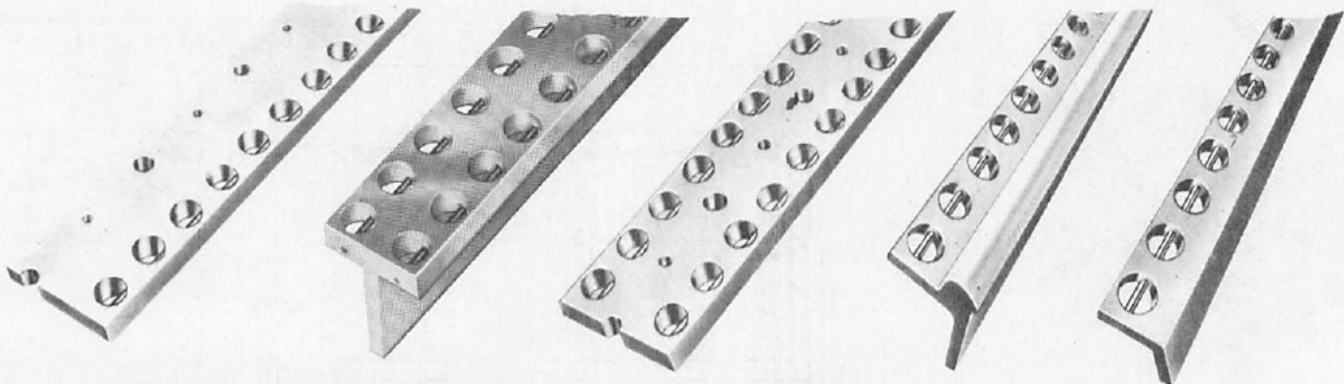

**PR35X714**

10' STANDARD LENGTH

**PR35X865**

10' STANDARD LENGTH

**PR35X715**

10' STANDARD LENGTH

**PR35X773**

9' STANDARD LENGTH

**PR35X780**

9' STANDARD LENGTH

# PANEL LINE INSTALLATION



## STUD PANEL PREPARATION

**1**

### DRILL AND COUNTERSINK HOLE

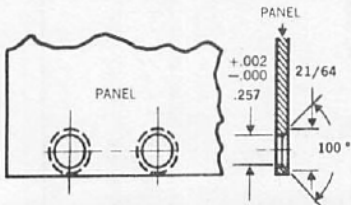

### TROUBLE SHOOTING USING HAND SQUEEZE TOOL

**PROBLEM:** Cup neck caves into cup shoulder instead of flaring into countersunk hole (Step 2).

**PROBABLE CAUSE:** (A). Vertical travel of panel pressure ring is restricted, or its spring pressure is reduced. (See Fig. 2 below). (B). Flaring rod is dull. (See Fig. 1 below for sharpening guide).

**PROBLEM:** Flared cup neck is split or uneven.

**PROBABLE CAUSE:** (A). Flaring rod is dull. (See Fig. 1 below for sharpening guide).

**PROBLEM:** Cup rotates in panel after flaring (Step 2). Note: Does not affect fastener operation.

**PROBABLE CAUSE:** (A). Incorrect panel hole diameter or countersink angle (Step 1). (B). Position of cup nest not properly adjusted for panel thickness. (See Fig. 2 below).

FLARING ROD  
FIGURE 1

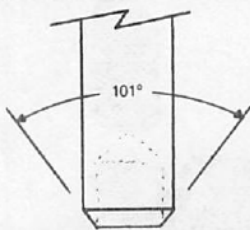
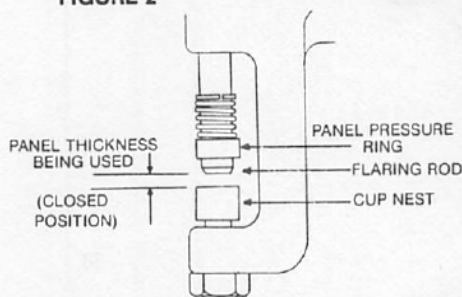

FIGURE 2



## FOR PRE-ASSEMBLED PFSC 35 AND PVS 35 WITH HAND SQUEEZE TOOL

Fastener PFSC 35 uses tool TP35AHT  
Fastener PVS 35 uses tool TP35VSHT

**1**

SEE STEP 1 FOR  
PANEL PREPARATION

**2**

INSERT FASTENER  
IN CUP NEST, AND  
PLACE PANEL  
OVER  
STUD.

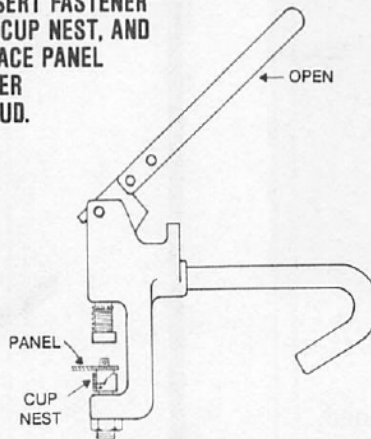

**3**

ENSURE PANEL IS FIRMLY AGAINST  
CUP SHOULDER, THEN SQUEEZE  
HANDLES TO FLARE CUP.

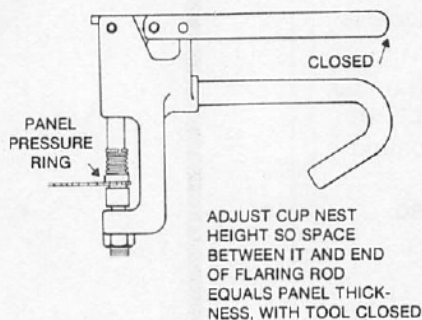

**3A**

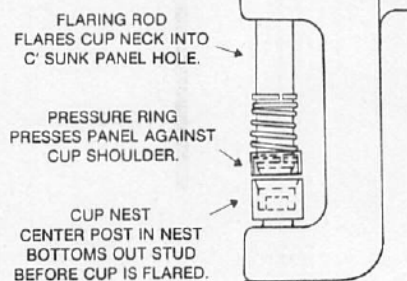

## FOR PRE-ASSEMBLED PFSC 35 WITH POWER-DRIVEN TOOLS

Tool and block under '2' are sold as tool set TTPT35A.

**1**

SEE STEP 1 FOR  
PANEL PREPARATION

**2**

INSERT FASTENER IN BLOCK,  
PLACE PANEL OVER STUD, ENSURE CUP  
SHOULDER IS FIRMLY AGAINST PANEL,  
AND FLARE WITH TOOL.

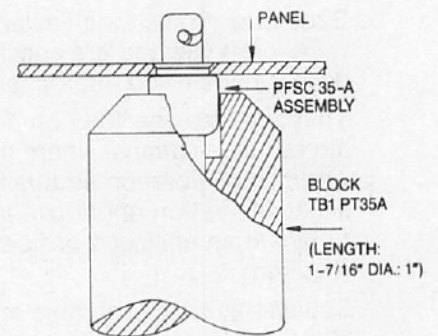
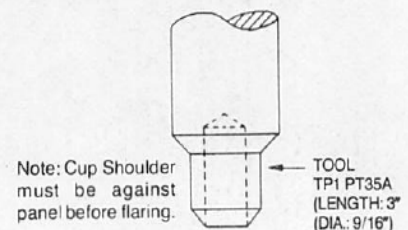

## FASTENER REMOVAL

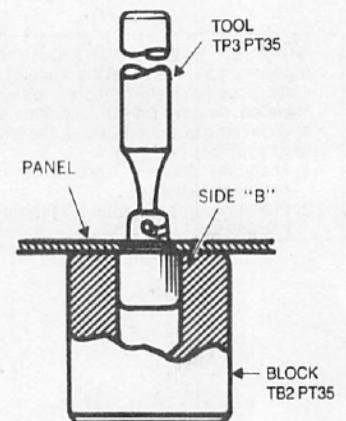

Get quote >>

Angic Global Solutions

1-888-872-0690

<https://www.AngicGlobal.com> Sales@AngicGlobal.com

**FAST**

**DZUS**

**FASTENING**

**SUPERSONIC LINE**

# 1/4-Turn Fasteners

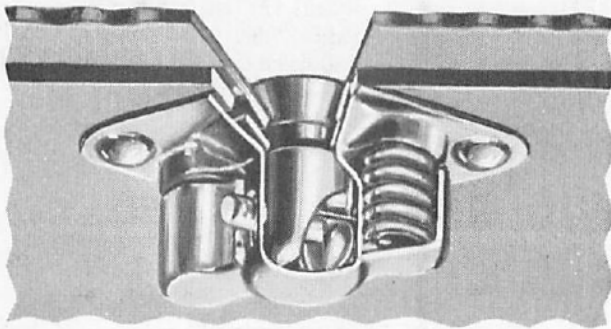

Dzus Supersonic Line Fasteners are designed for aircraft use and are specified on external access panels and internal equipment.

They are also specified on demanding non-aircraft applications, where their special qualities of vibration endurance and limited sheet separation under overload are needed, or where an enclosed or floating receptacle is required.

Supersonic Line Fasteners are approved under MIL-F-5591B for all sizes, sizes 2, 5, and 7, all stud types, types 1, 2, and 3, Class A floating and Class B rigid receptacles, and for the installation holes and stud retainers covered by styles 1 and 2.

**NOTE** — The selection and installation planning of fasteners can influence the security of the fastened parts. Dzus product information and support service is intended for use only by persons with mechanical engineering qualifications sufficient to manage the responsibilities of:

1. Analyzing fastener performance in relation to the service to be met, and
2. Planning appropriate fastening locations and installations.

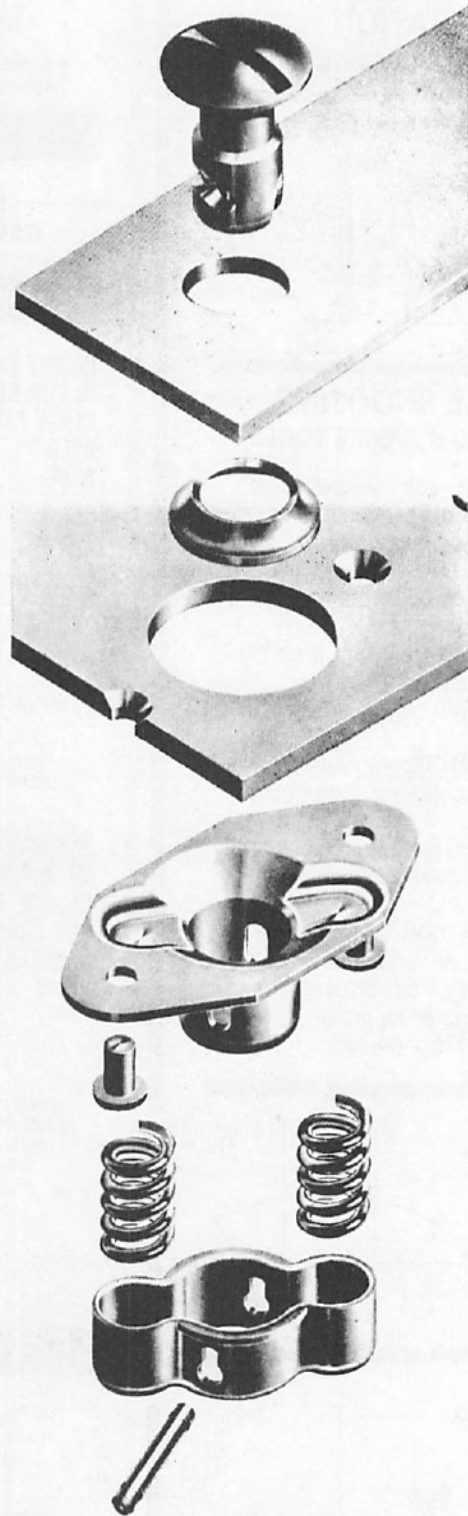

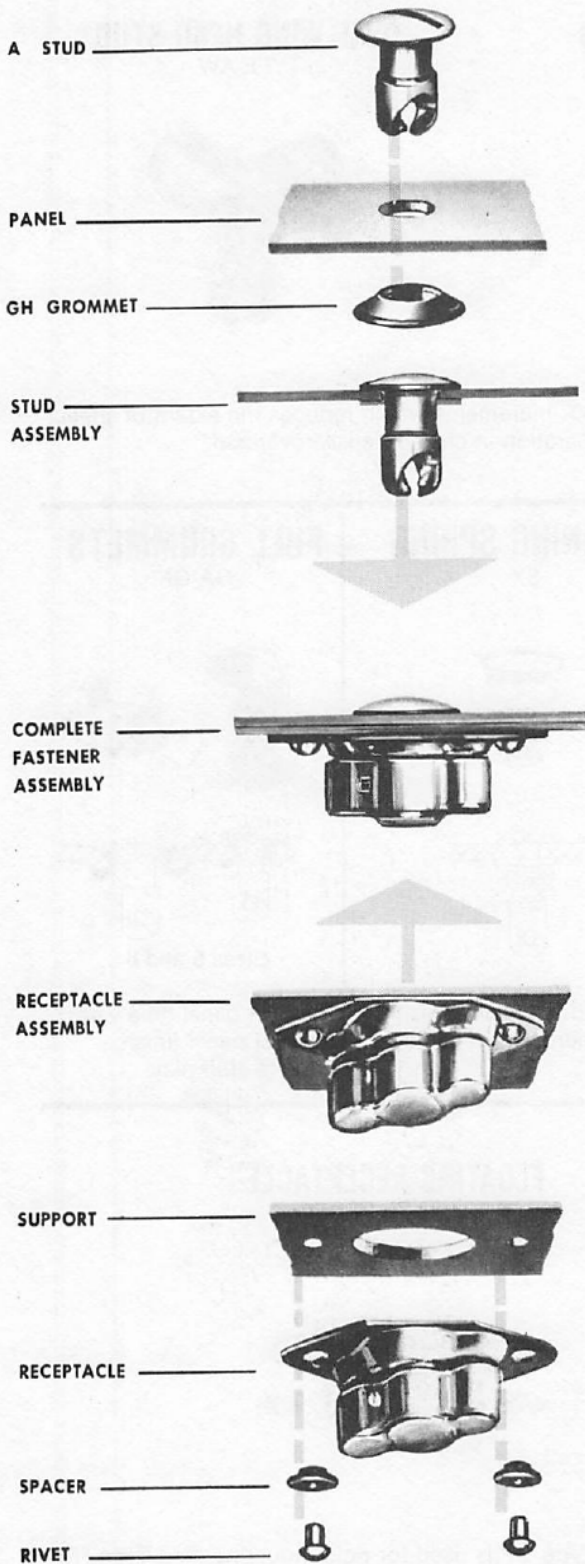

Supersonic Line Fasteners are offered in three sizes. Size 35 studs have 7/32" shank dia. and lock with 15 lb. clamping tension. Size 5 studs have 5/16" shank dia. and 35 lb. clamping tension. Size 6 studs have 3/8" shank dia. and 50 lb. clamping tension. See page 49 for additional performance data.

**SELECTION PROCEDURE**

1. Select the appropriate fastener size, with reference to the performance table on P. 48
2. Select a stud head style.
3. Select a stud retainer.
4. Determine the total thickness of material to be fastened. This is usually simply the combined thickness of the two materials on which the stud and receptacle are retained. See the stud page for detailed measurement instructions.
5. Determine the correct stud length for the total thickness of material to be fastened, using the table on the stud page.
6. Choose either a rigid or floating receptacle.

STUDS

**OVAL HEAD STUD**  
TYPE A



**FLUSH HEAD STUD**  
TYPE F



**OVAL WING HEAD STUD**  
TYPE AW



Supersonic Line studs are made of a higher-tensile alloy steel than Standard Line studs. Also, they are available in

.030" increments which reduces the extent of sheet separation in case of tensile overload.

RETAINERS

**HALF GROMMET**  
GH

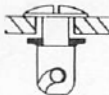

Solid. Retains when flattened.

**SNAP RING**  
SR

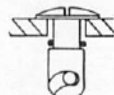

Split rings install fast, take little space.

**RETAINING SPRING**  
SX

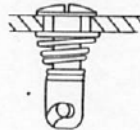

Holds stud in locking position for alignment with receptacle

**FULL GROMMETS**  
GA GF

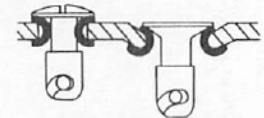
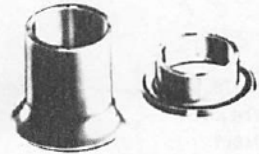

Sizes 5 and 6

Prevent panel hole wear, protect panel finish, reduce stud play.

RECEPTACLES

**RIGID RECEPTACLE**  
TYPE R

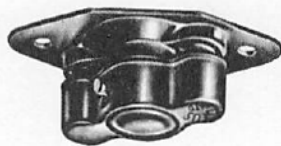

**FLOATING RECEPTACLE**  
TYPE RF

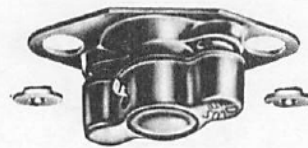

Supersonic receptacles are enclosed to protect the parts, prevent the loss of plating chips, and provide a smooth stud

entry. Type "R" is used for rigid mounting, and Type "RF" provides a floating feature to compensate for misalignment.

# SIZE 35 FLUSH, OVAL & WING HEAD STUDS

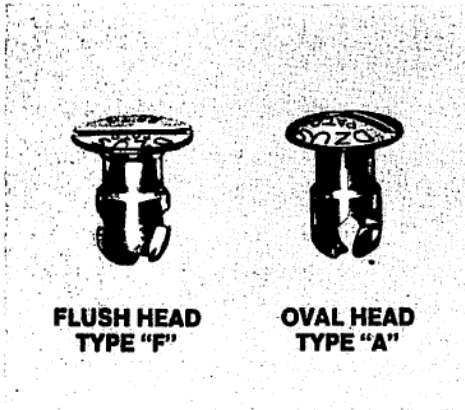

**FLUSH HEAD  
TYPE "F"**

**OVAL HEAD  
TYPE "A"**

**STANDARD MATERIALS, FINISHES**  
Hardened carbon steel studs, carbon steel wings. Cadmium plate per QQ-P-416 Type I, Class 2. Use basic part no.

**OPTIONAL YELLOW CHROMATE**  
Cadmium plate as above but with yellow chromate finish, Type II, Class 2. Add suffix **CBY** to basic part no.

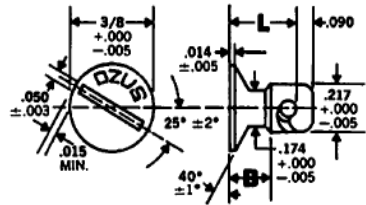

**FLUSH HEAD  
F35 STUD TYPE 1**

### STUD PART NUMBERS

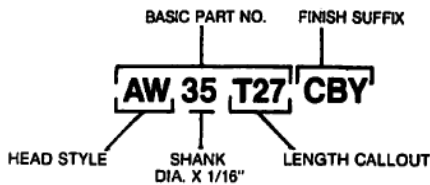

**OVAL HEAD  
A35 STUD TYPE 2**

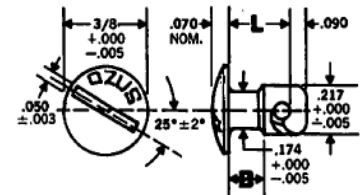

T TOTAL THICKNESS	STUD LENGTH CALLOUT	STUD SHANK DIMENSIONS		STUD WEIGHTS (LB. EA.)		
		L	B	FLUSH F35T	OVAL A35T	WING AW35T
0 - .030	T3	.260	.130	.00305	.00315	.00548
.031 - .060	T6	.290	.170	.0032	.0033	.00563
.061 - .090	T9	.320	.170	.00335	.00345	.00578
.091 - .120	T12	.350	.210	.0035	.0036	.00593
.121 - .150	T15	.380	.250	.00365	.00375	.00608
.151 - .180	T18	.410	.290	.0038	.0039	.00623
.181 - .210	T21	.440	.290	.00395	.00405	.00638
.211 - .240	T24	.470	.330	.0041	.0042	.00653
.241 - .270	T27	.500	.370	.00425	.00435	.00668
.271 - .300	T30	.530	.410	.0044	.0045	.00683
.301 - .330	T33	.560	.410	.00455	.00465	.00698
.331 - .360	T36	.590	.450	.0047	.0048	.00713
.361 - .390	T39	.620	.490	.00485	.00495	.00728

**WING HEAD  
AW35 STUD TYPE 3**

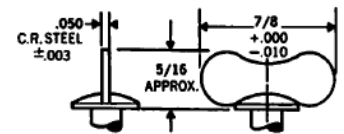

Otherwise same as A35 stud.

### FINDING TOTAL THICKNESS

Assuming the stud and receptacle to be in locked position, determine the distance between the level of stud head contact with the top of the panel in which it is retained, and the level of receptacle contact with the underside of the material on which it is mounted. Usually this distance is simply the combined thickness of the stud panel and receptacle support material, but gaskets or standoffs between panel and support can also add space. Material between the stud head and top of the panel, such as a full grommet, must also be counted, as must paint thickness applied to every intervening surface. Do not count stud retainer thickness on the panel underside, which enters the support hole.

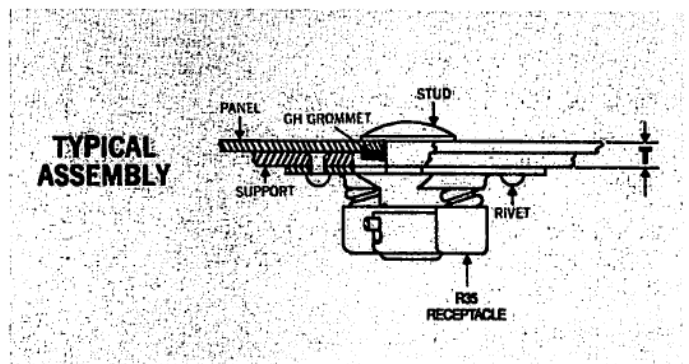

Get quote >>

**STUD RETAINERS**

**TYPE GH HALF GROMMET**

For use with F, A and AW studs

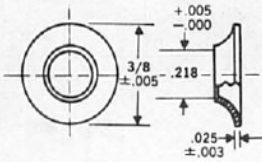

Part No.: GH35  
 Material: Aluminum  
 Weight in lbs.: .000219

**SNAP RING**

For use with F, A and AW studs

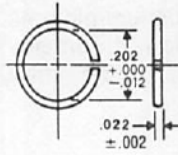

Part No.: SR35SS  
 Material: Stainless steel, 300 series, spring temper.  
 Weight in lbs.: .00009

**RETAINING SPRING**

For use with A and AW studs

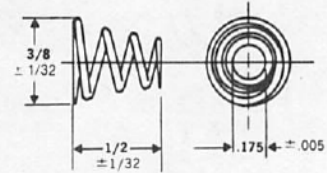

Part No.: SX551SS  
 Material: Stainless steel, 300 series, spring temper.  
 Weight in lbs.: .00038

**RECEPTACLES**



**RIGID RECEPTACLE R35 (CLASS B)**  
 For use with any size 35 Supersonic Line stud.

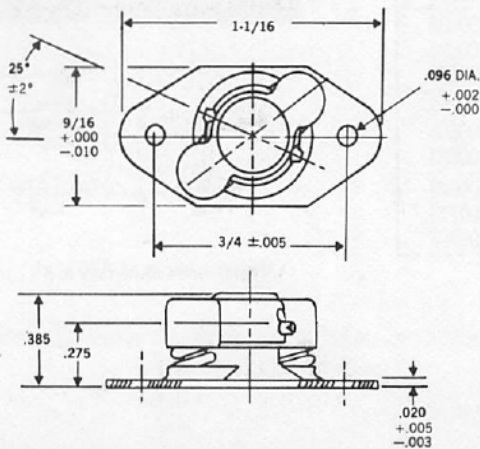

**STANDARD MATERIALS, FINISHES**  
 Receptacle base and spring cap: steel, cadmium plated. Spring and pin: Music wire, cadmium plated Cadmium plate per QQ-P-416, Type I, Class 2.

Optional yellow chromate: Cadmium plate with yellow chromate finish per QQ-P-416, Type II, Class 2. Add suffix **CBY** to basic part no.

Weight (lb.) .0071

**FLOATING RECEPTACLE**

**RF35 (CLASS A)**

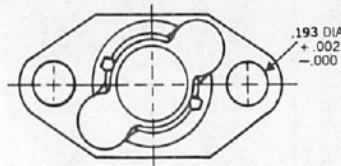

Part No.: RF35  
 Materials: Same as R35 Receptacle  
 Weight (lbs.): .0072 (this figure includes two RF35 Spacers)  
 Float: .050 All Directions  
 (Otherwise same as R35 receptacle.)

**SPACER**

2 included with RF35 Receptacle

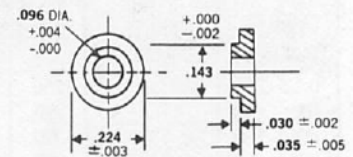

Part No.: RF35-5  
 Material: Same as receptacle base.

**FLOATING RECEPTACLE**

**RF35 x 734**

For thin paneling, .032 or less.  
 (Otherwise same as RF35 receptacle)

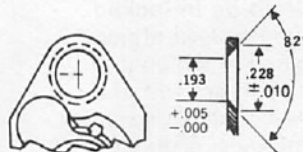

Materials: Same as R35 Receptacle  
 Weight (lbs.): .0072 (this figure includes two RF35 x 734-1 Spacers.)

**SPACER**

2 included with RF35 x 734 Receptacle

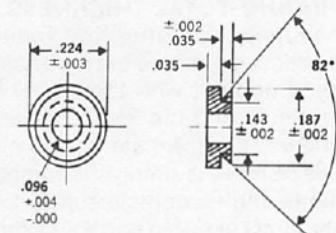

Part No.: RF35 x 734-1  
 Material: Same as receptacle base.

# SIZE 5 FLUSH, OVAL & WING HEAD STUDS

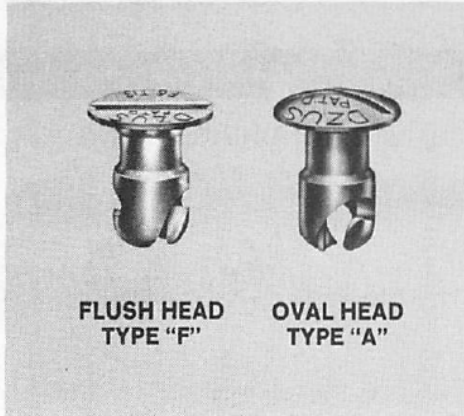

FLUSH HEAD  
TYPE "F"

OVAL HEAD  
TYPE "A"

**STANDARD MATERIALS, FINISHES**  
Hardened carbon steel studs, carbon steel wings. Cadmium plate per QQ-P-416 Type I, Class 2. Use basic part no.

**OPTIONAL YELLOW CHROMATE**  
Cadmium plate as above but with yellow chromate finish, Type II, Class 2. Add suffix **CBY** to basic part no.

## FLUSH HEAD F5 STUD TYPE 1

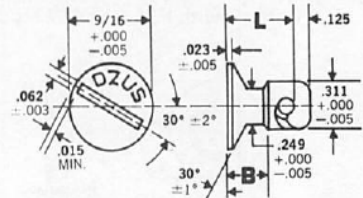

## OVAL HEAD A5 STUD TYPE 2

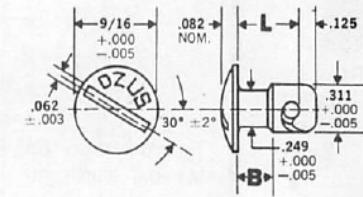

## WING HEAD AW5 STUD TYPE 3

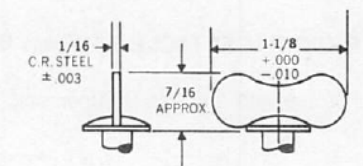

Otherwise same as A 5 stud.

### STUD PART NUMBERS

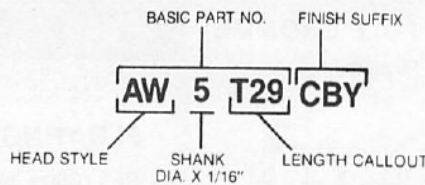

T TOTAL THICKNESS	STUD LENGTH CALLOUT	STUD SHANK DIMENSIONS		STUD WEIGHTS (LB. EA.)		
		L	B	FLUSH F5T	OVAL A5T	WING AW5T
.021 - .050	T5	.350	.170	.00775	.00745	.01299
.051 - .080	T8	.380	.210	.00828	.00798	.01352
.081 - .110	T11	.410	.250	.0088	.0085	.01404
.111 - .140	T14	.440	.250	.00933	.00903	.01457
.141 - .170	T17	.470	.290	.00985	.00955	.01509
.171 - .200	T20	.500	.330	.01038	.01008	.01548
.201 - .230	T23	.530	.370	.0109	.0106	.01614
.231 - .260	T26	.560	.370	.01143	.01113	.01667
.261 - .290	T29	.590	.410	.01195	.01165	.01719
.291 - .320	T32	.620	.450	.01248	.01218	.01772
.321 - .350	T35	.650	.490	.013	.01270	.01824
.351 - .380	T38	.680	.490	.01353	.01323	.01877
.381 - .410	T41	.710	.530	.01405	.01375	.01929
.411 - .440	T44	.740	.570	.01458	.01428	.01982

### FINDING TOTAL THICKNESS

Assuming the stud and receptacle to be in locked position, determine the distance between the level of stud head contact with the top of the panel in which it is retained, and the level of receptacle contact with the underside of the material on which it is mounted. Usually this distance is simply the combined thickness of the stud panel and receptacle support material, but gaskets or standoffs between panel and support can also add space. Material between the stud head and top of the panel, such as a full grommet, must also be counted, as must paint thickness applied to every intervening surface. Do not count stud retainer thickness on the panel underside, which enters the support hole.

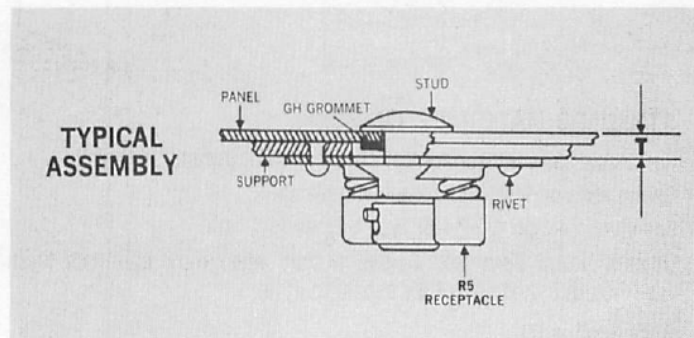

Get quote »

Angic Global Solutions

1-888-872-0690

<https://www.AngicGlobal.com> [Sales@AngicGlobal.com](mailto:Sales@AngicGlobal.com)

**STUD RETAINERS**

**TYPE GH HALF GROMMET**

For use with F, A and AW studs

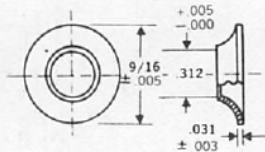

Part No.: GH5  
 Material: aluminum  
 Weight in lbs.: .00069

**SNAP RING**

For use with F, A and AW studs

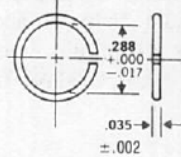

Part No.: SR5SS  
 Material: Stainless steel, 300 series,  
 spring temper.  
 Weight in lbs.: .00027

**RETAINING SPRING**

For use with A and AW studs

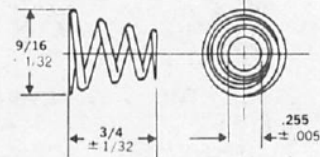

Part No.: SX510SS  
 Material: Stainless steel, 300 series,  
 spring temper.  
 Weight in lbs.: .00144

**TYPE GA FULL GROMMET**

For use with A5 and AW5 studs.

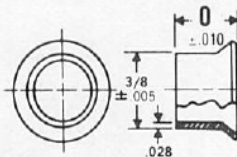

Typical Part No.: GA5-312 ("0" = .312)\*  
 Material: aluminum.

**TYPE GF FULL GROMMET**

For use with F5 studs

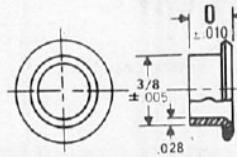

Typical Part No.: GF5-175 (0 = .175)\*  
 Material: aluminum.

\*Available in lengths to fit most common panel gages. Selection tables on Page 23.



**FLOATING RECEPTACLE**  
**RF5 (Class A)**

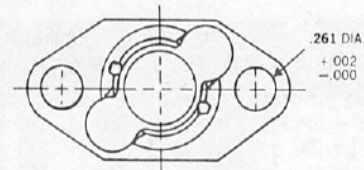

Part No.: RF5  
 Materials: Same as R5 Receptacle  
 Weight (lbs.): .0183 (this figure includes  
 two RF-5 Spacers)  
 Float: .074 All Directions  
 (Otherwise same as R5 receptacle)

**RECEPTACLES**

**RIGID RECEPTACLE R5 (Class B)**

For use with any size 5 Supersonic Line stud.

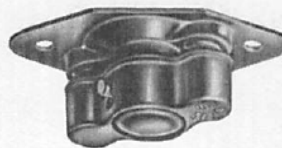
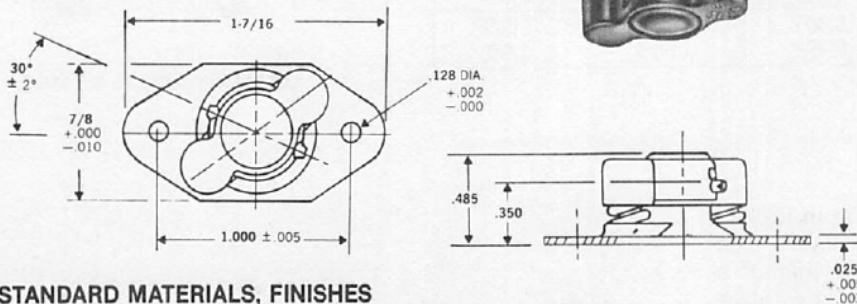

**STANDARD MATERIALS, FINISHES**

Receptacle base and spring cap: steel, cadmium plated.  
 Spring and pin: Music wire, cadmium plated.  
 Cadmium plate per QQ-P-416, Type I, Class 2.  
 Optional yellow chromate: Cadmium plate with yellow chromate finish per QQ-P-416,  
 Type II Class 2. Add suffix **CBY** to basic part no.  
 Weight (lb.): .0171

For Supersonic Line Installation See Page 47

**SPACER**

2 Included with RF5 Receptacle

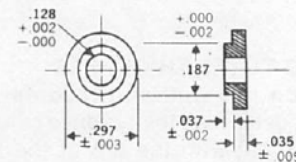

Part No.: RF5-5  
 Material: Same as receptacle base.

# SIZE 6 FLUSH, OVAL & WING HEAD STUDS

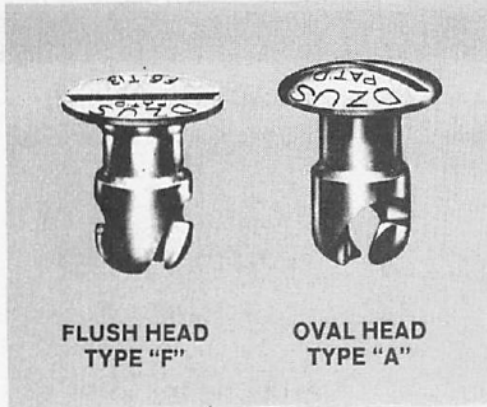

FLUSH HEAD  
TYPE "F"

OVAL HEAD  
TYPE "A"

**STANDARD MATERIALS, FINISHES**  
 Hardened carbon steel studs, carbon steel wings. Cadmium plate per QQ-P-416 Type I, Class 2. Use basic part no.

**OPTIONAL YELLOW CHROMATE**  
 Cadmium plate as above but with yellow chromate finish, Type II, Class 2. Add suffix **CBY** to basic part no.

**FLUSH HEAD  
 F6 STUD TYPE 1**

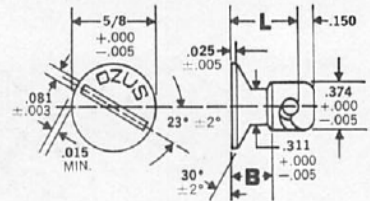

**OVAL HEAD  
 A6 STUD TYPE 2**

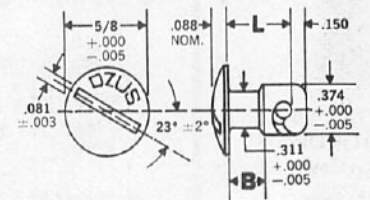

**WING HEAD  
 AW6 STUD TYPE 3**

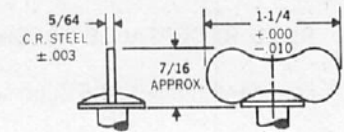

**STUD PART NUMBERS**

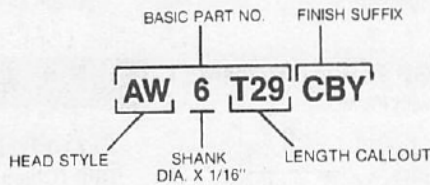

T TOTAL THICKNESS	STUD LENGTH CALLOUT	STUD SHANK DIMENSIONS		STUD WEIGHTS (LB. EA.)		
		L	B	FLUSH F6T	OVAL A6T	WING AWGT
.021 - .050	T5	.410	.180	.012	.01260	.02097
.051 - .080	T8	.440	.230	.01272	.01332	.02169
.081 - .110	T11	.470	.280	.01344	.01404	.02241
.111 - .140	T14	.500	.280	.01416	.01476	.02313
.141 - .170	T17	.530	.330	.01488	.01548	.02385
.171 - .200	T20	.560	.330	.0156	.0162	.02457
.201 - .230	T23	.590	.380	.01632	.01692	.02529
.231 - .260	T26	.620	.430	.01704	.01764	.02601
.261 - .290	T29	.650	.430	.01776	.01836	.02673
.291 - .320	T32	.680	.480	.01848	.01908	.02745
.321 - .350	T35	.710	.480	.0192	.0198	.02817
.351 - .380	T38	.740	.530	.01992	.02052	.02889
.381 - .410	T41	.770	.580	.02064	.02124	.02961
.411 - .440	T44	.800	.580	.02136	.02196	.03033
.441 - .470	T47	.830	.630	.02208	.02268	.03105
.471 - .500	T50	.860	.630	.0228	.0234	.03177

**FINDING TOTAL THICKNESS**

Assuming the stud and receptacle to be in locked position, determine the distance between the level of stud head contact with the top of the panel in which it is retained, and the level of receptacle contact with the underside of the material on which it is mounted. Usually this distance is simply the combined thickness of the stud panel and receptacle support material, but gaskets or standoffs between panel and support can also add space. Material between the stud head and top of the panel, such as a full grommet, must also be counted, as must paint thickness applied to every intervening surface. Do not count stud retainer thickness on the panel underside, which enters the support hole.

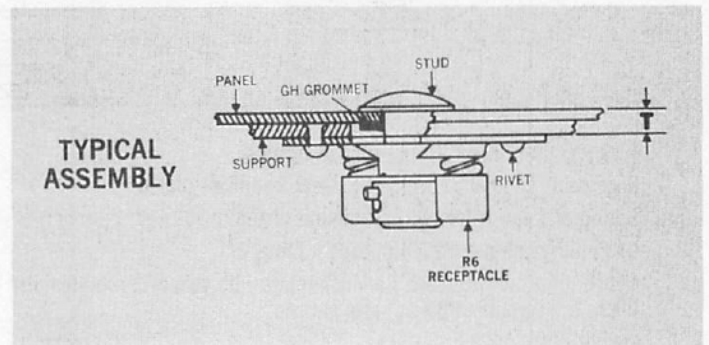

Get quote >>

**STUD RETAINERS**

**TYPE GH HALF GROMMET**

For use with F, A and AW studs

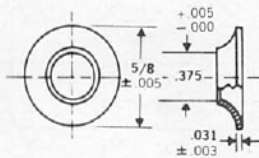

Part No.: GH6  
 Material: aluminum  
 Weight in lbs.: .00081

**SNAP RING**

For use with F, A and AW studs

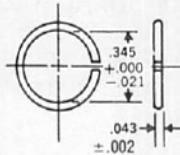

Part No.: SR6SS  
 Material: Stainless steel, 300 series,  
 spring temper.  
 Weight in lbs.: .00050

**RETAINING SPRING**

For use with A and AW studs

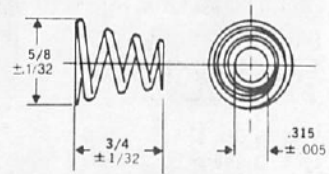

Part No.: SX518SS  
 Material: Stainless steel, 300 series,  
 spring temper.  
 Weight in lbs.: .00194



**TYPE GA FULL GROMMET**

For use with A6 and AW6 studs

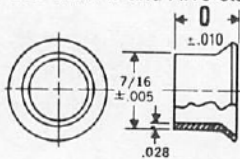

Typical Part No.: GA6-350 (O = .350)\*  
 Material: aluminum

**TYPE GF FULL GROMMET**

For use with F6 studs

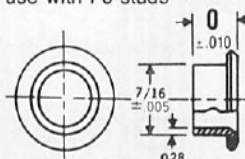

Typical Part No.: GF6-250 (O = .250)\*  
 Material: aluminum

\*Available in lengths to fit most common panel gages.  
 Selection tables on Page 23.

**FLOATING RECEPTACLE RF6 (Class A)**

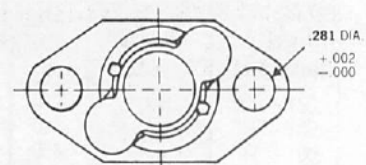

Part No.: RF6  
 Materials: Same as R6 Receptacle  
 Weight (lbs.): .0346 (this figure includes  
 two RF6-5 Spacers)  
 Float: .094 All Directions  
 (Otherwise same as R6 receptacle)

**RECEPTACLES**

**RIGID RECEPTACLE R6 (Class B)**

For use with any size 6 Supersonic Line stud.

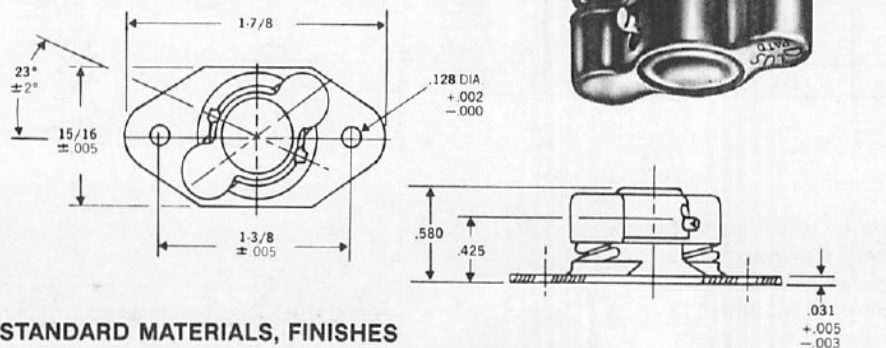

**STANDARD MATERIALS, FINISHES**

Receptacle base and spring cap: steel, cadmium plated.  
 Spring and pin: Music wire, cadmium plated.  
 Cadmium plate per QQ-P-416, Type I, Class 2.  
 Optional yellow chromate: Cadmium plate with yellow chromate finish per QQ-P-416, Type II,  
 Class 2. Add suffix **CBY** to basic part no.  
 Weight (lbs.): .0333

**SPACER**

2 Included with RF6 Receptacle

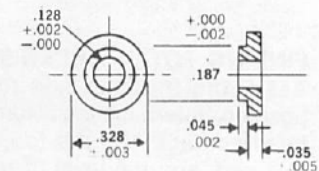

Part No.: RF6-5  
 Material: Same as receptacle base.

# SUPERSONIC LINE INSTALLATION



## FLUSH HEAD WITH GH HALF GROMMET

**1**

DRILL AND DIMPLE  
HOLE IN PANEL

Type of Stud	Dia. of Hole Before Dimpling	B +.010 - .000 (Dia. of Hole After Dimpling)	D +.010 - .000	H ±2°
F35	.189	.218	.406	100°
F5	3/16	.312	.640	120°
F6	3/8	.375	.710	120°

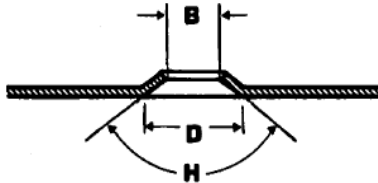

**2**

INSERT STUD AND SLIP  
GROMMET OVER STUD



**3**

FLATTEN GROMMET

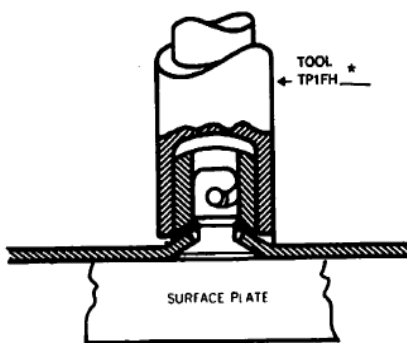

## OVAL HEAD WITH GH HALF GROMMET

**1**

DRILL HOLE IN PANEL

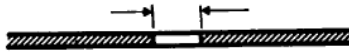

Stud Type	Hole Diameter
A35 -AW35	3/32
A5 -AW5	3/16
A6 -AW6	3/8

**2**

INSERT STUD AND SLIP  
GROMMET OVER STUD



**3**

FLATTEN GROMMET

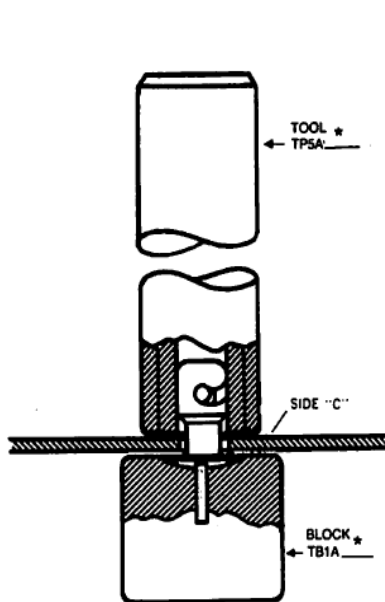

\*ADD SIZE NUMBER TO  
COMPLETE TOOL CALLOUT.

## OVAL HEAD WITH RETAINING RING AND RETAINING SPRING

**1**

DRILL HOLE IN PANEL

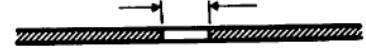

Stud Type	Hole Diameter
A35 -AW35	3/32
A5 -AW5	3/16
A6 -AW6	3/8

**2**

INSERT STUD

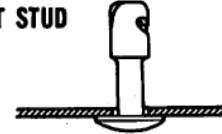

**3**

SLIP PLUG INTO STUD-PLACE  
RING OR SPRING OVER PLUG

For ease of installation align end of  
spring or split in ring with uncut  
portion of stud (see dotted line).

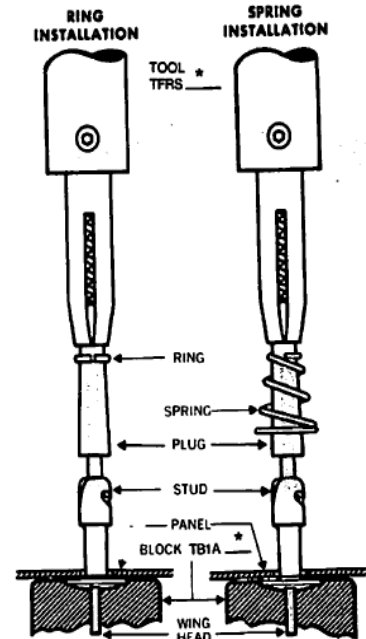

Get quote »

Angic Global Solutions

1-888-872-0690

<https://www.AngicGlobal.com> [Sales@AngicGlobal.com](mailto:Sales@AngicGlobal.com)

### TYPE R—RIGID RECEPTACLE

**1**

DRILL HOLES & COUNTERSINK  
RIVET HOLES

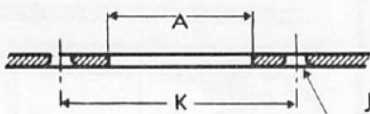

Type of Stud	A ±.010	K ±.005	J
A35 -F35	.468	.750	.096
A5 -F5	.703	1.000	.128
A6 -F6	.812	1.375	.128

Type of Stud	Drill Size	Counter-sink	Rivet
A35 -F35	#41 (.096)	3/16D × 110°	3/32
A5 - F5	#30	1/4D	1/8
A6 - F6	(.128)	× 110°	

**2**

RIVET RECEPTACLE

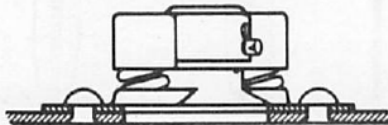

### TYPE RF—FLOATING RECEPTACLE

**1**

DRILL HOLES & COUNTERSINK  
RIVET HOLES

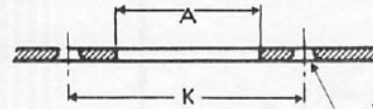

Type of Stud	A ±.010	K ±.005	J
A35 -F35	.468	.750	.096
A5 -F5	.703	1.000	.128
A6 -F6	.812	1.375	.128

Type of Stud	Drill Size	Counter-sink	Rivet
A35 -F35	#41 (.096)	3/16D × 110°	3/32
A5 - F5	#30	1/4D	1/8
A6 - F6	(.128)	× 110°	

**2**

PLACE SPACERS IN RECEPTACLE HOLES

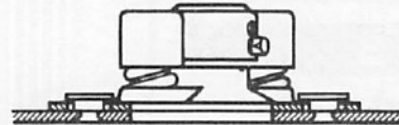

**3**

RIVET RECEPTACLE

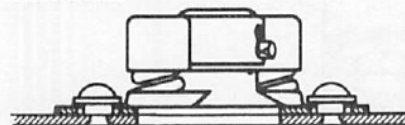

### MECHANICAL PROPERTIES MIL-F-5591B (STYLE 1—TYPES 1-2-3 CLASS A & B)

Size AN	Dzus	Locking Torque		Initial Tension	Tension & Shear		Locking Stop Strength	Endurance (Cycles)
		Minimum	Maximum		Rated	Plus 50%		
7	6	7.5 IN. LB.	18 IN. LB.	50 LB.	700 LB.	1050 LB.	80 IN. LB.	40,000
5	5	5.0 IN. LB.	12 IN. LB.	35 LB.	500 LB.	750 LB.	60 IN. LB.	25,000
2	35	3.5 IN. LB.	8 IN. LB.	15 LB.	200 LB.	300 LB.	30 IN. LB.	5,000

**TORQUE—ABSOLUTE MAXIMUM**—Not over 133% of rated maximum with .010 shim added

**FAST**

**DZUS**

**FASTENING**

**DART LINE**

# Plastic 1/4-Turn Fasteners

Reliable Access Fastening at  
Low Installed Cost

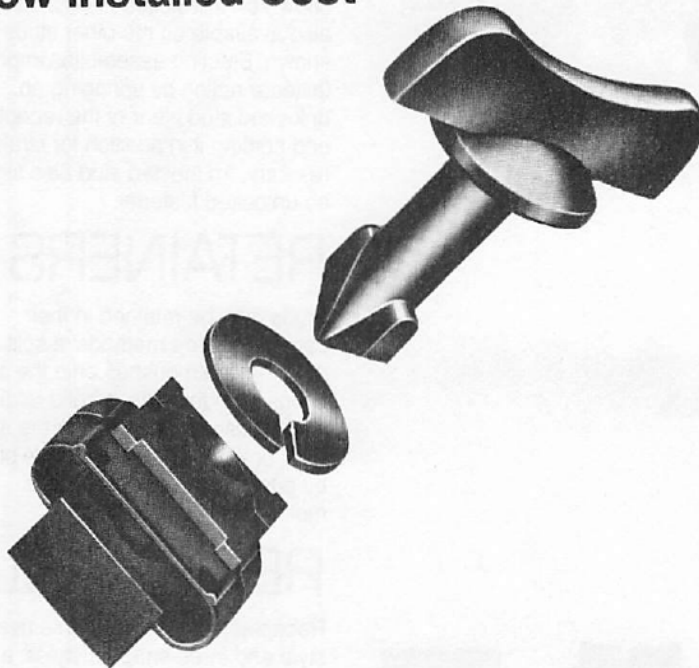

Dart Line fasteners provide an operating feel and service life close to that of aircraft-grade steel 1/4-turns. They offer outstanding value on products suitable for plastic parts in their strength range.

1/4-turn rotation provides locking or release with a crisp snap action. The fasteners lock with a vibration-resistant clamping tension, cannot be over-turned, and may be operated thousands of times.

Installation is fast and secure. Studs may be held with push-on retainers or pushed through molded one-way holes. Receptacles may be riveted or snapped into rectangular holes from above or behind.

The evident quality experienced in Dart Line fastener operation will reflect well on the products which use them.

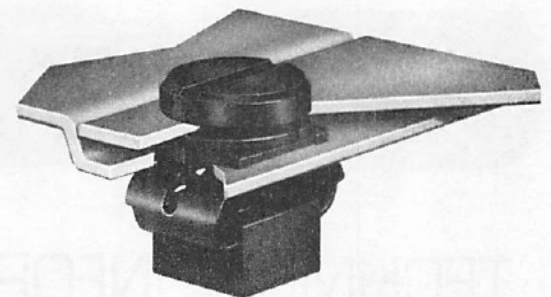
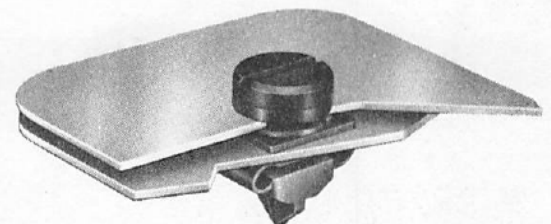
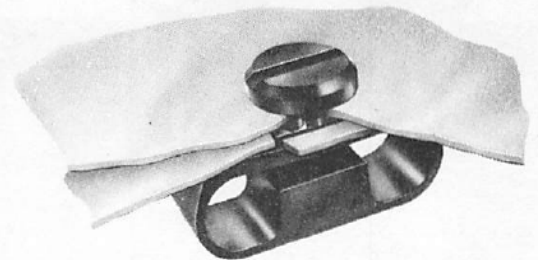
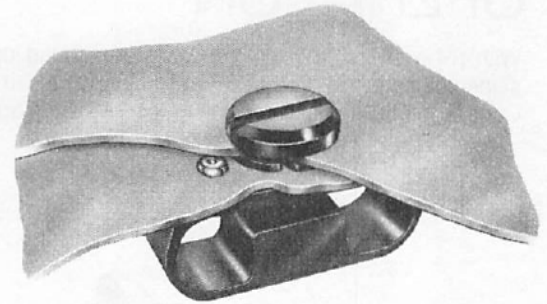

**NOTE** —The selection and installation planning of fasteners can influence the security of the fastened parts. Dzus product information and support service is intended for use only by persons with mechanical engineering qualifications sufficient to manage the responsibilities of:

1. Analyzing fastener performance in relation to the service to be met, and
2. Planning appropriate fastening locations and installations.



**OPERATION**

With 1/4-turn stud rotation, the dart-shaped stud lugs engage sloped cams in the receptacle and lock into a dead-end detent. Cam action pulls the bottom of the receptacle up against spring

tension. Arrival at locked position is obvious, due to an over-rotation stop and a detent snap action that can be felt.

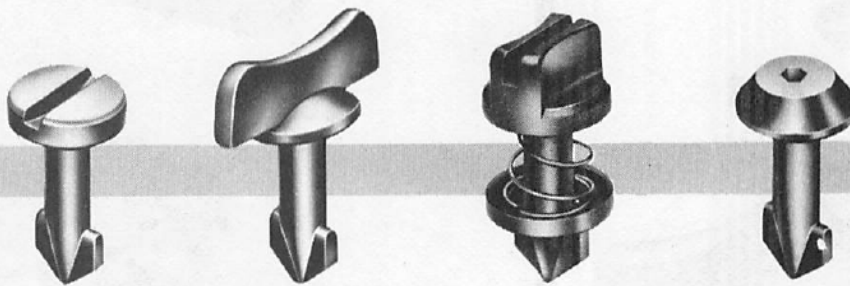

**STUDS**

Studs are available in the four standard head styles shown. Special heads are possible up to 1.25" diameter.

The optional ejecting assembly shown on the slotted knob stud is also available on the other studs shown. Ejecting assemblies improve fastener action by springing an unlocked stud clear of the receptacle and holding it in position for straight re-entry. An ejected stud also signals an unlocked fastener.



**RETAINERS**

Studs may be retained in their panels by three methods: a split retainer which pushes onto the stud shank from the side, a solid retainer which pushes straight over the stud lugs, or if the panel is a ductile plastic, by pushing the lugs through a molded interference-fit hole.

**RECEPTACLES**

Receptacles are offered in a riveted style and three snap-in styles: a high-performance rear load, a mini rear load, and a mini top load. All receptacles meet the performance specs tabulated below, but the two larger versions offer smoother operation and more even locking torque across their material grip range.

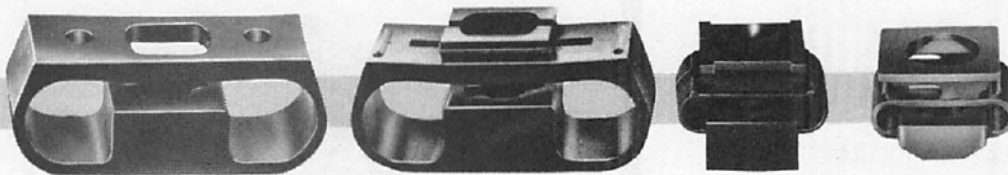

**TECHNICAL INFORMATION**

Material, all components .....	Acetal Copolymer Resin—Material Burning Rating Code UL 94 HB. ASTM E-162 Flame Spread Index: 130.
Ultimate tensile strength .....	180 lbs.
Locked service tension (min.) .....	13 lbs.
Locking stop strength .....	15 lbs. in.
Wear resistance .....	5000 + cycles
Temperature resistance .....	High 194°F (248°F intermittent) Low—40°F

# STUDS

The four head styles shown are standard. Head style is called out by the first three digits of the part number. The middle three digits call out stud length. The component selection tables on the following pages give the stud length callout for the thickness

being fastened. The last three digits call out color, -010 being for standard black. Stud material is acetal resin. Custom colors and head styles are possible on special order.

<p><b>STRAIGHT SLOT</b></p> <p>004-045-010 to 004-100-010</p>	<p><b>SLOTTED KNOB</b></p> <p>444-045-010 to 444-100-010</p>	<p><b>WING</b></p> <p>124-045-010 to 124-100-010</p>	<p><b>TOOL-ONLY</b></p> <p>HEX RECESS ACCEPTS 5/32 OR 4MM KEY.</p> <p>166-045-010 to 166-100-010</p>
---	--	--	--

**STUD SHANK DIMENSIONS**

The stud's middle callout numbers indicate its 'L' Dim. in hundredths of an inch. The component selection tables on the following pages will show the correct 'L' dimension for the material thickness being fastened.

**EJECTING STUD ASSEMBLY**

SE

Studs may be ordered as an ejecting assembly by adding to the end of the stud callout the suffix SE. When using the component selection tables, add the .090 cup height above the stud panel to your panel thickness. Installed stud will be ejected against panel underside when open.

Material: Cup—Black Acetal Resin  
Spring—Stainless Steel

**PANEL STUD HOLE**

**SELF-RETAINING HOLE**

Recommended trial hole for interference fit in ductile plastic panels.

**SPLIT STUD RETAINER**

004-000-010

Pushes onto stud shank from the side.

Material: Black Acetal Resin

**SOLID STUD RETAINER**

GP5B

Pushes straight over stud end lugs.

Material: Black Thermoplastic

**RIVET-IN**

**004-001-010**

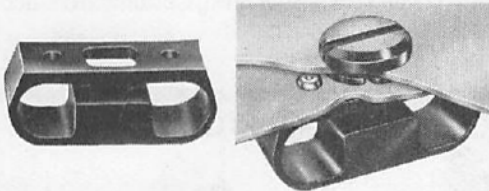

**INSTALLATION**  
 Attach receptacle using flat head aluminum blind rivets 1/8" Dia., steel rivets are not recommended.

**SUPPORT PREPARATION**

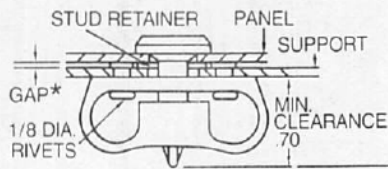
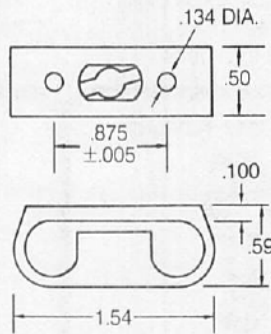
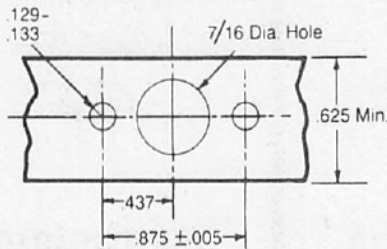

\*GAP: The greater of rivet head thickness or stud retainer thickness (if used). Note that these parts may also be nested into recessed holes.

RIVET-IN RECEPTACLE 004-001-010	
THICKNESS OF SUPPORT PLUS GAP* PLUS PANEL	YOUR STUD LENGTH DIM. 'L'
.100 to .149	-045-
.150 to .199	-050-
.200 to .249	-055-
.250 to .299	-060-
.300 to .349	-065-
.350 to .399	-070-
.400 to .449	-075-
.450 to .499	-080-
.500 to .549	-085-
.550 to .599	-090-
.600 to .649	-095-
.650 to .699	-100-

**SNAP-IN, BACK INSTALLED, HIGH PERFORMANCE 004-002-010 THROUGH 004-006-010**

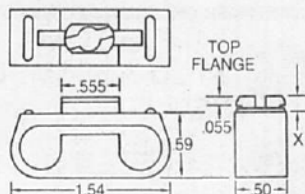
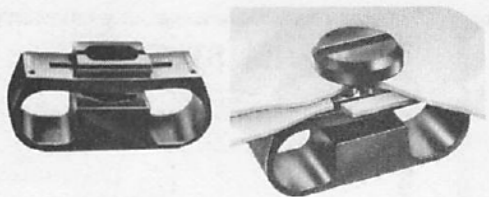

CALLOUT	"X"
-002-	.110
-003-	.143
-004-	.167
-005-	.198
-006-	.228

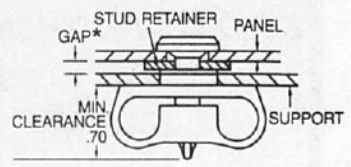

- INSTALLATION**
1. Angle long notched side of top flange into hole from underside.
  2. Push other long side completely through with flat blade screwdriver.

**SUPPORT PREPARATION**

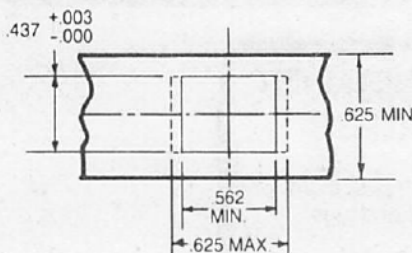

\*GAP: Combined thickness of receptacle top flange and stud retainer (if used). Note that these parts may also be nested into recessed holes.

SNAP-IN RECEPTACLE, HIGH PERFORMANCE BACK LOAD 004-***-010				
FIND YOUR SUPPORT THICKNESS				
.032 to .050	.064 to .080	.090 to .104	.119 to .135	.149 to .165
FOLLOW ITS COLUMN DOWN TO YOUR RECEPTACLE				
*** -002-	*** -003-	*** -004-	*** -005-	*** -006-
THEN TO YOUR PANEL PLUS GAP* THICKNESS				
.035 to .084	—	—	—	—
.085 to .134	.035 to .084	.035 to .084	—	—
.135 to .184	.085 to .134	.085 to .134	.035 to .084	.035 to .084
.185 to .234	.135 to .184	.135 to .184	.085 to .134	.085 to .134
.235 to .284	.185 to .234	.185 to .234	.135 to .184	.135 to .184
.285 to .334	.235 to .284	.235 to .284	.185 to .234	.185 to .234
.335 to .384	.285 to .334	.285 to .334	.235 to .284	.235 to .284
.385 to .434	.335 to .384	.335 to .384	.285 to .334	.285 to .334
.435 to .484	.385 to .434	.385 to .434	.335 to .384	.335 to .384
.485 to .534	.435 to .484	.435 to .484	.385 to .434	.385 to .434
.535 to .584	.485 to .534	.485 to .534	.435 to .484	.435 to .484
.585 to .634	.535 to .584	.535 to .584	.485 to .534	.485 to .534

FOLLOW THE ROW RIGHT TO YOUR STUD LENGTH

YOUR STUD LENGTH DIM. 'L'
-045-
-050-
-055-
-060-
-065-
-070-
-075-
-080-
-085-
-090-
-095-
-100-

## RECEPTACLES

### MINI SNAP-IN, BACK INSTALLED 004-012-010 AND 004-013-010



#### INSTALLATION

1. Angle long notched side of top flange into hole from underside.
2. Push other long side completely through with flat blade screwdriver.

#### SUPPORT PREPARATION

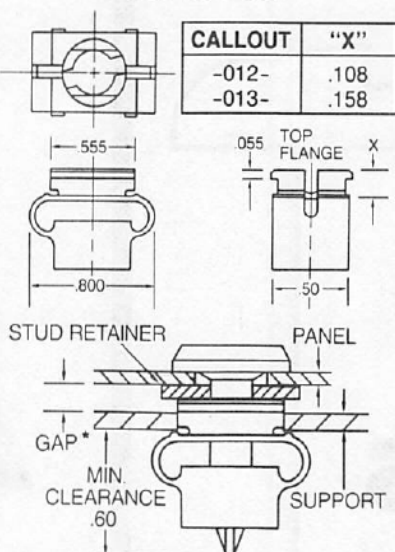
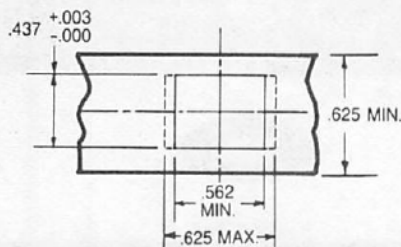

CALLOUT	"X"
-012-	.108
-013-	.158

\*GAP: Combined thickness of receptacle top flange and stud retainer (if used). Note that these parts may also be nested into recessed holes.

CLIP-IN RECEPTACLE MINI REAR LOAD 004-***-010		YOUR STUD LENGTH DIM. 'L'	
FIND YOUR SUPPORT THICKNESS			
.032 to .050	.051 to .100		
FOLLOW ITS COLUMN DOWN TO YOUR RECEPTACLE			
***-012-	***-013-		
THEN TO YOUR PANEL PLUS GAP* THICKNESS		FOLLOW THE ROW RIGHT TO YOUR STUD LENGTH	
.125 to .174	.074 to .124		-045-
.175 to .224	.125 to .174		-050-
.225 to .274	.175 to .224		-055-
.275 to .324	.225 to .274		-060-
.325 to .374	.275 to .324		-065-
.375 to .424	.325 to .374		-070-
.425 to .474	.375 to .424		-075-
.475 to .524	.425 to .474		-080-
.525 to .574	.475 to .524		-085-
.575 to .624	.525 to .574	-090-	
.625 to .674	.575 to .624	-095-	
.675 to .724	.625 to .674	-100-	

### MINI SNAP-IN, TOP INSTALLED 004-911-010 THROUGH 004-915-010

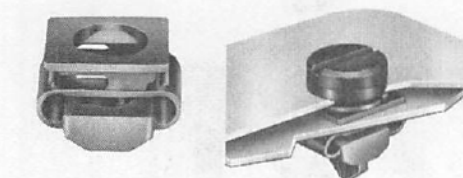

#### INSTALLATION

1. Place open end of top flange around hole edge from above and angle receptacle through hole.
2. Slide receptacle back until flange lip snaps into hole.

#### SUPPORT PREPARATION

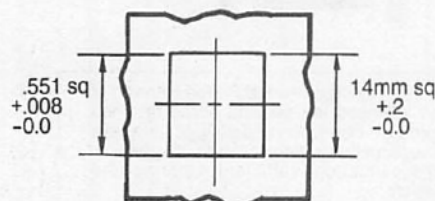

\*GAP: Combined thickness of receptacle top flange and stud retainer (if used). Note that these parts may also be nested into recessed holes.

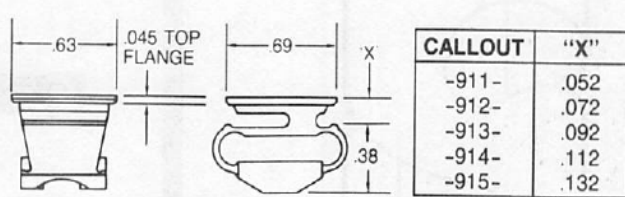

CALLOUT	"X"
-911-	.052
-912-	.072
-913-	.092
-914-	.112
-915-	.132

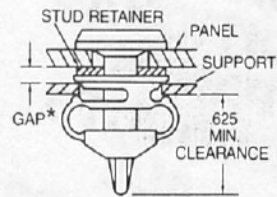

CLIP-IN RECEPTACLE, MINI TOP LOAD -004-***-010					YOUR STUD LENGTH DIM. 'L'	
FIND YOUR SUPPORT THICKNESS						
.035 to .049	.050 to .069	.070 to .089	.090 to .109	.110 to .129		
FOLLOW ITS COLUMN DOWN TO YOUR RECEPTACLE						
***-911-	***-912-	***-913-	***-914-	***-915-		
THEN TO YOUR PANEL PLUS GAP* THICKNESS					FOLLOW THE ROW RIGHT TO YOUR STUD LENGTH	
.105 to .154	.085 to .134	.065 to .114	.045 to .094	.025 to .074		-045-
.155 to .204	.135 to .184	.115 to .164	.095 to .144	.075 to .124		-050-
.205 to .254	.185 to .234	.165 to .214	.145 to .194	.125 to .174		-055-
.255 to .304	.235 to .284	.215 to .264	.195 to .244	.175 to .224		-060-
.305 to .354	.285 to .334	.265 to .314	.245 to .294	.225 to .274		-065-
.355 to .404	.335 to .384	.315 to .364	.295 to .344	.275 to .324		-070-
.405 to .454	.385 to .434	.365 to .414	.345 to .394	.325 to .374		-075-
.455 to .504	.435 to .484	.415 to .464	.395 to .444	.375 to .424		-080-
.505 to .554	.485 to .534	.465 to .514	.445 to .494	.425 to .474		-085-
.555 to .604	.535 to .584	.515 to .564	.495 to .544	.475 to .524		-090-
.605 to .654	.585 to .634	.565 to .614	.545 to .594	.525 to .574		-095-
.655 to .704	.635 to .684	.615 to .664	.595 to .644	.575 to .624	-100-	



Get quote >>

Angic Global Solutions 1-888-872-0690  
<https://www.AngicGlobal.com> Sales@AngicGlobal.com

**FAST**

# DZUS

**FASTENING**

## PANEX LINE

# 1/4 Turn Fasteners

**FOR NEW  
ADDITIONAL  
PANEX  
PRODUCTS  
CALL  
516-669-6003**

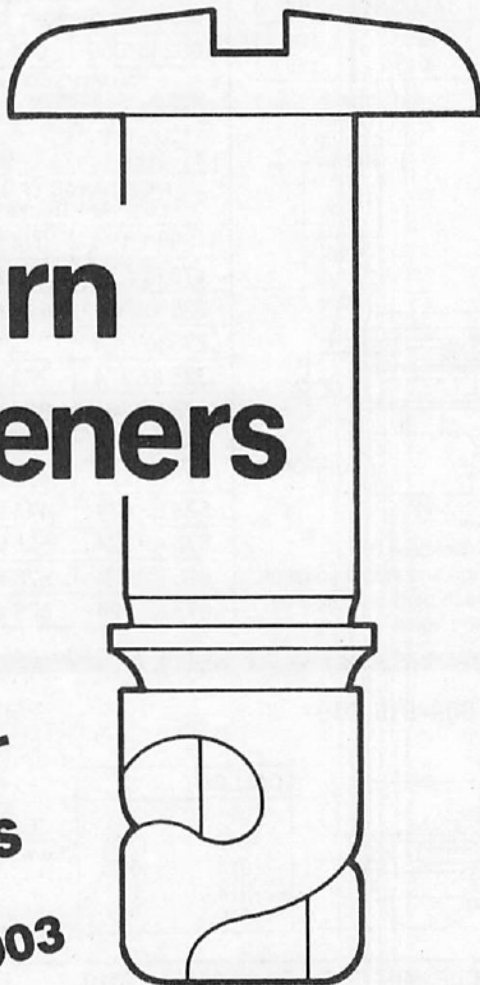

Panex Line is the latest DZUS 1/4-turn range, with all-new spiral slot studs and receptacles. From simplified parts selection and installation procedures, to widened tolerance for material thickness variations, every aspect of Panex Line fasteners has been designed to an optimum level of performance and installed cost for higher-volume commercial applications. With all-metric dimensions and worldwide availability, these fasteners are uniquely suited to multi-national manufacturing programs.

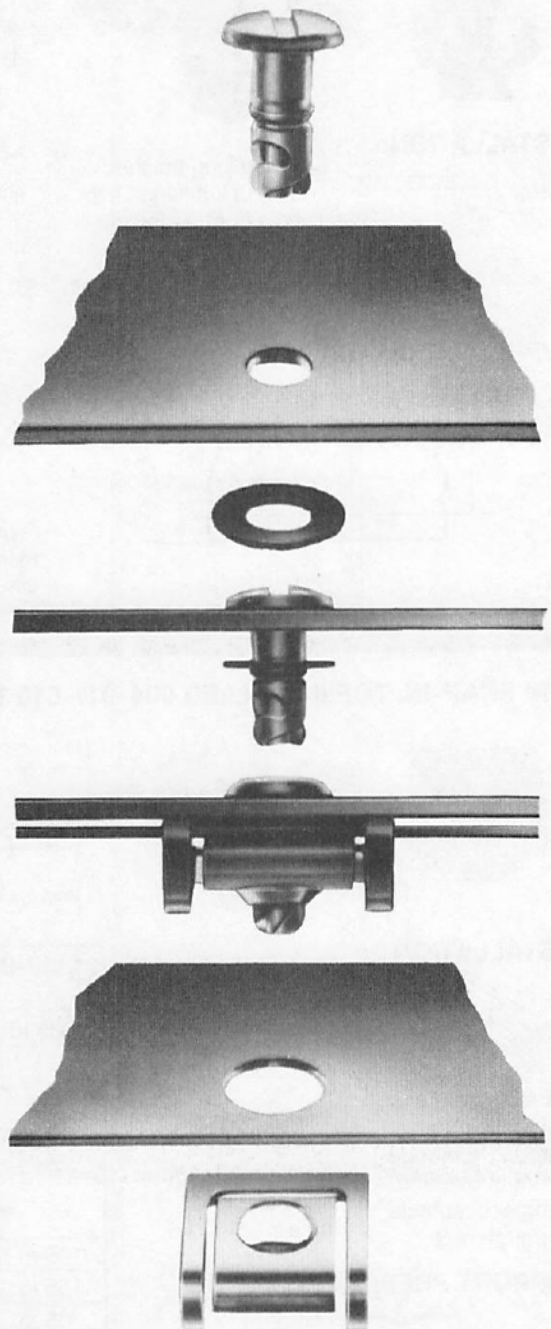

**NOTE** — The selection and installation planning of fasteners can influence the security of the fastened parts. Dzus product information and support service is intended for use only by persons with mechanical engineering qualifications sufficient to manage the responsibilities of:

1. Analyzing fastener performance in relation to the service to be met, and
2. Planning appropriate fastening locations and installations.



# COMPONENTS

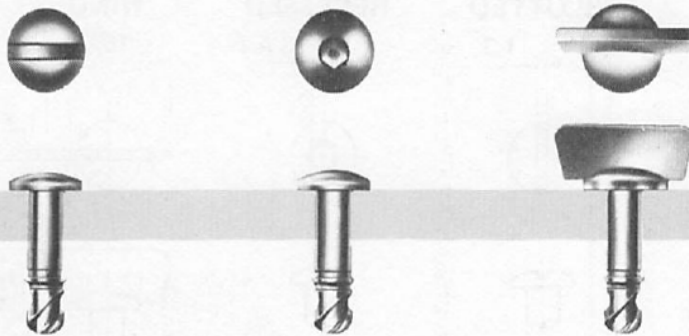

## STUDS

Panex studs are stocked in the U.S. in sizes 4 and 6, referring to the nominal shank diameter in millimeters. The head styles shown above are standard. At the opposite end, a modified DZUS spiral slot engages 2 tabs in the receptacle. Finished in bright zinc with yellow chromate.



## RETAINERS

Stud retention is possible with either a plastic or steel retainer, each being a simple push on installation. Additionally, the plastic retainer may be used as an underhead washer to prevent damage to decorative panels.

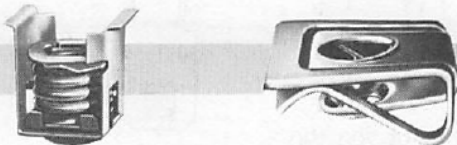

## RECEPTACLES

Panex receptacles are stocked in 2 rapidly-installed styles; a square hole front-load, and an edge-mounted round hole slip-on. Both are available in sizes 4 and 6. Finish is mechanical zinc with yellow chromate.

Panex Line fasteners offer all the advantages of quarter-turn operation, plus uniquely-simple selection and installation procedures, and all-metric dimensions.

With Panex fasteners, the speed and simplicity which are among the distinguishing features of quarter-turn operation may now be applied with equal emphasis to their selection and installation. If the heavy contribution of installation labor to total in-place cost is recognized, it will be apparent that Panex fasteners offer a substantial savings compared with quarter-turns intended for high-stress use. At the same time, their strength, vibration resistance and durability are ample for a wide range of commercial applications.

On internationally produced products, the metric dimensions of Panex components and panel holes, and the worldwide DZUS sales and service network should be of special benefit.



Get quote »

Angic Global Solutions

1-888-872-0690

<https://www.AngicGlobal.com> [Sales@AngicGlobal.com](mailto:Sales@AngicGlobal.com)

## 4mm STUD

PANEL HOLE  $\varnothing 5,0 \pm 0,2$

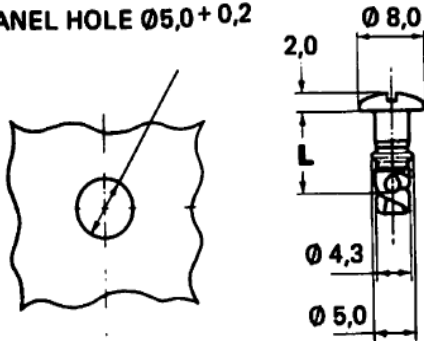

Material:- Case Hardened Steel

Finish:- Zinc Plate & Chromate Passivation

**SLOTTED**

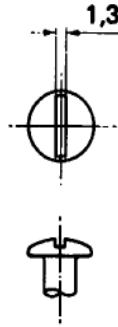

314-1 L-190

**RECESSED**

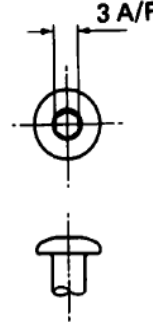

314-2 L-190

**WING**

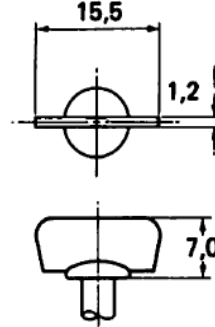

314-3 L-190

## 4mm FRONT LOAD RECEPTACLE

SUPPORT RANGE (Q) 0,7 TO 2,5

SUPPORT PREPARATION

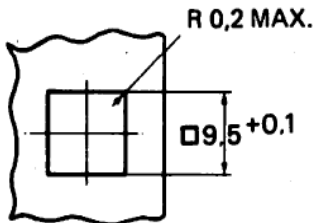

Material:- Spring Steel

Finish:- Mechanical Zinc Plate & Chromate Passivation

Max. Load Without Distortion: 50N

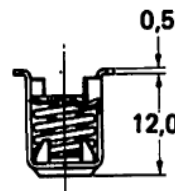
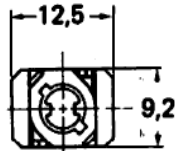

PART NO 334-200-190

**INSTALLATION PROCEDURE**

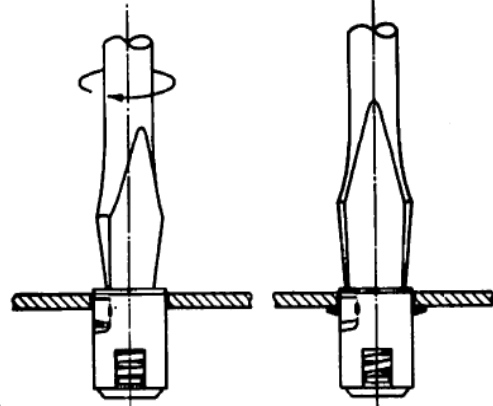

PRESS & TURN    INSTALLED POSITION

## 4mm FRONT LOAD-STUD SELECTOR CHART

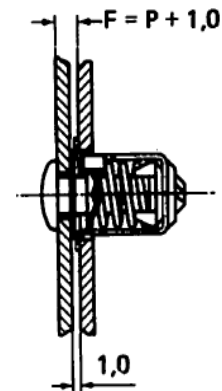
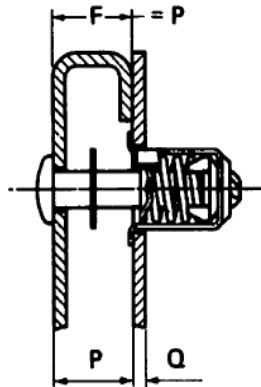
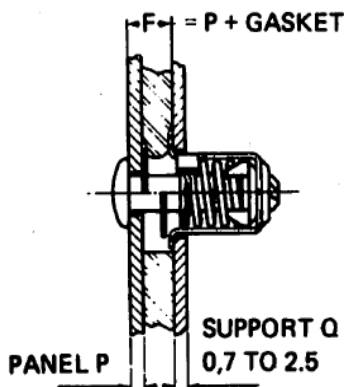

NOTE:- L DIMENSION TO BE INSERTED INTO STUD PART NUMBER, SEE ABOVE

F DIMENSION	L	F DIMENSION	L	F DIMENSION	L
1,5 - 2,4	12	6,5 - 7,4	17	10,5 - 11,4	21
2,5 - 3,4	13	7,5 - 8,4	18	11,5 - 12,4	22
3,5 - 4,4	14	8,5 - 9,4	19	12,5 - 13,4	23
4,5 - 5,4	15	9,5 - 10,4	20	13,5 - 14,4	24
5,5					

# COMPONENTS

## 4mm RETAINERS

### PLASTIC RETAINER

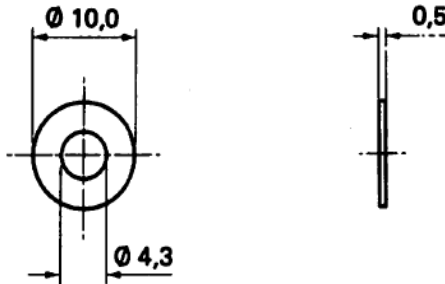

PART NO. 324-100-040

Material:- High Density Polythene

Colour:- Natural

### STEEL RETAINER

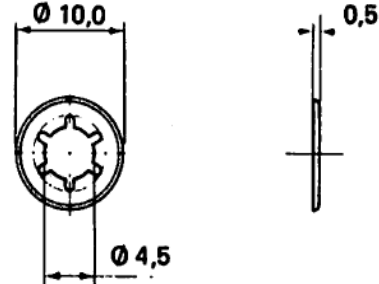

PART NO. 324-101-190

Material:- Spring Steel

Finish:- Mechanical Zinc Plate & Chromate Passivation

## 4mm SLIP ON RECEPTACLE

SUPPORT RANGE (Q) 0,7 TO 2,5

SUPPORT PREPARATION

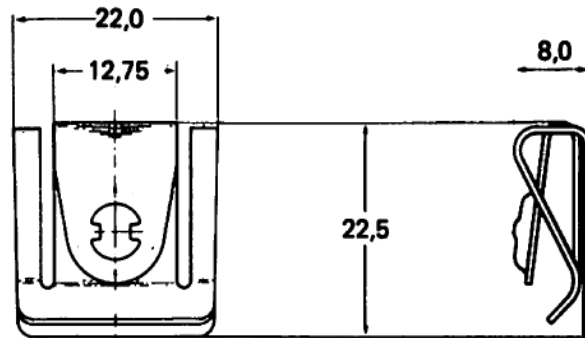
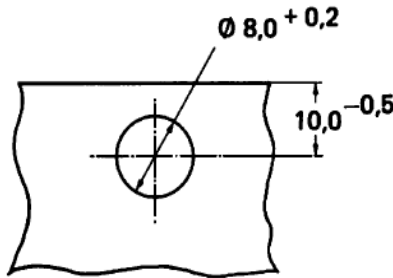

Material:- Spring Steel

Finish:- Mechanical Zinc Plate & Chromate Passivation

PART NO. 334-300-190

Max. Load Without Distortion: 130N

## 4mm SLIP ON-STUD SELECTOR CHART

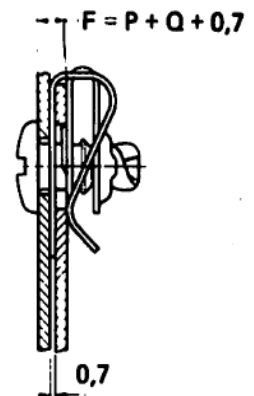
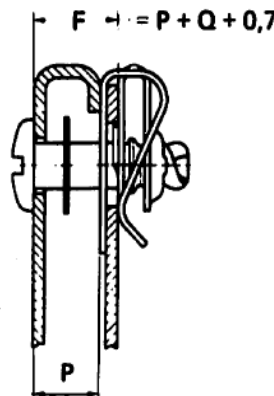
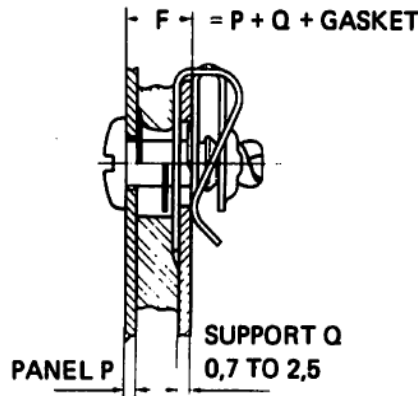

NOTE: - L DIMENSION TO BE INSERTED INTO STUD PART NUMBER, SEE PAGE 62 TOP

F DIMENSION	L	F DIMENSION	L	F DIMENSION	L
1,5 - 2,4	08	6,5 - 7,4	13	10,5 - 11,4	17
2,5 - 3,4	09	7,5 - 8,4	14	11,5 - 12,4	18
3,5 - 4,4	10	8,5 - 9,4	15	12,5 - 13,4	19
4,5		10,4			
5,5					



Get quote >>

Angic Global Solutions

1-888-872-0690

<https://www.AngicGlobal.com> Sales@AngicGlobal.com

## 6mm STUD

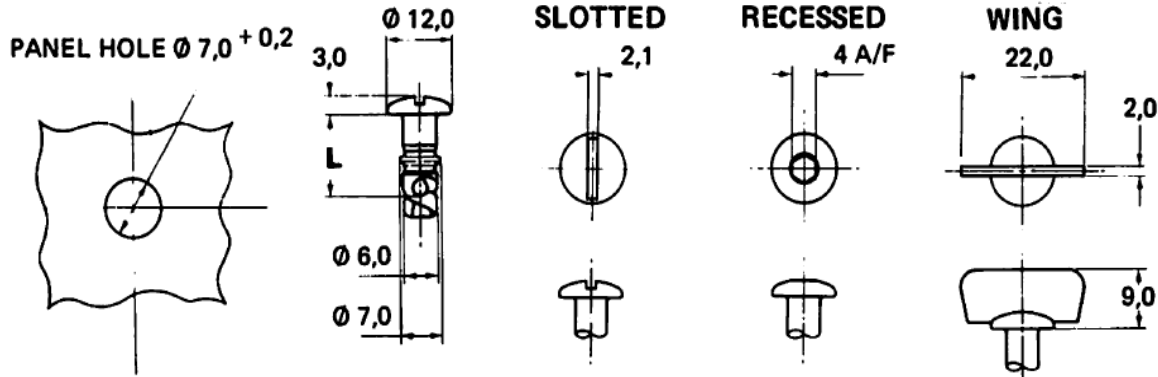

Material:- Case Hardened Steel  
Finish:- Zinc Plate & Chromate Passivation

316-1 L-190

316-2 L-190

316-3 L-190

## 6mm FRONT LOAD RECEPTACLE

SUPPORT RANGE (Q) 0,7 TO 3,2

SUPPORT PREPARATION

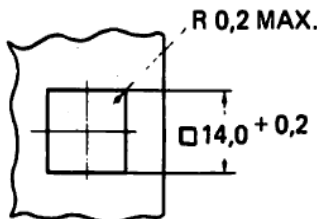

Material:- Spring Steel

Finish:- Mechanical Zinc Plate & Chromate Passivation

Max. Load Without Distortion: 80N

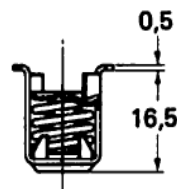
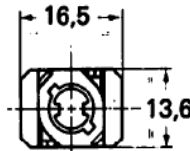

PART NO. 336-200-190

### INSTALLATION PROCEDURE

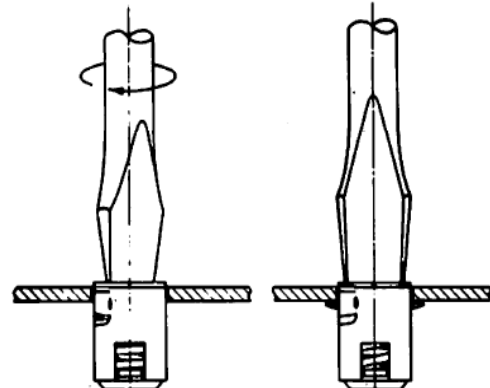

PRESS & TURN    INSTALLED POSITION

## 6mm FRONT LOAD-STUD SELECTOR CHART

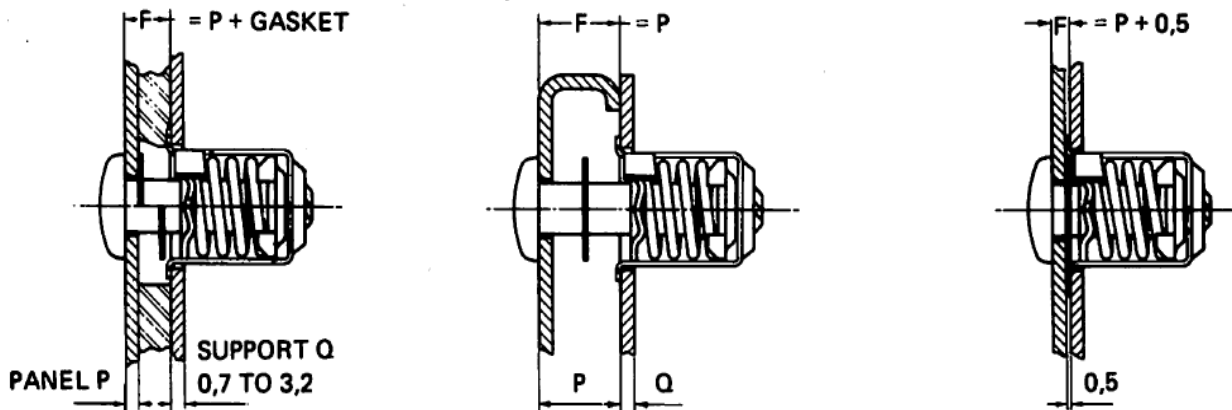

NOTE:- L DIMENSION TO BE INSERTED INTO STUD PART NUMBER, SEE ABOVE.

F DIMENSION	L	F DIMENSION	L	F DIMENSION	L
0,8 - 1,7	16	5,8 - 6,7	21	9,8 - 10,7	25
1,8 - 2,7	17	6,8 - 7,7	22	10,8 - 11,7	26
2,8 - 3,7	18	7,8 - 8,7	23	11,8 - 12,7	27
3,8 - 4,7	19	8,8 - 9,7	24	12,8 - 13,7	28

# COMPONENTS



## 6mm RETAINERS

PLASTIC RETAINER

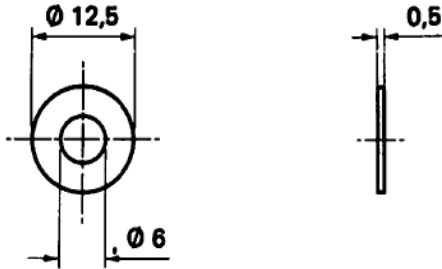

PART NO. 326-100-040

Material:- High Density Polythene  
Colour:- Natural

STEEL RETAINER

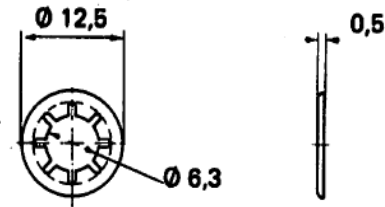

PART NO. 326-101-190

Material:- Spring Steel  
Finish:- Mechanical Zinc Plate & Chromate Passivation

## 6mm SLIP ON RECEPTACLE

SUPPORT RANGE (Q) 0,7 TO 3,2

SUPPORT PREPARATION

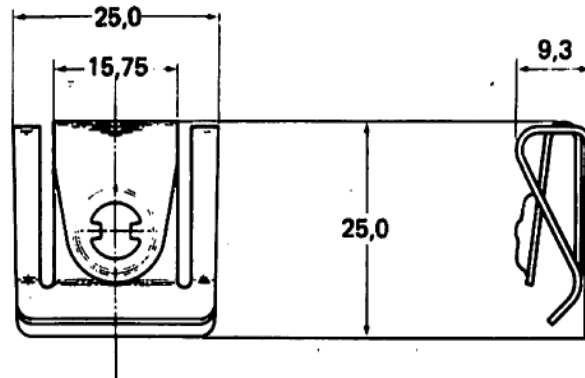
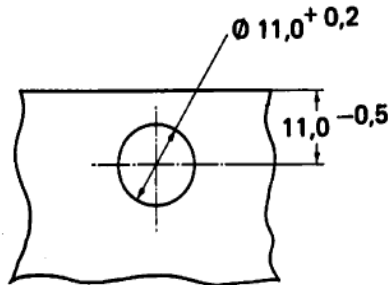

Material:- Spring Steel

Finish:- Mechanical Zinc Plate & Chromate Passivation PART NO. 336-300-190

Max. Load Without Distortion: 220N

## 6mm SLIP ON-STUD SELECTOR CHART

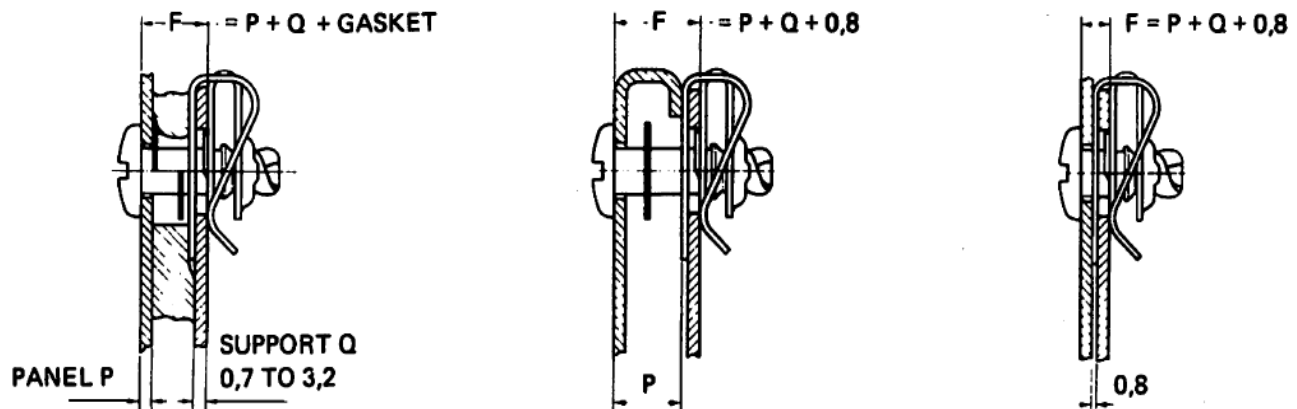

NOTE: - L DIMENSION TO BE INSERTED INTO STUD PART NUMBER, SEE PAGE 64 TOP

F DIMENSION	L	F DIMENSION	L	F DIMENSION	L
1,5 - 2,4	09	6,5 - 7,4	14	10,5 - 11,4	18
2,5 - 3,4	10	7,5 - 8,4	15	11,5 - 12,4	19
3,5 - 4,4	11	8,5 - 9,4	16	12,5 - 13,4	20
4,5 - 5,4	12	9,5 - 10,4	17	13,5 - 14,4	21
5,5					



Get quote >>

Angic Global Solutions

1-888-872-0690

<https://www.AngicGlobal.com> [Sales@AngicGlobal.com](mailto:Sales@AngicGlobal.com)

# Quick-Acting Threaded Fasteners

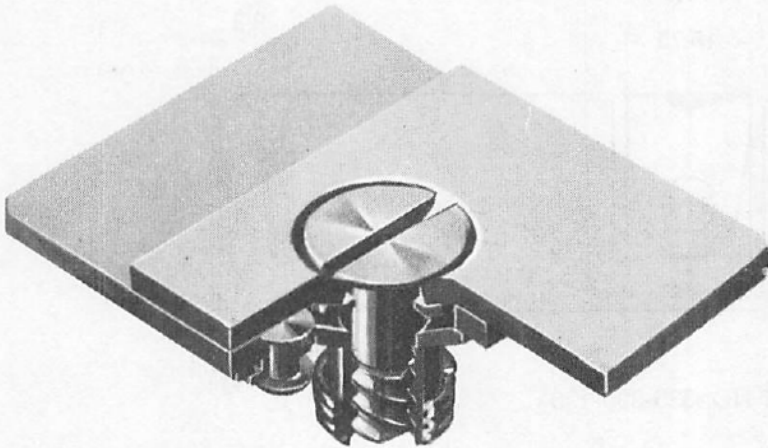

The Universal Line stud has a special four-lead thread that operates in less than one turn. The receptacle provides a friction lock by expanding against a surrounding coil spring as the stud is engaged.

Rated locking torque is maintained over thousands of use cycles. These features are combined with the advantages of standard threaded fasteners; panel take-up, no sheet separation under load, and high tensile and shear ratings.



**NOTE** —The selection and installation planning of fasteners can influence the security of the fastened parts. Dzus product information and support service is intended for use only by persons with mechanical engineering qualifications sufficient to manage the responsibilities of:

1. Analyzing fastener performance in relation to the service to be met, and
2. Planning appropriate fastening locations and installations.

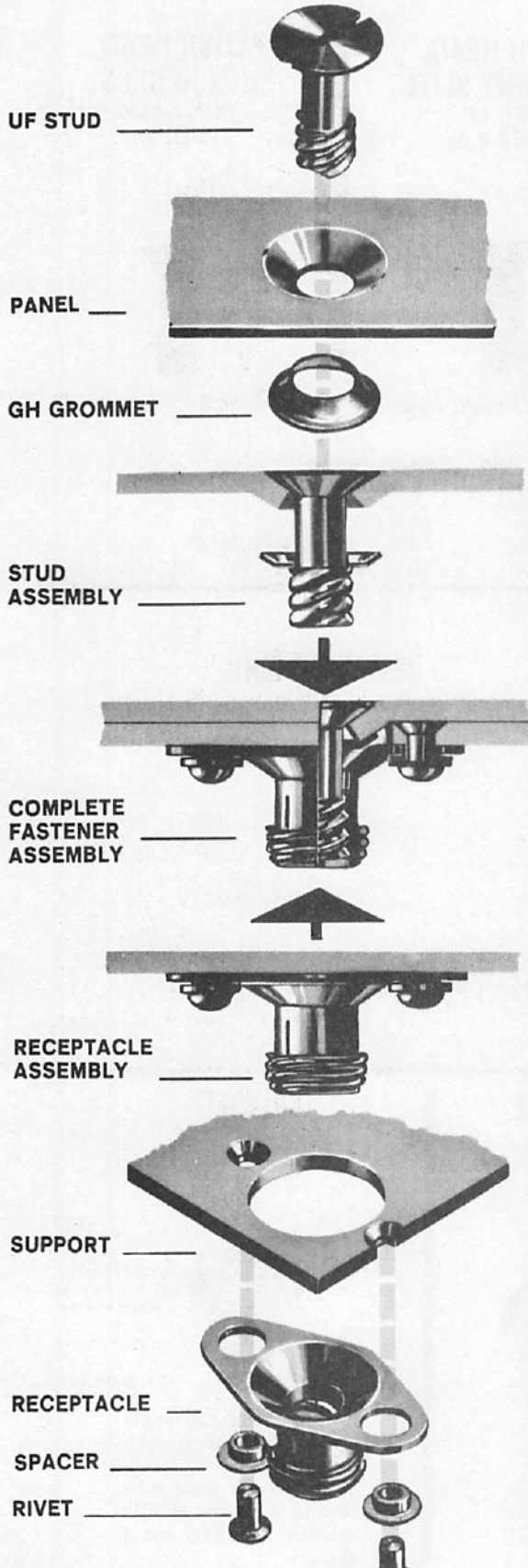

**STUDS**  
**RETAINERS**  
**RECEPTACLES**

The fastener stud has a fast four lead thread, and is easily captivated in the panel with a grommet which is slipped over the threaded end and flattened down. Studs are made of steel, heat treated and cadmium plated per QQ-P-416, Type 1, Class 3. Other materials on special order.

The Type GH half grommets used with the Universal fastener are made of aluminum or steel cadmium plated. The retaining rings are made of steel cadmium plated per QQ-P-416, Type II, Class 2.

Two types of receptacles are available—rigid and floating (the latter for use where misalignment may develop). The receptacle is slotted and spring encircled. As the stud is screwed into the receptacle, the spring is expanded, thus creating a constricting force on the stud. The receptacle is made of aluminum alloy, anodized, and the spring is made of music wire, cadmium plated per QQ-P-416, Type II, Class 2. Spacers for all floating receptacles are made of steel, cadmium plated per QQ-P-416, Type II, Class 2. Other materials on special order.

**HEX HEAD**  
TYPE UH



**OVAL HEAD, STRAIGHT SLOT**  
TYPE UA

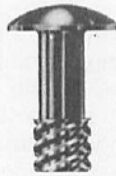

**FLUSH HEAD, STRAIGHT SLOT**  
TYPE UF  
(SIZES 4, 5)



**FLUSH HEAD, HEX RECESS**  
TYPE UFSH  
(SIZE 3)



Studs are available with Hex, Oval-Slotted, and Flush-Slotted Heads. Available on special order: Oval Head Studs with Phillips Recess.

Universal Size	Thread Major Dia.	Locking Torque	Rated Tensile And Shear	Locking Torque Retention
3	3/16"	4-8 In.Lb.	600 Lb.	5000 Cycles
4	1/4"	8-12 In.Lb.	1000 Lb.	5000 Cycles
5	5/16"	15-25 In.Lb.	1500 Lb.	5000 Cycles

**HALF GROMMET**  
TYPE GH



The GH Half Grommet slips over the Stud End and provides rugged retention when flattened with a simple Dzus Tool.

**RETAINING RING**  
TYPE WA & Y166 (for size 3)



Retaining Rings are slipped around the Stud and squeezed closed with pliers.

**RIGID RECEPTACLE**  
TYPES UR & URA

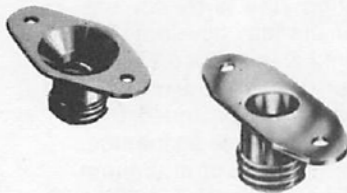

Rigid receptacles are riveted solidly to their support. Type URA is used for size 3 and 4 studs. Type UR is used for size 5 studs only.

**FLOATING RECEPTACLE**  
TYPES URF & URFA

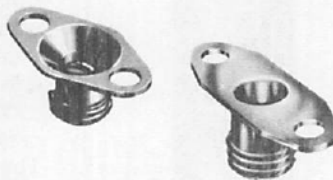

Floating receptacles have oversize rivet holes that permit movement around rivet spacers within the holes. Supplied with 2 spacers.

**PRESTFIT RECEPTACLE**  
TYPE URFP



Press-In Receptacles are installed by pressing into a round hole. Receptacles float to accept panel misalignment. Type URFP is available for size 3 and 4 studs.

# SIZE 3 HEX, OVAL & FLUSH HEAD STUDS

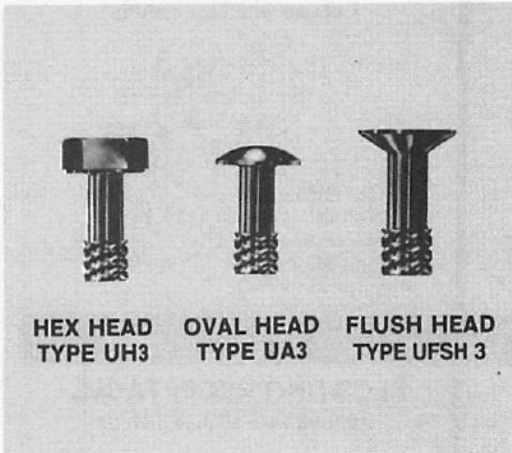

**HEX HEAD TYPE UH3**    **OVAL HEAD TYPE UA3**    **FLUSH HEAD TYPE UFSH 3**

These size 3 hex, oval and flush head studs are supplied with 3/16" thread major diameter. The locking torque is 4 to 8 inch pounds. 600 Lb. rated tensile and shear.

Stud Material: steel, heat treated, cadmium plated QQ-P-416, Type 1, Class 3

## HEX HEAD TYPE UH3

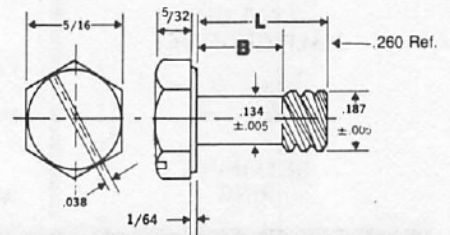

## OVAL HEAD TYPE UA3

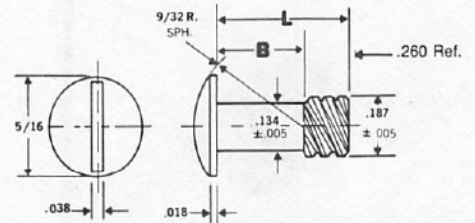

## FLUSH HEAD TYPE UFSH 3

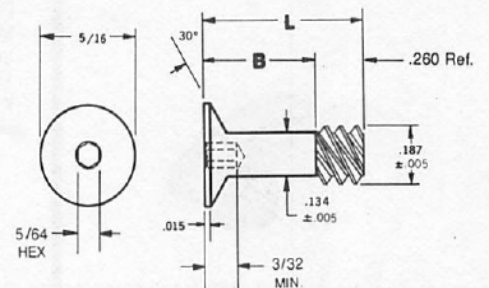

Material Thickness "T"	Hex. Head Studs		Oval Head Studs		Flush Head		B Dim.	L Dim.
	Part No.	Weight	Part No.	Weight	Part No.	Weight		
.000-.050	UH3T5	.0060	UA3T5	.00304	—	—	.160	.420
.051-.100	UH3T10	.0062	UA3T10	.00324	—	—	.210	.470
.101-.150	UH3T15	.0064	UA3T15	.00344	UFSH3T15*	.00308	.260	.520
.151-.200	UH3T20	.0066	UA3T20	.00364	UFSH3T20	.00328	.310	.570
.201-.250	UH3T25	.0068	UA3T25	.00384	UFSH3T25	.00348	.360	.620
.251-.300	UH3T30	.0070	UA3T30	.00404	UFSH3T30	.00368	.410	.670
.301-.350	UH3T35	.0072	UA3T35	.00424	UFSH3T35	.00388	.460	.720
.351-.400	UH3T40	.0074	UA3T40	.00444	UFSH3T40	.00408	.510	.770

\*Min. panel thickness — .125

Note: A thread lubricant suitable for the fastener's installed environment is recommended.

### TYPICAL ASSEMBLY

Add your panel and support thickness to give you the "T" dimension. Then select stud from chart above.

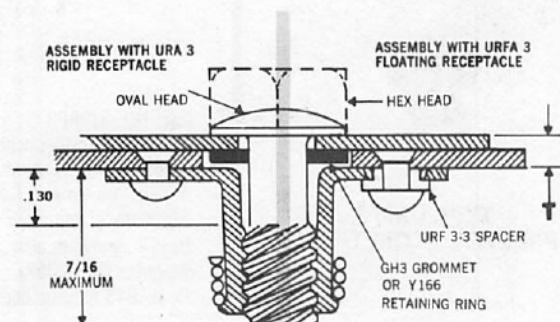

Get quote >>

Angic Global Solutions

1-888-872-0690

<https://www.AngicGlobal.com>    [Sales@AngicGlobal.com](mailto:Sales@AngicGlobal.com)

**STUD RETAINERS**



**TYPE GH HALF GROMMET**



**RETAINING RING**

**TYPE GH HALF GROMMET**

For use with all size 3 studs

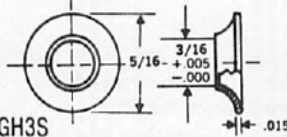

Part No.: GH3S

Material: Steel, cadmium plated with yellow chromate, per QQ-P-416, Type II, Class 2

Weight in lbs.: .00028

**RETAINING RING**

For use with size 3 studs

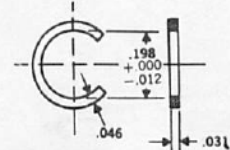

Part No.: Y166

Material: steel, cadmium plated, yellow chromate finish, QQ-P-416, Type 2, Class 2

Weight in lbs.: .00025

**RECEPTACLES**



**TYPE URA3 RIGID RECEPTACLE**



**TYPE URFA3 FLOATING RECEPTACLE**



**TYPE URFP3 PRESTFIT RECEPTACLE**

**RIGID RECEPTACLE**

For use with all size 3 studs

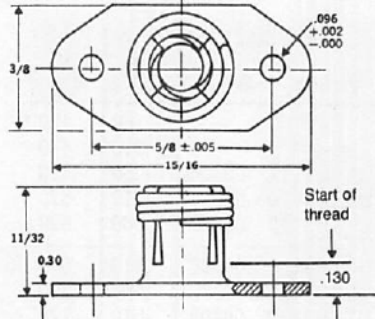

Part No.: URA 3

Material: Aluminum alloy, anodized. Spring—music wire cadmium plated—Type II, Class 2, Yellow

Weight in lbs.: .0026

**FLOATING RECEPTACLE**

For use with all size 3 studs

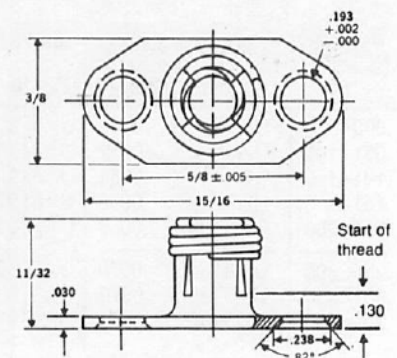

Part No.: URFA3

Material: aluminum alloy, anodized. Spring—music wire, Cadmium plated—Type II, Class 2, Yellow

Weight in lbs.: .0033 (including 2 spacers)

Float: .025 All Directions

**PRESTFIT RECEPTACLE**

For use with size 3 studs

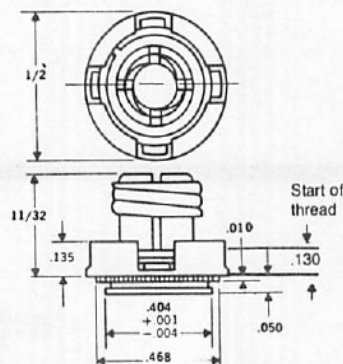

Part NO.: URFP3

Material: Ring—carbon spring steel, heat treated Retainer—steel, heat treated

Spring—music wire. Ring, retainer and spring all cadmium plated QQ-P-416, Type II, Class 2, Yellow

Base—aluminum alloy, anodized

Weight in lbs.: .00577

Float: .015 All Directions

**SPACER**

For use with URFA3 Receptacle  
 2 supplied with each URFA3 receptacle

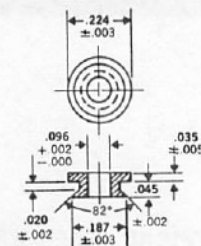

Part No.: URF3-3

Material: Steel cadmium, plated QQ-P-416, Type II, Class 2, Yellow

Weight in lbs.: (included with receptacle)

# SIZE 4 HEX, OVAL & FLUSH HEAD STUDS

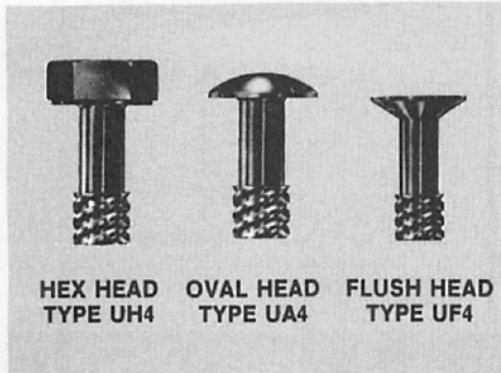

These size 4 hex and oval head studs are supplied with 1/4" thread major diameter. The locking torque is 8 to 12 inch pounds. 1000 lb. rated tensile and shear.

Stud Material: steel, heat treated, cadmium plated QQ-P-416, Type 1, Class 3

### HEX HEAD TYPE UH4

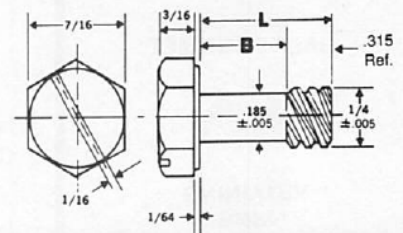

### OVAL HEAD TYPE UA4

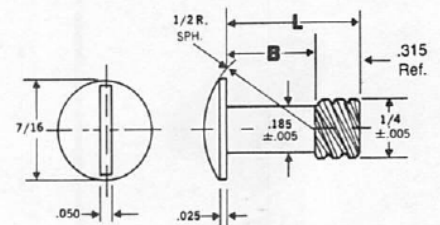

### FLUSH HEAD TYPE UF4

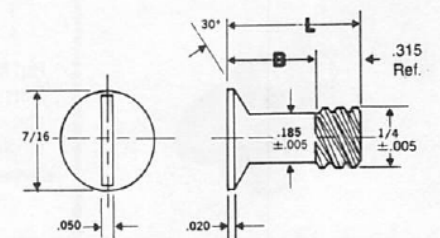

Material Thickness "T"	Hex. Head Studs		Oval Head Studs		Flush Head		B Dim.	L Dim.
	Part No.	Weight	Part No.	Weight	Part No.	Weight		
.000-.100	UH4T10	.01392	UA4T10	.00675	—	—	.250	.565
.101-.200	UH4T20	.01469	UA4T20	.00752	UF4T20*	.00751	.350	.665
.201-.300	UH4T30	.01546	UA4T30	.00829	UF4T30	.00828	.450	.765
.301-.400	UH4T40	.01623	UA4T40	.00906	UF4T40	.00906	.550	.865
.401-.500	UH4T50	.01700	UA4T50	.00983	UF4T50	.00983	.650	.965
.501-.600	UH4T60	.01777	UA4T60	.01060	UF4T60	.01060	.750	1.065
.601-.700	UH4T70	.01854	UA4T70	.01137	UF4T70	.01137	.850	1.165
.701-.800	UH4T80	.01931	UA4T80	.01214	UF4T80	.01214	.950	1.265

\*Min. Panel Thickness — .150

Note: A thread lubricant suitable for the fasteners' installed environment is recommended.

### TYPICAL ASSEMBLY

Add your panel and support thickness to give you the "T" dimension. Then select stud from chart above.

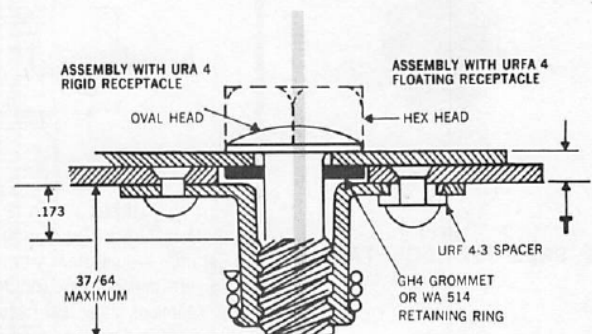

Get quote »

Angic Global Solutions

1-888-872-0690

<https://www.AngicGlobal.com> [Sales@AngicGlobal.com](mailto:Sales@AngicGlobal.com)

**STUD RETAINERS**



**GH HALF GROMMET**  
 For use with all size 4 studs

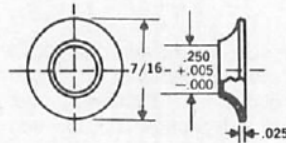

Part No.: GH4S  
 Material: Steel, cadmium plated with yellow chromate, per QQ-P-416, Type II, Class 2  
 Weight in lbs.: .00094

**RETAINING RING**  
 For use with all size 4 studs

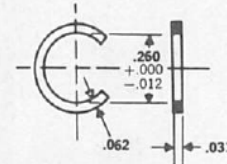

Part No.: WA514  
 Material: steel, cadmium plated, yellow chromate finish, QQ-P-416, Type 2, Class 2  
 Weight: .00042

**RECEPTACLES**

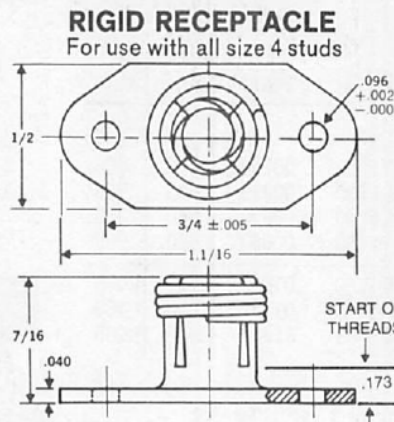

Part No.: URA4  
 Material: aluminum alloy, anodized. Spring—music wire Cadmium plated—Type II, Class 2, Yellow  
 Weight in lbs.: .00516

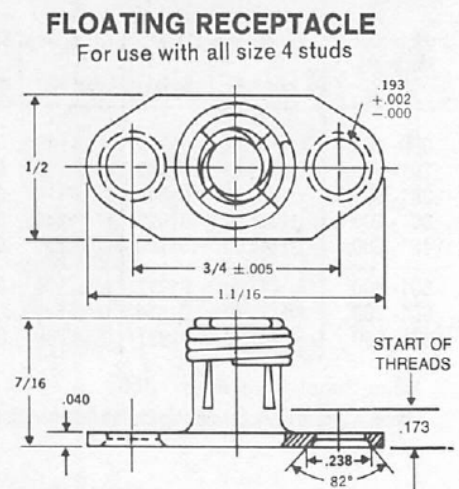

Part No.: URFA4  
 Material: aluminum alloy, anodized. Spring—music wire cadmium plated Type II, Class 2, Yellow  
 Weight in lbs.: .00593 (including 2 spacers)  
 Float: .025 All Directions

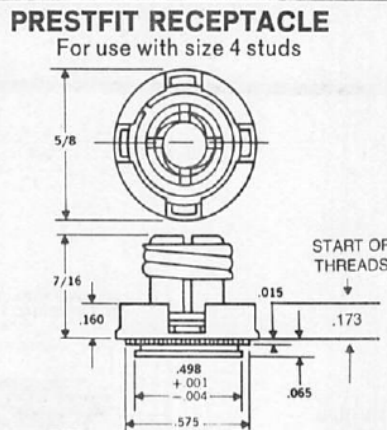
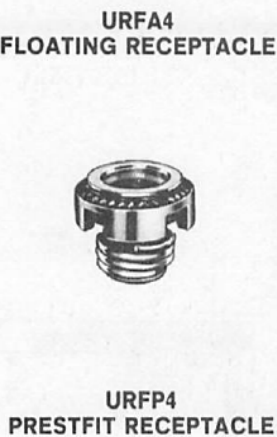

Part No.: URFP4  
 Material: Ring—carbon spring steel, heat treated Retainer—steel heat treated Spring—music wire. Ring retainer and spring all cadmium plated QQ-P416, Type II, Class 2, Yellow Base—aluminum alloy, anodized  
 Weight in lbs.: .01156  
 Float: .015 All Directions

**SPACER**  
 For use with URFA4 Floating Receptacle  
 2 supplied with each receptacle

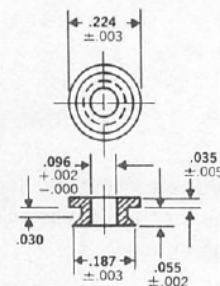

Part No.: URF4-3  
 Material: steel, cadmium plated QQ-P-416, Type II, Class 2 Yellow  
 Weight in lbs.: (included with receptacle)

# SIZE 5 HEX, OVAL & FLUSH HEAD STUDS

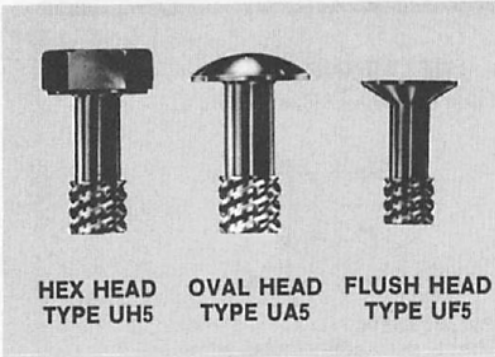

These size 5 hex, oval and flush head studs are supplied with 5/16" thread major diameter. The locking torque is 15 to 23 inch pounds. 1500 Lb. rated tensile and shear.

Stud Material: steel—heat treated, cadmium plated QQ-P-416, Type 1 Class 3

## HEX HEAD TYPE UH5

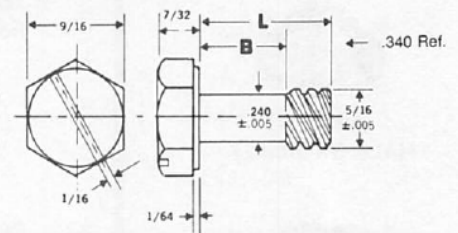

## OVAL HEAD TYPE UA5

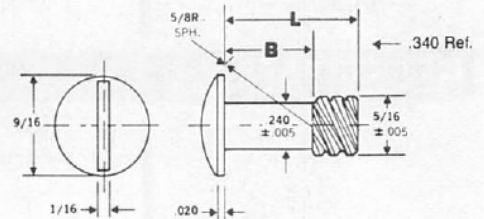

## FLUSH HEAD TYPE UF5

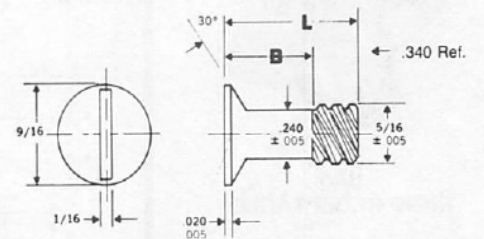

Material Thickness "T"	Hex. Head Studs		Oval Head Studs		Flush Head		B Dim.	L Dim.
	Part No.	Weight	Part No.	Weight	Part No.	Weight		
.000-.100	UH5T10	.02555	UA5T10	.01335	UF5T10	.01311	.360	.700
.101-.200	UH5T20	.02687	UA5T20	.01467	UF5T20	.01443	.460	.800
.201-.300	UH5T30	.02819	UA5T30	.01599	UF5T30	.01575	.560	.900
.301-.400	UH5T40	.02951	UA5T40	.01731	UF5T40	.01707	.660	1.000
.401-.500	UH5T50	.03083	UA5T50	.01863	UF5T50	.01839	.760	1.100
.501-.600	UH5T60	.03215	UA5T60	.01995	UF5T60	.01971	.860	1.200
.601-.700	UH5T70	.03479	UA5T70	.02127	UF5T70	.02103	.960	1.300
.701-.800	UH5T80	.03611	UA5T80	.02259	UF5T80	.02235	1.060	1.400

Note: A thread lubricant suitable for the fastener's installed environment is recommended.

### TYPICAL ASSEMBLY

Add your panel and support thickness to give you the "T" dimension. Then select stud from chart above.

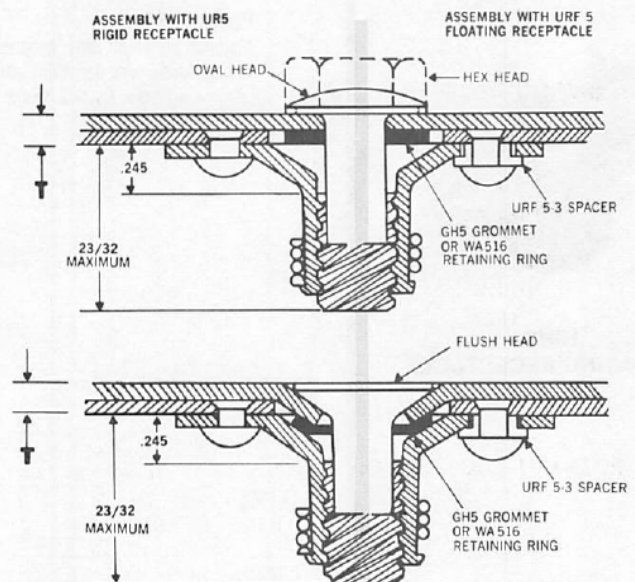

Get quote »

Angic Global Solutions

1-888-872-0690

<https://www.AngicGlobal.com> [Sales@AngicGlobal.com](mailto:Sales@AngicGlobal.com)

**STUD RETAINERS**



**GH HALF GROMMET**

For use with all size 5 studs

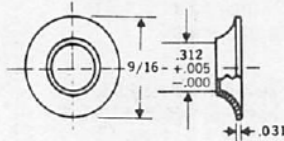

Part No.: GH5S  
 Material: Steel, cadmium plated with yellow chromate finish, per QQ-P-416, Type II, Class 2  
 Weight in Lbs.: .00175

**RETAINING RING**

For use with all size 5 studs

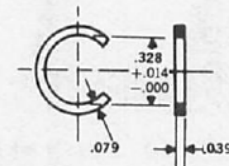

Part No.: WA516  
 Material: steel, cadmium plated, yellow chromate finish, QQ-P-416, Type 2, Class 2  
 Weight: .00094

**RECEPTACLES**



**RIGID RECEPTACLE**

For use with all size 5 studs

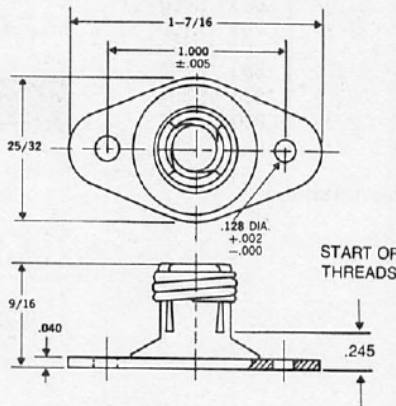

Part No.: UR5  
 Material: aluminum alloy, anodized  
 Spring: Music wire Cadmium plated—Type II, Class 2 Yellow  
 Weight in lbs.: .0092



**FLOATING RECEPTACLE**

For use with all size 5 studs

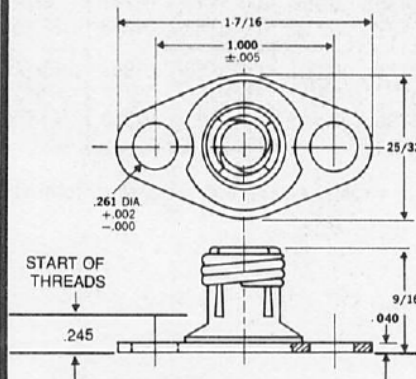

Part No.: URF5  
 Material: aluminum alloy, anodized  
 Spring: music wire. Cadmium Plated—Type II, Class 2 Yellow  
 Weight in lbs.: .01000 (including 2 spacers)  
 Float: .037 All Directions

**SPACER**

For use with URF5 Receptacle  
 2 supplied with each receptacle

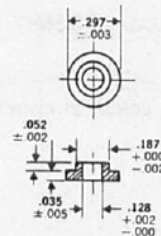

Part No.: URF5-3  
 Material: steel cadmium plated QQ-P-416, Type II, Class 2 Yellow  
 Weight in lbs.: (included with receptacle)

UNIVERSAL LINE  
 INSTALLATION

**STUDS INSTALLATION**

WITH TYPE GH HALF GROMMET

(For retaining ring use, see Prestfit Receptacle Data, next page).

**HEX HEAD STUDS**

**1**

DRILL HOLE



Stud Size	Hole Diameter
3	3/16
4	1/4
5	5/16

**2**

INSERT STUD AND SLIP GROMMET OVER THREAD END

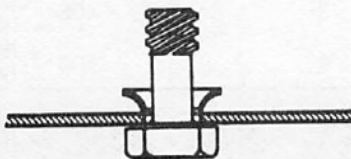

**3**

FLATTEN GROMMET

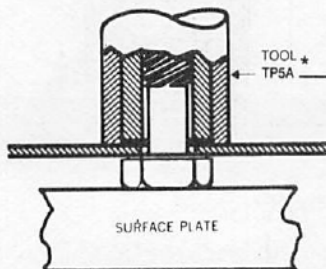

**OVAL HEAD STUDS**

**1**

DRILL HOLE



Stud Size	Hole Diameter
3	3/16
4	1/4
5	5/16

**2**

INSERT STUD AND SLIP GROMMET OVER THREAD END

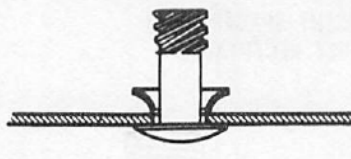

**3**

FLATTEN GROMMET

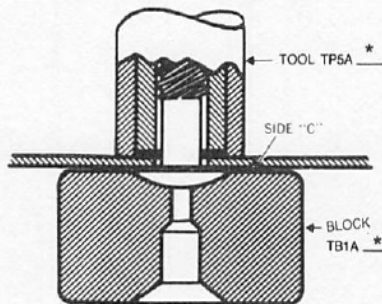

**FLUSH HEAD STUDS**

**1**

DRILL 19/64 HOLE AND DIMPLE

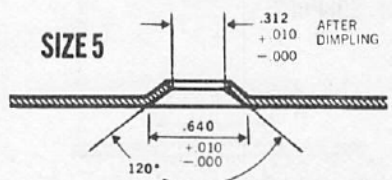

**2**

INSERT STUD AND SLIP GROMMET OVER THREAD END

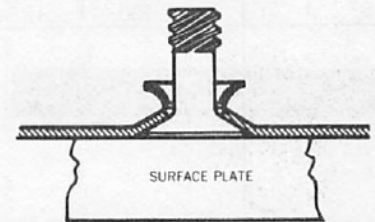

**3**

CLINCH GROMMET

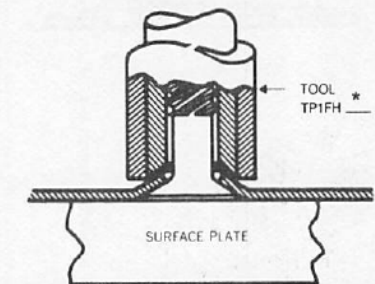

**FLUSH HEAD STUD SIZES 3 & 4**

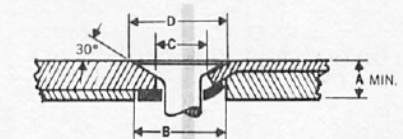

Size	A	B	C	D
3	.125	11/32	3/16	23/64
4	.150	15/32	1/4	31/64

Right side repeat steps 2 & 3  
 Left side repeat steps 2 & 3 using tool TP5A \*

\*ADD SIZE NUMBER TO COMPLETE TOOL CALL OUT

RECEPTACLE INSTALLATION

RIGID RECEPTACLE

1

DRILL HOLES AND  
 COUNTERSINK RIVET HOLES  
 OF SUPPORT

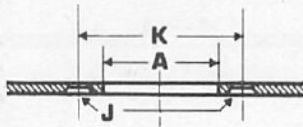

Stud Size	A ±.010	K ±.005	J
3	.344	.625	.096
4	.468	.750	.096
5	.703	1.000	.128

2

RIVET RECEPTACLE



FLOATING RECEPTACLE

1

DRILL HOLES AND  
 COUNTERSINK RIVET HOLES  
 OF SUPPORT



Stud Size	A ±.010	K ±.005	J
3	.344	.625	.096
4	.468	.750	.096
5	.703	1.000	.128

2

INSERT SPACERS AND  
 RIVET RECEPTACLE



PRESTFIT RECEPTACLE

1

DRILL HOLE



Receptacle Size	Hole Diameter
3	.406 +.003 -.001
4	.500 +.003 -.000

2

DRIVE IN RECEPTACLE

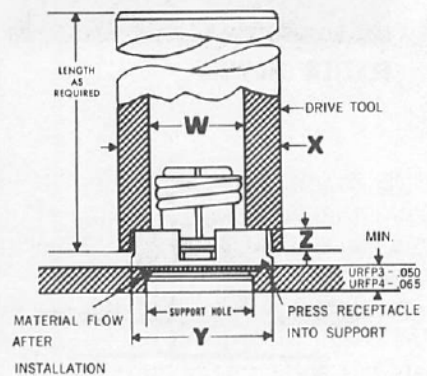

Part No.	Tool Dimensions			
	W	X	Y +.005 -.000	Z
URFP3	1 1/32 x 5/8 deep	5/8	.505	1/8
URFP4	2 3/64 x 5/8 deep	3/4	.630	5/12

# TOGGLE LATCHES

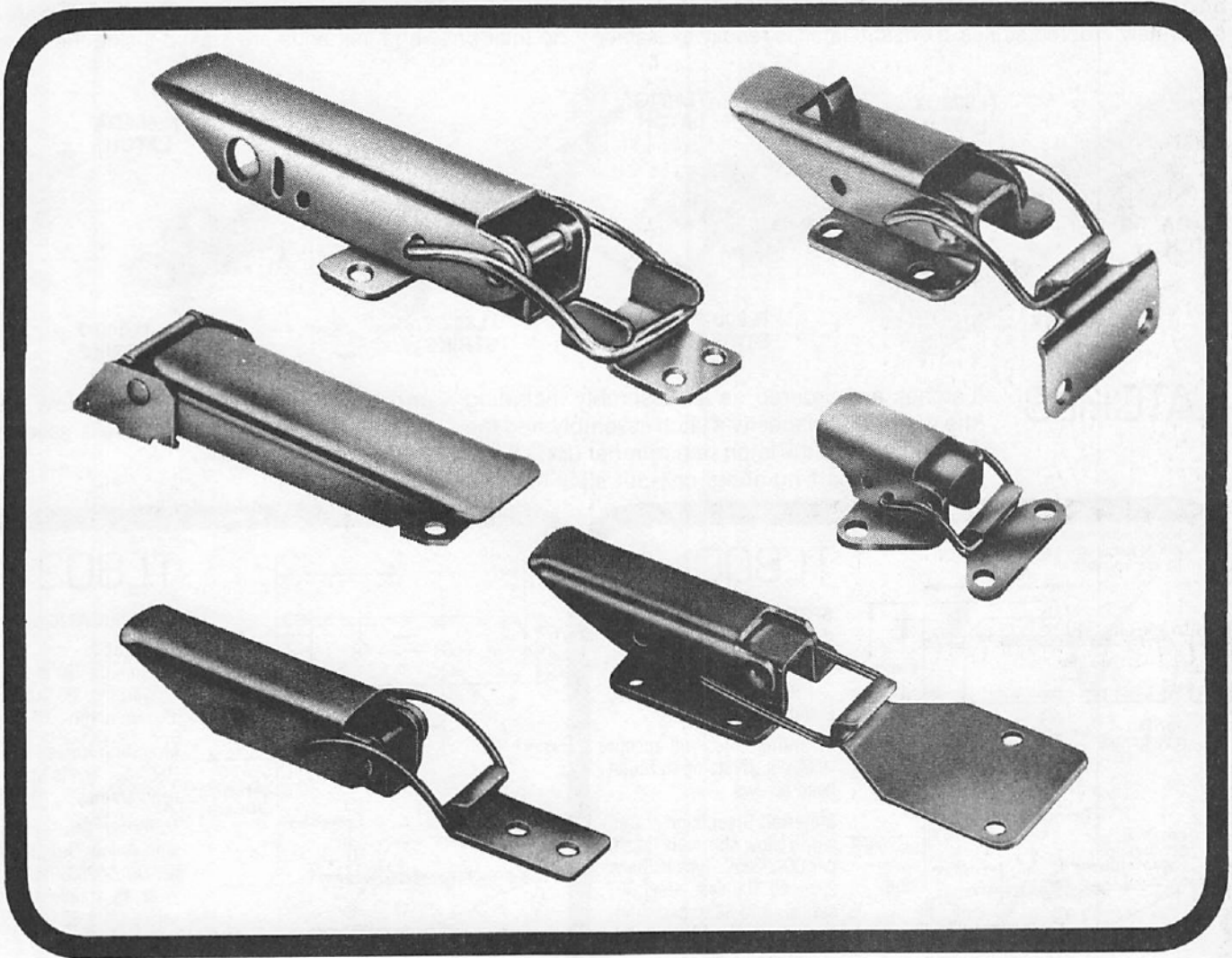

DZUS Toggle Latches provide take-up under mechanical advantage in plane with their mounting surface, and vibration-resistant closure. They may be used where fastener components may not extend into the fastened equipment.

Materials and construction throughout the DZUS Toggle Latch line are adequate for rough outdoor use. For example, handles are riveted to their base for durability and smooth pivoting. Wire links are spring-temper stainless

steel, with ends under the handle flattened for secure retention (except TL-400).

**NOTE** —The selection and installation planning of fasteners can influence the security of the fastened parts. Dzus product information and support service is intended for use only by persons with mechanical engineering qualifications sufficient to manage the responsibilities of:

1. Analyzing fastener performance in relation to the service to be met, and
2. Planning appropriate fastening locations and installations.

TL800 Series offers a versatile range of medium size toggle latches built for rough outdoor use. Any combination of latch and wire link in the series may be specified, and with separately ordered strikes, a custom latch is readily available.

Latches and strikes are offered in yellow zinc plated steel or all-stainless steel. Wire links and the optional secondary lock catch for TL800 are always stainless steel. Handles are riveted to their base and link ends are staked inside the handle.

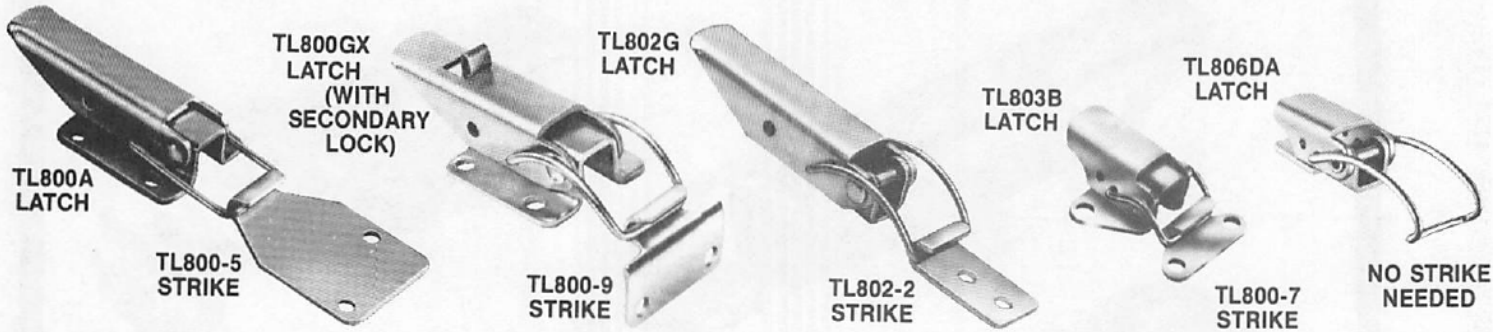

**LATCHES**

Latches are ordered as an assembly including the wire link. To specify a latch assembly, add the link letter (s) to the latch part number (Ex: TL 803 DA). Basic part numbers call out steel handles

and bases, zinc plated with yellow chromate finish. To specify an all-stainless assembly, add **SS** to the part number.

**TL800**  
**SPECIFICATIONS**  
 Strength:  
 Ultimate 700 lb.  
 Working 100 lb.  
 Pull-up ability: .6"  
 Mounting holes will accept .156" dia. rivets or #6 round head screws.  
 Material: Steel, zinc plated with yellow chromate finish, per QQ-Z-325C, Type II, Class 2, or all stainless steel 300 series. (Add SS to part number). Secondary lock catch is stainless steel.

**TL802**  
**SPECIFICATIONS**  
 Strength:  
 Ultimate 700 lb.  
 Working 100 lb.  
 Pull-up ability: .6"  
 Mounting Holes will accept .156" dia. rivets or #6 round head screws.  
 Materials: Steel, zinc plated with yellow chromate finish, per QQ-Z-325C, Type II, Class 2, or all stainless steel 300 series (Add SS to part number).

**TL803**  
**SPECIFICATIONS**  
 Strength:  
 Ultimate 220 lb.  
 Working 45 lb.  
 Pull-up ability: .2"  
 Mounting holes will accept .156" dia. rivets or #6 round head screws.  
 Materials: Steel, zinc plated with yellow chromate finish, per QQ-Z-325C, Type II, Class 2, or all stainless steel 300 series (Add SS to part number).

**TL806**  
**SPECIFICATIONS**  
 Strength:  
 Ultimate 220 lb.  
 Working 45 lb.  
 Pull-up ability: .2"  
 Mounting Holes will accept .156" dia. rivets or #6 round head screws.  
 Material: Steel, zinc plated with yellow chromate finish, per QQ-Z-325C, Type II, Class 2, or all stainless steel 300 series (Add SS to part number).

# TL800 SERIES



## WIRE LINKS

Links are all stainless steel, 17-7 PH spring temper, bare finish. The latch and link are ordered as an assembly. Link ends under the handle are flattened.

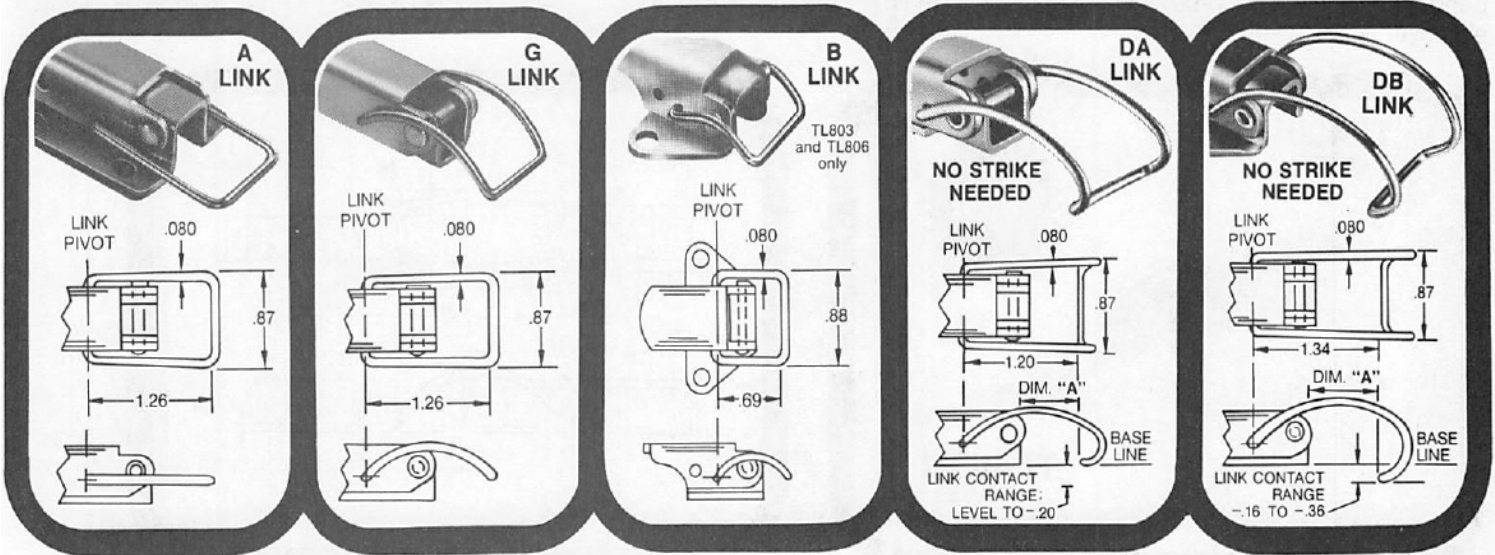

## STRIKES

Any TL800 series strike may be used with any latch. Zinc plate with yellow chromate or stainless

steel (add **SS** to part number). Material and finish specs same as latches.

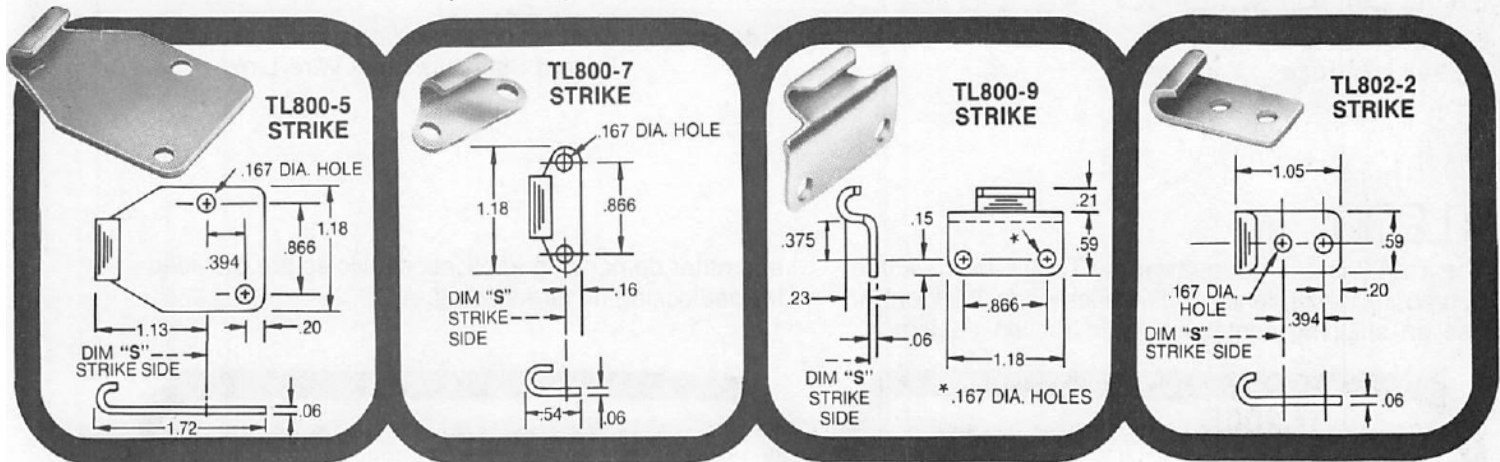

## SPACING FROM LATCH TO LINK CONTACT

The approximate spacing between each latch/link assembly and each strike is shown as dimension **S**. The approximate spacing between latches with hooked links (types **DA**

and **DB**) and the point of link contact is shown as dimension **A**. Precise spacing for optimum clamping force should be determined by trial.

LATCHES WITH STRIKES							
DIMENSIONS S, CLOSED POSITION							
STRIKE	TL800A	TL800G	TL802A	TL802G	TL803A OR TL806A	TL803B OR TL806B	TL803G OR TL806G
TL800-5	1.60	1.65	1.64	1.69	1.87	1.34	1.93
TL800-7	.85	.90	.89	.95	1.12	.59	1.18
TL800-9	.76	.82	.80	.86	1.04	.51	1.10
TL802-2					.20	.67	

LATCHES WITH NO-STRIKE LINKS		
DIMENSION A CLOSED POSITION		
LATCH	DA LINK	DB LINK
TL800	.57	.71
TL802	.61	.75
TL803	.85	.98



Get quote >>

Angic Global Solutions

1-888-872-0690

<https://www.AngicGlobal.com> Sales@AngicGlobal.com

## TL400

The TL400 is a miniature Toggle Latch for use on narrow banding or in limited space. It is suitable as a general-purpose, light duty latch.

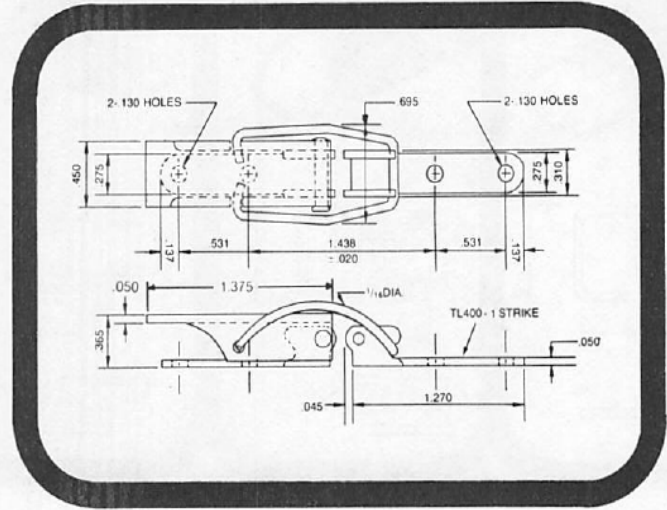

## SPECIFICATIONS

**Locked Tension** 30 lb  
**Pull-up distance** .7 inches

**Material** Cold rolled steel, zinc plated  
Except Stainless Steel Wire Link

## TL200

The TL200 is a large, heavy-duty Toggle Latch with a curved link for resilience under shock loads. It is ideal for use on shipping containers, construction equipment,

and other demanding applications. Holes are provided for padlocking or wire sealing.

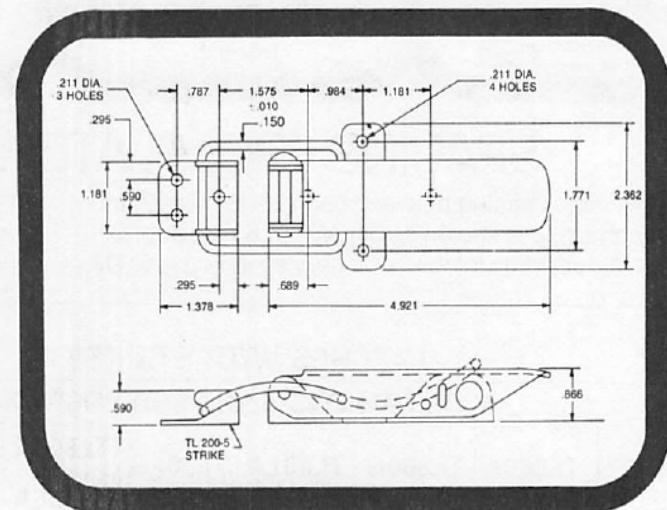

## SPECIFICATIONS

**Strength** Ultimate — 1500 lb

**Material** Cold rolled steel, zinc plated, with yellow chrome finish

# TL300 SERIES

## TL 300

The DZUS TL300A is the first in a new series of rugged adjustable-grip toggle latches. Its grip length and locking tension can easily be changed at any time. In locked position the adjustable draw bar and the strike are con-

cealed under the handle. This presents a neat, low-profile appearance, while minimizing the risk of snagging clothing and of impact damage to the latch.

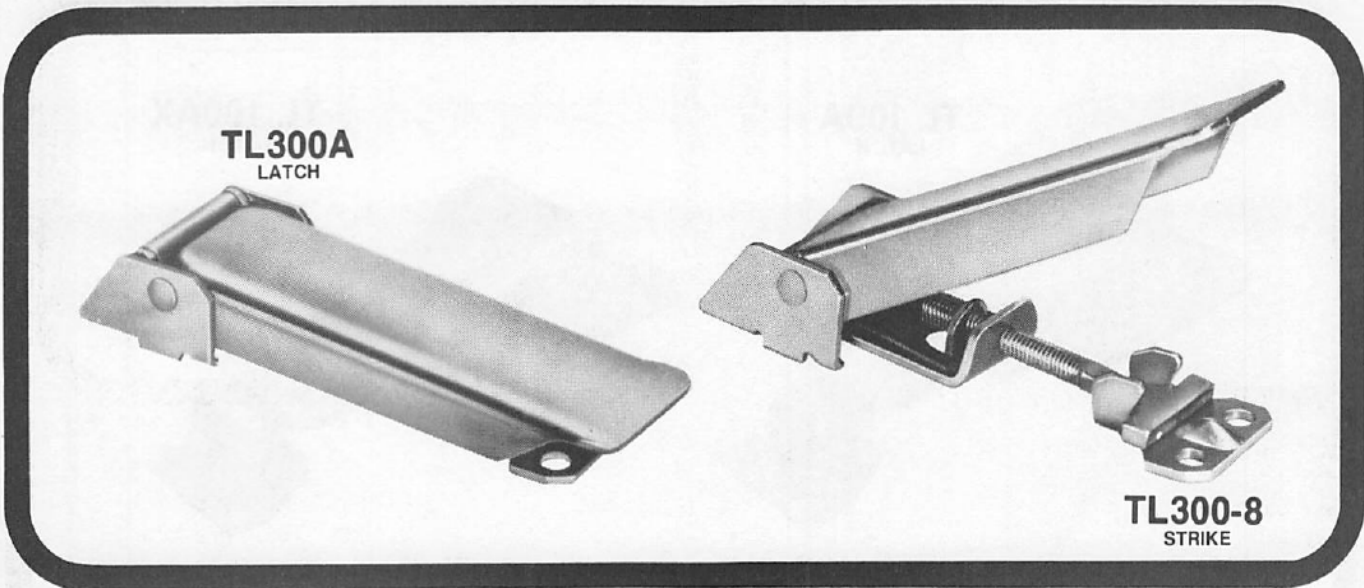

### Specifications

**STRENGTH** Ultimate 800 lb. (See Caution)  
 Working 600 lb.  
**ADJUSTMENT** .625"

**PULL-UP DISTANCE** .200"

**MATERIAL** Cold rolled steel, zinc plated, with yellow chromate finish.

**ALSO AVAILABLE IN STAINLESS STEEL**  
 300 Series. Add "SS" at end of part number

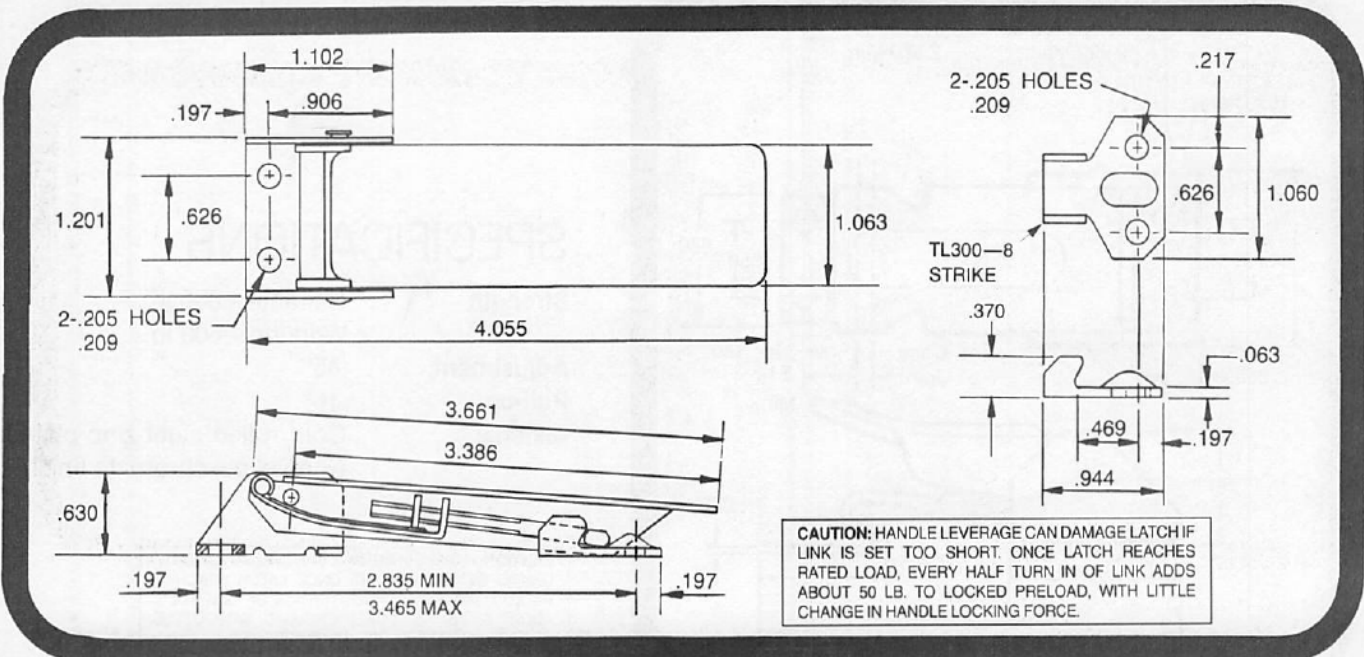

**CAUTION:** HANDLE LEVERAGE CAN DAMAGE LATCH IF LINK IS SET TOO SHORT. ONCE LATCH REACHES RATED LOAD, EVERY HALF TURN IN OF LINK ADDS ABOUT 50 LB. TO LOCKED PRELOAD, WITH LITTLE CHANGE IN HANDLE LOCKING FORCE.

**TL100 SERIES**

**TL 100**

The TL 100 Series of adjustable-grip toggle latches continues in popularity because of its short overall length, and the optional secondary lock on the TL 100 AX. The

secondary lock is extremely rugged, and must be manually operated before the draw hook can be disengaged from the strike. TL 100 Series latches use strike TL 100-5.

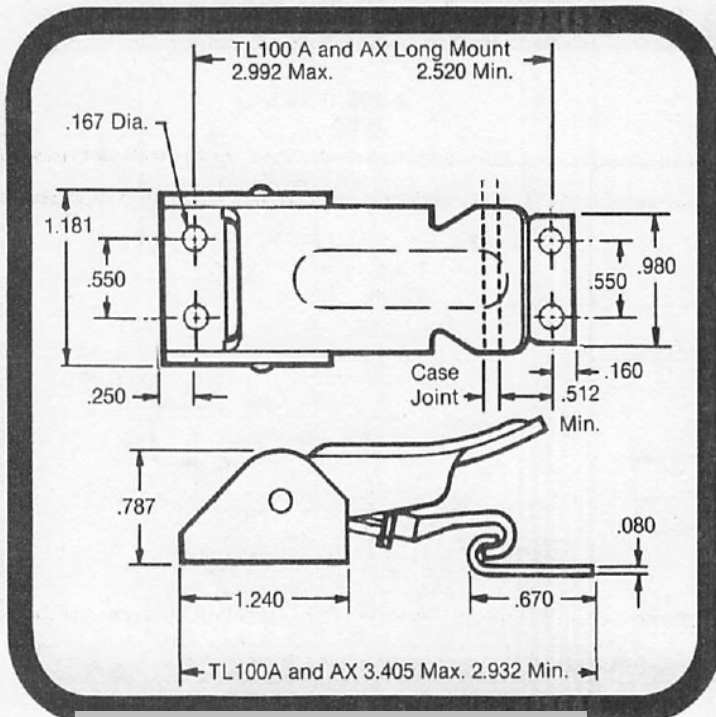
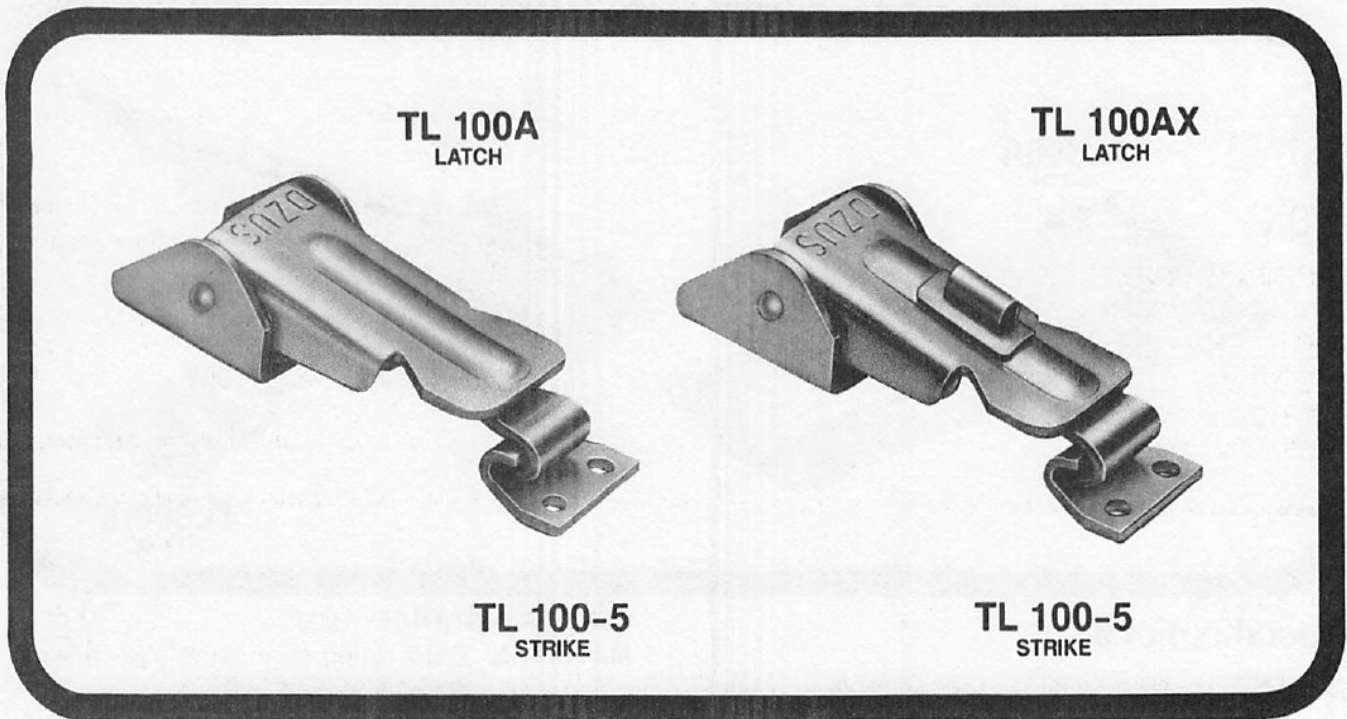

**SPECIFICATIONS**

<b>Strength</b>	Ultimate—800 lb. Working—600 lb.
<b>Adjustment</b>	.45"
<b>Pull-up</b>	.16"
<b>Material</b>	Cold rolled steel zinc plated, with yellow chromate finish.

**CAUTION:** HANDLE LEVERAGE CAN DAMAGE LATCH IF LINK IS SET TOO SHORT. ONCE LATCH REACHES RATED LOAD, EVERY HALF TURN IN OF LINK ADDS ABOUT 50 LB. TO LOCKED PRELOAD, WITH LITTLE CHANGE IN HANDLE LOCKING FORCE.

# TL110 SERIES

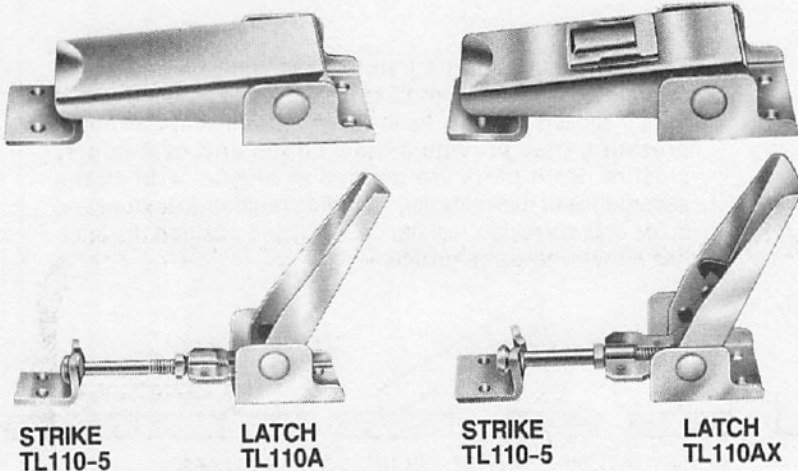

### TL110 series compact toggle latches feature:

- Adjustable grip
- Clean, enclosed styling
- Optional secondary lock
- Optional stainless steel

The optional secondary lock increases latched vibration security, and reduces the possibility of accidental release. Its spring return mechanism is positive and rugged, with a convenient, low-profile slide button.

### SPECIFICATIONS

Overall length, including -5 strike: min. 2.5", max. 2.9"

Overall width: .93"

Working tension: 270 lb. ft.

Ultimate tension: 326 lb. ft.

Adjustment: .31"

Pull-up: .31"

### MATERIALS AND FINISHES

Add the following suffixes to the basic part number to call out the desired material and finish:

Material/Finish	Use Suffix	Example
Steel, zinc plate, yellow chromate	none	TL110A
Stainless steel, no finish	-1	TL110AX-1

### INSTALLATION DATA

Latches and strike may be fitted with either 2.5mm dia round head rivets, #3 Unified round head screws, or #3 round head woodscrews. Fixing holes in latch and strike are 2.60mm dia.

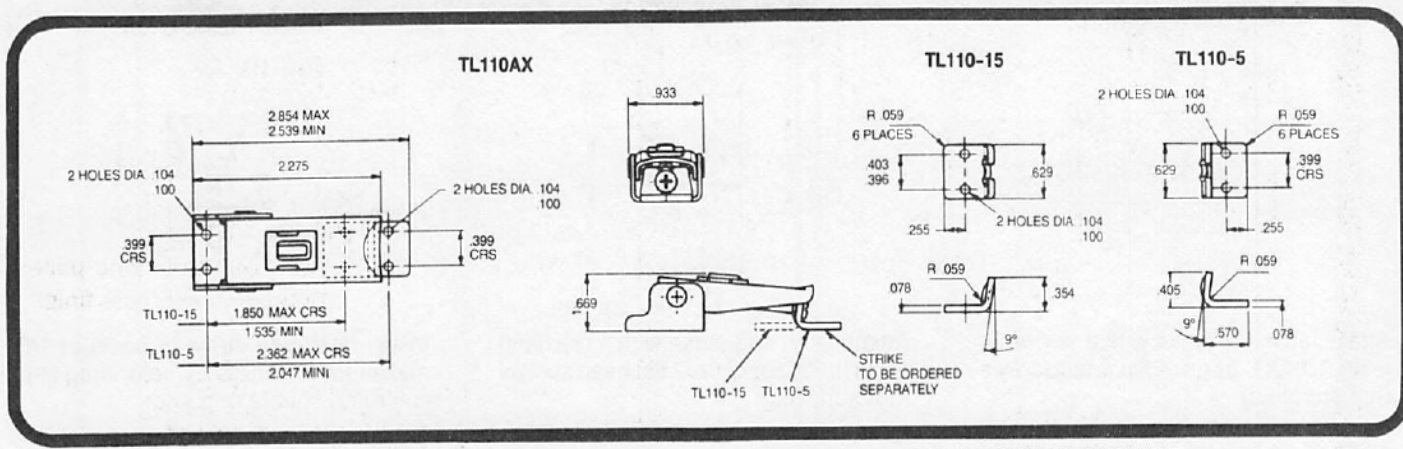
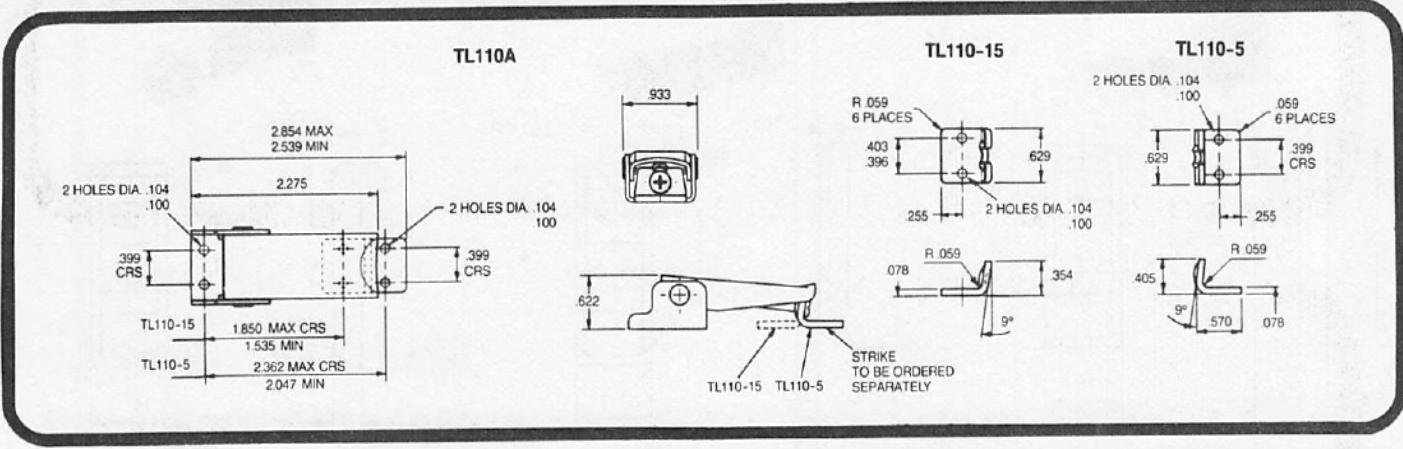

**CAUTION:** HANDLE LEVERAGE CAN DAMAGE LATCH IF LINK IS SET TOO SHORT. ONCE LATCH REACHES RATED LOAD, EVERY HALF TURN IN OF LINK ADDS ABOUT 35 LB. TO LOCKED PRELOAD, WITH LITTLE CHANGE IN HANDLE LOCKING FORCE.



Get quote >>

Angic Global Solutions

1-888-872-0690

<https://www.AngicGlobal.com> Sales@AngicGlobal.com

# DZUS

## FOLDING PLASTIC TOGGLE LATCH 411 SERIES

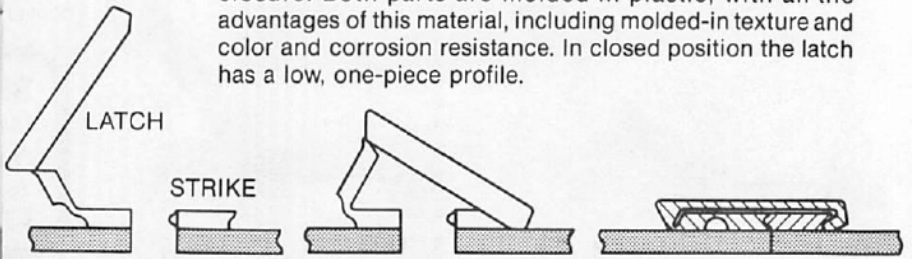
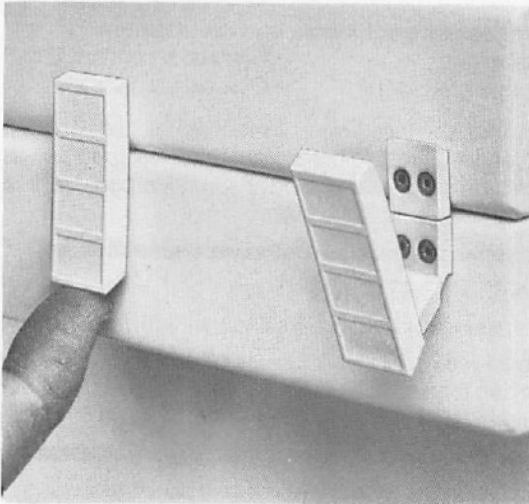

The Series 411 Toggle Latches consist of a one-piece segmented latch body and a strike that couples to the body's base in closed position. As the segments fold flat with finger pressure, they provide a draw action and over-center closure. Both parts are molded in plastic, with all the advantages of this material, including molded-in texture and color and corrosion resistance. In closed position the latch has a low, one-piece profile.

NOTE: LATCHES ARE SUPPLIED WITH STRIKES

**2 HOLE MOUNTING**  
LATCH AND STRIKE ASSEMBLY  
411-100-001 White  
411-100-010 Black

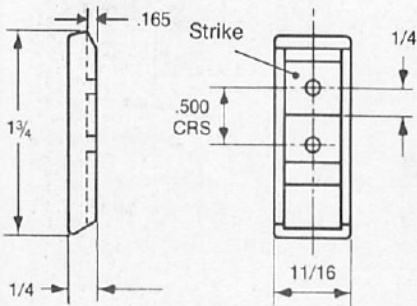
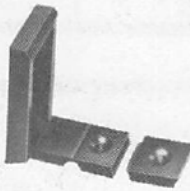

**PANEL PREPARATION**

2 Holes .128 Dia.

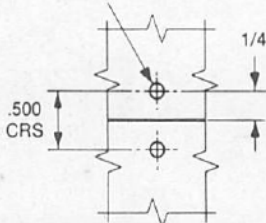

Attach latch and strike with 2 csk. head rivets 1/8 Dia. or no. 4 flat head screws (not supplied).

**4 HOLE MOUNTING**  
LATCH AND STRIKE ASSEMBLY  
411-200-001 White  
411-200-010 Black

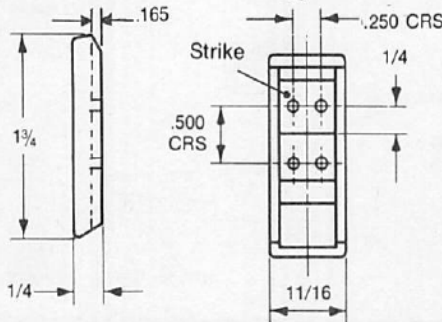
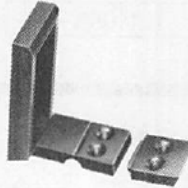

**PANEL PREPARATION**

4 Holes .098 Dia.

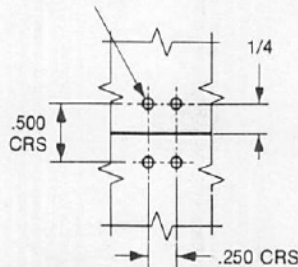

Attach latch and strike with 4 csk head rivets 3/32 Dia. or no. 2 flat head screws (not supplied).

**HEAT SWAGED PEG MOUNTING**  
LATCH AND STRIKE ASSEMBLY  
411-300-001 White  
411-300-010 Black

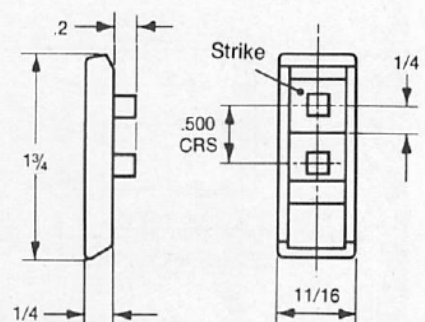
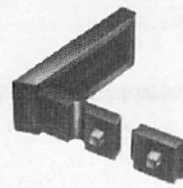

**PANEL PREPARATION**

2 Holes .187 Sq.

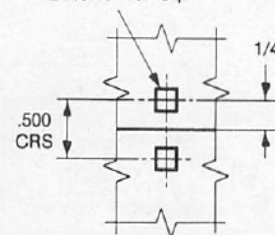

Install latch and strike in panel of 1/8 maximum thickness by deforming and enlarging square peg ends.

## SPECIFICATIONS

**Strength** Ultimate — 56 lb.

**Material** All parts: Polypropylene, black or white



## PANEL LATCHES

*Consider performance  
and convenience...  
because they'll be used*



ACCESS FASTENERS FOR PANELS,  
COVERS, AND DETACHABLE PARTS.

DZUS FASTENER CO. INC.  
West Islip, NY 11795 • 516-669-6000



## QUICK-ACTING FASTENERS

*Quick-installing, too.  
These snap in from above!*

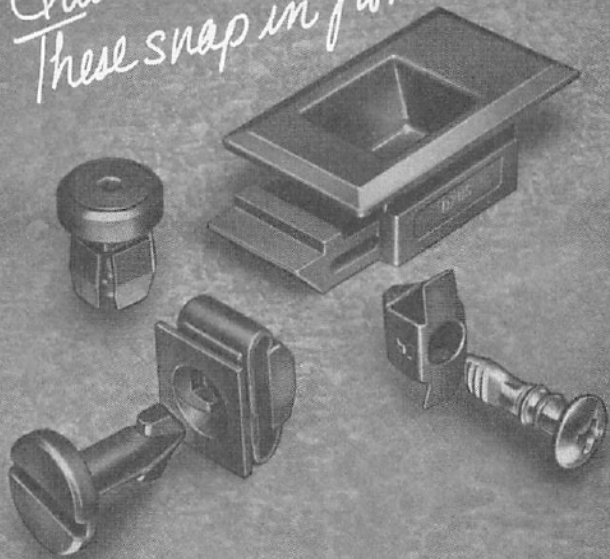

ACCESS FASTENERS FOR PANELS,  
COVERS, AND DETACHABLE PARTS.

DZUS FASTENER CO. INC.  
West Islip, NY • 516-669-6000



## QUICK-ACTING FASTENERS

*Dzus makes it easy  
to match the fastener  
to the job.*

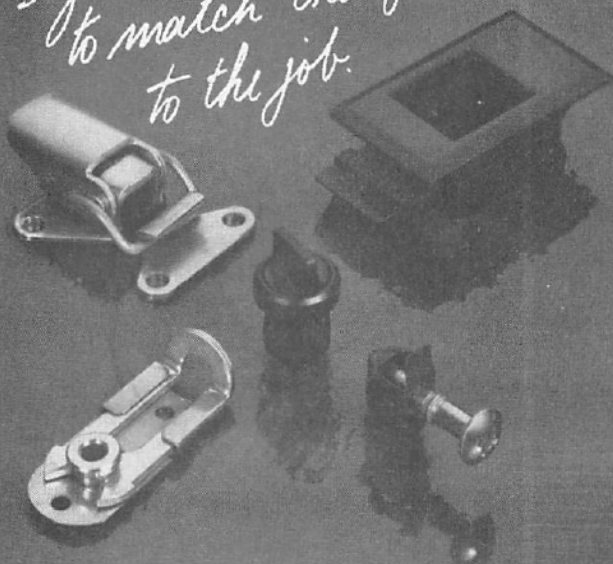

ACCESS FASTENERS FOR PANELS,  
COVERS, AND DETACHABLE PARTS.

DZUS FASTENER CO. INC.  
West Islip, NY 11795 • 516-669-6000



## 1/4-TURN FASTENERS

*Chances are we have a standard  
one for your special needs!*



ACCESS FASTENERS FOR PANELS,  
COVERS, AND DETACHABLE PARTS.

DZUS FASTENER CO. INC.  
West Islip, NY 11795 • 516-669-6000



Get quote >>

Angic Global Solutions

1-888-872-0690

<https://www.AngicGlobal.com> [Sales@AngicGlobal.com](mailto:Sales@AngicGlobal.com)

# PAWL LATCHES

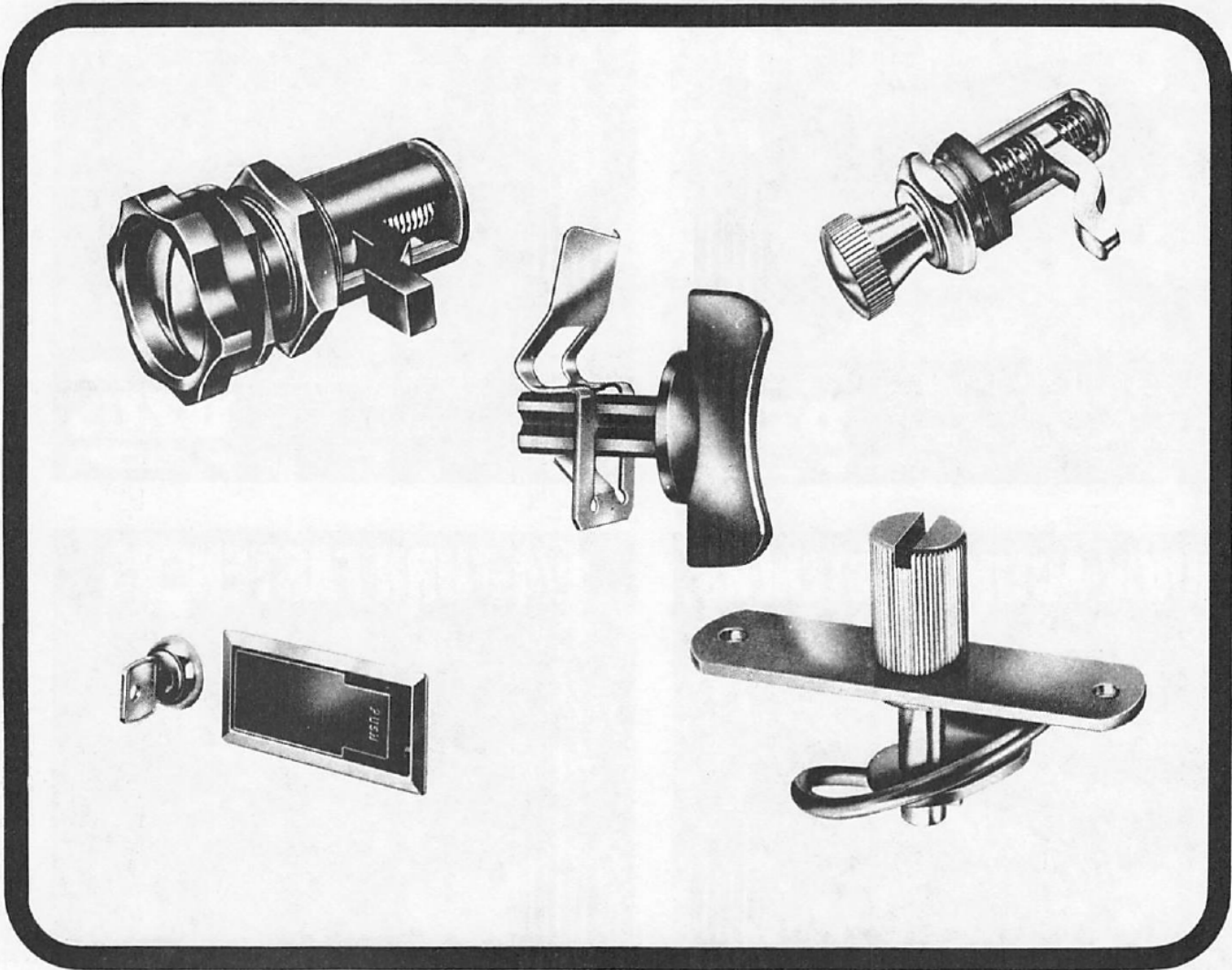

DZUS Pawl Latches offer ¼ turn operation with locking under tension, over a wide range of material thickness. Their variable grip length can accommodate wide thickness and misalignment tolerances.

**NOTE** —The selection and installation planning of fasteners can influence the security of the fastened parts. Dzus product information and support service is intended for use only by persons with mechanical engineering qualifications sufficient to manage the responsibilities of:

1. Analyzing fastener performance in relation to the service to be met, and
2. Planning appropriate fastening locations and installations.

# PAWL LATCH SERIES DP-106

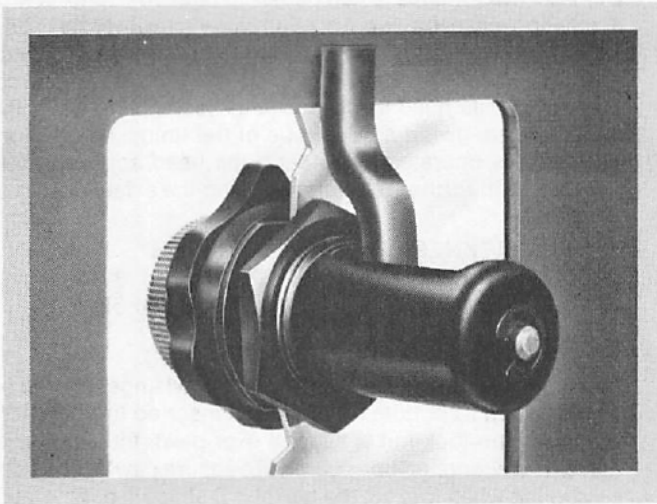

**PANEL THICKNESS RANGE:** .048 min. to .128 max.

**GRIP RANGE:** Short Grip (pawl curved towards panel)  
.12 min. to .82 max.

Long Grip (pawl curved away from panel)  
.74 min. to 1.44 max.

**MATERIALS:** Center Spindle, Pawl, Locknut: Steel, Zinc plated, yellow chromate finish.  
Barrel: Die cast zinc, black finish.  
Indicator Sleeve and outer ring: Black thermoplastic.  
Center Head: Steel (knurled head is zinc) finished as specified.

## 1/4 TURN LATCHING, ISOLATED ADJUSTMENT

DP 106 Pawl Latches are ideal fasteners for gasketed doors and access panels subject to wide thickness or misalignment tolerances. Grip length is variable from 1/8" to 17/16", and is set by rotating the center spindle until satisfactory locking tension is felt. Then the latch can be opened and locked with 1/4 turn of the outer ring, while the pre-set grip length is maintained. A pointer on the outer ring shows pawl position.

**SLOTTED HEAD** grip length set with screwdriver or coin.

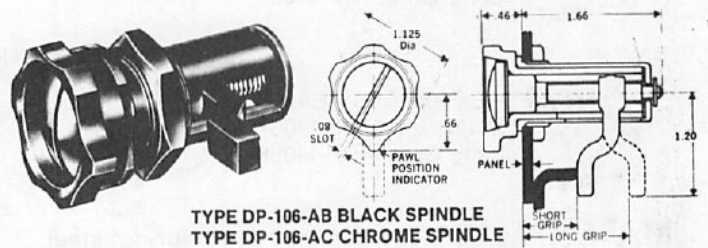

**SOCKET HEAD** grip length set with hexagonal key.

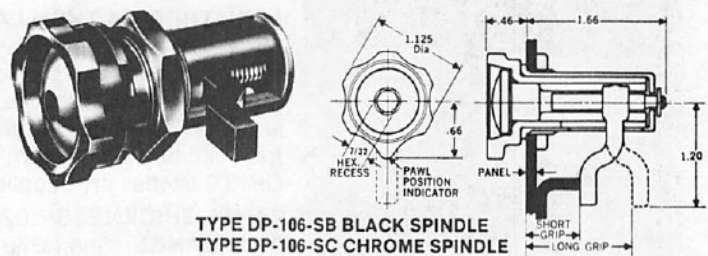

**KNURLED HEAD** grip length set manually.

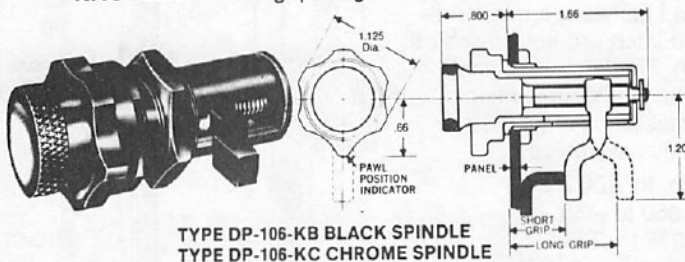

## INSTALLATION

1. Thread locknut (5) on barrel and tighten securely to maintain barrel in correct position.
2. Partly enter indicator sleeve (3) into barrel, aligning sleeve slot with barrel opening.
3. Slide head of pawl (4) into sleeve slot, with curve in required position, and push sleeve fully home.
4. Insert spindle (2) into sleeve and thread into pawl head. Push spindle nose through base of barrel and secure with retaining ring (6).
5. Adjust spindle to attain desired locking tension.

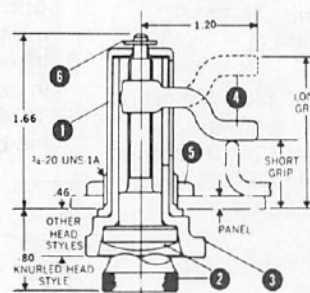

## PANEL PREPARATION

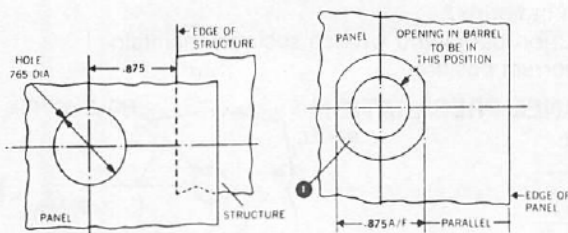

Series DP-106 Pawl Latches are shipped unassembled, allowing pawl to be placed in either short or long grip position. Assembly take



Get quote >>

Angic Global Solutions

1-888-872-0690

81

<https://www.AngicGlobal.com> [Sales@AngicGlobal.com](mailto:Sales@AngicGlobal.com)

**FAST**

# DZUS

**FASTENING**

## PAWL LATCH SERIES DP-140 SERIES DP-109

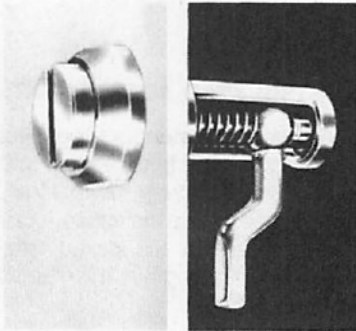

DP-140 Pawl Latches fasten panels to backup supports with a rotating pawl having an adjustable grip length. Their variable pawl position allows them to accept wide thickness variation, to compress gaskets, and to adjust clamping force. The low profile head ejects above its escutcheon when the latch is open, giving a visual cue of the unlocked position. The latch is operated by rotating the head approximately 1/4-turn, with further rotation changing the axial position of the pawl.

**PANEL THICKNESS RANGE:** .048 to .128  
**LATCH GRIP RANGE, SHORT GRIP:** .32 to .91  
**LATCH GRIP RANGE, LONG GRIP:** .92 to 1.50

### INSTALLATION

The latch is supplied assembled. The pawl finger should be wound down to bottom of barrel and inserted through hole in panel. The lock nut is slipped over pawl, threaded onto barrel and wrenched up securely. To ensure pawl is correctly positioned when locked, the barrel is D shaped, but the latch can be fitted to round hole if correctly aligned.



**SLOTTED HEAD:**

Short Grip: DP-140S  
 Long Grip: DP-140L

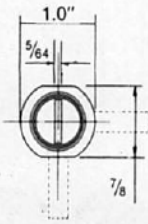

**HEX RECESS HEAD**

Short Grip: DP-140SH  
 Long Grip: DP-140LH

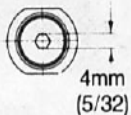

**MATERIALS:** Head/spindle, pawl, spring: steel, clear chromate finish.  
 Barrel/escutcheon: diecast zinc, clear chromate finish.

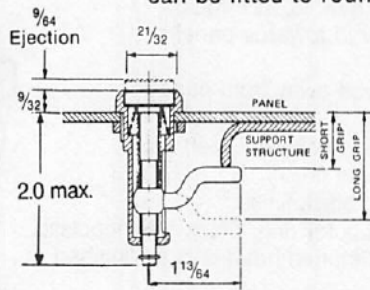

### PANEL PREPARATION

RELATIONSHIP BETWEEN PANEL HOLE AND PAWL FINGER VIEWED FROM TOP

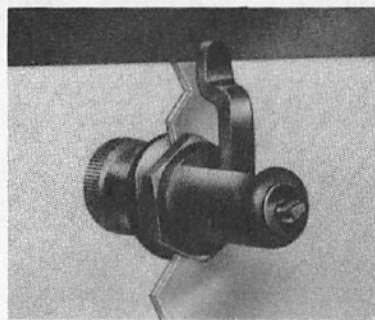
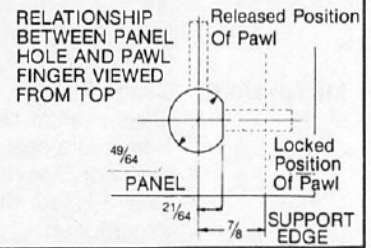

### MINIATURE 1/4 TURN LATCHING

Series DP-109 Adjustable Pawl Latches are miniature-size. Heads are low-profile and latch projection behind the panel is less than one inch. The latch is opened and locked in about 1/4 turn. When locking, rotation of the head beyond 1/4 turn increases locking tension. DP-109 latches are supplied fully assembled.

**PANEL THICKNESS:** .025 min. to .130 max.  
**GRIP RANGE:** Short Grip — .050 to .450  
 Long Grip — .375 to .750

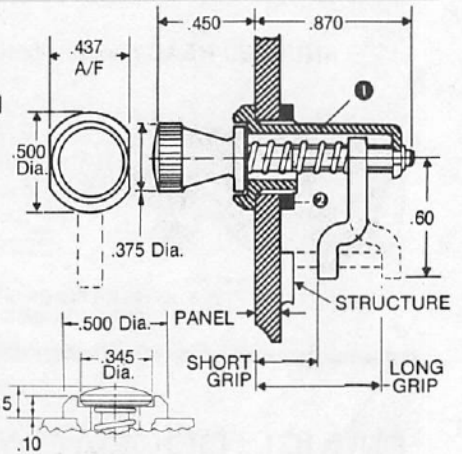

### INSTALLATION

1. Prepare panel as shown in fig. 1
2. Unscrew pawl to its maximum grip position and ensure that pawl is in center of the barrel opening, remove locknut (2).
3. Insert barrel (1) into hole and ensure that flats and barrel are in position shown in figure 2.
4. Thread locknut (2) on barrel and wrench securely maintaining barrel in the correct position.

### PANEL PREPARATION

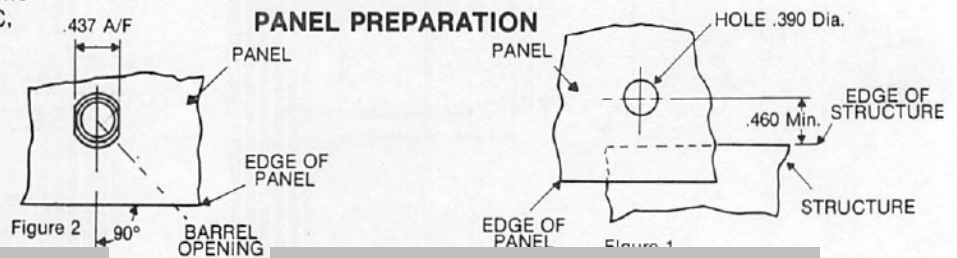

Knurled head zinc plated short grip DP-109-S. Long grip DP-109-L. Knurled head chrome plated, short grip DP-109-SC, long grip DP-109-LC.

Slotted head zinc plated short grip DP-109-SA, long grip DP-109-LA. Slotted head chrome plated, short grip DP-109-SAC, long grip DP-109-LAC.

### MATERIALS:

**Spindle:** Steel, finish as specified.  
**Pawl, Spring, Locknut:** Steel, bright zinc plated.  
**Barrel:** Die cast zinc.



Get quote >>>

# SELF ADJUSTING SPRING PAWL LATCH SERIES DP170, DP175

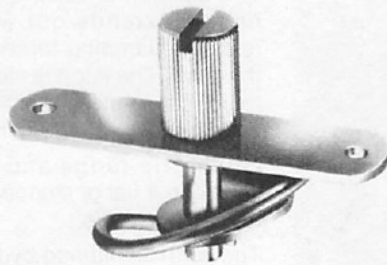
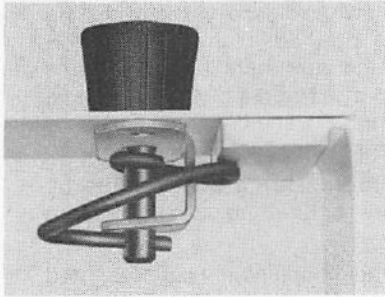

The DP170 and the larger DP175 Series Pawl Latches use a helical spring pawl which varies its grip length with rotation and is capable of latching a wide range of support thickness. The sloped pawl design also allows the operator to adjust the applied clamping force.

Four head styles are offered in each size, and an all-stainless knurled head latch is available in the larger size.

### MATERIAL AND FINISH, DP170, DP175:

Latch Heads: As tabulated

Latch Body: Steel, zinc plate, yellow chromate

Spring Pawl: Stainless steel DP170; Zinc plated steel DP175  
(Latch DP175KS is all stainless steel)

### DP170 KNURLED HEAD (K)

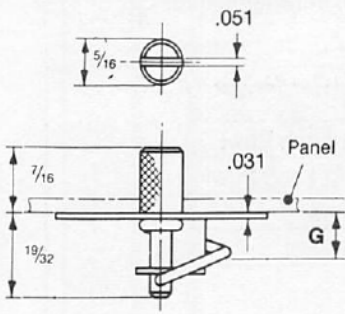

Part No.	Head Finish
DP170KY	Zinc Plate, Yellow Chromate
DP170KC	Chrome Plate

Grip Range G: .039-.250

### DP170 PAN HEAD

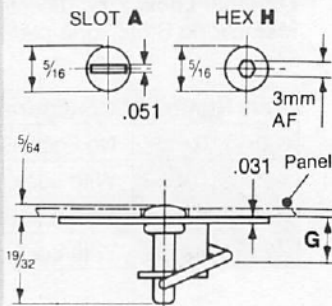

Part No.	Head	Head Finish*
DP170AY	Slot	Zinc, Yellow
DP170AB	Slot	Zinc, Black
DP170HY	Hex	Zinc, Yellow
DP170HB	Hex	Zinc, Black

\*All with chromate surface

Grip Range G: .039-.250

### DP170 PLASTIC KNOB HEAD (P)

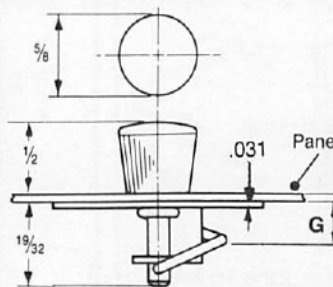

Part No.	Head Material
DP170P	Black Thermoplastic

Knob is supplied unattached and is pressed onto head after installing latch

Max. panel w/knob: .177

Grip Range G: .039-.250

### DP170 UNDER-PANEL DIMENSIONS

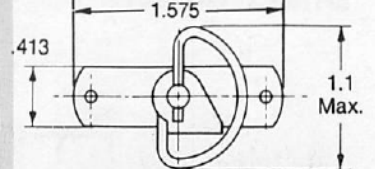

### PANEL PREPARATION

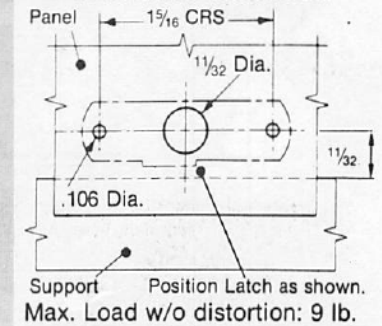

### DP175 KNURLED HEAD (K)

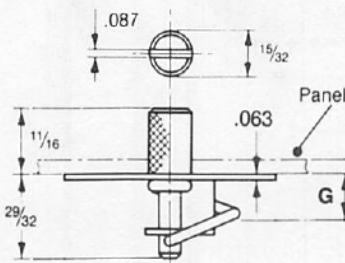

Part No.	Head Finish
DP175KY	Zinc Plate, with Yellow Chromate
DP175KC	Chrome Plate

Grip Range G: .078-.438

### DP175 PAN HEAD

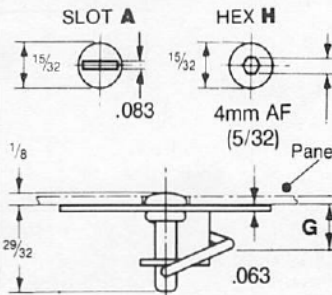

Part No.	Head	Head Finish*
DP175AY	Slot	Zinc, Yellow
DP175AB	Slot	Zinc, Black
DP175HY	Hex	Zinc, Yellow
DP175HB	Hex	Zinc, Black

\*All with chromate surface

Grip Range G: .078-.438

### DP175 PLASTIC KNOB HEAD (P)

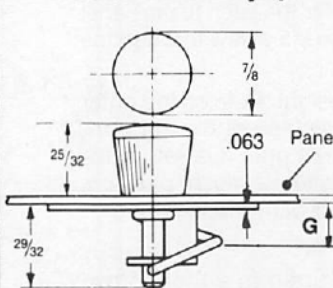

Part No.	Head Material
DP175P	Black Thermoplastic

Knob is supplied unattached and is pressed onto head after installing latch

Max. Panel w/knob: .250

Grip Range G: .078-.438

### DP175 UNDER-PANEL DIMENSIONS

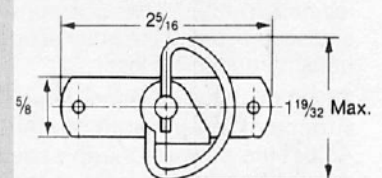

### PANEL PREPARATION

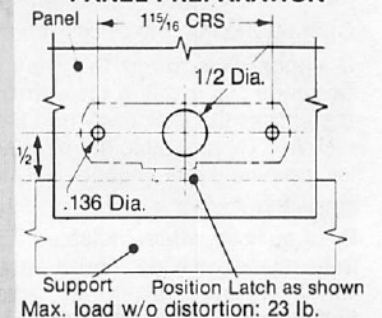

Get quote >>

Angic Global Solutions

1-888-872-0690

<https://www.AngicGlobal.com> [Sales@AngicGlobal.com](mailto:Sales@AngicGlobal.com)

## LIFT AND TWIST FLUSH PAWL LATCH SERIES 425

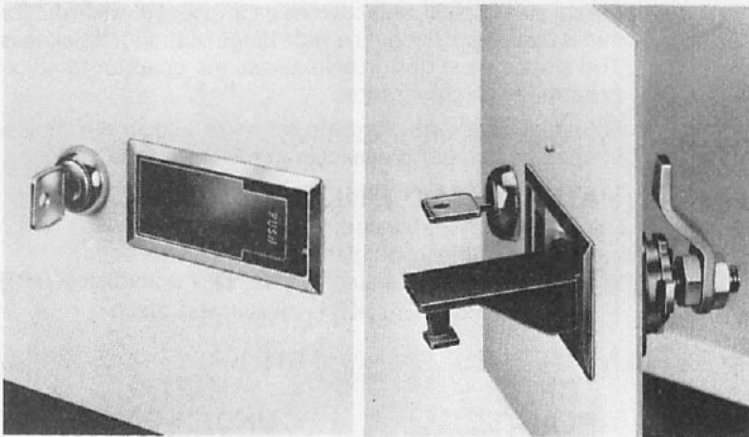

This satin black latch is flush when closed, yet its operating handle extends out when pushed. Handle extension releases clamping force on the pawl; handle rotation turns the pawl. The latch is closed by a reverse turn of the handle to point the pawl under the support, and clamping tension is again applied as the handle is pushed into its recess.

Latch grip range and clamping force are variable by selecting a flat or stepped pawl and setting pawl position on the latch spindle.

The latch is retained by a bracket behind the panel secured by a screw, both provided. An optional keylock is offered.

### DIMENSIONS

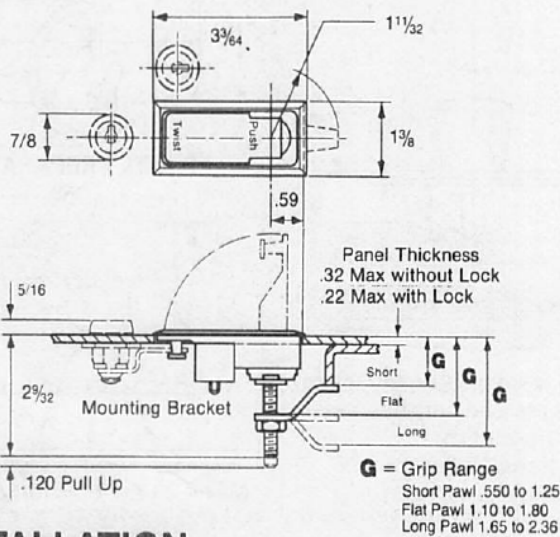

### INSTALLATION

Prepare a rectangular hole as shown, either at right angles to, or parallel with, the door edge. If required the lock may be located in either of two positions. Offer the latch to the panel and secure, using the bracket and the M5 screw through the housing under the lever.

To set the pawl, measure the grip height 'G' from the outer surface of the panel to the inner surface of the support. Adjust the pawl on the threaded shaft until it is set to this dimension with the lever in the closed, i.e. flush, position. Lock the pawl in the desired position with the lock nut.

Operate the latch to check the setting.

If a lock is required this may be fitted in either of two positions. To install a lock, first remove the locking pawl, then insert the lock body into the panel and retain with the lock nut. Re-assemble the pawl and check for correct angular movement and engagement with the lever locking peg.

#### Operation

Push on lever where indicated. The lever will tilt, allowing it to be raised to a vertical position releasing the pawl grip load. Twist the lever through 90°, disengaging the pawl from behind the support. The panel is then free to open.

### MATERIAL AND FINISH

**Recessed Housing:** Zinc diecasting, black powder coated.

**Handle:** Black thermoplastic.

**Optional Lock:** Zinc diecasting, chrome plated.

**Metalwork:** Steel, zinc plated.

Part Number	Configuration
425-710-552	No Lock, Short/Long Pawl
425-810-552	With Lock, Short/Long Pawl
425-720-552	No Lock, Flat Pawl
425-820-552	With Lock, Flat Pawl

### PANEL PREPARATION

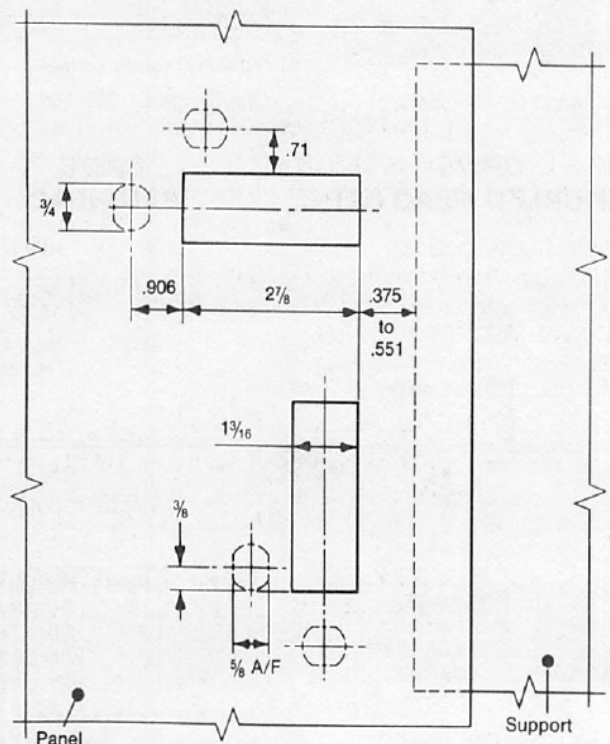

# PAWL LATCH MINI-LOW PROFILE FIXED GRIP SERIES 462

mm  
inch  
mm/inch

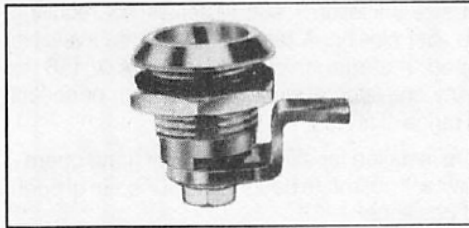

## PAWL LATCH ASSEMBLY

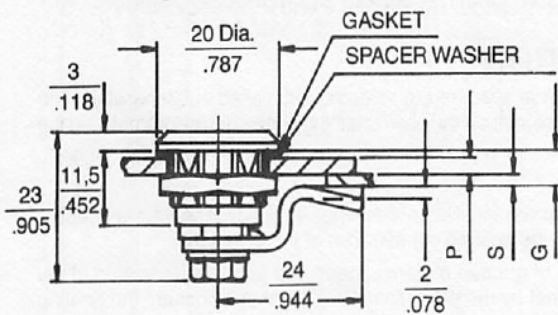

P - PANEL S - SUPPORT G - GRIP, 6,0 mm MAX.  
SPACER WASHER IS OPTIONAL .236

## PANEL HOLE DETAILS

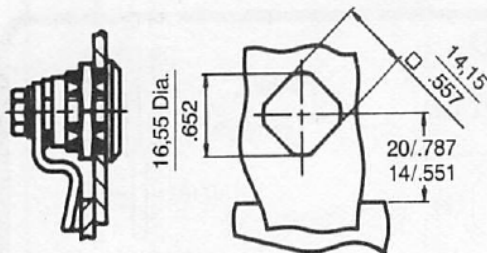

## TECHNICAL DATA

Maximum recommended operating torque 2,8 Nm/24 LB. IN.  
Ultimate clamp load (to produce permanent set in pawl) 60 N/14 LB.  
Panel Range (including seals/spacers) 5 mm max./.197  
(Note: Other pawls may be added to range)  
Maximum recommended tightening torques:-  
M16 (19 mm/.748 A/F) Lock Nut 7 Nm/60 LB. IN.  
M5 (8mm/.315 A/F) Retaining Screw 4 Nm/35 LB. IN.  
Units with full sealing are an option  
Operating temperature range -30°C/-22°F to 120°C/248°F

A more compact latch than Series 461 (Page 86), offering similar style with reduced dimensions.

A slotted head version is only available at present and other head styles may follow, together with other pawls.

U.S. APPROVED

## PAWL

Part Number 462 505 192

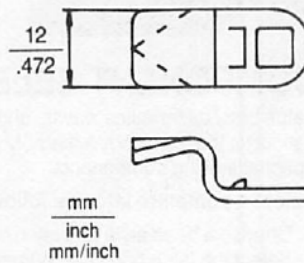

## BODY ASSEMBLY

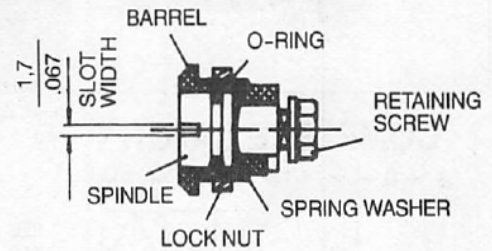

Part Number	Type of Seal
462-AAN-AOO-570	No Seals
462-ABN-AOO-570	O-Ring
462-ACN-AOO-570	O-Ring & Gasket

## HEAD STYLE



SLOT  
1.7 MM/.067  
CODE A

## MATERIALS AND FINISH

Barrel: Die Cast Zinc  
Spindle: Die Cast Zinc  
Pawl: Steel, Zinc Plate and Clear Passivation  
Nuts: Steel, Zinc Plate and Clear Passivation  
Sealing Washer: Neoprene black  
Finish Codes: See Page 87

## INSTALLATION PROCEDURE

Latches are normally ordered and dispatched as body sub-assemblies and separate pawls. This will allow the pawl to be fitted after the body is inserted into the panel. The installation procedure is as follows:

Fit Spacer Washer to body, if required. Fit Gasket to body, if required. Pass body through panel hole and check that the pawl stops are correctly aligned for LH or RH operation.

Lock the body into the panel using the Lock Nut, tightening to 7 Nm./60 LB. IN. Remove Pawl Retaining Screw and fit pawl to the spindle, check that the spindle head is correctly orientated. Replace Pawl Screw and tighten to 4 Nm/35 LB. IN. Tighten against the pawl, not the housing. Check the operation of the assembly, orientation of the spindle and movement of the pawl.

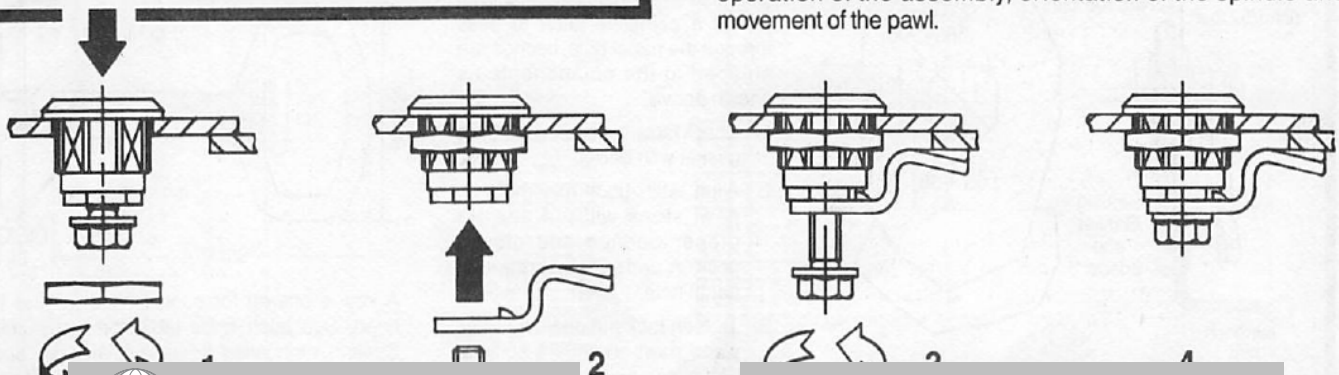

Get quote »

Angic Global Solutions

1-888-872-0690

<https://www.AngicGlobal.com> [Sales@AngicGlobal.com](mailto:Sales@AngicGlobal.com)

# FAST DZUS

FASTENING

# PAWL LATCH SOLID FIXED GRIP SERIES 461

mm  
inch  
mm/inch

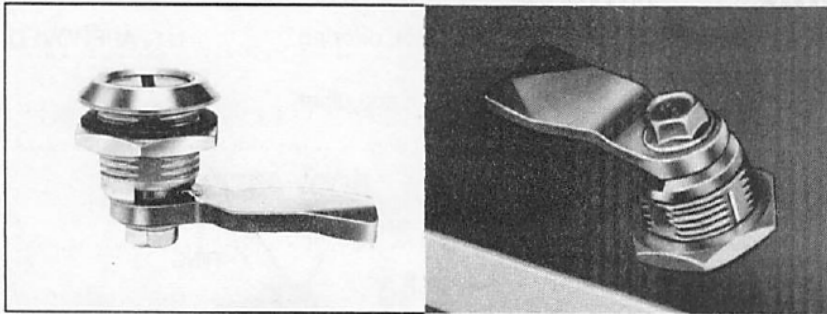

Series 461 latches provides a strong low-flexure grip, ideal for medium size enclosures with materials not requiring wide takeup after closing. A range of pawls are available to fit gripped material thickness from 4.0/.156 to 31.5/1.25. Any one latch assembly will take up or accept a thickness range of at least 1.5/.059.

They may be installed for either right or left hand operation. The pawl will not rotate beyond the 90° span of open and closed positions.

All Series 461 latches are offered in an optional sealed version, suitable for NEMA 4 and IP65 enclosures.

## COMPLETE LATCH

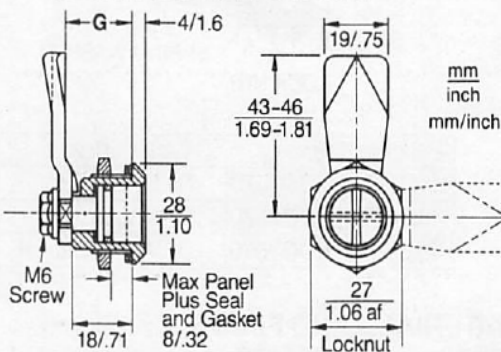

## COMPONENT SELECTION

Latch body assemblies, pawls, and optional spacers are selected and called out separately. The callout for the latch body assembly will also include the pawl retaining screw, barrel lock nut, and the optional sealing components.

Select a complete latch as follows:

1. Choose a head style and latch front face finish. Determine whether optional sealing is needed. Select the latch body part number for the desired combination of these features.
2. Determine which pawl fits your span of gripped material, measured from the underside of the barrel bezel to the material surface met by the pawl (Dim. G). This should include the sealing gasket thickness, if used.
3. Check latch operating torque and clamping load with a sample and test installation. The pawl selection table assumes rigid gripped materials, and material flexure under latch clamping may suggest a thinner-grip pawl or addition of an optional spacer.

## COMPONENTS AS SHIPPED

### LATCH BODY ASSEMBLY

#### NO SEALING

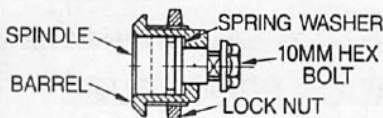

Select latch body assemblies by head style, front face finish, and sealing option, from latch body table.

#### MATERIALS:

**Barrel:** Die cast zinc.  
**Spindle:** Die cast zinc.  
**Lock Nut:** Steel.  
**Pawl Screw:** Steel.  
**Spring Washer:** Spring steel.

All steel parts are zinc plated with clear chromate finish.

#### SEALING OPTION

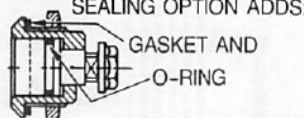

#### MATERIALS:

**Sealing Gasket:** Black neoprene rubber.  
**O-Ring:** Nitrile rubber.  
Sealing gasket dimensions are same as for spacer.

#### SPACER OPTION



461-105-040

#### MATERIALS:

Polyethylene, natural color.

### PAWL

mm/inch

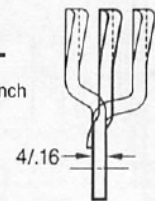

Select by grip span from pawl selection table.

#### MATERIALS:

Steel, zinc plate with clear chromate finish.

#### PERFORMANCE DATA:

Maximum recommended operating torque: 10Nm/88 lb. in.  
Ultimate clamp load (permanent set in pawl): 320N/72 lb.  
Operating temperature range: -30°C/-22°F to 120°C/ 248°F  
With sealing option, supports enclosures: IP65/NEMA 4

## INSTALLATION

Because some installations will not permit a complete latch to pass through the panel hole, latches are shipped in the components as shown above.

1. Check radial alignment of sealing gasket with barrel.
2. Align latch body assembly so pawl stops will put pawl in proper opened and closed position, and pass body through panel hole.
3. Tighten lock nut against panel, place pawl on square spindle, and attach pawl screw.

## OPERATING KEY

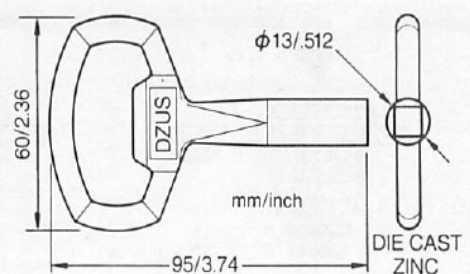

A key is offered for each limited access latch head. See latch body table for part numbers. Custom embossed logos available on special order.

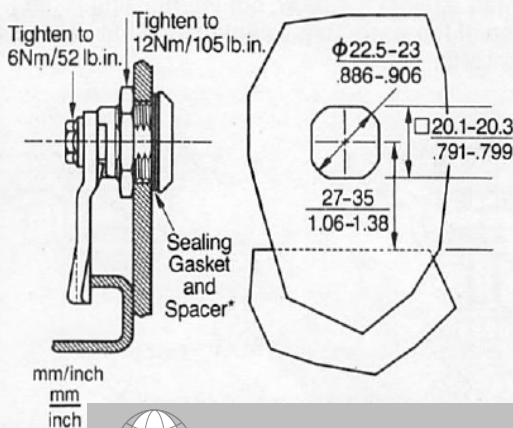

Get quote







Angic Global Solutions

1-888-872-0690

<https://www.AngicGlobal.com> [Sales@AngicGlobal.com](mailto:Sales@AngicGlobal.com)

mm  
 inch  
 mm/inch

**LATCH BODY SELECTION**

HEAD STYLE	SEALING OPTION	— LATCH FRONT FACE FINISHES—			KEY CALLOUT
		ZINC PLATE CLEAR CHROMATE	WHYKROM®	BLACK XYLAN®	
 <b>SLOT</b> 2.2mm	WITH SEALING	461ACN-A00-592	461ACN-A00-576	461ACN-A00-553	NONE
	NO SEALING	461AAN-A00-592	461AAN-A00-576	461AAN-A00-553	
 <b>SQUARE</b> 7mm	WITH SEALING	461ACN-C00-592	461ACN-C00-576	461ACN-C00-553	439-117-592
	NO SEALING	461AAN-C00-592	461AAN-C00-576	461AAN-C00-553	
 <b>SQUARE</b> 8mm	WITH SEALING	461ACN-D00-592	461ACN-D00-576	461ACN-D00-553	439-118-592
	NO SEALING	461AAN-D00-592	461AAN-D00-576	461AAN-D00-553	
 <b>TRIANGLE</b> 7mm	WITH SEALING	461ACN-E00-592	461ACN-E00-576	461ACN-E00-553	439-124-592
	NO SEALING	461AAN-E00-592	461AAN-E00-576	461AAN-E00-553	
 <b>TRIANGLE</b> 8mm	WITH SEALING	461ACN-F00-592	461ACN-F00-576	461ACN-F00-553	439-125-592
	NO SEALING	461AAN-F00-592	461AAN-F00-576	461AAN-F00-553	
 <b>STOP-SLOT</b> 3mm pin	WITH SEALING	461ACN-J00-592	461ACN-J00-576	461ACN-J00-553	439-133-592
	NO SEALING	461AAN-J00-592	461AAN-J00-576	461AAN-J00-553	
 <b>STOP-SLOT</b> 5mm pin	WITH SEALING	461ACN-P00-592	461ACN-P00-576	461ACN-P00-553	439-135-592
	NO SEALING	461AAN-P00-592	461AAN-P00-576	461AAN-P00-553	

XYLAN® IS A REGISTERED TRADEMARK OF WHITFORD CORPORATION  
 WHYKROM® IS A REGISTERED TRADEMARK OF WHYCO INCORPORATED.

**PAWL SELECTION**

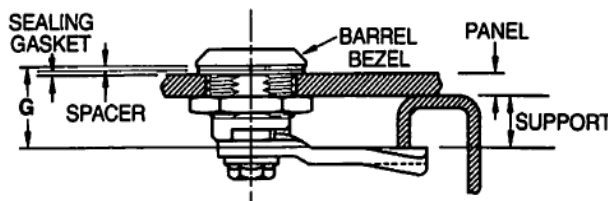

Dimension 'G' is the span of gripped material, assumed to be rigid, from the underside of the barrel bezel to the support surface met by the pawl.

A test installation may show that flexure of gripped material under latch clamping has expanded pawl grip range or reduced latch clamping force. The optional spacer, 1.0/.04 thick may be placed under the head to adjust for flexure and optimize latch operation.

G DIMENSION:		PAWL PART NUMBER	PAWL GRIP CODE
MIN.	MAX.		
47/16	59/23	461-504-192	04
61/24	73/31	461-506-192	06
87/32	99/39	461-508-192	08
107/40	119/47	461-510-192	10
127/48	139/55	461-512-192	12
147/56	159/63	461-514-192	14
167/64	179/71	461-516-192	16
187/72	199/79	461-518-192	18
207/80	219/87	461-520-192	20
227/88	239/95	461-522-192	22
247/96	259/103	461-524-192	24
267/104	279/111	461-526-192	26
287/112	299/119	461-528-192	28
307/120	319/127	461-530-192	30

**ASSEMBLED LATCHES**

Latch body assemblies with pawl attached are available on special order.

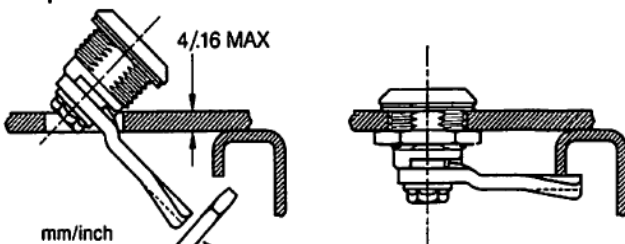

Some combinations of panel thickness and pawl grip will allow a latch body with attached pawl to pass through the panel hole. This reduces installation steps to attachment of the optional sealing gasket and/or spacer and threading on of the lock nut.

A body assembly with pawl attached is called out by modifying the latch body part number as follows:

1. Replace the 'N' in the second callout sequence with 'A'. This refers to attached pawls with a radial reach of 4.5/177 nom.
2. Replace the '00' in the third callout sequence with the grip code of the pawl to be attached.

Example: 461ACN-E00-592 and 461-518-192 components  
 become:  
 461ACA-518-592 body with pawl attached



Get quote >>

Angic Global Solutions 1-888-872-0690  
<https://www.AngicGlobal.com> Sales@AngicGlobal.com

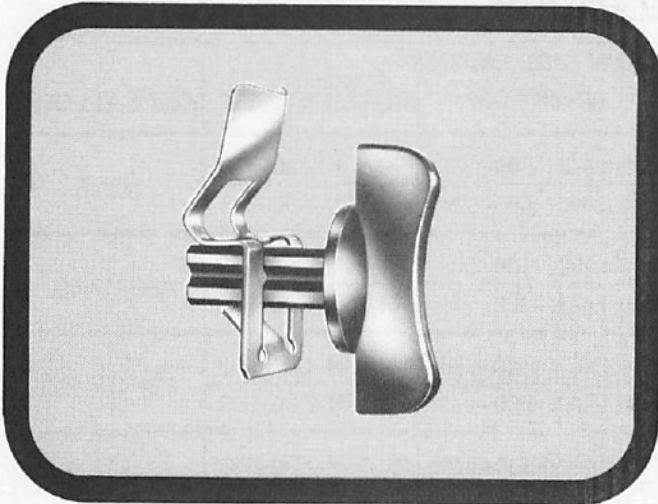

**LOW-COST ¼ TURN LATCHING**

DP-137 Series Pawl Latches provide basic ¼-turn latching at low installed cost. Studs, in black acetal plastic, are available with attractive wing, knob or slotted heads. One-step installation consists of pushing the spring-steel pawl onto the stud and up against the underside of the panel. One-way tabs on the pawl maintain its position and provide secure stud retention. Latch closes under spring tension. No spacers needed.

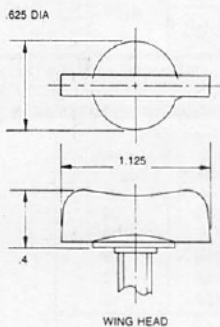
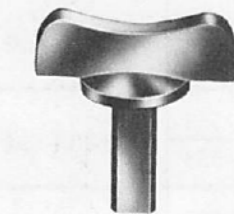

**STUD, WING HEAD**  
 DP 137-1W

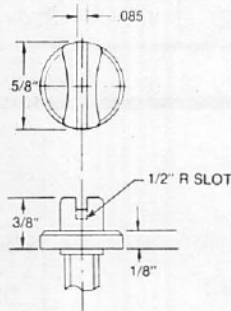

**STUD, SLOTTED KNOB**  
 DP137-1M

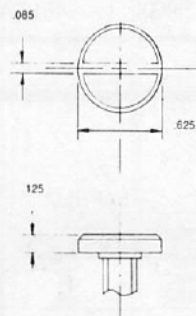

**STUD, SLOTTED**  
 DP 137-1S

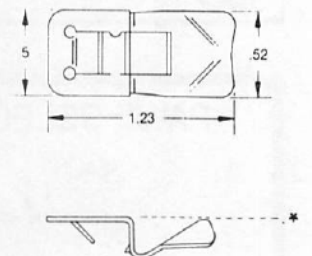

**PAWL**  
 DP 137-2S  
 DP 137-2L

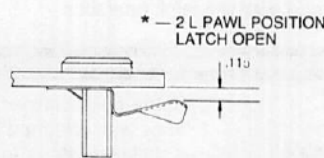
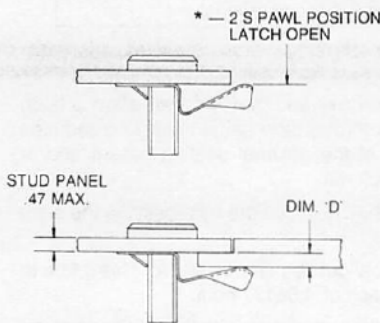

**RECOMMENDED PAWL DEFLECTION**  
 — Latch Locked —  
 .010" (Locked Tension 2 lb.)  
 to  
 .135" (Locked Tension 8 lb.)

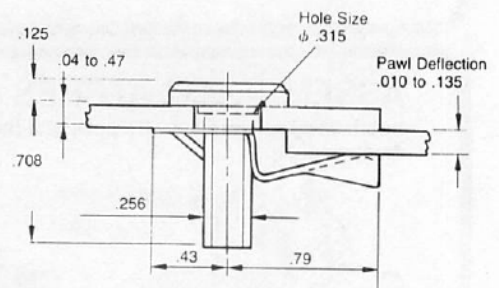

**STUD MATERIAL:** Black Acetal copolymer. Material burning rating code UL94HB. ASTM E-162. F.S.I. - 130 -40°F (-40°C) to +194°F (+90°C)

DIM. 'D'	USE PAWL
.010" to .125	-2S
.126"	

# PUSH-ACTION FASTENERS

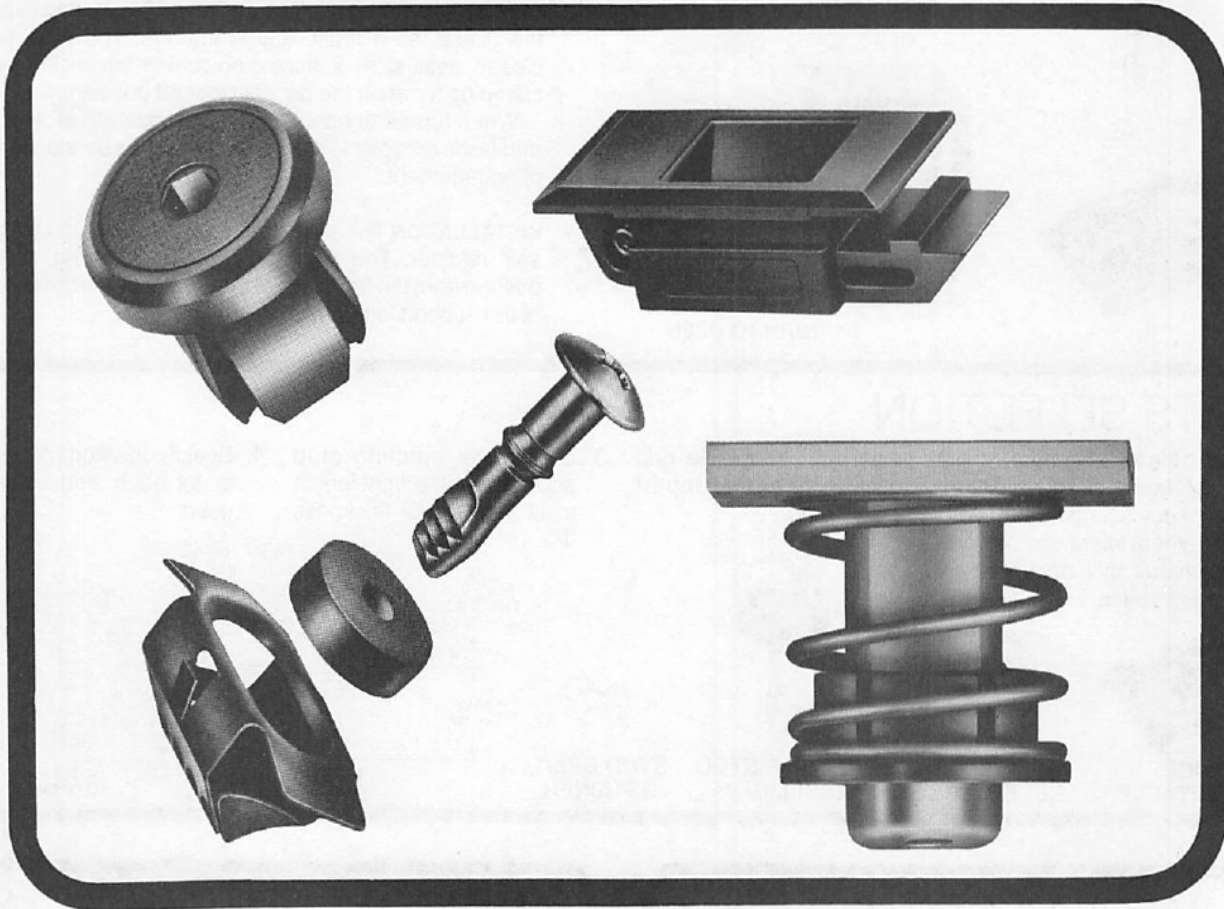

Access fasteners that operate, at least to close, by push-action are growing in popularity. This is due, in part, to the simplicity and speed of the operating motion. At the same time, push-action fasteners in general share a tolerance for thickness variation of the fastened parts that is wide compared to other types of quick-acting fastener.

The fasteners in this section are some of the most convenient to operate of the type that secure panels over supports. In addition, each one offers rapid and tool-free installation procedure.

**NOTE** —The selection and installation planning of fasteners can influence the security of the fastened parts. Dzus product information and support service is intended for use only by persons with mechanical engineering qualifications sufficient to manage the responsibilities of:

1. Analyzing fastener performance in relation to the service to be met, and
2. Planning appropriate fastening locations and installations.

# FAST DZUS FASTENING

## PUSH-TO-LOCK 1/4-TURN TO OPEN STEEL FASTENER PILOT

EJECTING STUD ASSEMBLY



PUSH TO LOCK

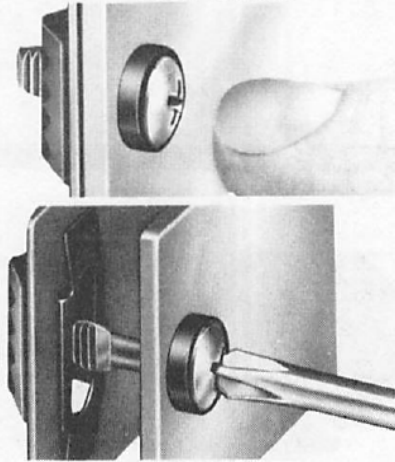

1/4-TURN TO OPEN

The Pilot fastener offers push-to-lock closing action with 1/4-turn screwdriver opening. In locked position it exerts a vibration-resistant clamping force on its panel.

Pilot operation is simple and obvious, with a crisp "feel" to guide the user.

As Pilot engages for locking, internal ridges on the receptacle's spring blades turn the stud's notched face against the blades so it must ratchet through. The stud is pushed closed against a compression spring which then exerts a clamping force on the panel in locked position.

When turned to open, the smooth tapered face of the stud meets the receptacle blades and the stud's spring pulls it up out of engagement.

**INSTALLATION** The stud is retained in its panel by the push-on split retainer. The receptacle is self-retaining once hand-pushed from the front face of the support. No access to the rear of the support is needed.

### PARTS SELECTION

1. Choose the wide or compact receptacle style. The wide style offers a large lateral engagement tolerance, and the compact style occupies minimum space.
2. Select the receptacle grip range to fit your support thickness 'Q'.
3. Select the ejecting stud range to fit your panel thickness 'P'.
4. Specify one stud split retainer for each stud assembly used.



WIDE RECEPTACLE



COMPACT RECEPTACLE



EJECTING STUD ASSEMBLY



STUD SPLIT RETAINER

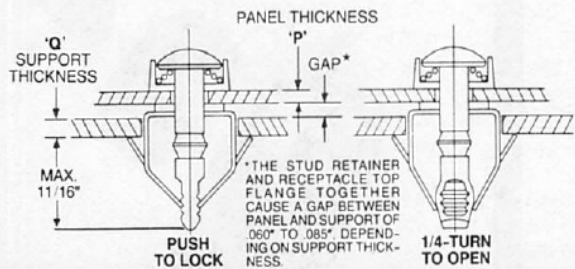

### WIDE RECEPTACLE

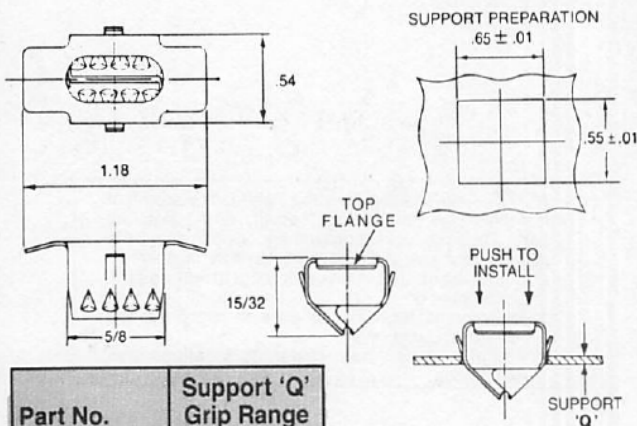

Part No.	Support 'Q' Grip Range
285-201-161	.025—.049
285-202-161	.050—.069
285-203-161	.070—.089
285-204-161	.090—.109
285-205-161	.110—.129

**Material:** Spring Steel  
**Finish:** Zinc Phosphate

### COMPACT RECEPTACLE

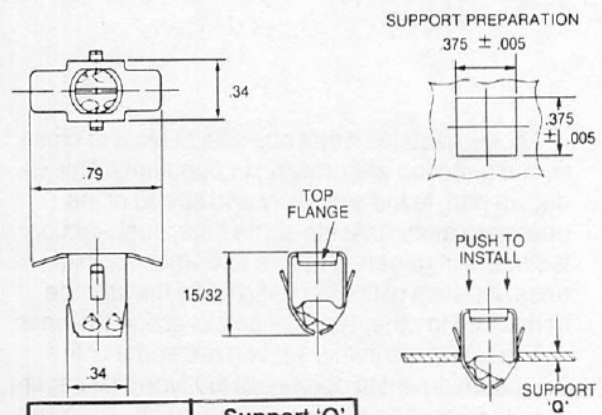

Part No.	Support 'Q' Grip Range
285 101 161	.025—.049
285 102 161	.050—.069
285 103 161	.070—.089

**Material:** Spring Steel  
**Finish:** Zinc Phosphate

# PUSH-TO-LOCK 1/4-TURN TO OPEN STEEL FASTENER PILOT



## STUDS

Studs may be installed as part of an ejecting stud assembly, or by themselves, stud head against the panel. The ejecting stud assemblies are retained with a thin split retainer. Studs installed alone are retained with a thicker compressible neoprene washer.

The standard head style is Phillips recess, which does not resist the stud's self-rotation as finger pressure is applied in closing. Hex recess and straight slot heads are available on special order. Minimum quantity for special studs: 50,000 pieces.

**Material:** Case-hardened steel.  
**Finish:** Zinc plate,  
black chromate.

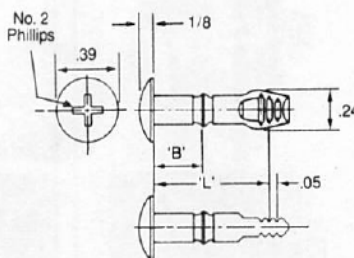

## PANEL PREPARATION

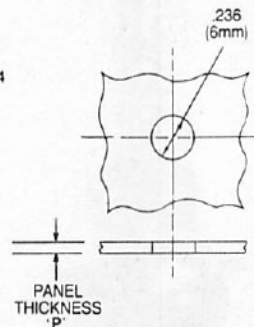

## EJECTING STUD ASSEMBLY INSTALLATIONS

### STUD SPLIT RETAINER

Used with ejecting stud assemblies. After the stud assembly is placed in its panel hole, the split retainer is pushed onto the stud shank from the side, between the shank's retaining collar and the panel underside.

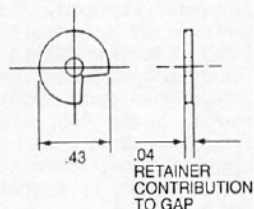

**Material:** white thermoplastic  
Part callout: 275-203-040

**Retainer Installation:** Tool T1310 manually attaches retainer with sideways push action.

### EJECTING STUD ASSEMBLIES

The ejecting stud assembly is sold as a unit. Select the right assembly for your panel thickness 'P', from the table below. Order one stud split retainer for each stud assembly.

**Material:**  
**Cup:** Black thermoplastic  
**Ejecting Spring:** Stainless steel

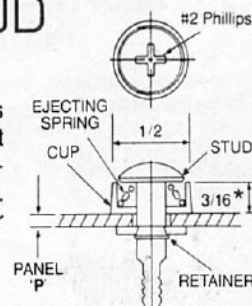

\*WHEN LOCKED, STUD HEAD IS ABOVE CUP, MAKING OVERALL HEIGHT APPROX. 1/4"

## EJECTING STUD ASSEMBLY SELECTION

Select the ejecting stud assembly tabulated for the thickness of your stud panel 'P'.

A gap between panel and support caused by the stud split retainer and receptacle top flange, is assumed in the table and should not be added.

THICKNESS OF PANEL 'P'	EJECTING STUD ASSEMBLY CALLOUT	STUD DIM. 'B'	STUD DIM. 'L'
.020 TO .120	290-718-191	.35	.70
.100 TO .200	290-720-191	.43	.79

## LOW PROFILE STUD INSTALLATIONS

If the height of the ejecting stud assembly above the panel is excessive, the stud can be installed head-against-panel, using a compressible neoprene washer behind the panel as a combined retainer and spring member. Note, however, that an

increased gap between panel and support will result with use of the neoprene washer. See the following page for details on low profile stud installations.



Get quote >>

Angic Global Solutions

1-888-872-0690

<https://www.AngicGlobal.com> Sales@AngicGlobal.com

# FAST DZUS FASTENING

## PUSH-TO-LOCK 1/4-TURN TO OPEN STEEL FASTENER PILOT

### LOW PROFILE ASSEMBLY

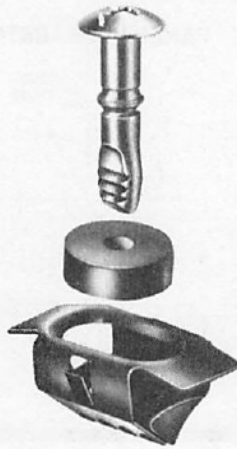

### PUSH TO LOCK

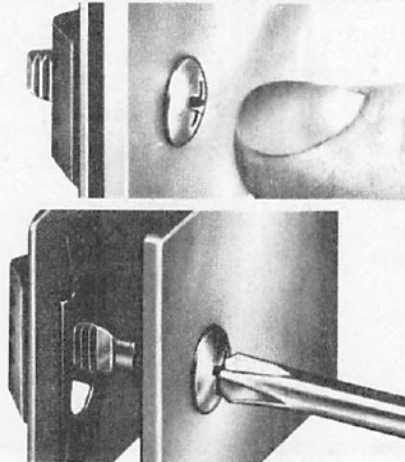

### 1/4-TURN TO OPEN

### LOW PROFILE STUD WITH NEOPRENE WASHER

The Pilot fastener is locked against spring tension in order to exert a clamping force on the fastened panel and provide for smooth release. An alternative to the ejecting stud assembly for this purpose is a compressible neoprene washer on the stud shank behind the panel. This washer will widen the gap between panel and support (to around .110") but will in turn provide both a low head profile and a solid lock with zero sheet separation under tensile load.

A special modification of the neoprene washer installation can provide a push-panel locking action, by which locking is achieved with a push of the panel near the stud.

Receptacle Selection: Same as for ejecting stud assemblies.

Panel Preparation: Same as for ejecting stud assemblies.

### NEOPRENE WASHER STUD INSTALLATION

The stud is retained by pushing the neoprene washer over its shank as shown. This will cause a gap between panel and support of about .110".

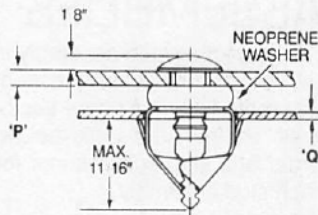

### SPECIAL PUSH-PANEL STUD INSTALLATION

The stud can lock by pushing the panel in its vicinity, if the stud is retained without vertical play. This may be achieved using a special stud having a 'B' Dim. Just .040" longer than panel thickness, to snugly fit the .040" retainer. A neoprene washer is then added to provide locking tension. Minimum order quantity for special studs: 25,000 pieces.

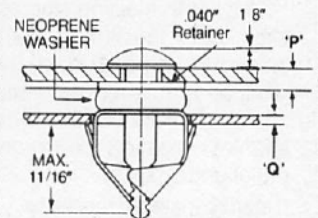

FOR PUSH-PANEL STUDS ADD .040" RETAINER THICKNESS TO PANEL THICKNESS FOR DIM. 'P'

### WASHERS FOR WIDE RECEPTACLES

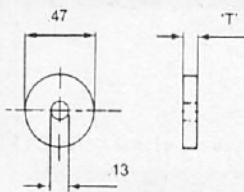

Part No.	Thickness 'T'
275 135 400	.14
275 140 400	.16
275 145 400	.18
275 150 400	.20

WASHER COMPRESSION: .040-.080

Material: Neoprene rubber  
Color: Black

### WASHERS FOR COMPACT RECEPTACLES

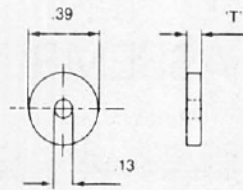

Part No.	Thickness 'T'
275 035 400	.14
275 040 400	.16
275 045 400	.18
275 050 400	.20

WASHER COMPRESSION: .040-.080

Material: Neoprene rubber  
Color: Black

### STUD/WASHER SELECTION FOR WIDE RECEPTACLES

Panel 'P'	Part No.		Stud 'B'	Stud 'L'
	Stud	Washer		
.050-.069	265 716 191	275 140 400	28	.63
.070-.089	265 716 191	275 135 400	28	.63
.090-.109	265 718 191	275 150 400	35	.70
.110-.129	265 718 191	275 145 400	35	.70
.130-.149	265 718 191	275 140 400	35	.70
.150-.169	265 718 191	275 135 400	35	.70
.170-.189	265 720 191	275 150 400	43	.79

### STUD/WASHER SELECTION FOR COMPACT RECEPTACLES

Panel 'P'	Part No.		Stud 'B'	Stud 'L'
	Stud	Washer		
.050-.069	265 716 191	275 040 400	28	.63
.070-.089	265 716 191	275 035 400	28	.63
.090-.109	265 718 191	275 050 400	35	.70
.110-.129	265 718 191	275 045 400	35	.70
.130-.149	265 718 191	275 040 400	35	.70
.150-.169	265 718 191	275 035 400	35	.70
.170-.189	265 720 191	275 050 400	43	.79

# PUSH-TO-LOCK 1/4-TURN TO OPEN PLASTIC FASTENER ARROW

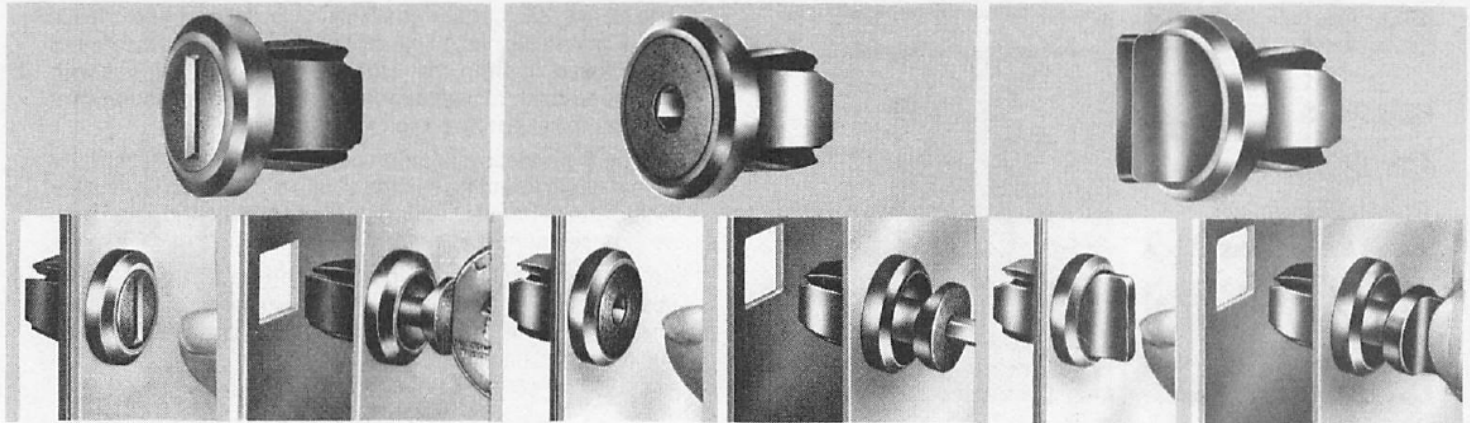

## ARROW

Arrow Plastic Fasteners consist of a receptacle which is self-retained in a square hole in the fastened panel, and a stud within the receptacle. Arrow closes by pushing the stud inward with finger pressure. It opens with a quarter-turn of the stud, using fingers, a coin, or a hex key, depending on head style. In closing, Arrow passes through a square hole in the support material, where its four prongs lock as they are expanded by the stud.

Although this is a small fastener, Arrow is designed to stand up to frequent use on lightly-loaded access panels. Its prongs are rugged and the low-profile head is both unobtrusive and well-protected against accidental damage.

## SPECIFICATIONS

Designed Max. Axial Load: 11 lb.  
Ultimate Axial Load: 56 lb.  
Designed Max. Shear Load: 28 lb.  
Ultimate Shear Load: 140 lb.  
Operating Temperature: -20° to +180°F

## MATERIAL

Acetal copolymer resin. Material burning rating code UL 94 HB. ASTM E-162 flame spread index: 130. Standard color is black.

## RECEPTACLE SELECTION

1. CHOOSE THE RECEPTACLE THAT FITS YOUR PANEL THICKNESS (P).
2. CHECK THAT THE COMBINED THICKNESS OF YOUR PANEL AND SUPPORT (T) IS WITHIN LISTED LIMITS.

**THIN PANEL RECEPTACLE**  
**200-802-010**  
Panel Thickness P: .020 to .070  
Panel Plus Support T: .080 to .200  
Retaining Undercut B: .070  
Length Under Head H: .48

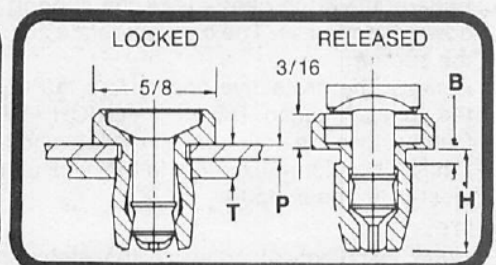

**THICK PANEL RECEPTACLE**  
**201-802-010**  
Panel Thickness P: .071 to .125  
Panel Plus Support T: .135 to .250  
Retaining Undercut B: .125  
Length Under Head H: .54

## STUD SELECTION

3. CHOOSE A STUD HEAD STYLE, IN THE LENGTH NEEDED BY YOUR RECEPTACLE.

**SLOT**



For 200 Receptacle  
**200-711-010**  
(L: .50)  
For 201 Receptacle  
**201-711-010**  
(L: .55)

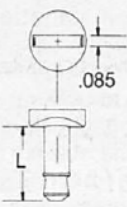

**HEX RECESS**



For 200 Receptacle  
**200-701-010**  
(L: .50)  
For 201 Receptacle  
**201-701-010**  
(L: .55)

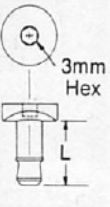

**KNOB**



For 200 Receptacle  
**200-721-010**  
(L: .50)  
For 201 Receptacle  
**201-721-010**  
(L: .55)

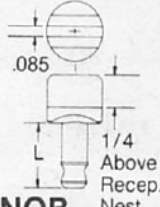

## INSTALLATION

Arrow studs and receptacles are packed separately. The receptacle is easily snapped into a square hole from the panel front, and it is self-retained. The stud is then pushed into the receptacle until a retaining detent is felt to be overcome. A small plastic mallet may be convenient for stud insertion. The fastener is now ready for use.

## HOLE DIMENSIONS

Panel Hole: .360 ±.005 square  
Support Hole: .375 ±.005 square  
Hole Misalignment: ±.020



Get quote »

Angic Global Solutions

1-888-872-0690

<https://www.AngicGlobal.com> [Sales@AngicGlobal.com](mailto:Sales@AngicGlobal.com)

## PUSH-PANEL ACTION CONCEALED LATCH PINLATCH SERIES 225

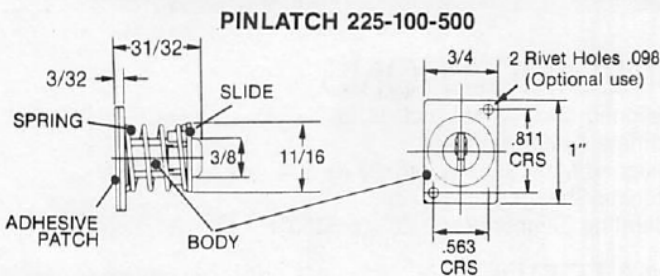
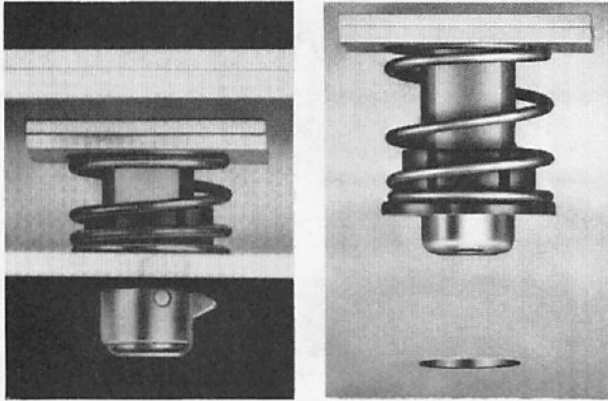

### MATERIAL

**Body:** Diecast zinc with self adhesive backing, protected by paper. Finish natural zinc.

**Spring, Locking Cam:** stainless steel.

**Slide:** Black thermoplastic.

### LATCH INSTALLATION

1. Engage the latch centrally in the support hole. Press down and release. The cam will rotate and lock behind the support.
2. Remove the protective paper from the top surface of the adhesive patch. **DO NOT TOUCH ADHESIVE.\***
3. Gently close the door against the latch and press down firmly. The latch will adhere to the back of the door and eject from the support.

#### NOTE:

When installed with adhesive, the latch is designed for operating loads only. If continuous loads are foreseen, latch may be riveted to panel.

### PANEL HOLES (IF LATCH RIVETED)

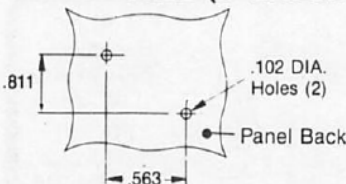

\*Adhesive and contact surfaces *must* be clean. A fingerprint can reduce adhesive joint strength by 50%.

### SUPPORT HOLE, NO RECEPTACLE USED

Prepare a 13/32 or 10mm support hole under the latch center. This hole may be elongated if misalignment tolerance is needed.

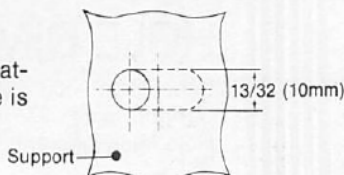

The Series 225 concealed Pinlatch is opened and closed with a gentle push of its panel. The panel must be located so it is closed flush in the latch's locked position, but with clearance back to its support so it can be pushed inward enough to release the latch locking cam.

The only cabinet preparation needed for latch installation is to make one round hole in the support. The latch is installed by locking it into the support hole and closing the panel onto its exposed adhesive patch.

An optional floating receptacle is offered in case panel misalignment is expected or support material is softer than mild steel. The latch may also be riveted to its panel if it will be subject to continuous load when locked.

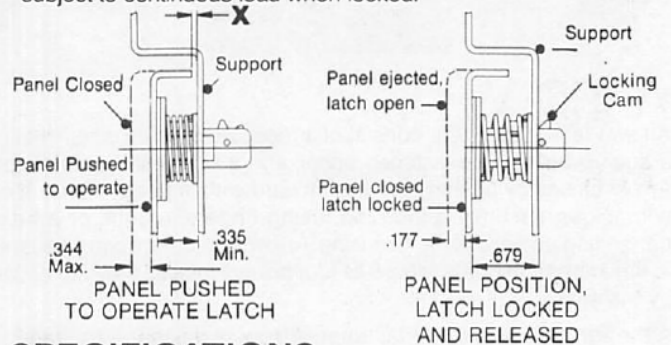

### SPECIFICATIONS

Support thickness range: .047 to .118

Latch float: .008

Latch compression to operate: .344.

(Ensure clearance remains at **X** and at latch stud end.)

Latch ejection when released: .177

Latch swing arc radius (Hinge to latch centers): 6.0 Min.

### FLOATING RECEPTACLE (OPTIONAL) 225-600-200

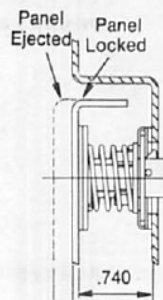
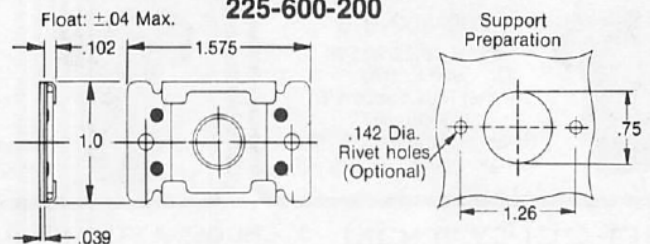

### FLOATING RECEPTACLE INSTALLATION

1. Floating receptacle installation requires a .740 gap between panel back and top of support. Pressing panel for operation closes gap to .433.
2. For adhesive mounting, check receptacle and support around hole are clean, remove paper backing from one side of adhesive patch, and press patch onto receptacle. **DO NOT TOUCH ADHESIVE.\***
3. Remove second paper and press receptacle into place over support hole surface closest to latch.

**MATERIAL:** Receptacle housing and plate: Stainless steel. An adhesive retaining patch is supplied with the receptacle, unattached.

# PUSH PANEL TO LOCK SLIDE TO OPEN PLASTIC SLIDE LATCH SERIES 404

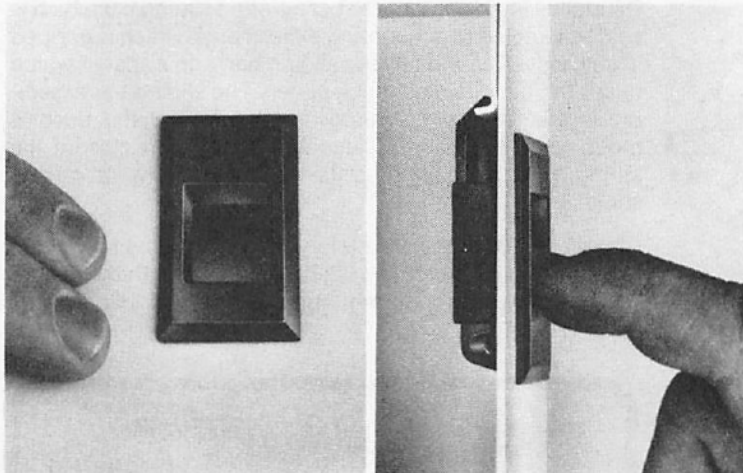

PUSH PANEL TO LOCK

SLIDE LATCH TO OPEN

The Series 404 Plastic Slide Latch is held in the closed position by spring tension. A stainless steel spring is nested at the back end of the one-piece latch body, and is contacting the back edge of the panel hole.

When the panel is pushed closed, the sloped pawl edge meets the support corner and slides the latch back. As the panel closes fully, the pawl clears the edge of the support and the spring slides the latch forward to the closed position.

The panel is opened by sliding the latch back with a finger.

This black thermoplastic latch has a clean, flush appearance. The panel hole is always concealed.

## PARTS SELECTION

1. Smooth and snug pawl closure is assured by designing the depth of your support edge so that total grip **G** equals  $.25" \pm .005"$ .
2. Panel thickness from  $.043$  to  $.083$  is accommodated by selecting the snap-clip as tabulated.

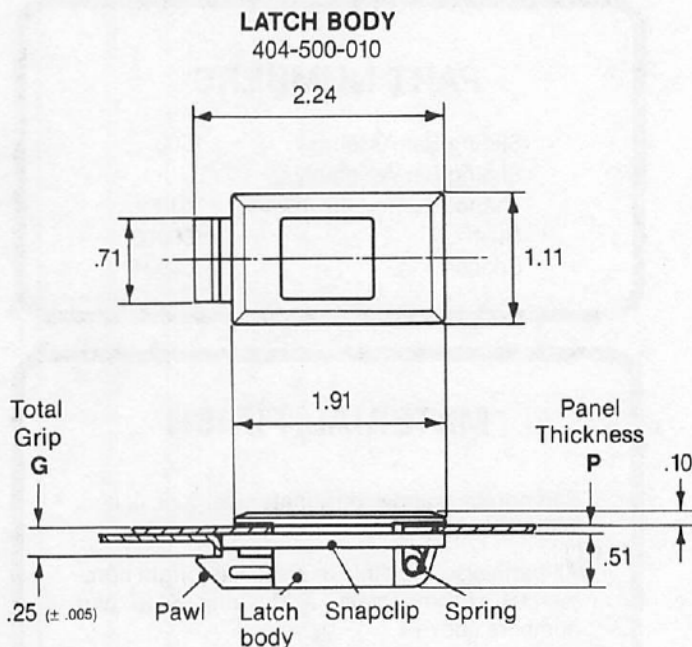

## INSTALLATION

1. Place latch body, pawl end first, into panel hole.
2. Push back (spring) end of latch body into hole.
3. Slide appropriate snapclip (see table) onto latch body underside, starting at pawl end.

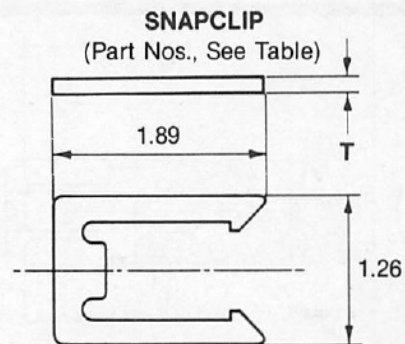

SNAPCLIP PART NO.	T SNAPCLIP THICKNESS	P PANEL THICKNESS
404-912-010	.125	.043-.051
404-916-010	.110	.055-.067
404-920-010	.095	.071-.083

## HOLE DIMENSION, LOCATION

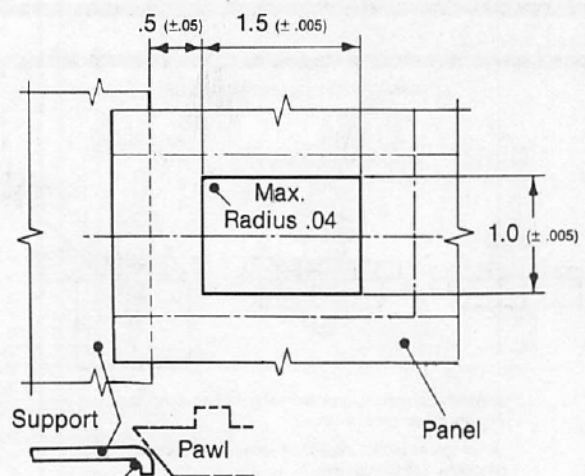

(Min. Radius .02 needed for smooth sliding action)



Get quote >>

Angic Global Solutions

1-888-872-0690

95

<https://www.AngicGlobal.com> [Sales@AngicGlobal.com](mailto:Sales@AngicGlobal.com)

# SLIDE LATCH

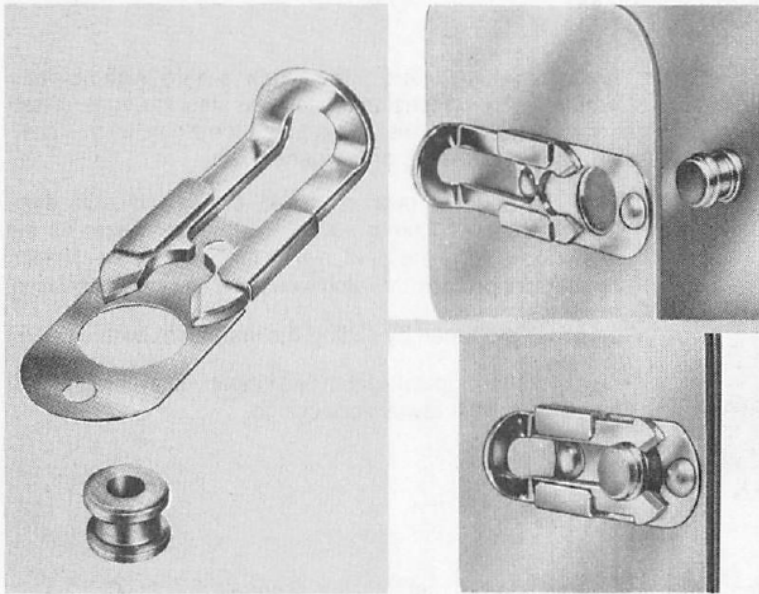

Dzus slide latch parts consist of a slotted sliding bar which is sold assembled to a mounting plate, a bush which is gripped in its grooved section by the sliding bar, and a spacer which raises the bush to clear thick panels. The sliding bar assembly is attached to the removable panel and the bush is mounted to the panel's stationary support. In closure the spring action of the bar resists opening under vibration and shock loads.

Clearance above the slide latch need only allow for fingers to grip the sliding bar. The latch is also sold with the handle pointing downward for mounting on the underside of the panel (See Fig. 2).

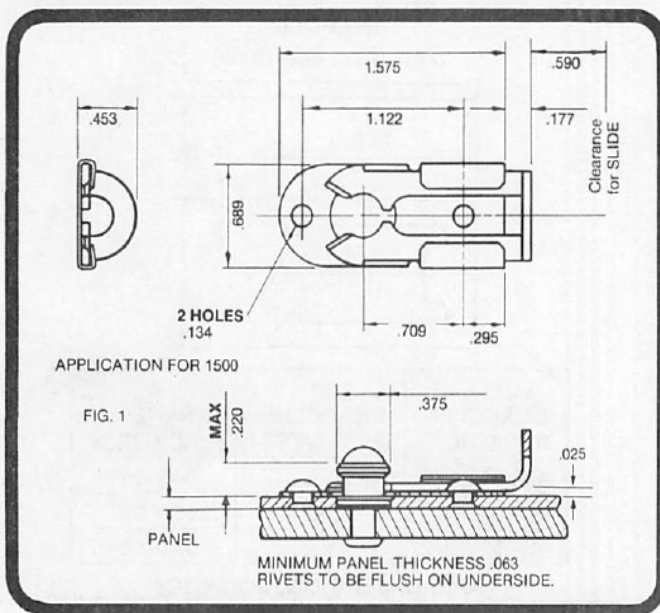
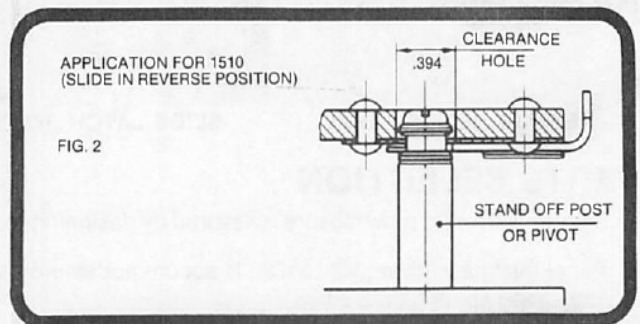

### PART NUMBERS

Sliding Bar Assembly:	1500
Sliding Bar Assembly, handle turned downward:	1510
Bush	150003
Spacer:	150004

### MATERIAL, FINISH

Part numbers above designate steel, zinc plated, with yellow chromate finish.

All parts also available in steel with bright commercial chrome plate. Add suffix K to part numbers above.

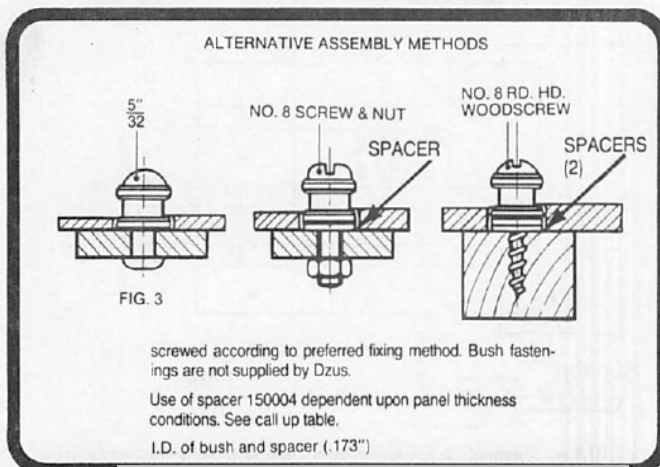

### SPACER CALL-UP

PANEL THICKNESS	150004 SPACERS REQUIRED
.046 — .080	None
.081 — .128	One
.129 — .160	Two

# EQUIVALENT TABLES

## FRACTIONAL/DECIMAL

$\frac{1}{64}$	.015625
$\frac{1}{32}$	.03125
$\frac{3}{64}$	.046875
$\frac{1}{16}$	.0625
$\frac{5}{64}$	.078125
$\frac{3}{32}$	.09375
$\frac{7}{64}$	.109375
$\frac{1}{8}$	.125
$\frac{9}{64}$	.140625
$\frac{5}{32}$	.15625
$\frac{11}{64}$	.171875
$\frac{3}{16}$	.1875
$\frac{13}{64}$	.203125
$\frac{7}{32}$	.21875
$\frac{15}{64}$	.234375
$\frac{1}{4}$	.250
$\frac{17}{64}$	.265625
$\frac{9}{32}$	.28125
$\frac{19}{64}$	.296875
$\frac{5}{16}$	.3125
$\frac{21}{64}$	.328125
$\frac{11}{32}$	.34375
$\frac{23}{64}$	.359375
$\frac{3}{8}$	.375
$\frac{25}{64}$	.390625
$\frac{13}{32}$	.40625
$\frac{27}{64}$	.421875
$\frac{7}{16}$	.4375
$\frac{29}{64}$	.453125
$\frac{15}{32}$	.46875
$\frac{31}{64}$	.484375
$\frac{1}{2}$	.500
$\frac{33}{64}$	.515625
$\frac{17}{32}$	.53125
$\frac{35}{64}$	.546875
$\frac{9}{16}$	.5625
$\frac{37}{64}$	.578125
$\frac{19}{32}$	.59375
$\frac{39}{64}$	.609375
$\frac{5}{8}$	.625
$\frac{41}{64}$	.640625
$\frac{21}{32}$	.65625
$\frac{43}{64}$	.671875
$\frac{11}{16}$	.6875
$\frac{45}{64}$	.703125
$\frac{23}{32}$	.71875
$\frac{47}{64}$	.734375
$\frac{3}{4}$	.750
$\frac{49}{64}$	.765625
$\frac{25}{32}$	.78125
$\frac{51}{64}$	.796875
$\frac{13}{16}$	.8125
$\frac{53}{64}$	.828125
$\frac{27}{32}$	.84375
$\frac{55}{64}$	.859375
$\frac{7}{8}$	.875
$\frac{57}{64}$	.890625
$\frac{29}{32}$	.90625
$\frac{59}{64}$	.921875
$\frac{15}{16}$	.9375
$\frac{61}{64}$	.953125
$\frac{31}{32}$	.96875
$\frac{63}{64}$	.984375
1	1.000

## INCH/METRIC

Inches Dec.	mm	Inches Dec.	mm	Inches Dec.	mm
0.01	0.2540	0.35	8.8900	0.69	17.5260
0.02	0.5080	0.36	9.1440	0.70	17.7800
0.03	0.7620	0.37	9.3980	0.71	18.0340
0.04	1.0160	0.38	9.6520	0.72	18.2880
0.05	1.2700	0.39	9.9060	0.73	18.5420
0.06	1.5240	0.40	10.1600	0.74	18.7960
0.07	1.7780	0.41	10.4140	0.75	19.0500
0.08	2.0320	0.42	10.6680	0.76	19.3040
0.09	2.2860	0.43	10.9220	0.77	19.5580
0.10	2.5400	0.44	11.1760	0.78	19.8120
0.11	2.7940	0.45	11.4300	0.79	20.0660
0.12	3.0480	0.46	11.6840	0.80	20.3200
0.13	3.3020	0.47	11.9380	0.81	20.5740
0.14	3.5560	0.48	12.1920	0.82	20.8280
0.15	3.8100	0.49	12.4460	0.83	21.0820
0.16	4.0640	0.50	12.7000	0.84	21.3360
0.17	4.3180	0.51	12.9540	0.85	21.5900
0.18	4.5720	0.52	13.2080	0.86	21.8440
0.19	4.8260	0.53	13.4620	0.87	22.0980
0.20	5.0800	0.54	13.7160	0.88	22.3530
0.21	5.3340	0.55	13.9700	0.89	22.6060
0.22	5.5880	0.56	14.2240	0.90	22.8600
0.23	5.8420	0.57	14.4780	0.91	23.1140
0.24	6.0960	0.58	14.7320	0.92	23.3680
0.25	6.3500	0.59	14.9860	0.93	23.6220
0.26	6.6040	0.60	15.2400	0.94	23.8760
0.27	6.8580	0.61	15.4940	0.95	24.1300
0.28	7.1120	0.62	15.7480	0.96	24.3840
0.29	7.3660	0.63	16.0020	0.97	24.6380
0.30	7.6200	0.64	16.2560	0.98	24.8920
0.31	7.8740	0.65	16.5100	0.99	25.1460
0.32	8.1280	0.66	16.7640	1.00	25.4000
0.33	8.3820	0.67	17.0180		
0.34	8.6360	0.68	17.2720		

## METRIC/INCH

mm	Inches	mm	Inches	mm	Inches	mm	Inches
0.01	.00039	0.39	.01535	0.77	.03032	15	.59055
0.02	.00079	0.40	.01575	0.78	.03071	16	.62992
0.03	.00118	0.41	.01614	0.79	.03110	17	.66929
0.04	.00157	0.42	.01654	0.80	.03150	18	.70866
0.05	.00197	0.43	.01693	0.81	.03189	19	.74803
0.06	.00236	0.44	.01732	0.82	.03228	20	.78740
0.07	.00276	0.45	.01772	0.83	.03268	21	.82677
0.08	.00315	0.46	.01811	0.84	.03307	22	.86614
0.09	.00354	0.47	.01850	0.85	.03346	23	.90551
0.10	.00394	0.48	.01890	0.86	.03386	24	.94488
0.11	.00433	0.49	.01929	0.87	.03425	25	.98425
0.12	.00472	0.50	.01969	0.88	.03465	26	1.02362
0.13	.00512	0.51	.02008	0.89	.03504	27	1.06299
0.14	.00551	0.52	.02047	0.90	.03543	28	1.10236
0.15	.00591	0.53	.02087	0.91	.03583	29	1.14173
0.16	.00630	0.54	.02126	0.92	.03622	30	1.18110
0.17	.00669	0.55	.02165	0.93	.03661	31	1.22047
0.18	.00709	0.56	.02205	0.94	.03701	32	1.25984
0.19	.00748	0.57	.02244	0.95	.03740	33	1.29921
0.20	.00787	0.58	.02283	0.96	.03780	34	1.33858
0.21	.00827	0.59	.02323	0.97	.03819	35	1.37795
0.22	.00866	0.60	.02362	0.98	.03858	36	1.41732
0.23	.00906	0.61	.02402	0.99	.03898	37	1.45669
0.24	.00945	0.62	.02441	1.00	.03937	38	1.49606
0.25	.00984	0.63	.02480	1	.03937	39	1.53543
0.26	.01024	0.64	.02520	2	.07874	40	1.57480
0.27	.01063	0.65	.02559	3	.11811	41	1.61417
0.28	.01102	0.66	.02598	4	.15748	42	1.65354
0.29	.01142	0.67	.02638	5	.19685	43	1.69291
0.30	.01181	0.68	.02677	6	.23622	44	1.73228
0.31	.01220	0.69	.02717	7	.27559	45	1.77165
0.32	.01260	0.70	.02755	8	.31496	46	1.81102
0.33	.01299	0.71	.02795	9	.35433	47	1.85039
0.34	.01339	0.72	.02835	10	.39370	48	1.88976
0.35	.01378	0.73	.02874	11	.43307	49	1.92913
0.36	.01417	0.74	.02913	12	.47244	50	1.96850
0.37	.01457	0.75	.02953	13	.51181		
0.38	.01496	0.76	.02992	14	.55118		

## GAUGES

American or Brown & Sharpe for Aluminum & Brass Sheet	Gauge	U.S. Standard Gauge for Steel & Plate Iron & Steel
.3648	00	.3437
.3249	0	.3125
.2893	1	.2812
.2576	2	.2656
.2294	3	.2391
.2043	4	.2242
.1819	5	.2092
.1620	6	.1943
.1443	7	.1793
.1285	8	.1644
.1144	9	.1495
.1019	10	.1345
.0907	11	.1196
.0808	12	.1046
.0720	13	.0897
.0641	14	.0747
.0571	15	.0673
.0508	16	.0598
.0453	17	.0538
.0403	18	.0478
.0359	19	.0418
.0320	20	.0359
.0285	21	.0329
.0253	22	.0299
.0226	23	.0269
.0201	24	.0239
.0179	25	.0209
.0159	26	.0179

## DZUS CAN HELP WITH YOUR SPECIAL FASTENING PROBLEM.

We can work with you in developing a special design. Or, we may be able to modify a standard product to suit your requirements. It's also possible that the solution is in existing special tooling, an unconventional installation method, or a just-released product.

The DZUS Technical Staff is always at your service, without obligation.



Get quote >>

Angic Global Solutions

1-888-872-0690

<https://www.AngicGlobal.com> Sales@AngicGlobal.com

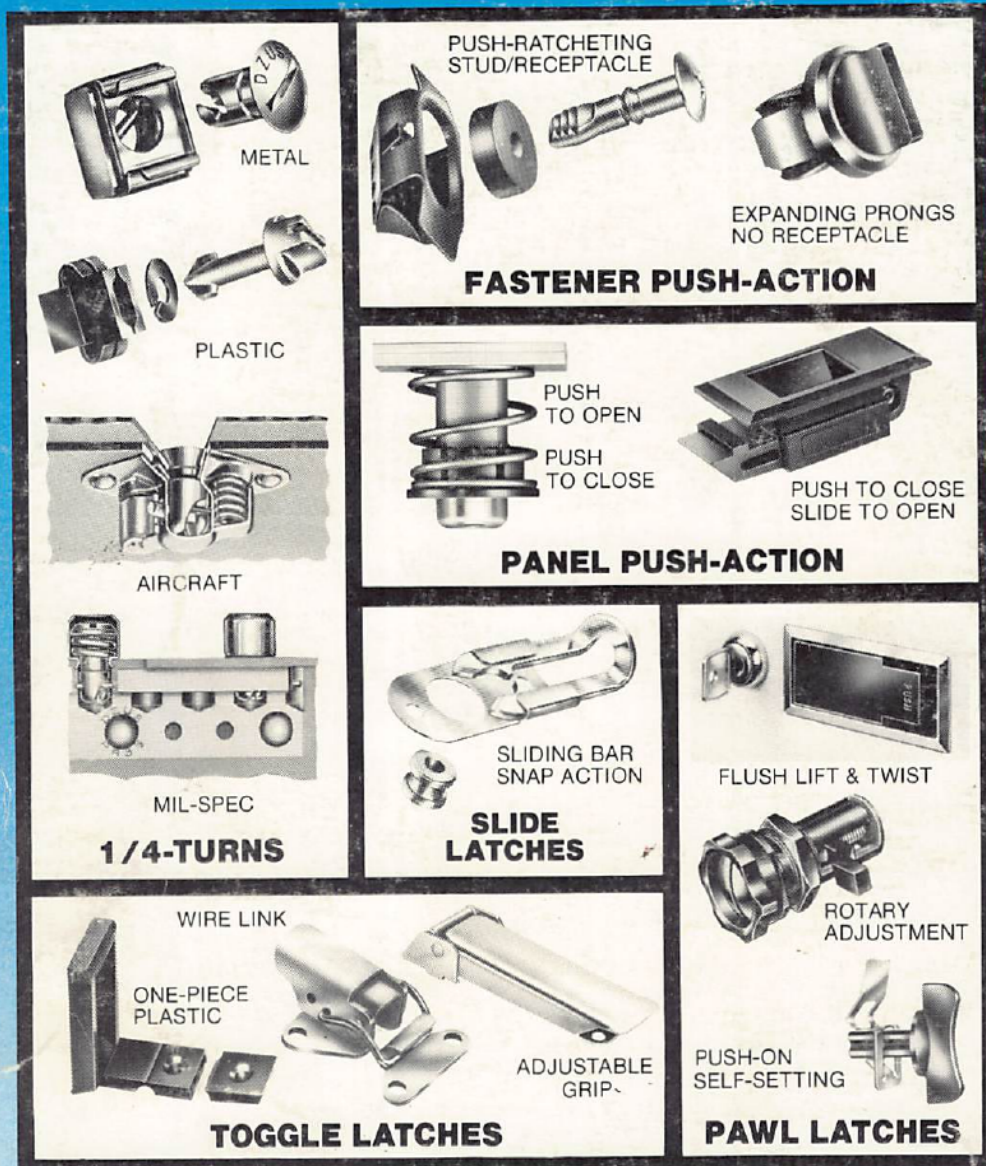

## ACCESS FASTENERS FOR PANELS, COVERS AND DETACHABLE PARTS

The information contained in this catalog is correct to the best of our knowledge. We reserve the right, however, to make changes in dimensions and materials without notice.



**DZUS FASTENER CO. INC.**

425 Union Blvd., West Islip, N.Y. 11795

(516) 669-0494 Telex: 71-4974043 FAX: 516-669-0785



Get quote >>

Angic Global Solutions

1-888-872-0690

<https://www.AngicGlobal.com> Sales@AngicGlobal.com