



ENGINEERING MANUAL EM-7



AVK INDUSTRIAL PRODUCTS

A **PCC** COMPANY

MARKET LEADER IN BLIND THREADED INSERTS AND STUDS

AVK's Quality Management System is registered to ISO/TS16949 and ISO9001
AVK's Environmental Management System is registered to ISO14001



Get quote >>

AVK is committed to protecting our environment. All standard in-house plating is RoHS compliant. AVK reserves the right to change specifications without notice. RoHS compliant

Angic Global Solutions

1-888-872-0690

<https://www.AngicGlobal.com> Sales@AngicGlobal.com



WELCOME TO THE WORLD OF AVK

AVK INDUSTRIAL PRODUCTS, located in Southern California, is a Precision Castparts Company. AVK manufactures blind installed threaded fasteners for transportation and general industrial markets world-wide. We feature product lines of both unified (INCH) and metric fasteners along with numerous special designs that meet customer application requirements.



At AVK, we are dedicated to...

“IMPROVING THE WAY WE ASSEMBLE THE WORLD™”

BLIND INSTALLED THREADED INSERTS AND STUDS

A blind installed threaded fastener is defined as a fastener with internal or external threads that can be installed into a panel, tube or other structure from the front side without need to see or access the backside, or “blind” side to complete the installation. Once installed the fastener remains captive to which a mating component can be attached using standard hardware.

This engineering manual contains technical information on all AVK standardized product lines including sales drawings and information on installation tooling.



WARRANTY

LIMITED WARRANTY AND EXCLUSIVE REMEDY

AVK Industrial Products division is a subsidiary of Precision Castparts (“Seller”). Seller warrants that products sold hereunder conform to industry standards specified herein and will be free from defects in materials and workmanship. THIS WARRANTY IS EXPRESSLY GIVEN IN LIEU OF ANY AND ALL OTHER EXPRESS OR IMPLIED WARRANTIES, INCLUDING ANY IMPLIED WARRANTY OF MERCHANTABILITY OR FITNESS FOR A PARTICULAR PURPOSE, AND IN LIEU OF ANY OTHER OBLIGATION ON THE PART OR THE SELLER. Seller will, at its option, repair or replace free of charge (excluding all shipping and handling costs) any products which have not been subject to misuse, abuse or modification and which in its sole determination were not manufactured in compliance with the warranty given above.

It is expressly understood that any technical advice furnished by or on behalf of Seller with respect to the use of its goods or services is given without charge, and Seller assumes no obligations or liability for the advice given or results obtained. All such results being given and accepted is at Buyer’s Risk.

THE REMEDY PROVIDED FOR HEREIN SHALL BE THE EXCLUSIVE REMEDY FOR ANY BREACH OF WARRANTY OR ANY CLAIM ARISING IN ANY WAY OUT OF THE MANUFACTURE, SALE, OR USE OF THESE PRODUCTS. In no event shall Seller be liable for consequential, incidental or any other damages of any nature whatsoever except those specifically provided herein for any breach of warranty or any claim arising in any way out of the manufacture, sale, or use of these products. No other person is authorized by Seller to give any other warranty, written or oral, pertaining to the products.

ENGINEERING MANUAL



This engineering manual contains the full AVK product line, application ideas, features and benefits, sales drawings with dimensions and tolerances, material and finish specifications, and technical information on the selection and use of all installation tooling Systems.

PRODUCT INDEX

	PAGE
Welcome to the World of AVK	2
Capabilities	4
Product Introduction	5
Spinwall Technology and Installation Tool Types	5 - 6
Advantages	7
Typical AVK Applications	8-9
AL TM A-L Series Knurled Threaded Insert	10 - 11
AK TM A-K Series Knurled Threaded Insert	12 - 13
AH TM A-H Series Threaded Hex Insert	14 - 15
AR TM A-R Series Threaded Insert	16 - 17
AL TM A-L Series Sealed Head Threaded Insert	18
AH TM A-H Series Sealed Head Threaded Hex Insert	19
AS TM A-S Series Captive Threaded Stud	20 - 21
AT TM A-T Series Knurled Threaded Insert	22 - 23
AW [®] A-W Series Knurled Threaded Insert	24
AO TM A-O Series Threaded Insert	25
RN TM R-N Series Rivet Nut Threaded Insert	26 - 27
E-L TM E-L Metric Series Knurled Threaded Insert	28
E-H TM E-H Metric Series Threaded Hex Insert	28
CS TM New Product Composi-sert TM	29
CL TM New Product Compression Limitor	30
ARO Spin-Spin Pneumatic Tools	31 - 35
Pneumatic Rapid Insert Tool	36
SPP Tool TM Systems - Spin Pull to Pressure	37 - 38
Battery Powered Portable Tools	39 - 40
Hand Tools and Kits	41 - 43
Guidelines for Successful Applications	44
Basic Test Data	45
Dimensional Conversions	46
Plating Chart	47



Get quote »

Angic Global Solutions

1-888-872-0690

<https://www.AngicGlobal.com> Sales@AngicGlobal.com

3



CAPABILITIES



AVK SALES PROFESSIONALS:

AVK's sales representatives and customer service staff are dedicated to assist our customers in providing demonstrations, samples, and technical support. Our global network of Authorized Distributors assist in these efforts and provide for our customer's logistical product needs.



ENGINEERING SUPPORT:

AVK's engineering and installation tool support staff transforms our customers' needs and ideas into robust designs that have become industry standards for innovation and reliability.



MANUFACTURING:

Housed in a 80,000 sq. ft. facility, AVK utilizes state of the art cold forming equipment to produce net shape products at speeds of up to 240 pieces per minute. Secondary customized internal thread rolling, assembly equipment and a "Lean" manufacturing philosophy help to produce products that exceed our customers' expectations from quality and delivery.

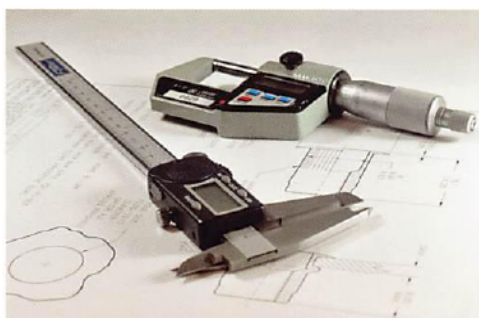

QUALITY:

Our staff of quality experts are dedicated to the principles of ISO/TS16949 and ISO14001. They are continuously working to improve an already world class quality product to even higher levels.

PRODUCT INTRODUCTION



AVK has developed specific manufacturing technology that sets our products apart from other blind installed fastener manufacturers. We call what we do "Spinwall Technology™." AVK's Spinwall Technology™ blind installed fasteners consist of two types. Internally threaded inserts and externally threaded studs. Both products can be installed into a flat, tubular or other shaped materials using hand operated or pneumatic hand held tools right on your assembly line without adjustment even if the parent material varies in thickness. Our products can be installed after paint or other finishes is applied to your product which eliminates the need for thread masking.

INSTALLATION SEQUENCE

Here is how the AVK product is installed "blind."

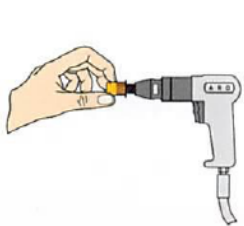

1/4 turn the AVK fastener onto the tool's threaded mandrel.

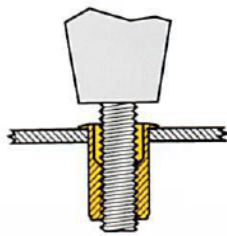

The fastener is placed into the hole.

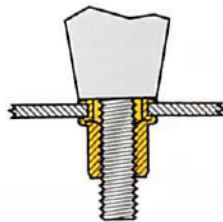

The forward trigger is depressed and the fastener is installed properly.



The reverse trigger is depressed and the tool unthreads from the installed fastener.

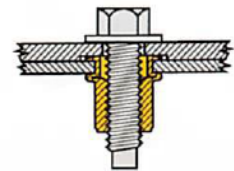

The mating component is then attached using conventional hardware.

SPINWALL TECHNOLOGY™ PRODUCT DESIGN



Round serrated body threaded insert for excellent spin out resistance in drilled or punched holes. Available in steel, aluminum, brass, and monel.



Hex Body threaded insert for punched holes provides exceptional spin out resistance. Available in steel, brass and 302 stainless steel.



Pre-Bulbed slotted body design for exceptional pull out resistance in drilled or punched holes in plastics, composites and thin sheet metal applications. Available in steel.



Round serrated body threaded stud is ideal as a location device to support heavy components before final installation with a mating nut. Available in steel.

SPINWALL TECHNOLOGY™

Spinwall Technology™ ...Sets AVK apart

You will notice throughout this catalog references to the phrase Spinwall Technology™. This phrase describes the philosophy of our product's design, manufacturing and installation systems.

Our Spinwall Technology™ products are manufactured on high-speed, state-of-the-art cold forming equipment on which very precise tolerances are achieved. This capability allows AVK to produce products with unique mechanical and installation properties that result in the AVK product filling the hole prior to backside flange formation. Read more about hole fill and the other advantages of Spinwall Technology™ on the separate product profile pages.

Our Spinwall Technology™ products can be installed using three different types of installation tooling...



Get quote >>

Angic Global Solutions

<https://www.AngicGlobal.com> Sales@AngicGlobal.com

1-888-872-0690

5



INSTALLATION TOOL TYPES



The expendable tool is used for lower consumer cost or field installations.



The lever or plier style tools are used for experimental or field installations.



The pneumatic and battery tool is used for production line work.



Automation system can be used for installations

PUSH TO START - SINGLE ACTION INSTALLATION TOOLS

Single stage trigger for complete thread on and reverse thread off for faster insert installations.



AVK5500



AVK4705



AVK4878



SPP 3 Tool™ Data Master

ARO PNEUMATIC STALL TORQUE TOOL

The ARO pneumatic stall torque type tool installs AVK as follows...



1/4 turn the fastener onto the ARO tool mandrel and place the fastener into the hole.



Depress the top trigger until the tool stalls and the AVK fastener is collapsed.



Depress the lower trigger and the tool unthreads from the installed part.

AVK SPP TOOL™ SYSTEM - SPIN PULL TO PRESSURE

The SPP Tool™ utilizes an ARO pneumatic stall torque tool and incorporates an integrated hydraulic cylinder powered by a remote hydraulic power pack system.



1/4 turn the fastener onto the SPP Tool™ mandrel and place the fastener into the hole.



Depress the tool trigger and the tool spins into the fastener and automatically exerts a pressure controlled pull installing the fastener.



Depress the tool reverse trigger and the tool spins out of the installed fastener.

AUTOMATION



Automation benefits are as follows:

- Labor savings
- Single or multi-simultaneous insert installation
- Maximum up-time providing optimal production output
- Multiple work station configurations are available
- Robotic arm with hole locating vision system is available
- Insert collapse load can be verified

ADVANTAGES OF ASSEMBLY WITH AVK



Here are a few reasons why the use of AVK's blind installed fasteners are **"Improving The Way We Assemble The World™"**

MATERIAL THICKNESS

Material thickness is being reduced to save weight, fuel, pollution and raw material cost. Fastening to thin materials is simple and reliable with AVK. AVK fasteners can be installed into thinner materials with greater ease than can be accomplished with weld nuts, pierce nuts, clinch nuts, thread tapping and thread forming screws.

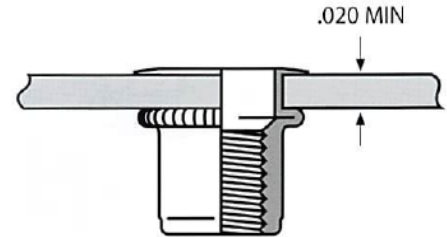

*Minimum grips vary per thread size

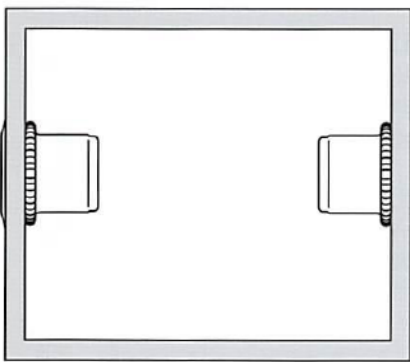

INSTALLS BLIND

New material structures such as hydro formed tubing, aluminum extrusions and composite panels are being specified due to their strength to weight ratios. These materials form blind applications and are ideal for AVK fasteners versus other types of fasteners.

NEAT AND CLEAN

Welding and the attachment of weld fasteners are being replaced with AVK due to health and clean air requirements for workers. The alternatives are expensive capital equipment vacuuming and air scrubber equipment. Weld fasteners also burn away pre-applied galvanized finishes requiring re-work to prevent corrosion. Pre-painted materials cannot be used with weld fasteners as the paint prevents weld nut attachment. Use of pre-painted materials can eliminate painting facility costs and environmental issues. Weld fasteners must be applied before a product is painted. Thread masking procedures are eliminated by the use of AVK as our products can be installed after paint.

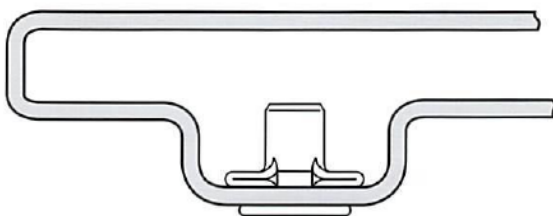

PLASTICS & COMPOSITES

Plastics and composites are being used for products to take advantage of their molding, corrosion resistance, coloring and strength to weight ratios. AVK has specific products for blow, rotational, compression, vacuum, scrimp, honeycomb, processed plastic and composites.

Products designed for consumer assembly to reduce in plant assembly costs use AVK to provide strong threads for the attachment of component parts using conventional hardware.



Get quote >>

Angic Global Solutions

1-888-872-0690

<https://www.AngicGlobal.com> Sales@AngicGlobal.com



TYPICAL AVK APPLICATIONS

E-COAT/PAINTED SHEET METAL

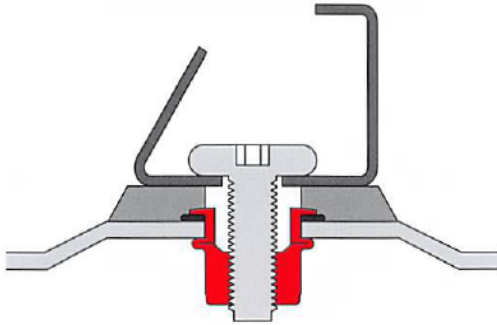

VEHICLE ROOF — LUGGAGE RACK RAIL

FORMED SHEET METAL

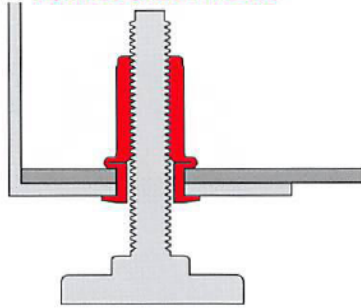

OFFICE FURNITURE — LEG LEVELING

BLOW OR ROTATIONAL MOLDED PLASTICS

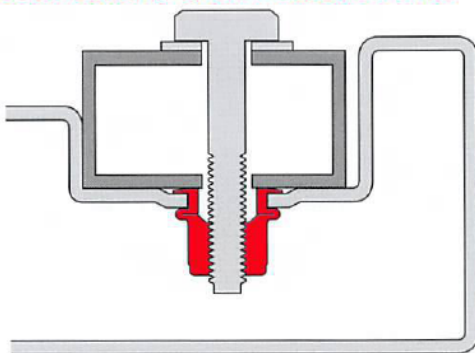

FARM EQUIPMENT — GUARD TO TUBULAR FRAME

HYDROFORMED STEEL TUBING

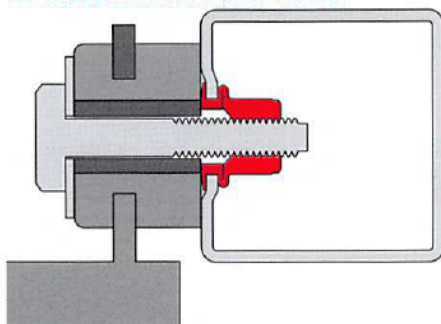

VEHICLE — RADIATOR ATTACHMENT

BLOW MOLDED PLASTIC

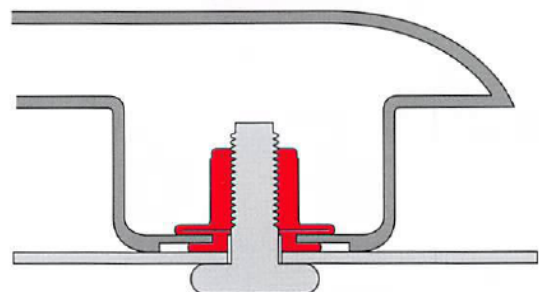

AUTOMOBILES — SPOILER TO TRUNK

● SOLAR PANELS & SYSTEMS

Assembly of solar panel frame extrusions to solar panels • Telescoping tube assembly, and tracking sheet metal enclosures

● MEDICAL EQUIPMENT

Wheelchair Hand Rims • Wheelchair Seats/ Backs
• Handles/Casters to Carts • Components to Hospital Beds • Aluminum Walker Assembly

● MILITARY GROUND SUPPORT

Ducts/Wireways to Shelters • Electronics to Shelters • Missile Container Assembly
• Antenna Assembly • Hardware to Shelters

● MILITARY VEHICLES

Side Mirrors to Body • Armor to Body
• Bulletproof Glass to Body • Instruments to Dash • Cargo Hold Down to Floor Pan

● OFFICE FURNITURE

Modular Unit Stacking • Hardware/Hinges to Unit • Leg Leveling • Knock-Down Assembly • Partition Electrical Components

● RECREATION

Playground Equipment Assembly • Bicycle Frame Water Bottle Attachment • Basketball Pole Assembly • Golf Cart Roof Supports to Body • Consumer Assembly of Toys

● REFRIGERATION

Hinges to Doors/Cabinet • Handles to Doors • Shelf Brackets to Wall • Compressor to Base Pan • Leg Leveling

● RV INDUSTRY

Instruments to Boat Dash • Bow Rails to Deck • Components to Snowmobile • Components to Motorcycles • RV Awning Assembly

● TRUCKS/TRAILERS

Mirrors/Lights to Cab • Grab Handles to Cab • Firewall Attachments • Instruments to Dash • Exhaust/Wind Deflectors

TYPICAL AVK APPLICATIONS



● AEROSPACE

Galley Equipment Casters to Frame • Aircraft Seating Footrests to Frame • Aircraft Seat Trays to Frame • Bulkhead Partition Mounting Brackets • Shipping Container Hinges and Latches to Frame

● APPLIANCES

Refrigerator Hinge to Cabinet • Refrigerator Handle to Door • Leg Leveler • Components to Cabinet • Under the Counter Attachments

● ARCHITECTURAL

Vinyl Window Hardware to Frame • Aluminum Door Hardware to Frame • Threshold Sweeps to Frame • Aluminum Railing "T" Joints • Patio Enclosure Construction

● AUTO/SPORT-UTILITY VEHICLES

Luggage Racks to Roof • Spoilers to Trunk Lids • Option Controls to Dash Panel • Under Hood Option Items • Grab Handles • Air Bag Attachments

● ELECTRONICS CABINetry

Hardware to Cabinet • Hinges to Cabinet • Leg Levelers • Components to Frame • Lifting Anchors

● EXERCISE EQUIPMENT

Stationary Bike Floor Supports to Frame • Treadmill Controls to Frame • Sheet Metal Covers over Motors • Weightlifting Frame Assembly • Electronics to Unit

● LAWN/GARDEN FARM IMPLEMENT

Mirrors/Lights to Cab • Components to Decking • Guards to Framing • Seats to Framing • Access Panels to Frame

● FURNITURE

Aluminum Furniture Assembly • Leg Leveling • Brass Headboards to Frame • Patio Table Assembly • Tubular Bed Frame Assembly

● HEATING/AIR CONDITIONING

Compressors to Base Pans • Access Doors to Cabinet • Motors to Blower Housing • Blower Housing to Unit • Burner Assembly to Unit

ALUMINUM EXTRUSIONS

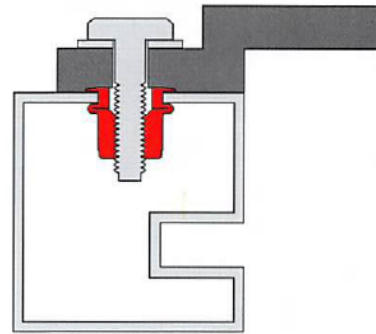

ENTRY DOORS — PUSH BARS TO DOOR FRAME

POWDER COATED STEEL TUBE

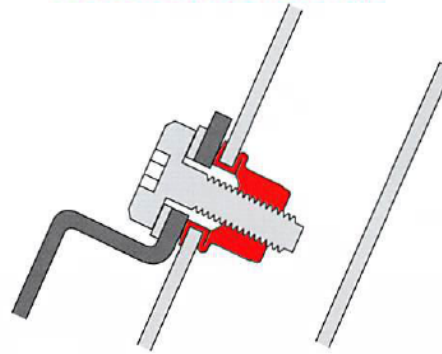

BICYCLE FRAME — WATER BOTTLE BRACKET

PREPAINTED FOAM CORE SHEET METAL

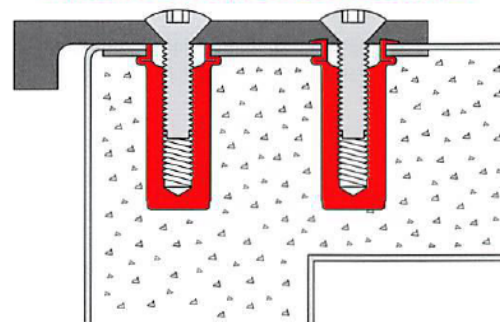

REFRIGERATION EQUIPMENT — HINGES TO CABINET

E-COAT/PAINTED SHEET METAL

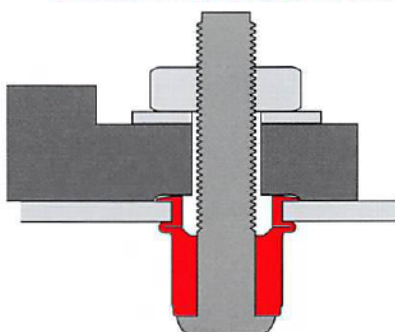

VEHICLE DASH PANEL — ABS MODULE MOUNTING

GALVANIZED SHEET METAL

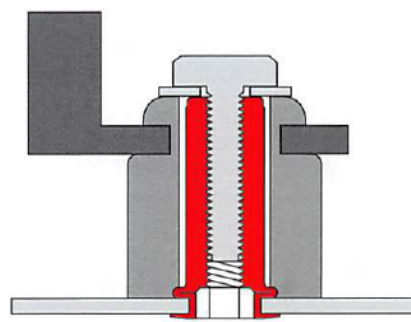

AIR CONDITIONER BASE PAN — COMPRESSOR MOUNTING



Get quote >>

Angic Global Solutions

1-888-872-0690

9

<https://www.AngicGlobal.com> Sales@AngicGlobal.com



A-L SERIES INSERT PROFILE

The **A-L Series Insert** features a knurled body and large diameter—low profile head making it ideal for use in punched or drilled holes. The Steel A-L Series Insert offers the highest all around strength characteristics and has been designed to be used with Grade 5 or Metric 8.8/9.8 mating screws. The A-L Series is AVK's most versatile performer.

The A-L Series Insert can be installed using AVK's ARO brand pneumatic tools or AVK's SPP Tool™ System pneumatic/hydraulic tooling. These tools can be located at any position on your assembly line. The A-L Series can be installed either before or after finish.



As the A-L Series is installed, the knurled body expands 360° **FILLING THE HOLE**. This feature provides exceptional torque strength and vibration resistance.

SPINWALL TECHNOLOGY™

HOW HOLE FILL WORKS FOR YOU

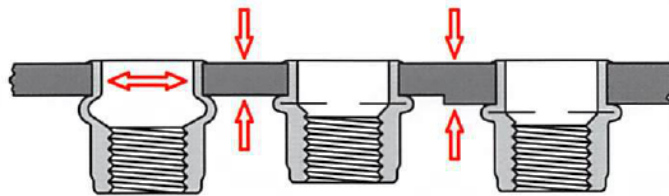

The installation tool then continues to install the insert forming a backside flange even in multiple or variable thickness materials **WITHOUT ADJUSTMENT**.

DESIGN BENEFITS

- **EXCEPTIONAL TORQUE STRENGTH** is achieved as the insert's knurled body expands **FILLING THE HOLE**.
- **QUALITY INSTALLATIONS** even in variable thickness materials are assured by AVK's spin/spin ARO pneumatic tools and our pneumatic hydraulic SPP Tool™ Systems.
- **SUPERIOR THREAD STRENGTH** is provided due to our internal rolled thread manufacturing process.
- **THREADS GAUGE** before and after installation due to the increased cross-sectional thickness of the thread area. Thread dilation is prevented.
- **INVENTORY REDUCTION** is possible because of the A-L Series' wide grip range capacity. It is 2.5 times greater than conventional rivet nuts.
- **SUPERIOR CORROSION RESISTANCE** is provided by our standard zinc/yellow trivalent finish (120 hours. salt spray to white corrosion). For exceptional corrosion protection we offer a trivalent tin/zinc alloy finish.
- **AVAILABLE** in steel. Additional materials such as aluminum, brass and monel are available by special order. Contact an AVK Sales Representatives.

ADDITIONAL DESIGN TYPES

ORIGINAL CLOSED END

Thread area is enclosed eliminating leakage past the threads from either side of the application. See page 11.



LIGHT CLOSED END

Offers the same benefits as the original with 5-30% weight savings



SEALED HEAD

A PVC foam seal is bonded to the underside of the head and when installed provides a weather tight seal. (Also available in the closed end version.) See page 18 for important grip information.



WEDGE HEAD

The addition of wedges under the head provides even greater torque capability, especially in soft or thin materials and is excellent for electrical grounding applications. Contact an AVK Sales Representative for details.



UNIFIED (INCH) AND METRIC THREAD SIZES



INSERT
KNURLED THREADED INSERTS

OPEN END TYPE

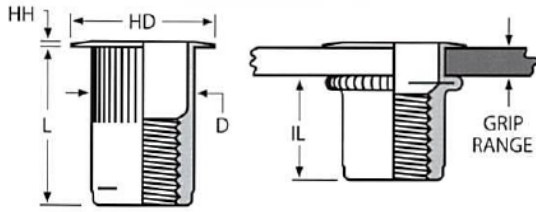

CLOSED END TYPE

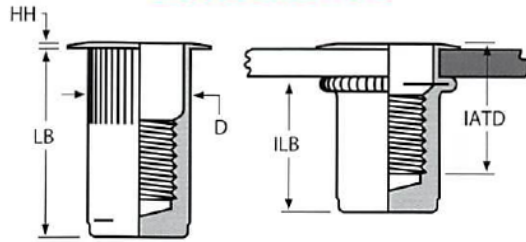

Thread Specifications: Unified 2B/21 per ASME B1.1
Metric 6H/21 per ASME B1.13M

THREAD SIZE	THREAD CALL OUT	GRIP RANGE	GRIP CALL OUT	HOLE SIZE +.006 / -.000	HD ±.010 ±.025*	HH ±.003	L ±.015	D MAX.	IL MAX.	LB MAX.	ILB MAX.	IATD** MAX.
6-32 UNC	632	.020 - .080	80	17/64 (.2656)	.390	.030	.420	.265	.305	.755	.640	.610
6-32 UNC	632	.080 - .130	130	17/64 (.2656)	.390	.030	.470	.265	.305	.755	.580	.670
8-32 UNC	832	.020 - .080	80	17/64 (.2656)	.390	.030	.420	.265	.305	.755	.640	.610
8-32 UNC	832	.080 - .130	130	17/64 (.2656)	.390	.030	.470	.265	.305	.755	.580	.670
10-24 UNC	1024	.020 - .130	130	19/64 (.2969)	.415	.030	.475	.296	.315	1.005	.845	.730
10-24 UNC	1024	.130 - .225	225	19/64 (.2969)	.415	.030	.585	.296	.315	1.005	.735	.840
10-32 UNF	1032	.020 - .130	130	19/64 (.2969)	.415	.030	.475	.296	.315	1.005	.845	.730
10-32 UNF	1032	.130 - .225	225	19/64 (.2969)	.415	.030	.585	.296	.315	1.005	.735	.840
1/4-20 UNC	420	.027 - .165	165	25/64 (.3906)	.500	.030	.580	.390	.380	1.205	1.005	.895
1/4-20 UNC	420	.165 - .260	260	25/64 (.3906)	.500	.030	.680	.390	.380	1.205	.905	1.035
5/16-18 UNC	518	.027 - .150	150	17/32 (.5312)	.685*	.035	.690	.530	.470	1.405	1.175	.995
5/16-18 UNC	518	.150 - .312	312	17/32 (.5312)	.685*	.035	.805	.530	.425	1.405	1.025	1.120
3/8-16 UNC	616	.027 - .150	150	17/32 (.5312)	.685*	.035	.690	.530	.470	1.405	1.175	.995
3/8-16 UNC	616	.150 - .312	312	17/32 (.5312)	.685*	.035	.805	.530	.425	1.405	1.025	1.120
1/2-13 UNC	813	.063 - .200	200	11/16 (.6875)	.865*	.047	1.150	.685	.850	2.380	2.070	1.505
1/2-13 UNC	813	.200 - .350	350	11/16 (.6875)	.865*	.047	1.300	.685	.850	2.380	1.920	1.505
1/2-13 UNC	813	.350 - .500	500	11/16 (.6875)	.865*	.047	1.450	.685	.860	2.380	1.770	1.505

THREAD SIZE	THREAD CALL OUT	GRIP RANGE	GRIP CALL OUT	HOLE SIZE +.015 / -.000	HD ±0.25 ±0.64*	HH ±0.08	L ±0.38	D MAX.	IL MAX.	LB MAX.	ILB MAX.	IATD** MAX.
M4 x 0,7 ISO	470	0,50 - 2,00	2.0	6,75	9,91	0,76	10,67	6,73	7,75	19,18	16,26	15,49
M4 x 0,7 ISO	470	2,00 - 3,30	3.3	6,75	9,91	0,76	11,94	6,73	7,75	19,18	14,73	17,02
M5 x 0,8 ISO	580	0,50 - 3,30	3.3	7,60	10,54	0,76	12,07	7,52	8,00	25,53	21,46	18,54
M5 x 0,8 ISO	580	3,30 - 5,70	5.7	7,60	10,54	0,76	14,86	7,52	8,00	25,53	18,67	21,34
M6 x 1,0 ISO	610	0,70 - 4,20	4.2	10,00	12,70	0,76	14,73	9,91	9,65	30,61	25,53	22,73
M6 x 1,0 ISO	610	4,20 - 6,60	6.6	10,00	12,70	0,76	17,27	9,91	9,65	30,61	22,99	26,29
M8 x 1,25 ISO	8125	0,70 - 3,80	3.8	13,50	17,40*	0,89	17,53	13,46	11,94	35,69	29,85	25,27
M8 x 1,25 ISO	8125	3,80 - 7,90	7.9	13,50	17,40*	0,89	20,45	13,46	10,80	35,69	26,04	28,45
M10 x 1,5 ISO	1015	0,70 - 3,80	3.8	13,50	17,40*	0,89	17,53	13,46	11,94	35,69	29,85	25,27
M10 x 1,5 ISO	1015	3,80 - 7,90	7.9	13,50	17,40*	0,89	20,45	13,46	10,80	35,69	26,04	28,45
M12 x 1,75 ISO	12175	1,60 - 5,10	5.1	17,45	21,97*	1,19	29,21	17,4	21,59	60,45	52,58	38,23
M12 x 1,75 ISO	12175	5,10 - 8,90	8.9	17,45	21,97*	1,19	33,02	17,4	21,59	60,45	48,77	38,23
M12 x 1,75 ISO	12175	8,90 - 12,7	12.7	17,45	21,97*	1,19	36,83	17,4	21,84	60,45	44,96	38,23

NOTE 1: Grip range can be affected by parent material density and actual hole size. AVK suggests trial installations to determine optimum grip.

NOTE 2: Additional UNF fine threads are available. Contact an AVK Sales Representative for details.

NOTE 3: Additional grip lengths are available. Contact an AVK Sales Representative for details. **Dimensions in minimum grip condition.

***NOTE 4: Closed End CRES inserts have a reduced "LB" and "ILB" dimension. Contact an AVK sales rep for details.

PART NUMBERING SYSTEM



SAMPLE NUMBER: ALS3T-420-165

AL	()	()	-()	-()	()
PRODUCT SERIES	MATERIAL	FINISH RoHS COMPLIANT	THREAD CALL OUT	GRIP CALL OUT	TYPE
CALL OUT	GRADE	CALL OUT	SPECIFICATION	CALL OUT	TYPE
S	Steel 1010/1008	3T	ZINC TRIVALENT PER ASTM-B-633, FE/ZN .0003 (8µ) WITH CLEAR PROTECTIVE COATING	BLANK	Open End
A	Aluminum 5056	4T	YELLOW ZINC TRIVALENT PER ASTM-B-633, FE/ZN .0003 (8µ) WITH CLEAR PROTECTIVE COATING	B	Closed End
B	Brass 270/260	9T	TIN ZINC TRIVALENT PER ESP-P-004, .0003 (8µ) WITH CLEAR PROTECTIVE COATING	S	Sealed (See Pg.18)
M	Monel 400	Note: For Additional Plating See Chart on Page 47		W	Wedge Head
C	CRES 302***				



Get quote >>

Angic Global Solutions

<https://www.AngicGlobal.com> Sales@AngicGlobal.com

1-888-872-0690

11



A-K SERIES INSERT PROFILE

The **A-K Series** Insert features a knurled body and a reduced profile head to allow for virtually flush installation. Countersink drilling or dimpling of the parent material can be eliminated. The Steel A-K Series is designed to be used with Grade 5 or Metric Class 8.8/9.8 mating screws.

The A-K Series Insert can be installed using AVK's ARO brand pneumatic tools or AVK's SPP™ pneumatic/hydraulic tooling. These tools can be located at any position on your assembly line. The A-K Series Insert can be installed either before or after finish.



SPINWALL TECHNOLOGY™

HOW HOLE FILL WORKS FOR YOU

As the A-K Series is installed, the knurled body expands 360° **FILLING THE HOLE**. This feature provides exceptional torque strength and vibration resistance.

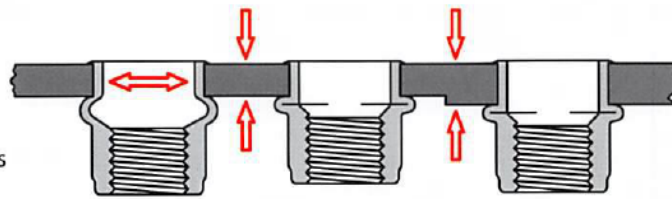

The installation tool then continues to install the insert forming a backside flange even in multiple or variable thickness materials **WITHOUT ADJUSTMENT**.

DESIGN BENEFITS

- **VIRTUALLY FLUSH INSTALLATIONS** are achieved without special hole preparation due to the A-K Series minimal head profile.
- **EXCEPTIONAL TORQUE STRENGTH** is achieved as the insert's knurled body expands **FILLING THE HOLE**.
- **QUALITY INSTALLATIONS** even in variable thickness materials are assured by AVK's spin/spin ARO pneumatic tools and our pneumatic/hydraulic SPP Tool™ Systems.
- **SUPERIOR THREAD STRENGTH** is provided due to our internal rolled thread manufacturing process.
- **THREADS GAUGE** before and after installation due to the increased cross-sectional thickness of the thread area. Thread dilation is prevented.
- **INVENTORY REDUCTION** is possible because of the A-K Series' wide grip range capacity. It is 2.5 times greater than conventional rivet nuts.
- **SUPERIOR CORROSION RESISTANCE** is provided by our standard zinc/yellow trivalent finish (120 hours. Salt spray to white corrosion). For exceptional corrosion protection we offer a trivalent tin/zinc alloy finish.
- **AVAILABLE** in steel. Additional materials such as aluminum, brass and monel are available by special order. Contact an AVK Sales Representative for details.

ADDITIONAL DESIGN TYPES

ORIGINAL CLOSED END

Thread area is enclosed eliminating leakage past the threads from either side of the application. See page 13.



LIGHT CLOSED END

Offers the same benefits as the original with a 5 – 30% weight savings.



UNIFIED (INCH) AND METRIC THREAD SIZES



INSERT
KNURLED THREADED INSERTS

OPEN END TYPE

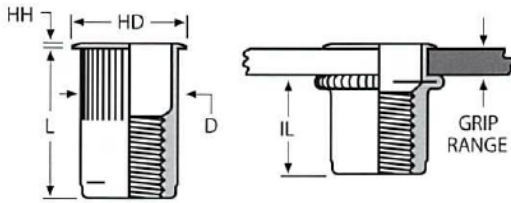

CLOSED END TYPE

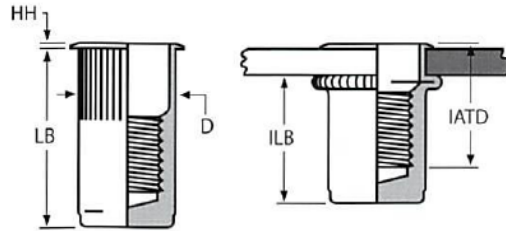

Thread Specifications: Unified 2B/21 per ASME B1.1
Metric 6H/21 per ASME B1.13M

THREAD SIZE	THREAD CALL OUT	GRIP RANGE	GRIP CALL OUT	HOLE SIZE +.006 / -.000	HD ±.015	HH ±.003	L ±.015	D MAX.	IL MAX.	LB MAX.	ILB MAX.	IATD* MAX.
6-32 UNC	632	.020 - .080	80	17/64 (.2656)	.310	.019	.420	.265	.305	.755	.640	.610
6-32 UNC	632	.080 - .130	130	17/64 (.2656)	.310	.019	.470	.265	.305	.755	.580	.670
8-32 UNC	832	.020 - .080	80	17/64 (.2656)	.310	.019	.420	.265	.305	.755	.640	.610
8-32 UNC	832	.080 - .130	130	17/64 (.2656)	.310	.019	.470	.265	.305	.755	.580	.670
10-24 UNC	1024	.020 - .130	130	19/64 (.2969)	.340	.019	.475	.296	.315	1.005	.845	.730
10-24 UNC	1024	.130 - .225	225	19/64 (.2969)	.340	.019	.585	.296	.315	1.005	.735	.840
10-32 UNF	1032	.020 - .130	130	19/64 (.2969)	.340	.019	.475	.296	.315	1.005	.845	.730
10-32 UNF	1032	.130 - .225	225	19/64 (.2969)	.340	.019	.585	.296	.315	1.005	.735	.840
1/4-20 UNC	420	.027 - .165	165	25/64 (.3906)	.455	.023	.580	.390	.380	1.205	1.005	.895
1/4-20 UNC	420	.165 - .260	260	25/64 (.3906)	.455	.023	.680	.390	.380	1.205	.905	1.035
5/16-18 UNC	518	.027 - .150	150	17/32 (.5312)	.595	.023	.690	.530	.470	1.405	1.175	.995
5/16-18 UNC	518	.150 - .312	312	17/32 (.5312)	.595	.023	.805	.530	.425	1.405	1.025	1.120
3/8-16 UNC	616	.027 - .150	150	17/32 (.5312)	.595	.023	.690	.530	.470	1.405	1.175	.995
3/8-16 UNC	616	.150 - .312	312	17/32 (.5312)	.595	.023	.805	.530	.425	1.405	1.025	1.120

THREAD SIZE	THREAD CALL OUT	GRIP RANGE	GRIP CALL OUT	HOLE SIZE +.015 / -.000	HD ±.038	HH ±.008	L ±.038	D MAX.	IL MAX.	LB MAX.	ILB MAX.	IATD* MAX.
M4 x 0,7 ISO	470	0,50 - 2,00	2.0	6,75	7,87	0,48	10,67	6,73	7,75	19,18	16,26	15,49
M4 x 0,7 ISO	470	2,00 - 3,30	3.3	6,75	7,87	0,48	11,94	6,73	7,75	19,18	14,73	17,02
M5 x 0,8 ISO	580	0,50 - 3,30	3.3	7,60	8,64	0,48	12,07	7,52	8,00	25,53	21,46	18,54
M5 x 0,8 ISO	580	3,30 - 5,70	5.7	7,60	8,64	0,48	14,86	7,52	8,00	25,53	18,67	21,34
M6 x 1,0 ISO	610	0,70 - 4,20	4.2	10,00	11,56	0,58	14,73	9,91	9,65	30,61	25,53	22,73
M6 x 1,0 ISO	610	4,20 - 6,60	6.6	10,00	11,56	0,58	17,27	9,91	9,65	30,61	22,99	26,29
M8 x 1,25 ISO	8125	0,70 - 3,80	3.8	13,50	15,11	0,58	17,53	13,46	11,94	35,69	29,85	25,27
M8 x 1,25 ISO	8125	3,80 - 7,90	7.9	13,50	15,11	0,58	20,45	13,46	10,80	35,69	26,04	28,45
M10 x 1,5 ISO	1015	0,70 - 3,80	3.8	13,50	15,11	0,58	17,53	13,46	11,94	35,69	29,85	25,27
M10 x 1,5 ISO	1015	3,80 - 7,90	7.9	13,50	15,11	0,58	20,45	13,46	10,80	35,69	26,04	28,45

NOTE 1: Grip range can be affected by parent material density and actual hole size. AVK suggests trial installations to determine optimum grip.

NOTE 2: Additional UNF fine threads are available. Contact an AVK Sales Representative for details.

NOTE 3: Additional grip lengths are available. Contact an AVK Sales Representative for details. *Dimensions in minimum grip condition.

NOTE 4: Contact an AVK Sales Representative regarding optional materials.

PART NUMBERING SYSTEM



SAMPLE NUMBER: AKS3T-420-165

AK	()	()	-()	-()	()	
PRODUCT SERIES	MATERIAL	FINISH ROHS COMPLIANT	THREAD CALL OUT	GRIP CALL OUT	TYPE	
CALL OUT	GRADE	CALL OUT	SPECIFICATION		CALL OUT	TYPE
S	Steel 1010/1008	3T	ZINC TRIVALENT PER ASTM-B-633, FE/ZN .0003 (8µ) WITH CLEAR PROTECTIVE COATING		BLANK	Open End
A	Aluminum 5056	4T	YELLOW ZINC TRIVALENT PER ASTM-B-633, FE/ZN .0003 (8µ) WITH CLEAR PROTECTIVE COATING		B	Closed End
B	Brass 270/260	9T	TIN ZINC TRIVALENT PER ESP-P-004, .0003 (8µ) WITH CLEAR PROTECTIVE COATING			
M	Monel 400		Note: For Additional Plating See Chart on Page 47			



Get quote >>

Angic Global Solutions

<https://www.AngicGlobal.com> Sales@AngicGlobal.com

1-888-872-0690

13



A-H SERIES INSERT PROFILE

The **A-H Series Insert** features a radius corner hex body. When installed into a corresponding hex hole, the radius corners of the A-H Series Insert expand and fill the hole corners providing exceptional resistance to spinning in the panel. The Steel A-H Series is designed to be used with Grade 5 or Metric Class 8.8/9.8 mating screws.

The A-H Series Insert can be installed using AVK's ARO brand pneumatic tools or AVK's SPP™ pneumatic/hydraulic tooling systems. These tools can be located at any position on your assembly line. The A-H Series Insert can be installed either before or after finish.



SPINWALL TECHNOLOGY™

HOW HOLE FILL WORKS FOR YOU

As the A-H Series is installed, the radius cornered hex body expands **FILLING THE HOLE**. This feature provides exceptional torque strength and vibration resistance.

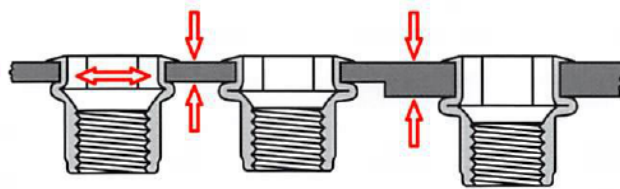

The installation tool then continues to install the insert forming a backside flange even in multiple or variable thickness materials **WITHOUT ADJUSTMENT**.

DESIGN BENEFITS

- EXCEPTIONAL resistance to spinning in the panel is achieved as the A-H Series' hex body expands **FILLING THE HOLE**.
- **AVOID STRESS FRACTURES** of your material and prolong punch and die life by specifying a radius corner in your hex hole. This is possible when using the A-H Series radius hex body insert.
- **QUALITY INSTALLATIONS** even in variable thickness materials are assured by AVK's spin/spin ARO pneumatic tools and our pneumatic/hydraulic SPP Tool™ Systems.
- **SUPERIOR THREAD STRENGTH** is provided due to our internal rolled thread manufacturing process.
- **THREADS GAUGE** before and after installation due to the increased cross-sectional thickness of the thread area. Thread dilation is prevented.
- **INVENTORY REDUCTION** is possible because of the A-H Series' wide grip range capacity. It is 2.5 times greater than conventional rivet nuts.
- **SUPERIOR CORROSION RESISTANCE** is provided by our standard zinc/yellow trivalent finish (120 hours. salt spray to white corrosion). For exceptional corrosion protection we offer a trivalent tin/zinc alloy finish.
- **AVAILABLE** in steel. Additional materials such as aluminum, brass and monel are available by special order. Contact an AVK Sales Representative.

ADDITIONAL DESIGN TYPES

ORIGINAL CLOSED END

Thread area is enclosed eliminating leakage past the threads from either side of the application. See page 15.



LIGHT CLOSED END

Offers the same benefits as the original with a 5-30% weight savings.



SEALED HEAD

A PVC foam seal is bonded to the underside of the head and when installed provides a weather tight seal. (Also available in the closed end version.) See page 19 for important grip information.



OPEN END

Stainless Steel Hex body insert available in specific thread ranges only. Please contact an AVK Sales Representative for more information.



UNIFIED (INCH) AND METRIC THREAD SIZES



INSERT
THREADED HEX INSERT

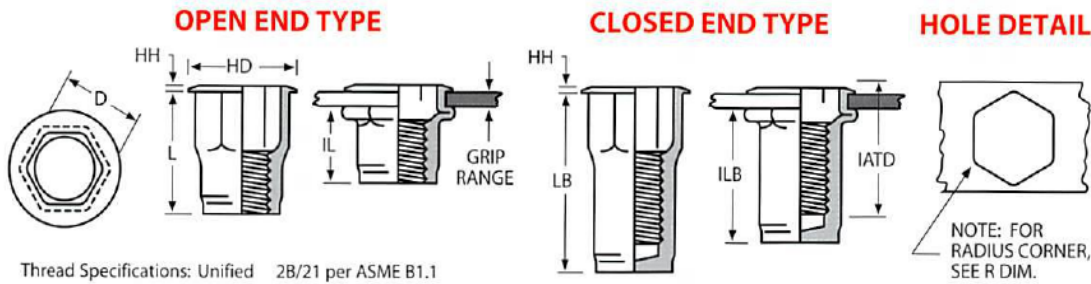

Thread Specifications: Unified 2B/21 per ASME B1.1
Metric 6H/21 per ASME B1.13M

NOTE: FOR RADIUS CORNER, SEE R DIM.

THREAD SIZE	THREAD CALL OUT	GRIP RANGE	GRIP CALL OUT	HOLE SIZE (ACROSS FLATS) +.004 / -.000	HD ±.010 ±.025*	HH ±.003	L ±.015	D MAX.	IL MAX.	LB MAX.	ILB MAX.	IATD** MAX.	R MAX.
6-32 UNC	632	.020 - .080	80	.250	.375	.027	.385	.249	.295	.755	.640	.575	.015
6-32 UNF	632	.080 - .130	130	.250	.375	.027	.435	.249	.295	.755	.580	.640	.015
8-32 UNC	832	.020 - .080	80	.250	.375	.027	.385	.249	.295	.755	.640	.575	.015
8-32 UNF	832	.080 - .130	130	.250	.375	.027	.435	.249	.295	.755	.580	.640	.015
10-24 UNC	1024	.020 - .130	130	.281	.390	.027	.435	.280	.275	1.045	.845	.695	.020
10-24 UNF	1024	.130 - .225	225	.281	.390	.027	.535	.280	.275	1.045	.735	.805	.020
10-32 UNF	1032	.020 - .130	130	.281	.390	.027	.435	.280	.275	1.045	.845	.695	.020
10-32 UNF	1032	.130 - .225	225	.281	.390	.027	.535	.280	.275	1.045	.735	.805	.020
1/4-20 UNC	420	.027 - .165	165	.375	.510	.030	.585	.374	.400	1.205	1.015	.945	.040
1/4-20 UNF	420	.165 - .260	260	.375	.510	.030	.685	.374	.400	1.205	.915	1.085	.040
5/16-18 UNC	518	.027 - .150	150	.500	.655*	.035	.685	.499	.530	1.460	1.235	1.045	.040
5/16-18 UNF	518	.150 - .312	312	.500	.655*	.035	.845	.499	.515	1.460	1.220	1.170	.040
3/8-16 UNC	616	.027 - .150	150	.500	.655*	.035	.685	.499	.530	1.460	1.235	1.045	.040
3/8-16 UNF	616	.150 - .312	312	.500	.655*	.035	.845	.499	.515	1.460	1.220	1.170	.040
1/2-13 UNC	813	.063 - .200	200	.687	.865*	.047	1.150	.686	.850	2.380	2.070	1.505	.040
1/2-13 UNF	813	.200 - .350	350	.687	.865*	.047	1.300	.686	.850	2.380	1.920	1.505	.040
1/2-13 UNF	813	.350 - .500	500	.687	.865*	.047	1.450	.686	.860	2.380	1.770	1.505	.040

THREAD SIZE	THREAD CALL OUT	GRIP RANGE	GRIP CALL OUT	HOLE SIZE (ACROSS FLATS) +0,10 / -0,00	HD ±0,25 ±0,64*	HH ±0,08	L ±0,38	D MAX.	IL MAX.	LB MAX.	ILB MAX.	IATD** MAX.	R MAX.
M4 x 0,7 ISO	470	0,50 - 2,00	2,0	6,35	9,53	0,68	9,78	6,35	7,49	19,18	16,26	14,61	0,38
M4 x 0,7 ISO	470	2,00 - 3,30	3,3	6,35	9,53	0,68	11,05	6,35	7,49	19,18	14,73	16,26	0,38
M5 x 0,8 ISO	580	0,50 - 3,30	3,3	7,14	9,91	0,68	11,05	7,10	6,99	26,54	21,46	17,65	0,50
M5 x 0,8 ISO	580	3,30 - 5,70	5,7	7,14	9,91	0,68	13,59	7,10	6,99	26,54	18,67	20,45	0,50
M6 x 1,0 ISO	610	0,70 - 4,20	4,2	9,53	12,96	0,76	14,86	9,50	10,16	30,61	25,78	24,00	1,00
M6 x 1,0 ISO	610	4,20 - 6,60	6,6	9,53	12,96	0,76	17,40	9,50	10,16	30,61	23,24	27,56	1,00
M8 x 1,25 ISO	8125	0,70 - 3,80	3,8	12,70	16,64*	0,89	17,40	12,70	13,46	37,08	31,37	26,54	1,00
M8 x 1,25 ISO	8125	3,80 - 7,90	7,9	12,70	16,64*	0,89	21,46	12,70	13,08	37,08	30,99	29,72	1,00
M10 x 1,5 ISO	1015	0,70 - 3,80	3,8	12,70	16,64*	0,89	17,40	12,70	13,46	37,08	31,37	26,54	1,00
M10 x 1,5 ISO	1015	3,80 - 7,90	7,9	12,70	16,64*	0,89	21,46	12,70	13,08	37,08	30,99	29,72	1,00
M12 x 1,75 ISO	12175	1,60 - 5,10	5,1	17,45	21,97*	1,19	29,21	17,42	21,59	60,45	52,58	38,23	1,00
M12 x 1,75 ISO	12175	5,10 - 8,90	8,9	17,45	21,97*	1,19	33,02	17,42	21,59	60,45	48,77	38,23	1,00
M12 x 1,75 ISO	12175	8,90 - 12,7	12,7	17,45	21,97*	1,19	36,83	17,42	21,84	60,45	44,96	38,23	1,00

NOTE 1: Grip range can be affected by parent material density and actual hole size. AVK suggests trial installations to determine optimum grip.

NOTE 2: Additional UNF fine threads are available. Contact an AVK Sales Representative for details

NOTE 3: Additional grip lengths are available in certain thread sizes. Contact an AVK Sales Representative for details. **Dimensions in minimum grip condition.

***NOTE 4: Closed End CRES inserts have a reduced "LB" and "ILB" dimension. Contact an AVK sales rep for details.

PART NUMBERING SYSTEM



SAMPLE NUMBER: AHS3T-420-165

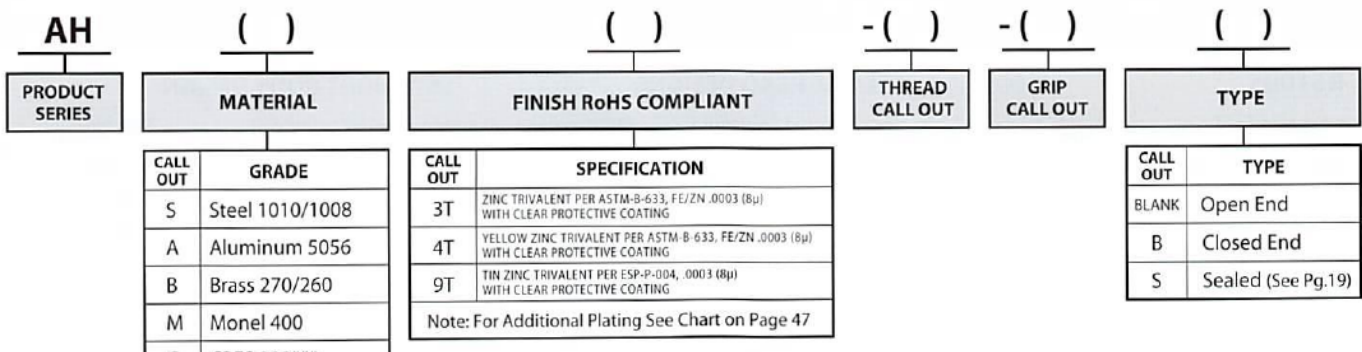

Get quote >>

Section on page 3

Angic Global Solutions

<https://www.AngicGlobal.com> Sales@AngicGlobal.com

1-888-872-0690

15



A-R SERIES INSERT PROFILE

The **A-R Series** threaded insert has been designed for use in plastics and thin gauge sheet metal applications where increased pull-out resistance is required.

The A-R Series features a PreSet™ slotted body design that when installed folds into four segments gripping the backside of the parent material. This design feature allows the A-R Series to be installed into single, variable or multiple thickness materials using AVK's ARO torque-stall pneumatic tools or AVK's pneumatic/hydraulic SPP Tool™ Systems.



A-R Series PreSet™ Design

How it works for you: The PreSet slightly expanded slotted body design of the A-R Series enables it to be installed using torque type tools.

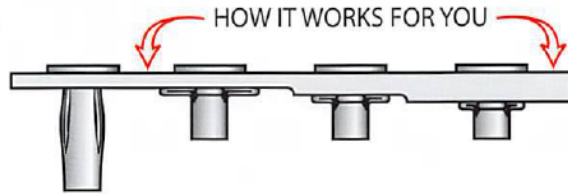

Hand or pneumatic torque tools will install the A-R Series in single, variable or multiple thickness.

DESIGN BENEFITS

- **INSTALLS USING TORQUE** stall type tooling due to the slightly expanded slotted body design. This is important when working with plastics that vary in thickness. No adjustment of the tool is necessary when installing the part into variable thickness materials.
- **INSTALLS USING HAND WRENCHED TORQUE** type tools. Ideal for use in kits and consumer installation applications.
- **PROVIDES EXCEPTIONAL** pull out resistance in soft plastics or thin sheet metal applications even if holes are hand drilled and oversized.
- **SUPERIOR CORROSION RESISTANCE** because all surfaces of the slotted body are plated. Standard plating is zinc/yellow trivalent finish (120 hours to white corrosion). For exceptional corrosion protection we offer a trivalent tin/zinc alloy finish.
- Superior thread strength due to AVK's internal roll threading process.
- **AVAILABLE IN STEEL.**

AIR TOOL SELECTION - SPP TOOL™

The A-R Series has been designed to install with either the SPP Tool™ Systems or the ARO type tool. The SPP Tool™ Systems will install the A-R Series per the suggested grip ranges shown on page 17. See page 36 and 37 for SPP Tool™ Systems information.

AIR TOOL SELECTION - ARO TOOL

The ARO pneumatic tool shown on page 35 will install the A-R Series threaded insert. It will affect the published grip range of the part based on the tools' RPM and the density of the parent material. See the chart on page 17 for grip range information. AVK suggests trial installations in the actual application before specifying the optimum ARO tool.

ADDITIONAL DESIGN TYPES

A-R STUDS

An A-R blind side, petaled footprint produces exceptional pull-out combined with a stud for component attachment. Contact an AVK Sales Representative for availability.



SPECIAL HEAD DESIGNS

Special head configurations such as square or wedge head can increase the inserts holding resistance in the parent material. Contact an AVK Sales Representative for availability.



STRAIGHT BODY DESIGN

A straight body A-R Series insert is ideal for thin sheet metals, tubing & plastic applications where high pull-out is required. Contact an AVK Sales Representative for availability.



UNIFIED (INCH) AND METRIC THREAD SIZES

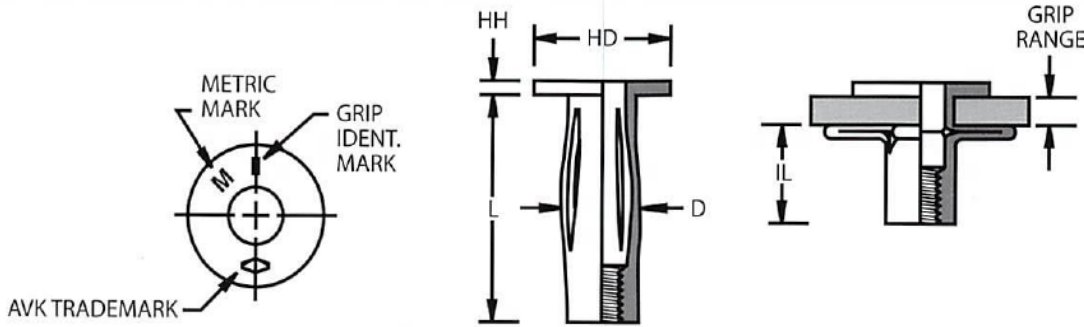

Thread Specifications: Unified 2B/21 per ASME B1.1
Metric 6H/21 per ASME B1.13M

THREAD SIZE	THREAD CALL OUT	GRIP RANGE	GRIP CALL OUT	HOLE SIZE	HD	HH	L	D MAX.	IL MAX.	GRIP ID MARK
1/4-20 UNC	420	.020 - .280	.280	.396 .390	.645 .610	.063 .053	1.015 .985	.382	.520	Blank
1/4-20 UNC	420	.280 - .500	.500	.396 .390	.645 .610	.063 .053	1.249 1.219	.382	.520	1 Rad
5/16-18 UNC	518	.020 - .280	.280	.506 .500	.770 .740	.067 .057	1.156 1.126	.495	.775	Blank
5/16-18 UNC	518	.280 - .500	.500	.506 .500	.770 .740	.067 .057	1.390 1.360	.495	.775	1 Rad
3/8-16 UNC	616	.020 - .280	.280	.600 .594	.895 .865	.093 .083	1.233 1.205	.587	.775	Blank
3/8-16 UNC	616	.280 - .500	.500	.600 .594	.895 .865	.093 .083	1.452 1.422	.587	.775	1Rad
THREAD SIZE	THREAD CALL OUT	GRIP RANGE	GRIP CALL OUT	HOLE SIZE	HD	HH	L	D MAX.	IL MAX.	GRIP ID MARK
M6 x 1,0 ISO	610	0,5 - 7,1	7,1	10,15 10,00	16,38 15,49	1,60 1,35	25,78 25,02	9,80	13,21	Blank
M6 x 1,0 ISO	610	7,1 - 12,7	12,7	10,15 10,00	16,38 15,49	1,60 1,35	31,72 30,96	9,80	13,21	1 Rad
M8 x 1,25 ISO	8125	0,5 - 7,1	7,1	12,85 12,70	19,56 18,80	1,70 1,45	29,36 28,60	12,57	19,69	Blank
M8 x 1,25 ISO	8125	7,1 - 12,7	12,7	12,85 12,70	19,56 18,80	1,70 1,45	35,31 34,54	12,57	19,69	1 Rad
M10 x 1,5 ISO	1015	0,5 - 7,1	7,1	15,24 15,09	22,73 21,97	2,36 2,11	31,32 30,61	14,91	19,69	Blank
M10 x 1,5 ISO	1015	7,1 - 12,7	12,7	15,24 15,09	22,73 21,97	2,36 2,11	36,88 36,10	14,91	19,69	1 Rad

NOTE 1: Grip range stated in the dimensional chart above can be achieved using pull type installation tools and may be variable based on hole size and parent material density. AVK recommends trial installations to determine actual grip range in the application.
NOTE 2: Grip ranges will be less than stated above when using torque type installation tools. Grip range will be affected by the tool RPM speed, stall torque, hole size and parent material density. AVK recommends trial installations to determine actual grip. See page 34 for torque tool selection guidelines

PART NUMBERING SYSTEM



SAMPLE NUMBER: ARS3T-420-280

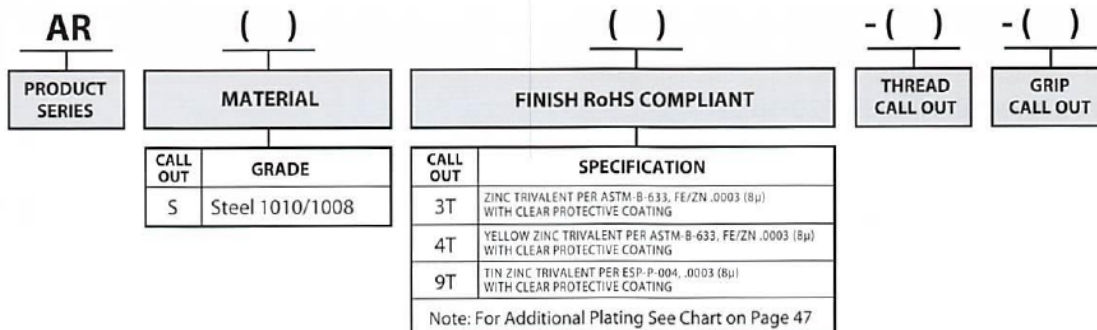

For air tool selection see pages 35 and 37



Get quote >>

Angic Global Solutions 1-888-872-0690
<https://www.AngicGlobal.com> Sales@AngicGlobal.com



A-L SERIES SEALED HEAD INSERT PROFILE

The **A-L Series Sealed Head Insert** provides all the features of the standard A-L Series Insert plus the addition of a PVC foam seal that is bonded to the underside head of the insert. This feature provides a weather resistant seal that will withstand 50 PSI - 3.4 BARS of pressure.

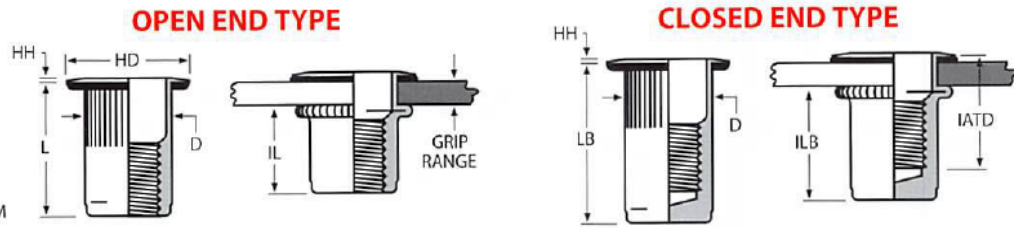

Thread Specifications:
 Unified 2B/21 per ASME B1.1
 Metric 6H/21 per ASME B1.13M

UNIFIED (INCH) AND METRIC THREAD SIZES

THREAD SIZE	THREAD CALL OUT	GRIP RANGE	GRIP CALL OUT	HOLE SIZE +.006 / -.000	HD ±.010 ±.025*	HH ±.003	L ±.015	D MAX.	IL MAX.	LB MAX.	ILB MAX.	IATD** MAX.
6-32 UNC	632	.020 - .060	80	17/64 (.2656)	.390	.030	.420	.265	.305	.755	.640	.610
6-32 UNC	632	.060 - .100	130	17/64 (.2656)	.390	.030	.470	.265	.305	.755	.580	.670
8-32 UNC	832	.020 - .060	80	17/64 (.2656)	.390	.030	.420	.265	.305	.755	.640	.610
8-32 UNC	832	.060 - .100	130	17/64 (.2656)	.390	.030	.470	.265	.305	.755	.580	.670
10-24 UNC	1024	.020 - .100	130	19/64 (.2969)	.415	.030	.475	.296	.315	1.005	.845	.730
10-24 UNC	1024	.100 - .175	225	19/64 (.2969)	.415	.030	.585	.296	.315	1.005	.735	.840
10-32 UNF	1032	.020 - .100	130	19/64 (.2969)	.415	.030	.475	.296	.315	1.005	.845	.730
10-32 UNF	1032	.100 - .175	225	19/64 (.2969)	.415	.030	.585	.296	.315	1.005	.735	.840
1/4-20 UNC	420	.027 - .125	165	25/64 (.3906)	.500	.030	.580	.390	.380	1.205	1.005	.895
1/4-20 UNC	420	.125 - .195	260	25/64 (.3906)	.500	.030	.680	.390	.380	1.205	.905	1.035
5/16-18 UNC	518	.027 - .115	150	17/32 (.5312)	.685*	.035	.690	.530	.470	1.405	1.175	.995
5/16-18 UNC	518	.130 - .250	312	17/32 (.5312)	.685*	.035	.805	.530	.425	1.405	1.025	1.120
3/8-16 UNC	616	.027 - .115	150	17/32 (.5312)	.685*	.035	.690	.530	.470	1.405	1.175	.995
3/8-16 UNC	616	.130 - .250	312	17/32 (.5312)	.685*	.035	.805	.530	.425	1.405	1.025	1.120
1/2-13 UNC	813	.063 - .150	200	11/16 (.6875)	.865*	.047	1.150	.685	.850	2.380	2.070	1.505
1/2-13 UNC	813	.150 - .280	350	11/16 (.6875)	.865*	.047	1.300	.685	.850	2.380	1.920	1.505
1/2-13 UNC	813	.280 - .400	500	11/16 (.6875)	.865*	.047	1.450	.685	.860	2.380	1.770	1.505

THREAD SIZE	THREAD CALL OUT	GRIP RANGE	GRIP CALL OUT	HOLE SIZE +.015 / -.000	HD ±.025 ±.064*	HH ±.008	L ±.038	D MAX.	IL MAX.	LB MAX.	ILB MAX.	IATD** MAX.
M4 x 0,7 ISO	470	0,50 - 1,52	2,0	6,75	9,91	0,76	10,67	6,73	7,75	19,18	16,26	15,49
M4 x 0,7 ISO	470	1,52 - 2,54	3,3	6,75	9,91	0,76	11,94	6,73	7,75	19,18	14,73	17,02
M5 x 0,8 ISO	580	0,50 - 2,54	3,3	7,60	10,54	0,76	12,07	7,52	8,00	25,53	21,46	18,54
M5 x 0,8 ISO	580	2,54 - 4,45	5,7	7,60	10,54	0,76	14,86	7,52	8,00	25,53	18,67	21,34
M6 x 1,0 ISO	610	0,70 - 3,17	4,2	10,00	12,70	0,76	14,73	9,91	9,65	30,61	25,53	22,73
M6 x 1,0 ISO	610	3,17 - 4,95	6,6	10,00	12,70	0,76	17,27	9,91	9,65	30,61	22,99	26,29
M8 x 1,25 ISO	8125	0,70 - 2,92	3,8	13,50	17,40*	0,89	17,53	13,46	11,94	35,69	29,85	25,27
M8 x 1,25 ISO	8125	3,30 - 6,35	7,9	13,50	17,40*	0,89	20,45	13,46	10,80	35,69	26,04	28,45
M10 x 1,5 ISO	1015	0,70 - 2,92	3,8	13,50	17,40*	0,89	17,53	13,46	11,94	35,69	29,85	25,27
M10 x 1,5 ISO	1015	3,30 - 6,35	7,9	13,50	17,40*	0,89	20,45	13,46	10,80	35,69	26,04	28,45
M12 x 1,75 ISO	12175	1,60 - 3,81	5,1	17,45	21,97*	1,19	29,21	17,4	21,59	60,45	52,58	38,23
M12 x 1,75 ISO	12175	3,81 - 7,11	8,9	17,45	21,97*	1,19	33,02	17,4	21,59	60,45	48,77	38,23
M12 x 1,75 ISO	12175	7,11 - 10,16	12,7	17,45	21,97*	1,19	36,83	17,4	21,84	60,45	44,96	38,23

NOTE 1: Grip range can be affected by parent material density and actual hole size. AVK suggests trial installations to determine optimum grip.
 NOTE 2: Additional UNF fine threads are available. Contact an AVK Sales Representative for details.
 NOTE 3: The A-L Series shown on this page incorporates an under head seal which reduces the standard grip range of the part based on the seal thickness. The grip call out remains based on the standard part for part numbering simplicity.
 NOTE 4: The PVC foam seal is not recommended for use with petroleum based liquids. **Dimensions in minimum grip condition.
 ***NOTE 5: Closed End CRES inserts have a reduced "LB" and "ILB" dimension. Contact an AVK sales rep for details.

PART NUMBERING SYSTEM



SAMPLE NUMBER: ALS3T-420-165S

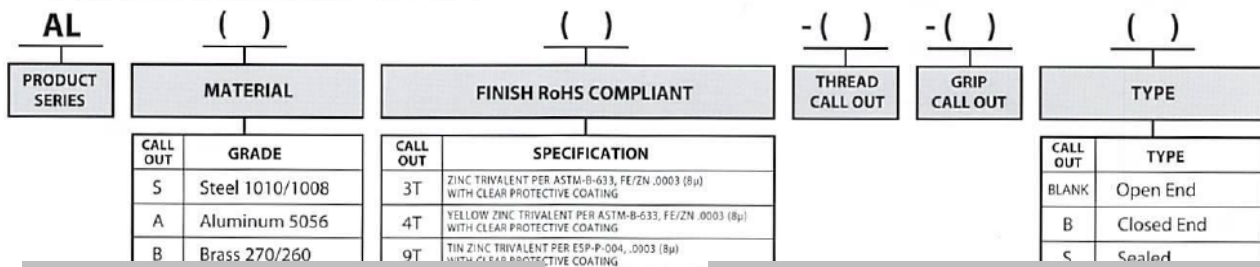

Get quote >>

Plating See Chart on Pa

ool selection on

Angic Global Solutions

1-888-872-0690

<https://www.AngicGlobal.com> Sales@AngicGlobal.com

A-H SERIES SEALED HEAD INSERT PROFILE



SEALED HEAD
THREADED HEX INSERT

The **A-H Series Sealed Head Insert** provides all the features of the standard A-H Series Insert plus the addition of a PVC foam seal that is bonded to the underside head of the insert. This feature provides a weather resistant seal that will withstand 50 PSI–3.4 bars of pressure.

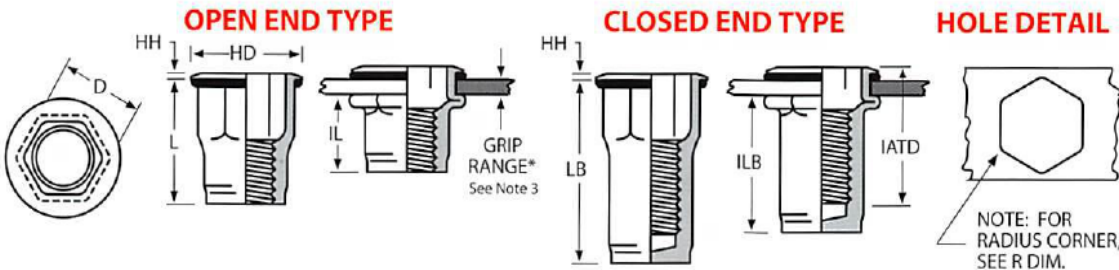

Thread Specifications:
Unified 2B/21 per ASME B1.1
Metric 6H/21 per ASME B1.13M

UNIFIED (INCH) AND METRIC THREAD SIZES

THREAD SIZE	THREAD CALL OUT	GRIP RANGE	GRIP CALL OUT	HOLE SIZE (ACROSS FLATS) +.004 / -.000	HD ±.010 ±.025*	HH ±.003	L ±.015	D MAX.	IL MAX.	LB MAX.	ILB MAX.	IATD** MAX.	R MAX.
6-32 UNC	632	.020 - .060	80	.250	.375	.027	.385	.249	.295	.755	.640	.575	.015
6-32 UNC	632	.060 - .100	130	.250	.375	.027	.435	.249	.295	.755	.580	.640	.015
8-32 UNC	832	.020 - .060	80	.250	.375	.027	.385	.249	.295	.755	.640	.575	.015
8-32 UNC	832	.060 - .100	130	.250	.375	.027	.435	.249	.295	.755	.580	.640	.015
10-24 UNC	1024	.020 - .100	130	.281	.390	.027	.435	.280	.275	1.045	.845	.695	.020
10-24 UNC	1024	.100 - .175	225	.281	.390	.027	.535	.280	.275	1.045	.735	.805	.020
10-32 UNF	1032	.020 - .100	130	.281	.390	.027	.435	.280	.275	1.045	.845	.695	.020
10-32 UNF	1032	.100 - .175	225	.281	.390	.027	.535	.280	.275	1.045	.735	.805	.020
1/4-20 UNC	420	.027 - .125	165	.375	.510	.030	.585	.374	.400	1.205	1.015	.945	.040
1/4-20 UNC	420	.125 - .195	260	.375	.510	.030	.685	.374	.400	1.205	.915	1.085	.040
5/16-18 UNC	518	.027 - .115	150	.500	.655*	.035	.685	.499	.530	1.460	1.235	1.045	.040
5/16-18 UNC	518	.130 - .250	312	.500	.655*	.035	.845	.499	.515	1.460	1.220	1.170	.040
3/8-16 UNC	616	.027 - .115	150	.500	.655*	.035	.685	.499	.530	1.460	1.235	1.045	.040
3/8-16 UNC	616	.130 - .250	312	.500	.655*	.035	.845	.499	.515	1.460	1.220	1.170	.040
1/2-13 UNC	813	.063 - .150	200	.687	.865*	.047	1.150	.686	.850	2.380	2.070	1.505	1.505
1/2-13 UNC	813	.150 - .280	350	.687	.865*	.047	1.300	.686	.850	2.380	1.920	1.505	1.505
1/2-13 UNC	813	.280 - .400	500	.687	.865*	.047	1.450	.686	.860	2.380	1.770	1.505	1.505

THREAD SIZE	THREAD CALL OUT	GRIP RANGE	GRIP CALL OUT	HOLE SIZE (ACROSS FLATS) +.010 / -.000	HD ±.025 ±.064*	HH ±.008	L ±.038	D MAX.	IL MAX.	LB MAX.	ILB MAX.	IATD** MAX.	R MAX.
M4 x 0,7 ISO	470	0,50 - 1,52	2.0	6,35	9,53	0,68	9,78	6,35	7,49	19,18	16,26	14,61	0,38
M4 x 0,7 ISO	470	1,52 - 2,54	3.3	6,35	9,53	0,68	11,05	6,35	7,49	19,18	14,73	16,26	0,38
M5 x 0,8 ISO	580	0,50 - 2,54	3.3	7,14	9,91	0,68	11,05	7,10	6,99	26,54	21,46	17,65	0,50
M5 x 0,8 ISO	580	2,54 - 4,45	5.7	7,14	9,91	0,68	13,59	7,10	6,99	26,54	18,67	20,45	0,50
M6 x 1,0 ISO	610	0,70 - 3,17	4.2	9,53	12,96	0,76	14,86	9,50	10,16	30,61	25,78	24,00	1,00
M6 x 1,0 ISO	610	3,17 - 4,95	6.6	9,53	12,96	0,76	17,40	9,50	10,16	30,61	23,24	27,56	1,00
M8 x 1,25 ISO	8125	0,70 - 2,92	3.8	12,70	16,64*	0,89	17,40	12,70	13,46	37,08	31,37	26,54	1,00
M8 x 1,25 ISO	8125	3,30 - 6,35	7.9	12,70	16,64*	0,89	21,46	12,70	13,08	37,08	30,99	29,72	1,00
M10 x 1,5 ISO	1015	0,70 - 2,92	3.8	12,70	16,64*	0,89	17,40	12,70	13,46	37,08	31,37	26,54	1,00
M10 x 1,5 ISO	1015	3,30 - 6,35	7.9	12,70	16,64*	0,89	21,46	12,70	13,08	37,08	30,99	29,72	1,00
M12 x 1,75 ISO	12175	1,60 - 3,81	5.1	17,45	21,97*	1,19	29,21	17,42	21,59	60,45	52,58	38,23	38,23
M12 x 1,75 ISO	12175	3,81 - 7,11	8.9	17,45	21,97*	1,19	33,02	17,42	21,59	60,45	48,77	38,23	38,23
M12 x 1,75 ISO	12175	7,11 - 10,16	12.7	17,45	21,97*	1,19	36,83	17,42	21,84	60,45	44,96	38,23	38,23

NOTE 1: Grip range can be affected by parent material density and actual hole size. AVK suggests trial installations to determine optimum grip.
 NOTE 2: Additional UNF fine threads are available. Contact an AVK Sales Representative for details.
 NOTE 3: The A-H Series shown on this page incorporates an under head seal which reduces the standard grip range of the part based on the seal thickness. The grip call out remains based on the standard part for part numbering simplicity.
 NOTE 4: The PVC foam seal is not recommended for use with petroleum based liquids. **Dimensions in minimum grip condition.
 ***NOTE 5: Closed End CRES inserts have a reduced "LB" and "ILB" dimension. Contact an AVK sales rep for details.

PART NUMBERING SYSTEM



SAMPLE NUMBER: AHS3T-420-1655

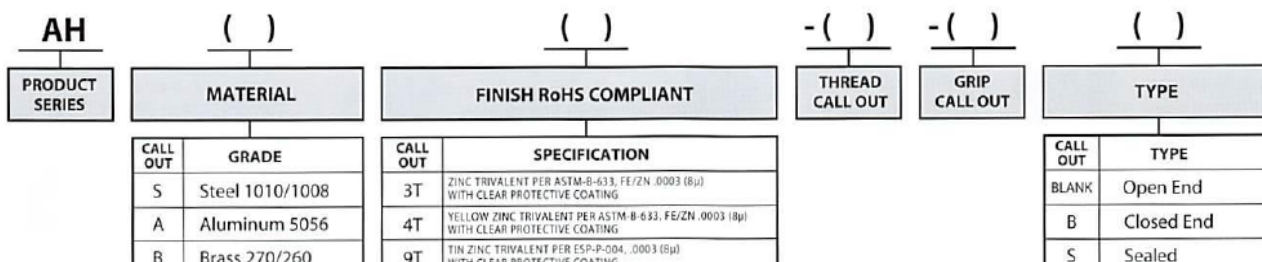

Get quote >>

See Chart on Page 47

Selection on page

Angic Global Solutions

<https://www.AngicGlobal.com>

1-888-872-0690

Sales@AngicGlobal.com

19



A-S SERIES STUD PROFILE

The **A-S Series Stud** offers a unique design advantage in that once installed, a threaded stud is left protruding from the workpiece. Component parts can be located on the stud until final assembly is accomplished with a mating nut. The A-S series is an ideal alternative to clinch or weld studs. The A-S Series is designed to be used with Grade 5 or Metric Class 8.8/9.8 non thread locking type nuts.

The A-S Series Stud is installed using AVK's ARO brand pneumatic tools or AVK's SPP™ pneumatic/hydraulic tool systems. These tools can be located at any position on your assembly line. The A-S Series Stud can be installed either before or after finish.



SPINWALL TECHNOLOGY™

HOW HOLE FILL WORKS FOR YOU

As the A-S Series is installed, the knurled body expands 360° **FILLING THE HOLE.** This feature provides exceptional torque strength and vibration resistance.

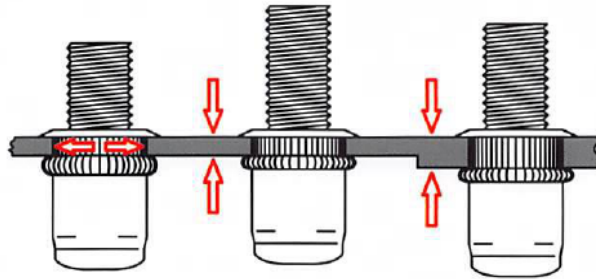

The installation tool then continues to install the stud forming a backside flange even in variable thickness material **WITHOUT ADJUSTMENT.**

DESIGN BENEFITS

- **PROTRUDING STUD** allows component parts to be located on the stud until final assembly is accomplished with a mating nut.
- **EXCEPTIONAL TORQUE STRENGTH** is achieved as the stud's knurled body expands **FILLING THE HOLE.**
- **QUALITY INSTALLATIONS** even in variable thickness materials are assured by AVK's spin/spin ARO pneumatic or AVK's pneumatic/hydraulic SPP Tool™ systems.
- **ELIMINATE PAINT MASKING** procedures as required with weld or clinch studs. The A-S Series Stud can be installed after painting.
- **SUPERIOR CORROSION RESISTANCE** is provided by our standard zinc/yellow trivalent finish (120 hours. Salt spray to white corrosion). Alternative finishes are available.
- **AVAILABLE** in Steel 1010/1008 shell - Steel 1038 threaded stud.

ADDITIONAL DESIGN TYPES

SEALED HEAD

A PVC foam seal is bonded to the underside of the head and when installed provides a weather tight seal. Note that the addition of a seal reduces the parts grip range. Contact an AVK Sales Representative for more information.



WEDGE HEAD

The addition of wedges under the head provides even greater torque capability, especially in soft or thin materials, and is excellent for electrical grounding applications. Contact an AVK Sales Representative for more information.



HEX BODY

The hex shell offers exceptional resistance to spinning once installed. Also available in full body hex version. Contact an AVK Sales Representative for more information.



DOG POINT

An optional Dog-Point provides ease in installing mating hardware and reduces the possibility of cross-threading. AVK offers Dog-Points in a variety of configurations. Contact an AVK Sales Representative for more information.



UNIFIED (INCH) AND METRIC THREAD SIZES



STUD
CAPTIVE THREADED STUD

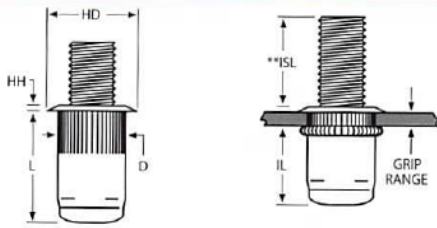

**NOTE: The ISL Dimension shown below is the height of the installed stud at max grip. The height of the stud will increase if it is installed into thinner material. To calculate actual ISL use this formula: Max grip - actual grip + ISL = Actual ISL

Thread Specifications: Unified 2A/21 per ASME B1.1
Metric 6G/21 per ASME B1.13M

THREAD SIZE	THREAD CALL OUT	GRIP RANGE	GRIP CALL OUT	STUD LENGTHS**			HOLE SIZE +.006 / -.000	HD ±.010 ±.025*	HH ±.003	L ±.020	D MAX.	IL MAX.
				ISL CALL OUT	ISL CALL OUT	ISL CALL OUT						
6-32 UNC	632	.020-.080	80	.500 500	.625 625	.750 750	17/64 (.2656)	.390	.030	.485	.265	.360
6-32 UNC	632	.080-.130	130	.450 400	.575 575	.700 700	17/64 (.2656)	.390	.030	.535	.265	.360
8-32 UNC	832	.020-.080	80	.500 500	.625 625	.750 750	17/64 (.2656)	.390	.030	.485	.265	.360
8-32 UNC	832	.080-.130	130	.450 400	.575 575	.700 700	17/64 (.2656)	.390	.030	.535	.265	.360
10-24 UNC	1024	.020-.130	130	.500 500	.625 625	.750 750	19/64 (.2969)	.415	.030	.545	.296	.380
10-24 UNC	1024	.130-.225	225	.405 405	.530 530	.655 655	19/64 (.2969)	.415	.030	.655	.296	.380
10-32 UNF	1032	.020-.130	130	.500 500	.625 625	.750 750	19/64 (.2969)	.415	.030	.545	.296	.380
10-32 UNF	1032	.130-.225	225	.405 405	.530 530	.655 655	19/64 (.2969)	.415	.030	.655	.296	.380
1/4-20 UNC	420	.027-.165	165	.625 625	.8125 8125	1.000 1000	25/64 (.3906)	.500	.030	.670	.390	.465
1/4-20 UNC	420	.165-.260	260	.530 530	.7175 7175	.905 905	25/64 (.3906)	.500	.030	.770	.390	.465
5/16-18 UNC	518	.027-.150	150	.625 625	.875 875	1.125 1125	17/32 (.5312)	.685*	.035	.810	.530	.600
5/16-18 UNC	518	.150-.312	312	.463 463	.713 713	.963 963	17/32 (.5312)	.685*	.035	.925	.530	.555
3/8-16 UNC	616	.027-.150	150	.750 750	1.000 1000	1.250 1250	17/32 (.5312)	.685*	.035	.810	.530	.600
3/8-16 UNC	616	.150-.312	312	.588 588	.838 838	1.088 1088	17/32 (.5312)	.685*	.035	.925	.530	.535

THREAD SIZE	THREAD CALL OUT	GRIP RANGE	GRIP CALL OUT	STUD LENGTHS**			HOLE SIZE +.015 / -.000	HD ±0,25 ±0,64*	HH ±0,08	L ±0,50	D MAX.	IL MAX.
				ISL CALL OUT	ISL CALL OUT	ISL CALL OUT						
M4 x 0,7 ISO	470	0,50 - 2,00	2,0	12,0 12	15,0 15	20,0 20	6,75	9,91	0,76	12,32	6,73	9,15
M4 x 0,7 ISO	470	2,00 - 3,30	3,3	10,7 10,7	13,7 13,7	18,7 18,7	6,75	9,91	0,76	13,59	6,73	9,15
M5 x 0,8 ISO	580	0,50 - 3,30	3,3	12,0 12	15,0 15	20,0 20	7,60	10,54	0,76	13,84	7,52	9,65
M5 x 0,8 ISO	580	3,30 - 5,70	5,7	9,6 9,6	12,6 12,6	17,6 17,6	7,60	10,54	0,76	16,64	7,52	9,65
M6 x 1,0 ISO	610	0,70 - 4,20	4,2	15,0 15	20,0 20	25,0 25	10,00	12,70	0,76	17,02	9,91	11,81
M6 x 1,0 ISO	610	4,20 - 6,60	6,6	12,6 12,6	17,6 17,6	22,6 22,6	10,00	12,70	0,76	19,56	9,91	11,81
M8 x 1,25 ISO	8125	0,70 - 3,80	3,8	16,0 16	22,0 22	28,0 28	13,50	17,40*	0,89	20,57	13,46	15,24
M8 x 1,25 ISO	8125	3,80 - 7,90	7,9	11,9 11,9	17,9 17,9	23,9 23,9	13,50	17,40*	0,89	23,50	13,46	14,10
M10 x 1,5 ISO	1015	0,70 - 3,80	3,8	20,0 20	25,0 25	30,0 30	13,50	17,40*	0,89	20,57	13,46	15,24
M10 x 1,5 ISO	1015	3,80 - 7,90	7,9	15,9 15,9	20,9 20,9	25,9 25,9	13,50	17,40*	0,89	23,50	13,46	13,60

NOTE 1: Grip range can be affected by parent material density and actual hole size. AVK suggests trial installations to determine optimum grip.

NOTE 2: Additional UNF fine threads are available. Contact an AVK Sales Representative for details.

**Dimensions in maximum grip condition.

PART NUMBERING SYSTEM



SAMPLE NUMBER: ASS3T-420-165-625

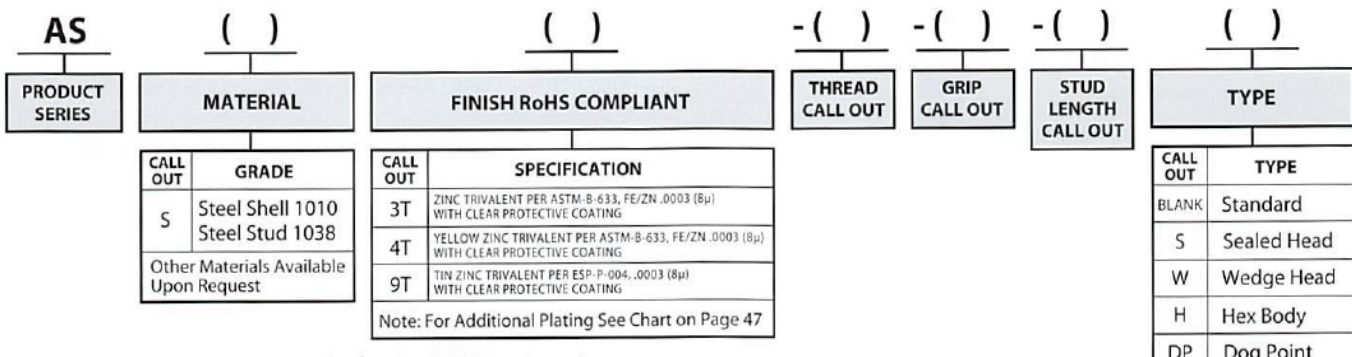

Get quote >>

Angic Global Solutions

1-888-872-0690

<https://www.AngicGlobal.com> Sales@AngicGlobal.com



A-T SERIES INSERT PROFILE

The **A-T Series Insert** is unique in that it can be installed into most any material above .030/.76 mm in thickness. As the A-T Series is installed, the threaded portion is completely swaged 360° into the sleeve portion and the hole. This permits the A-T Series to be used with Grade 8/Metric 12.9 mating screws.

The A-T Series Insert is installed using lightweight, handheld pneumatic ARO tools that can be located at any position in your product's assembly sequence. The A-T Series Insert can be installed either prior to or after finish.



360° SWAGING HOW IT WORKS FOR YOU

As the A-T Series Insert is installed, the threaded nut portion is drawn into the upper sleeve portion.

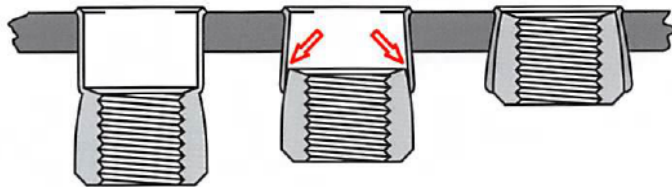

As this occurs a 360° swaging action takes place anchoring A-T Series Insert in the parent material.

DESIGN BENEFITS

- **REDUCED OVERALL LENGTH** of the installed A-T Series Insert allows it to be used in limited clearance applications.
- **QUALITY INSTALLATIONS** even in variable thickness materials are assured by our spin/spin torque stall tools (featured on page 30).
- **INVENTORY REDUCTION** is possible because one A-T Series Insert will work in any thickness.
- **INSTALLS INTO MOST ANY MATERIAL** with a thickness over .030/.76 mm.
- **CAN BE USED WITH GRADE 8/METRIC CLASS 12.9 SCREWS** due to the A-T Series high shear load capability.
- **AVAILABLE** in Steel, Aluminum, Brass and Series 304 Stainless Steel are available by special order. Contact an AVK Sales Representative for details.

ADDITIONAL DESIGN TYPES

CLOSED END

Thread area is enclosed eliminating leakage past the threads from either side of the application. See page 23.



JOINT DESIGN PRACTICES

AVK recommends that the mating part comes in contact with the head of the A-T Series Insert. If a gap or clearance hole exists between the mating part and the A-T Series Insert, the threaded nut portion may rotate or pull through the parent material.

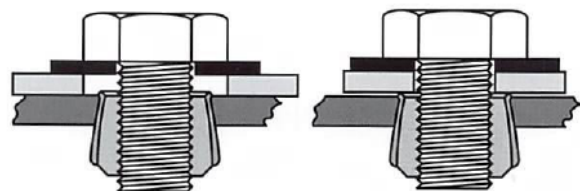

NOT RECOMMENDED

RECOMMENDED

UNIFIED (INCH) AND METRIC THREAD SIZES



INSERT
KNURLED THREADED INSERTS

OPEN END TYPE

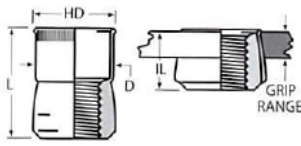

CLOSED END TYPE

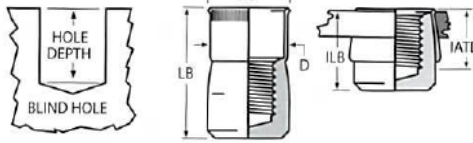

THREAD SIZE	THREAD CALL OUT	HD ±.005	L ±.015	D MAX.	IL REF.	LB ±.015	ILB REF.	IATD MAX.	HOLE DEPTH MIN.
4-40 UNC	440	.211	.370	.1875	.205	.660	.495	.395	.400
6-32 UNC	632	.240	.370	.2185	.205	.675	.505	.410	.400
8-32 UNC	832	.269	.370	.2495	.205	.675	.505	.410	.400
10-24 UNC	1024	.306	.370	.2805	.205	.685	.520	.385	.400
10-32 UNF	1032	.306	.370	.2805	.205	.685	.520	.385	.400
1/4-20 UNC	420	.400	.515	.3745	.275	1.005	.760	.615	.540
5/16-18 UNC	518	.528	.615	.4995	.325	1.065	.770	.630	.640
3/8-16 UNC	616	.588	.745	.5615	.390	1.450	1.095	.890	.770
1/2-13 UNC	813	.800	.935	.7485	.485	NA	NA	NA	.960

THREAD SIZE	THREAD CALL OUT	HD ±0,13	L ±0,38	D MAX.	IL REF.	LB ±0,38	ILB REF.	IATD MAX.	HOLE DEPTH MIN.
M3 x 0,5 ISO	350	5,36	9,40	4,76	5,21	16,77	12,57	10,03	10,16
M4 x 0,7 ISO	470	6,83	9,40	6,34	5,21	17,15	12,83	10,41	10,16
M5 x 0,8 ISO	580	7,77	9,40	7,12	5,21	17,40	13,21	9,78	10,16
M6 x 1,0 ISO	610	10,16	13,08	9,51	6,99	25,53	19,30	15,62	13,72
M8 x 1,25 ISO	8125	13,41	15,62	12,69	8,26	27,05	19,56	16,00	16,26
M10 x 1,5 ISO	1015	14,94	18,92	14,26	9,91	36,83	27,81	22,61	19,56
M12 x 1,75 ISO	12175	20,32	23,75	19,01	12,32	NA	NA	NA	24,38

HOLE SIZE / MATERIAL THICKNESS CHART

THREAD SIZE	.030 - .090 MAT. THICKNESS		.091 - .124 MAT. THICKNESS		.125 - .186 MAT. THICKNESS		.187 - OVER MAT. THICKNESS	
	DRILL SIZE	DECIMAL	DRILL SIZE	DECIMAL	DRILL SIZE	DECIMAL	DRILL SIZE	DECIMAL
4-40 UNC	3/16	.1875	#10	.1935	#10	.1935	#9	.1960
6-32 UNC	7/32	.2188	#2	.2210	#1	.2280	#1	.2280
8-32 UNC	1/4	.2500	"F"	.2570	17/64	.2656	17/64	.2656
10-24 UNC	9/32	.2812	"L"	.2900	"L"	.2900	19/64	.2969
10-32 UNF	9/32	.2812	"L"	.2900	"L"	.2900	19/64	.2969
1/4-20 UNC	3/8	.3750	3/8	.3750	"W"	.3860	25/64	.3906
5/16-18 UNC	1/2	.5000	1/2	.5000	33/64	.5156	33/64	.5156
3/8-16 UNC	9/16	.5625	9/16	.5625	37/64	.5781	37/64	.5781
1/2-13 UNC	3/4	.7500	49/64	.7656	25/32	.7810	51/64	.7970

THREAD SIZE	0,76 - 2,29 MAT. THICKNESS		2,31 - 3,15 MAT. THICKNESS		3,17 - 4,72 MAT. THICKNESS		4,72 - OVER MAT. THICKNESS	
	DRILL SIZE	DECIMAL	DRILL SIZE	DECIMAL	DRILL SIZE	DECIMAL	DRILL SIZE	DECIMAL
M3 x 0,5 ISO	4,75	.1875	4,90	.1935	4,90	.1935	4,97	.1960
M4 x 0,7 ISO	6,35	.2500	6,52	.2570	6,74	.2656	6,74	.2656
M5 x 0,8 ISO	7,14	.2812	7,36	.2900	7,36	.2900	7,54	.2969
M6 x 1,0 ISO	9,52	.3750	9,52	.3750	9,80	.3860	9,92	.3906
M8 x 1,25 ISO	12,70	.5000	12,70	.5000	13,09	.5156	13,09	.5156
M10 x 1,5 ISO	14,28	.5625	14,28	.5625	14,68	.5781	14,68	.5781
M12 x 1,75 ISO	19,05	.7500	19,44	.7656	19,83	.7810	20,24	.7970

FINISH: The standard specified finish for the A-T Series Insert is tin. Alteration to this finish will reduce performance.*THREAD CLASS: The A-T Series Insert's internal threads are manufactured oversized to compensate for resulting thread portion shrinkage during the installation swaging process. They are not gaugeable prior to or after installation but will be compatible with Class 2A/3A or 6g screws after installation.

NOTE: Hole sizes: The application should be tested before hole size is specified.

PART NUMBERING SYSTEM

SAMPLE NUMBER: AT55-610

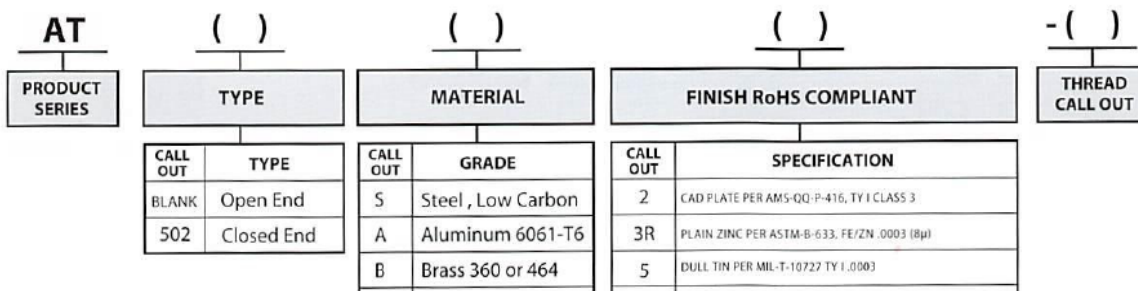

MATERIAL TYPE IDENTIFICATION GROOVES

All materials for the A-T Series when plated look similar. Radial grooves are machined into the part for material identification.

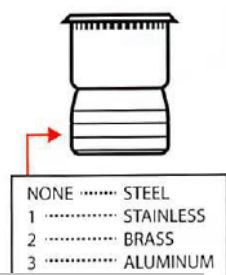

Get quote >>

For Additional Plating: **Angic Global Solutions**
<https://www.AngicGlobal.com>

1-888-872-0690

Sales@AngicGlobal.com

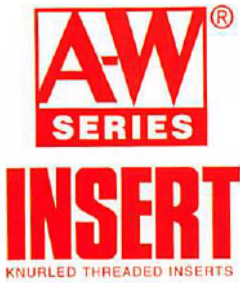

A-W SERIES INSERT PROFILE

The **A-W Series Insert** can be installed into most any material softer than itself that is thicker than .062/1,57. The A-W Series provides exceptional shear strength and pull out in fiberglass and plywoods. The brass A-W Series Insert is particularly useful for the fiberglass boat industry.

The A-W Series Insert is installed using lightweight, handheld pneumatic tools that can be located at any position in your product's assembly sequence. The A-W Series Insert can be installed either prior to or after finish.

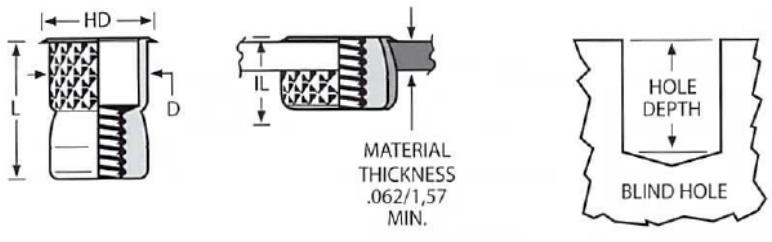

UNIFIED (INCH) AND METRIC THREAD

THREAD SIZE	THREAD CALL OUT	HOLE SIZE +.005 / -.000	HD ±.005	L ±.015	D MAX.	IL REF.	HOLE DEPTH MIN.
6-32 UNC	632	15/64 (.234)	.255	.370	.233	.205	.400
8-32 UNC	832	17/64 (.266)	.285	.370	.264	.205	.400
10-24 UNC	1024	19/64 (.297)	.320	.370	.295	.205	.400
10-32 UNF	1032	19/64 (.297)	.320	.370	.295	.205	.400
1/4-20 UNC	420	25/64 (.391)	.415	.515	.389	.275	.540
5/16-18 UNC	518	17/32 (.531)	.550	.615	.528	.325	.640
3/8-16 UNC	616	19/32 (.594)	.615	.740	.590	.390	.770

THREAD SIZE	THREAD CALL OUT	HOLE SIZE +0,13 / -0,00	HD ±0,13	L ±0,38	D MAX.	IL REF.	HOLE DEPTH MIN.
M4 x 0,7 ISO	470	6,75	7,24	9,40	6,71	5,21	10,16
M5 x 0,8 ISO	580	7,54	8,13	9,40	7,50	5,21	10,16
M6 x 1,0 ISO	610	9,92	10,54	13,08	9,88	6,99	13,72
M8 x 1,25 ISO	8125	13,49	13,97	15,62	13,41	8,26	16,26
M10 x 1,5 ISO	1015	15,00	15,62	18,80	14,99	9,91	19,56

NOTE 1: Additional UNF thread sizes available. Contact an AVK Sales Representative for details.
 NOTE 2: HOLE SIZE: The A-W Series Insert hole size will be dependent on parent material density. Experimentation is required for optimum performance.
 NOTE 3: FINISH: The standard specified finish for the A-W Series Insert is tin. Alteration to this finish will reduce performance.
 *THREAD CLASS: The A-W Series Insert's internal threads are manufactured oversized to compensate for resulting thread portion shrinkage during the installation swaging process. They are not gaugeable prior to or after installation but will be compatible with Class 2A/3A or 6g screws after installation.

PART NUMBERING SYSTEM

SAMPLE NUMBER: AWS5-420

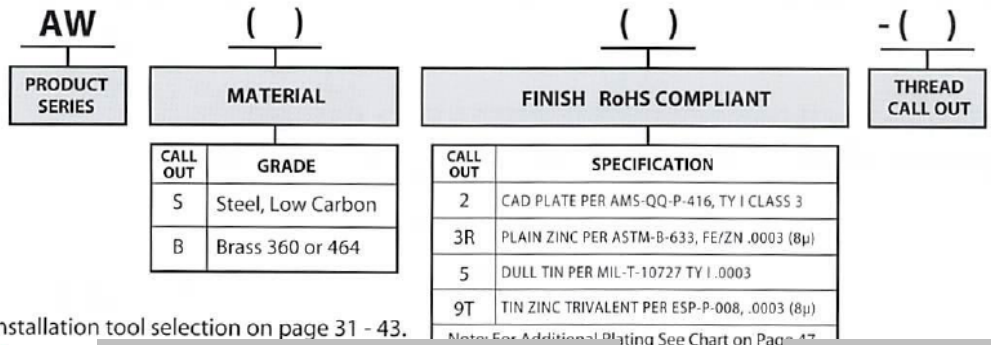

MATERIAL TYPE IDENTIFICATION GROOVES
 All materials for the A-W Series when plated look similar. Radial grooves are machined into the part for material identification.

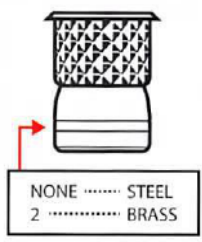

See installation tool selection on page 31 - 43.

A-O SERIES PROFILE



The A-O Series Insert features a reduced profile head design which is similar to the superior A-K Series Insert. It also has a smaller body diameter than the A-K Series Insert. The A-O Series Insert can be specified when the application design parameters require a smaller hole or closer hole to edge tolerances.

The A-O Series can be installed with AVK's ARO brand pneumatic tools or AVK's pneumatic/hydraulic SPP Tool™ system. These tools can be located at any position on your assembly line. The A-O Series can be installed either prior to or after finish further enhancing its flexibility in your manufacturing environment.

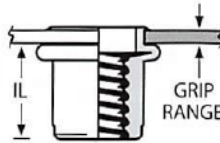
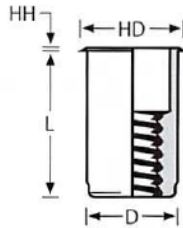

Thread Specifications: Unified 2B/21 per ASME B1.1
Metric 6H/21 per ASME B1.13M



UNIFIED (INCH) AND METRIC THREAD

THREAD SIZE	THREAD CALL OUT	GRIP RANGE	GRIP CALL OUT	HOLE SIZE +.006 / -.000	HD ±.010	HH ±.003	L ±.015	D MAX.	IL MAX.
6-32 UNC	632	.020 - .080	80	1/4 (.250)	.300	.018	.385	.249	.315
8-32 UNC	832	.020 - .080	80	1/4 (.250)	.300	.018	.385	.249	.315
10-24 UNC	1024	.020 - .130	130	9/32 (.2812)	.320	.020	.440	.280	.330
10-32 UNF	1032	.020 - .130	130	9/32 (.2812)	.320	.020	.440	.280	.330
1/4-20 UNC	420	.030 - .165	165	3/8 (.375)	.425	.022	.580	.374	.440
5/16-18 UNC	518	.040 - .200	200	1/2 (.500)	.560	.022	.690	.499	.540
3/8-16 UNC	616	.040 - .200	200	1/2 (.500)	.560	.022	.690	.499	.540

THREAD SIZE	THREAD CALL OUT	GRIP RANGE	GRIP CALL OUT	HOLE SIZE +0,15 / -0,00	HD ±0,25	HH ±0,08	L ±0,38	D MAX.	IL MAX.
M4 x 0,7 ISO	470	0,50 - 2,00	2,0	6,4	7,49	0,46	9,78	6,32	8,00
M5 x 0,8 ISO	580	0,50 - 3,30	3,3	7,2	8,13	0,51	11,18	7,11	8,38
M6 x 1,0 ISO	610	0,76 - 4,20	4,2	9,6	10,80	0,56	14,73	9,50	11,18
M8 x 1,25 ISO	8125	1,02 - 5,10	5,1	12,7	14,22	0,56	17,53	12,67	13,72
M10 x 1,5 ISO	1015	1,02 - 5,10	5,1	12,7	14,22	0,56	17,53	12,67	13,72

NOTE 1: Grip range can be affected by parent material density and actual hole size. AVK suggests trial installations to determine optimum grip.

NOTE 2: UNF fine threads are available. Contact an AVK Sales Representative for details.

PART NUMBERING SYSTEM



SAMPLE NUMBER: AOS4T-420-165

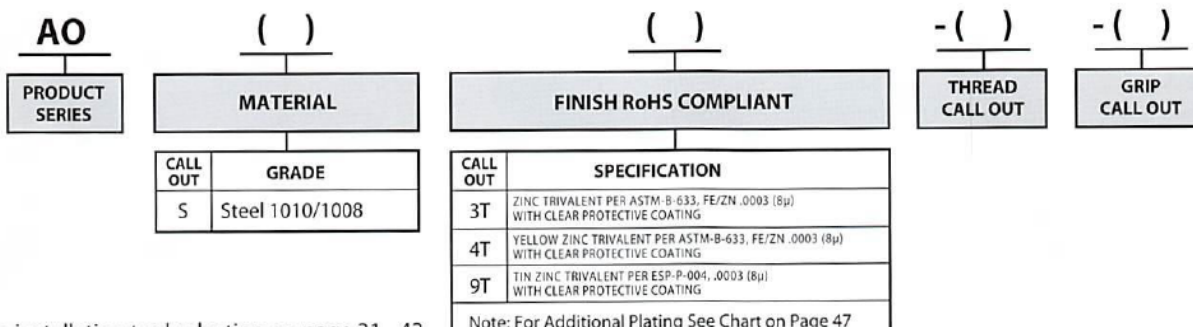

Note: For Additional Plating See Chart on Page 47

See installation tool selection on page 31 - 43



Get quote >>

Angic Global Solutions

1-888-872-0690

<https://www.AngicGlobal.com> Sales@AngicGlobal.com



R-N SERIES RIVET NUT PROFILE

The Steel **R-N Series Rivet Nut** features a heavy duty head profile and increased wall thickness in the collapse area. This makes the R-N Series ideal for leg leveling applications as shown on page 8. The Steel R-N Series is designed to be used with Grade 5 or Metric Class 8.8/9.8 mating screws.

The R-N Series Rivet Nut can be installed using AVK's pneumatic/ hydraulic SPP ToolTM systems or the specific rivet nut tools shown on page 36. The R-N Series Rivet Nut's heavier wall thickness and resulting upset load requires this type of tool be used for installation. The R-N Series can be installed either prior to or after finish.



COLD FORMING TECHNOLOGYTM

HOW IT WORKS FOR YOU

The R-N Series Rivet Nuts are manufactured using state-of-the-art cold forming technology. This provides very precise tolerances. All surfaces of the R-N Series are **FORMED**, not machined. This provides excellent quality.

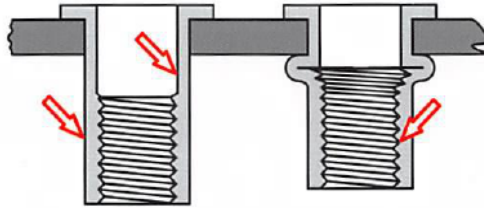

The internal thread of the R-N Series Rivet Nut is roll **FORMED** not machined. This provides excellent thread strength.

DESIGN BENEFITS

- **INCREASED PUSH-OUT LOADS** are achievable in leg leveling applications when using the R-N Series due to its heavy duty head profile and thick wall construction.
- **SUPERIOR THREAD STRENGTH** is provided due to our internal rolled thread manufacturing process.
- **SUPERIOR CORROSION RESISTANCE** is provided by our "9T" finish (500 hours plus) see page 47.
- **UNIFORM INSTALLATION** is guaranteed because of the dimensional tolerances and concentricity tolerances built into our product made possible by our cold forming technology.
- **AVAILABLE** in steel and aluminum. For additional materials, contact AVK for availability.
- **NAS1329 and NAS1330** with "DFAR" material is available upon request.

ADDITIONAL DESIGN TYPES

CLOSED END

Thread area is enclosed eliminating leakage past the threads from either side of the application. Contact an AVK Sales Representative for availability.



KEYED HEAD

An underside of the head "key" projection when placed into a matching "keyed" hole design provides additional torque resistance. Contact an AVK Sales Representative for availability.



100° COUNTERSUNK HEAD

A 100° countersunk head profile when installed into a matching countersunk hole provides a flush installation. Contact an AVK Sales Representative for availability.



FLATHEAD UNIFIED (INCH) AND METRIC THREAD SIZES



RIVET NUT
THREADED INSERT

"M" INDICATES
METRIC THREAD

OPEN END TYPE

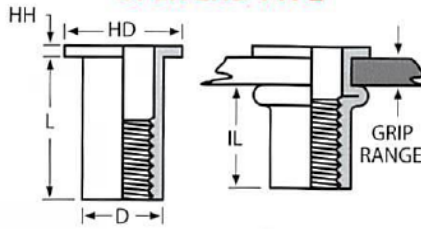
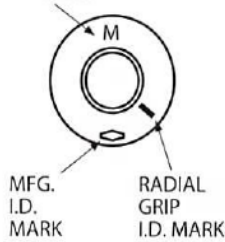

Thread Specifications: Unified MIL-S-7742/ASME-B1.1
Metric 6H/21 per ASME B1.13M

THREAD SIZE	THREAD CALL OUT	GRIP RANGE	GRIP CALL OUT	I.D. MARK	HOLE SIZE +.003 / -.000	HD ±.015	HH NOM.	L ±.015	D +.000 -.004	IL REF.
4-40 UNC	440	.010 - .060	60	BLANK	5/32 (.155)	.270	.025	.345	.155	.230
4-40 UNC	440	.060 - .085	85	1-RAD	5/32 (.155)	.270	.025	.370	.155	.230
4-40 UNC	440	.085 - .110	110	2-RAD	5/32 (.155)	.270	.025	.400	.155	.230
6-32 UNC	632	.010 - .075	75	1-RAD	#12 (.189)	.325	.032	.438	.189	.300
6-32 UNC	632	.075 - .120	120	3-RAD	#12 (.189)	.325	.032	.500	.189	.315
6-32 UNC	632	.120 - .160	160	5-RAD	#12 (.189)	.325	.032	.500	.189	.270
8-32 UNC	832	.010 - .075	75	1-RAD	#2 (.221)	.357	.032	.438	.221	.300
8-32 UNC	832	.075 - .120	120	3-RAD	#2 (.221)	.357	.032	.500	.221	.315
8-32 UNC	832	.120 - .160	160	5-RAD	#2 (.221)	.357	.032	.500	.221	.270
10-32 UNF	1032	.010 - .080	80	BLANK	1/4 (.250)	.406	.038	.531	.250	.380
10-32 UNF	1032	.080 - .130	130	1-RAD	1/4 (.250)	.406	.038	.594	.250	.390
10-32 UNF	1032	.130 - .180	180	2-RAD	1/4 (.250)	.406	.038	.641	.250	.390
1/4-20 UNC	420	.020 - .080	80	BLANK	Q (.332)	.475	.058	.625	.332	.450
1/4-20 UNC	420	.080 - .140	140	1-RAD	Q (.332)	.475	.058	.687	.332	.450
1/4-20 UNC	420	.140 - .200	200	2-RAD	Q (.332)	.475	.058	.750	.332	.450
5/16-18 UNC	518	.030 - .125	125	BLANK	Z (.413)	.665	.062	.750	.413	.505
5/16-18 UNC	518	.125 - .200	200	1-RAD	Z (.413)	.665	.062	.875	.413	.555
5/16-18 UNC	518	.200 - .275	275	2-RAD	Z (.413)	.665	.062	.937	.413	.540
3/8-16 UNC	616	.030 - .115	115	BLANK	12.5mm (.490)	.781	.088	.844	.490	.585
3/8-16 UNC	616	.115 - .200	200	1-RAD	12.5mm (.490)	.781	.088	.938	.490	.595
3/8-16 UNC	616	.200 - .285	285	2-RAD	12.5mm (.490)	.781	.088	1.031	.490	.605
1/2-13 UNC	813	.050 - .150	150	BLANK	5/8 (.625)	.906	.085	.906	.625	.605
1/2-13 UNC	813	.150 - .250	250	1-RAD	5/8 (.625)	.906	.085	1.031	.625	.630
1/2-13 UNC	813	.250 - .350	350	2-RAD	5/8 (.625)	.906	.085	1.141	.625	.640

THREAD SIZE	THREAD CALL OUT	GRIP RANGE	GRIP CALL OUT	I.D. MARK	HOLE SIZE +0,08 / -0,00	HD ±0,38	HH NOM.	L ±0,38	D +0,00 -0,10	IL REF.
M3 x 0,5 ISO	350	0,25 - 1,00	1,0	BLANK	3,94	6,68	0,63	8,00	3,93	5,61
M3 x 0,5 ISO	350	1,00 - 1,75	1,75	1-RAD	3,94	6,68	0,63	8,75	3,93	5,61
M3 x 0,5 ISO	350	1,75 - 2,50	2,5	2-RAD	3,94	6,68	0,63	9,50	3,93	5,61
M4 x 0,7 ISO	470	0,25 - 2,00	2,0	BLANK	5,60	9,01	0,81	11,00	5,61	7,08
M4 x 0,7 ISO	470	2,00 - 3,00	3,0	1-RAD	5,60	9,01	0,81	12,00	5,61	7,08
M4 x 0,7 ISO	470	3,00 - 4,00	4,0	2-RAD	5,60	9,01	0,81	13,00	5,61	7,08
M5 x 0,8 ISO	580	0,25 - 2,00	2,0	BLANK	7,20	11,17	1,22	14,50	7,13	10,09
M5 x 0,8 ISO	580	2,00 - 3,50	3,5	1-RAD	7,20	11,17	1,22	16,00	7,13	10,09
M5 x 0,8 ISO	580	3,50 - 5,00	5,0	2-RAD	7,20	11,17	1,22	17,50	7,13	10,09
M6 x 1,0 ISO	610	0,75 - 2,00	2,0	BLANK	8,50	13,43	1,47	15,50	8,43	10,58
M6 x 1,0 ISO	610	2,00 - 3,50	3,5	1-RAD	8,50	13,43	1,47	17,00	8,43	10,58
M6 x 1,0 ISO	610	3,50 - 5,00	5,0	2-RAD	8,50	13,43	1,47	18,50	8,43	10,58
M8 x 1,25 ISO	8125	1,00 - 3,00	3,0	BLANK	10,50	16,65	1,57	18,00	10,48	11,83
M8 x 1,25 ISO	8125	3,00 - 5,00	5,0	1-RAD	10,50	16,65	1,57	20,00	10,48	11,83
M8 x 1,25 ISO	8125	5,00 - 7,00	7,0	2-RAD	10,50	16,65	1,57	22,00	10,48	11,83
M10 x 1,5 ISO	1015	1,00 - 3,00	3,0	BLANK	12,50	19,50	2,23	20,00	12,44	13,20
M10 x 1,5 ISO	1015	3,00 - 5,50	5,5	1-RAD	12,50	19,50	2,23	22,50	12,44	13,20
M10 x 1,5 ISO	1015	5,50 - 8,00	8,0	2-RAD	12,50	19,50	2,23	25,00	12,44	13,20
M12 x 1,75 ISO	12175	1,00 - 3,00	3,0	BLANK	15,50	22,79	2,23	24,00	15,46	16,45
M12 x 1,75 ISO	12175	3,00 - 5,50	5,5	1-RAD	15,50	22,79	2,23	26,50	15,46	16,45
M12 x 1,75 ISO	12175	5,50 - 8,00	8,0	2-RAD	15,50	22,79	2,23	29,00	15,46	16,45

NOTE 1: Grip range can be affected by parent material density and actual hole size. AVK suggests trial installations to determine optimum grip.
NOTE 2: Additional UNF and UNC threads are available. Contact an AVK Sales Representative for details.
NOTE 3: RN Series threads are not gaugeable after installation.
NOTE 4: Additional grip sizes, materials, head styles and closed end versions are available by special order. Contact an AVK Sales Representative for details.

PART NUMBERING SYSTEM



SAMPLE NUMBER: RNS3T-420-80

RN	()	()	()	()	()
PRODUCT SERIES	MATERIAL	FINISH RoHS COMPLIANT	THREAD CALL OUT	GRIP CALL OUT	TYPE
	CALL OUT GRADE	CALL OUT SPECIFICATION			CALL OUT TYPE
	S Steel C1110/1108	3T ZINC TRIVALENT PER ASTM-B-633, FE/ZN .0003 (8µ)			BLANK Open End
	A Aluminum 6053/5056	4T YELLOW ZINC TRIVALENT PER ASTM-B-633, FE/ZN .0003 (8µ)			B Closed End
	CH Alloy Steel 4037	9T TIN ZINC TRIVALENT PER ESP-P-004, .0003 (8µ)			S Sealed

For air tool



Get quote >>

See Chart on Page 4

Angic Global Solutions

<https://www.AngicGlobal.com> Sales@AngicGlobal.com

1-888-872-0690

27

E-L & E-H METRIC SERIES INSERT PROFILE

The E-L & E-H Metric Series Insert product line offers insert designs to accommodate "true metric" hole sizes. Closed end product and a variety of head configurations are also available. Please contact an AVK Sales Representative for details.

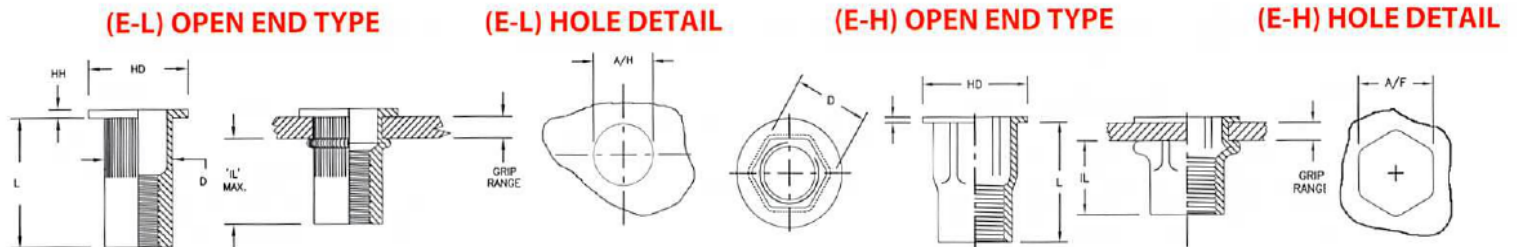

Thread Specifications: Metric 6H/21 per ASME B1.13M

METRIC THREAD SIZES

THREAD SIZE	THREAD CALL OUT	GRIP RANGE	GRIP CALL OUT	A/H HOLE SIZE +0,15 / -0,00	HD ±0,25 ±0,64*	HH ±0,08	L ±0,38	D MAX.	IL MAX.
M4 x 0,7 ISO	470	0,50 - 3,00	3,0	6,0	9,0	1,0	10,3	6,0	5,8
M5 x 0,8 ISO	580	0,50 - 3,00	3,0	7,0	10,0	1,0	12,0	7,0	7,3
M6 x 1,0 ISO	610	0,50 - 3,00	3,0	9,0	13,0	1,5	13,0	9,0	8,0
M6 x 1,0 ISO	610	3,00 - 5,50	5,5	9,0	13,0	1,5	15,7	9,0	8,2
M8 x 1,25 ISO	8125	0,50 - 3,00	3,0	11,0	16,0*	1,5	16,5	11,0	11,0
M8 x 1,25 ISO	8125	3,00 - 5,50	5,5	11,0	16,0*	1,5	19,2	11,0	11,1
M10 x 1,5 ISO	1015	0,70 - 3,50	3,5	13,0	19,0*	2,0	20,0	13,0	13,9

THREAD SIZE	THREAD CALL OUT	GRIP RANGE	GRIP CALL OUT	A/F HOLE SIZE +0,15 / -0,00	HD ±0,25 ±0,64*	HH ±0,08	L ±0,38	D MAX.	IL MAX.
M4 x 0,7 ISO	470	0,50 - 3,00	3,0	6,0	9,0	1,0	10,3	6,0	5,8
M5 x 0,8 ISO	580	0,50 - 3,00	3,0	7,0	10,0	1,0	12,0	7,0	7,3
M6 x 1,0 ISO	610	0,50 - 3,00	3,0	9,0	13,0	1,5	13,0	9,0	8,0
M6 x 1,0 ISO	610	3,00 - 5,50	5,5	9,0	13,0	1,5	15,7	9,0	8,2
M8 x 1,25 ISO	8125	0,50 - 3,00	3,0	11,0	16,0*	1,5	16,5	11,0	11,2
M8 x 1,25 ISO	8125	3,00 - 5,50	5,5	11,0	16,0*	1,5	19,2	11,0	11,2

NOTE 1: Grip range can be affected by parent material density and actual hole size. AVK suggests trial installations to determine optimum grip.
NOTE 2: Closed End Type and special head configurations available. Contact an AVK Sales Representative for details.

PART NUMBERING SYSTEM



SAMPLE NUMBER: ELS3T-610-3,0

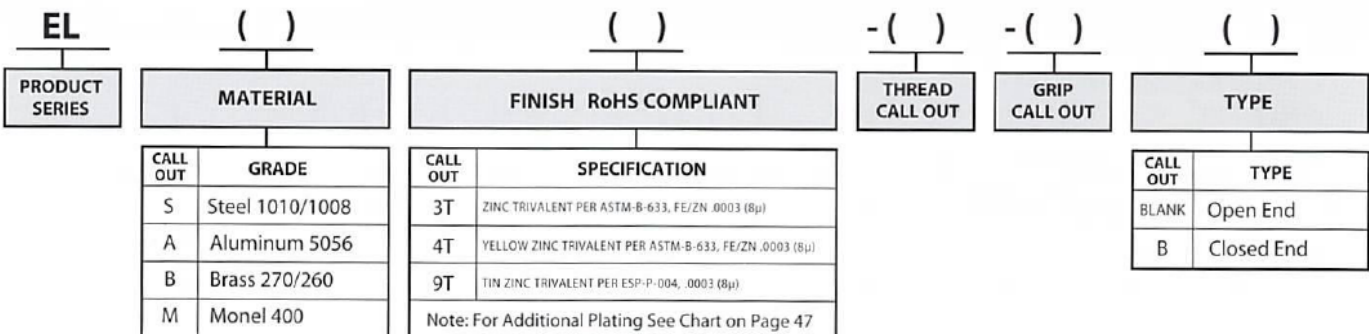

Note: Contact AVK for tool selection.

C-S SERIES INSERT - Patent No. 8,226,339 B2

AVK introduces a new high torque insert for the commercial and industrial markets. The new COMPOSI-SERT™ insert accommodates various grip thicknesses and can be used in a variety of structural materials. Available thread sizes: #10, 1/4, 5/16, M5, M6, M8.



NEW PRODUCTS

C-S SERIES INSERT

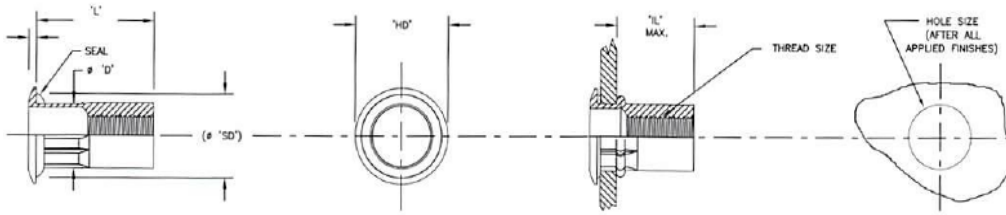

- Various Grip Ranges
- Increased Spin-Out performance over Standard Style Inserts and Rivetnuts.
- Multiple Panel Clamping Capabilities.
- Can be used on a Variety of Structural Materials (including Composite & SMC).
- AVK'S SPPTool™ Systems or Stroke Tools can be used.
- Low Profile Head Style
- Sealed or Non-Sealed Designs



OPEN END TYPE

THREAD SIZE	THREAD CALL OUT	GRIP RANGE	GRIP CALL OUT	HOLE SIZE	HD	HH	L	IL MAX.	SD
M5X0.80	580	0.5-3.5	3.5	7.75-7.60	10.79-10.29	0.84-0.68	12.45-11.69	8.00	10.79
M5X0.80	580	3.0-6.0	6.0	7.75-7.60	10.79-10.29	0.84-0.68	15.24-14.48	8.00	
M5X0.80	580	5.0-8.0	8.0	7.75-7.60	10.79-10.29	0.84-0.68	18.03-17.27	8.00	
M6X1.0	610	0.7-4.0	4.0	10.15-10.00	16.00-15.00	0.84-0.68	15.11-14.35	9.65	16.00
M6X1.0	610	3.5-6.5	6.5	10.15-10.00	16.00-15.00	0.84-0.68	17.65-16.89	9.65	
M6X1.0	610	6.0-9.0	9.0	10.15-10.00	16.00-15.00	0.84-0.68	20.83-20.07	9.65	
M6X1.0	610	7.5-10.5	10.5	10.15-10.00	16.00-15.00	0.84-0.68	24.00-23.24	9.65	22.39
M8X1.25	8125	0.7-3.8	3.8	13.65-13.50	22.39-21.15	0.97-0.81	17.91-17.15	11.94	
M8X1.25	8125	2.5-5.5	5.5	13.65-13.50	22.39-21.15	0.97-0.81	20.83-20.07	10.80	
M8X1.25	8125	5.0-8.0	8.0	13.65-13.50	22.39-21.15	0.97-0.81	25.91-25.15	13.97	22.39
M8X1.25	8125	7.5-10.5	10.5	13.65-13.50	22.39-21.15	0.97-0.81	28.91-28.15	13.97	

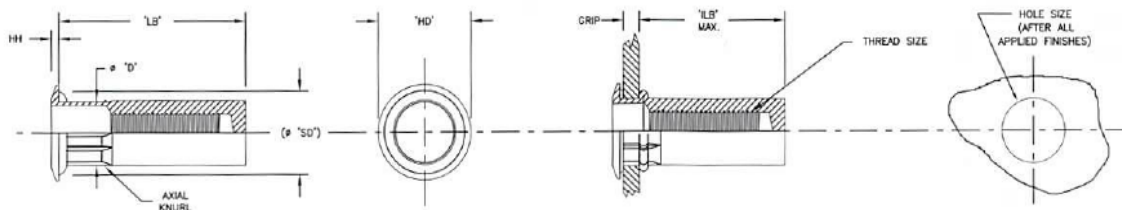

CLOSED END TYPE

THREAD SIZE	THREAD CALL OUT	GRIP RANGE	GRIP CALL OUT	HOLE SIZE	HD	HH	LB MAX	ILB MAX.	SD
M5X0.80	580	0.5-3.5	3.5	7.75-7.60	10.16-9.66	0.84-0.68	28.53-27.77	22.00	10.79
M5X0.80	580	3.0-6.0	6.0	7.75-7.60	10.79-10.29	0.84-0.68	28.53-27.77	22.00	
M5X0.80	580	5.0-8.0	8.0	7.75-7.60	10.79-10.29	0.84-0.68	33.33-32.57	22.00	
M6X1.0	610	0.7-4.0	4.0	10.15-10.00	16.00-15.00	0.84-0.68	30.61-29.85	25.53	16.00
M6X1.0	610	3.5-6.5	6.5	10.15-10.00	16.00-15.00	0.84-0.68	30.61-29.85	22.99	
M6X1.0	610	6.0-9.0	9.0	10.15-10.00	16.00-15.00	0.84-0.68	36.83-36.19	25.53	
M6X1.0	610	8.5-11.5	11.5	10.15-10.00	16.00-15.00	0.84-0.68	36.83-36.19	22.99	22.39
M8X1.25	8125	0.7-3.8	3.8	13.65-13.50	22.39-21.15	0.97-0.81	35.69-34.93	29.85	
M8X1.25	8125	2.5-5.5	5.5	13.65-13.50	22.39-21.15	0.97-0.81	35.69-34.93	26.04	
M8X1.25	8125	5.0-8.0	8.0	13.65-13.50	22.39-21.15	0.97-0.81	41.66-40.89	29.85	22.39
M8X1.25	8125	7.5-10.5	10.5	13.65-13.50	22.39-21.15	0.97-0.81	41.66-40.89	26.04	

PART NUMBERING SYSTEM



SAMPLE NUMBER: CSS4T-610-6.5

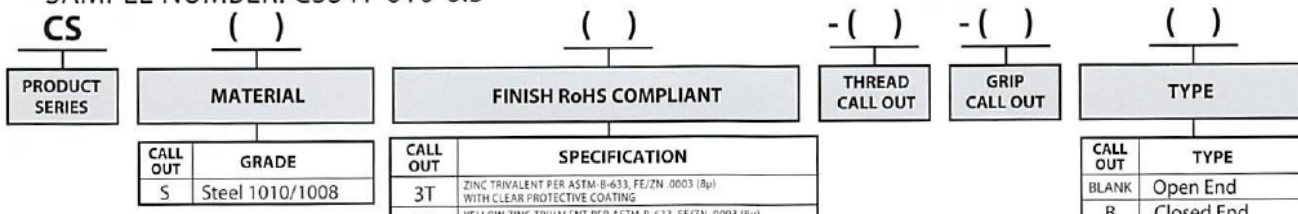

Get quote >>>

Angic Global Solutions

1-888-872-0690

<https://www.AngicGlobal.com>

Sales@AngicGlobal.com



C-L SERIES COMPRESSION LIMITER

**NEW
PRODUCTS**



COMPRESSION

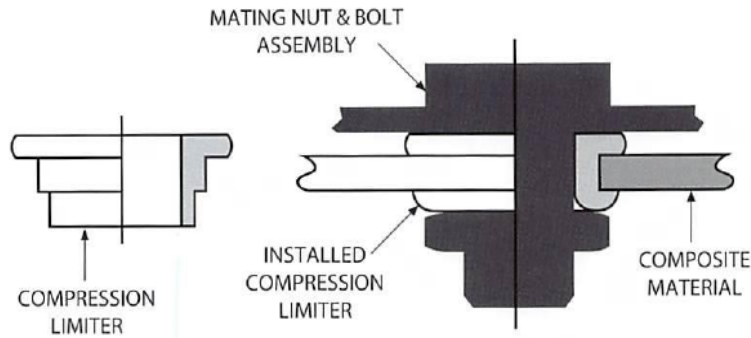

- Compensation for Expansion & Contraction of Composite Material.
- Maintain Joint Stability.
- Protect Composite Material from Damage.
- Reduce Rework from Cracked Assemblies.
- Creates Clean Holes with Alignment Points.
- Reduce Assembly Rejection and Maintain Production Through-Put.
- Excellent for Automotive and Truck Composite Modular Assemblies.



Compression limiters are utilized daily in applications where a compressive load is applied to a composite assembly. The compression limiter distributes and transfers clamp load when the mating bolt or screw is installed into a composite assembly. This distribution of clamp load prevents damage to your assembly and compensates for expansion and contraction of the composite substraight. Thus, the compression limiter will provide consistent joint integrity allowing your joint assembly to remain tight.

Compression limiters are designed specifically for customer's requirements. Simply call your local AVK Sales Representative and provide your requirements.

AVK PNEUMATIC TOOLS PROFILE



AVK has selected the **ARO Brand Pneumatic Tool** for its ergonomic design and outstanding dependability. The rocker style forward and reverse trigger is easy and comfortable to use.

The AVK pneumatic tool features a Quick-Change thread adaption kit. This patented* feature allows for easy access to the thread size component parts. AVK's Pneumatic tools provide the highest RPM for the thread size selected resulting in optimum installation speed.



THREAD ADAPTION KIT



*Patent No. 4,121,444

HOW THE AVK TOOL WORKS

- The operator quarter turns an AVK threaded insert onto the tool mandrel and places it into the hole in the parent material.
- The top trigger is depressed and the tool mandrel spins into the insert.
- The head of the threaded insert is gripped by the knurling at the nose piece preventing it from spinning as the threaded area of the insert "walks" up the mandrel.
- As this occurs, the AVK insert expands within the hole wall providing hole fill and then forms a secondary flange against the backside of the parent material.
- The tool continues to torque the insert's threads causing the knurling to bite into the backside edge of the parent material.
- The tool then stalls when it reaches its predetermined stall torque. This occurs even if the parent material varies in thickness. The tool needs no adjustment to install AVK's products in variable thickness materials.
- The operator then presses the lower reverse trigger and the mandrel spins out of the installed part.

DESIGN BENEFITS

- The AVK ARO tool uses torque to install the AVK product. It needs no adjustment to install the product in variable thickness material.
- The ergonomic design of the AVK ARO tool makes it feel comfortable to the operator and weighs in at 3 lbs. (1.36 kg).
- The rocker style trigger is easy to use & minimizes operator fatigue.
- The knurled nose assembly eliminates any torque "kick" during installation.
- Preventative maintenance is quick and easy with AVK's patented* quick-change thread adaption kit. No tools are required.
- The rugged design of the tool casing, its components and the AVK thread adaption kit provides you with reliability.

ADDITIONAL DESIGN TYPES

SPECIAL DESIGNS

AVK can design a thread adaption kit nose assembly to fit your particular application needs.



RIGHT ANGLE DESIGN

The Right Angle Inline Style Tool is designed for limited access applications.



HEAD FORMING THREAD ADAPTION KIT

A Head Forming T.A.K. is available to contour the AVK insert's head to the radius of a tube to increase torque capability.



INLINE DESIGN

The Inline Style Tool is designed for vertical installations.



Get quote >>

Angic Global Solutions

<https://www.AngicGlobal.com> Sales@AngicGlobal.com

1-888-872-0690

31



AVK PNEUMATIC TOOL SPECIFICATIONS

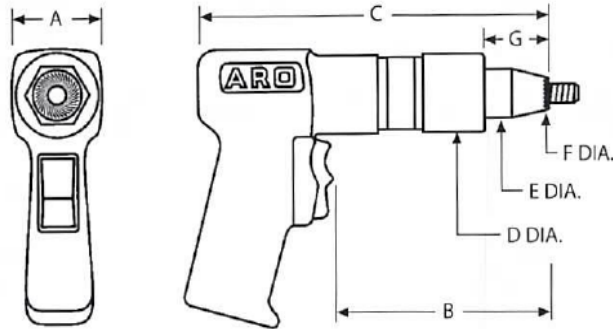

The tool shown on this page has been specifically designed to install the A-L, A-K, A-H, A-P and A-O Series Inserts.

Once you have selected the type of insert and thread size required for your application, select the appropriate RPM tool from the chart below.

DIMENSIONAL DATA / TOOL SET-UP REQUIREMENTS

RPM	WEIGHT LBS. (Kg)	A	B	C	D DIA.	E DIA.	F DIA. MAX.	G
3,000	2.55 (1.15)	1.86 (47,24)	4.75 (120,6)	7.75 (196,8)	1.57 (39,87)	1.00 (25,40)	.400 (10,16)	1.3 (33,0)
1,500	2.58 (1.17)	1.86 (47,24)	4.75 (120,6)	7.75 (196,8)	1.57 (39,87)	1.00 (25,40)	.400 (10,16)	1.3 (33,0)
900	3.18 (1.44)	1.86 (47,24)	6.00 (152,4)	9.00 (228,6)	1.57 (39,87)	1.00 (25,40)	.500 (12,7)	1.3 (33,0)
600	3.18 (1.44)	1.86 (47,24)	6.00 (152,4)	9.00 (228,6)	1.57 (39,87)	1.00 (25,40)	.640 (16,25)	1.3 (33,0)
350	3.25 (1.46)	1.86 (47,24)	5.37 (136,3)	8.37 (212,5)	1.50 (38,10)	1.42 (36,06)	.900 (22,86)	NA (NA)

PROPER AIR SUPPLY SET-UP REQUIRES:

- 90-110 PSI (6.2-7.5 BARS) dynamic (tool running) air pressure at 25 S.C.F.M.
- Inline oiler/separator
- Air pressure gauge and regulator
- 5/16 or 7,92 mm minimum hose ID
- 5/16 or 7,92 mm minimum fittings ID

SPECIAL FEATURE—The AKPT nose cone design incorporates a special pilot/serrated tip that is essential to proper insert installation. The "A-K" prefix in the tool part number designates this feature

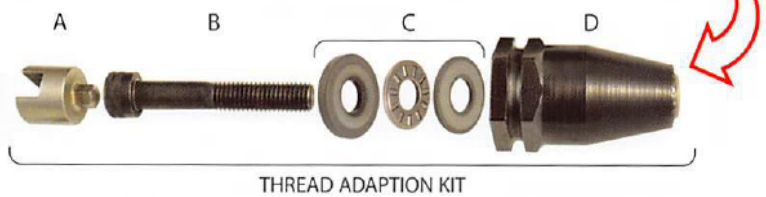

AIR TOOL SELECTION / SPARE PARTS

THREAD SIZE	TOOL R.P.M	COMPLETE TOOL PART NUMBER	THREAD ADAPTION KIT	A HEX DRIVE	B MANDREL 10 PER BAG	C BEARING SET	D NOSE CONE	DYNAMIC AIR PRESSURE SETTINGS PSI - BARS
6-32 UNC	3000	AKPT30P632	AKPT632TAK	29NPT22	B3SH632-1500	32PT1	77AKPT6	70 - 80
8-32 UNC	3000	AKPT30P832	AKPT832TAK	29NPT23	B3SH832-1500	32PT2	77AKPT8	75 - 90
10-24 UNC	1500	AKPT15P1024	AKPT1024TAK	29NPT4	B3SH1024-1750	32PT4	77AKPT10	60 - 80
10-32 UNF	1500	AKPT15P1032	AKPT1032TAK	29NPT4	B3SH1032-1750	32PT4	77AKPT10	60 - 80
1/4-20 UNC	900	AKPT9P420	AKPT420TAK	29NPT5	B3SH420-1500	32PT5	77AKPT250	70 - 90
5/16-18 UNC	600	AKPT6P518	AKPT518TAK	29NPT6	B3SH518-2250	32PT7	77AKPT3125	80 - 110
3/8-16 UNC	600	AKPT6P616	AKPT616TAK	29NPT7	B3SH616-2250	32PT8	77AKPT375	80 - 110
1/2-13 UNC	350	AKPT3P813	AKPT813CTA	29NPT26	B3SH813-2500	30NPT500	77AKPT500	80 - 110
M4 x 0,7 ISO	3000	AKPT30P470	AKPT470TAK	29NPT24	B3SH470-40	32PT3	77AKPT470	4.8 - 5.5
M5 x 0,8 ISO	1500	AKPT15P580	AKPT580TAK	29NPT10	B3SH580-45	32PT4	77AKPT580	4.1 - 5.5
M6 x 1,0 ISO	900	AKPT9P610	AKPT610TAK	29NPT11	B3SH610-40	32PT6	77AKPT610	4.8 - 6.2
M8 x 1,25 ISO	600	AKPT6P8125	AKPT8125TAK	29NPT12	B3SH8125-55	32PT7	77AKPT8125	5.5 - 7.5
M10 x 1,50 ISO	600	AKPT6P1015	AKPT1015TAK	29NPT25	B3SH1015-55	32PT10	77AKPT1015	5.5 - 7.5
M12 x 1,75 ISO	350	AKPT3P12175	AKPT12175CTA	29NPT27	B3SH12175-60	30NPT500	77AKPT12175	5.5 - 7.5

This chart designates the tool, spare parts and dynamic (tool running) air pressure requirements for our most popular steel product. Consult the AVK tool catalog or contact an AVK Sales Representative for tool RPM and air pressure settings for aluminum, brass and monel product.

NOTE: UNF FINE THREAD COMPONENTS ARE AVAILABLE.

PREVENTATIVE MAINTENANCE REQUIREMENTS:

- The bearing set must be kept in a WET lubricated condition to assure proper tool operation. AVK suggests the use of high temperature grease such as LUBRIPLATE® BRAND 930 AA.
- The tool mandrel should be inspected for thread wear or damage and replaced. To test the condition of the mandrel, thread an AVK insert onto the mandrel backwards until it touches the pilot. If any drag is still felt, replace the mandrel with a new socket head cap screw.



AVK PNEUMATIC TOOL SPECIFICATIONS



PNEUMATIC TOOLS

The tool shown on this page has been specifically designed to install the A-T, A-W, Series Inserts.

Once you have selected the type of insert and thread size required for your application, select the appropriate RPM tool from the chart below.

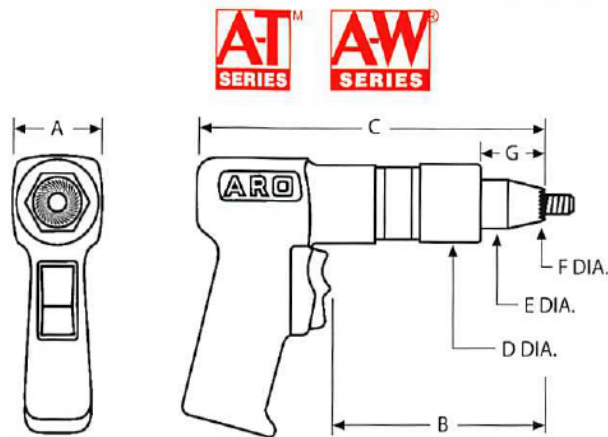

DIMENSIONAL DATA / TOOL SET-UP REQUIREMENTS

PROPER AIR SUPPLY SET-UP REQUIRES:

- 90-110 PSI (6.2-7.5 BARS) dynamic (tool running) air pressure at 25 S.C.F.M.
- Inline oiler/separator
- Air pressure gauge and regulator
- 5/16 or 7,92 mm minimum hose ID
- 5/16 or 7,92 mm minimum fittings ID

RPM	WEIGHT LBS. (Kg)	A	B	C	D DIA.	E DIA.	F DIA. MAX.	G
3,000	2.55 (1.15)	1.86 (47,24)	4.75 (120,6)	7.75 (196,8)	1.57 (39,87)	1.00 (25,40)	.350 (8,89)	1.3 (33,0)
	2.58 (1.17)	1.86 (47,24)	4.75 (120,6)	7.75 (196,8)	1.57 (39,87)	1.00 (25,40)	.600 (15,24)	1.3 (33,0)
1,500	3.18 (1.44)	1.86 (47,24)	6.00 (152,4)	9.00 (228,6)	1.57 (39,87)	1.00 (25,40)	.625 (15,87)	1.3 (33,0)
	3.25 (1.46)	1.86 (47,24)	6.00 (152,4)	8.37 (212,5)	1.50 (38,10)	1.43 (36,32)	.900 (22,86)	NA (NA)

SPECIAL FEATURE—The NPT nose cone design incorporates a special serrated tip that is essential to proper insert installation. The "N" prefix in the tool part no. designates this feature.



AIR TOOL SELECTION / SPARE PARTS

THREAD SIZE	TOOL R.P.M	COMPLETE TOOL PART NUMBER	THREAD ADAPTION KIT	A HEX DRIVE	B MANDREL 10 PER BAG	C BEARING SET	D NOSE CONE	DYNAMIC AIR PRESSURE SETTINGS PSI - BARS
4-40 UNC	3000	NPT30P440	NPT440TAK	29NPT1	B3SH400-750	30NPT4	77NPT4	36 - 40
6-32 UNC	3000	NPT30P632	NPT632TAK	29NPT2	B3SH632-875	30NPT6	77NPT6	70 - 80
8-32 UNC	3000	NPT30P832	NPT832TAK	29NPT3	B3SH832-875	30NPT8	77NPT8	60 - 85
10-24 UNC	1500	NPT15P1024	NPT1024TAK	29NPT4	B3SH1024-1500	30NPT10	77NPT10	60 - 85
10-32 UNF	1500	NPT15P1032	NPT1032TAK	29NPT4	B3SH1032-1500	30NPT10	77NPT10	60 - 85
1/4-20 UNC	1500	NPT15P420	NPT420TAK	29NPT5	B3SH420-1250	30NPT250	77NPT250	70 - 95
5/16-18 UNC	600	NPT6P518	NPT518TAK	29NPT6	B3SH518-1750	30NPT3125	77NPT3125	80 - 100
3/8-16 UNC	600	NPT6P616	NPT616TAK	29NPT7	B3SH616-1750	30NPT375	77NPT375	90 - 110
1/2-13 UNC	350	NPT3P813	NPT813CTA	29NPT26	B3SH813-2000	30NPT500	77NPT500	95 - 110
M3 x 0,5 ISO	3000	NPT30P350	NPT350TAK	29NPT8	B3SH350-20	30NPTM3	77NPTM3	2.4 - 2.7
M4 x 0,7 ISO	3000	NPT30P470	NPT470TAK	29NPT9	B3SH470-20	30NPTM4	77NPTM4	4.1 - 5.5
M5 x 0,8 ISO	1500	NPT15P580	NPT580TAK	29NPT10	B3SH580-40	30NPTM5	77NPTM5	4.1 - 5.5
M6 x 1,0 ISO	1500	NPT15P610	NPT610TAK	29NPT11	B3SH610-35	30NPTM6	77NPTM6	4.8 - 6.5
M8 x 1,25 ISO	600	NPT6P8125	NPT8125TAK	29NPT12	B3SH8125-45	30NPTM8	77NPTM8	5.5 - 6.8
M10 x 1,50 ISO	600	NPT6P1015	NPT1015TAK	29NPT25	B3SH1015-45	32PT10	77NPT1015	6.2 - 7.5
M12 x 1,75 ISO	350	NPT3P12175	NPT12175CTA	29NPT27	B3SH12175-50	30NPT500	77NPTM12	6.2 - 7.5

This chart designates the tool, spare parts and dynamic (tool running) air pressure requirements for our most popular steel product. Consult the AVK tool catalog or contact an AVK Sales Representative for tool RPM and air pressure settings for aluminum, brass and stainless product.

NOTE: UNF FINE THREAD COMPONENTS ARE AVAILABLE.

PREVENTATIVE MAINTENANCE REQUIREMENTS:

- The bearing set must be kept in a WET lubricated condition to assure proper tool operation. AVK suggests the use of high temperature grease such as LUBRIPLATE® BRAND 930 AA.
- The tool mandrel should be inspected for thread wear or damage and replaced. To test the condition of the mandrel, thread an AVK insert onto the mandrel backwards until it touches the knurled nose cone. If any drag is still felt, replace the mandrel with a new socket head cap screw.



Get quote >>

Angic Global Solutions

1-888-872-0690

33

<https://www.AngicGlobal.com> Sales@AngicGlobal.com

AVK PNEUMATIC TOOL SPECIFICATIONS

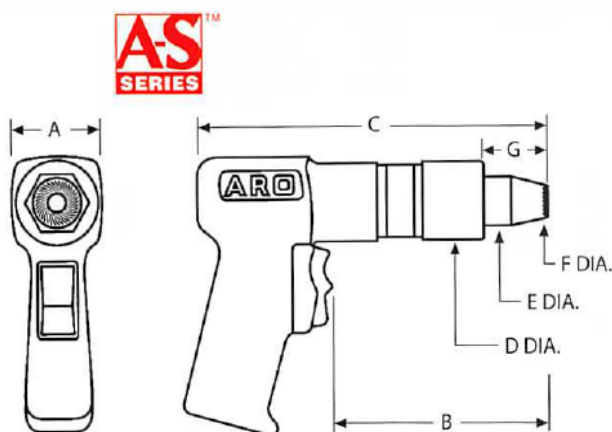

The tool shown on this page has been specifically designed to install the A-S Series Stud.

Once you have selected the type of stud and thread size required for your application, refer to the chart below for air tool selection.

DIMENSIONAL DATA / TOOL SET-UP REQUIREMENTS

RPM	WEIGHT LBS. (Kg)	A	B	C	D DIA.	E DIA.	F DIA. MAX.	G
3,000	2.55 (1.15)	1.86 (47,24)	4.75 (120,6)	7.75 (196,85)	1.57 (39,87)	1.00 (25,40)	.400 (10,16)	1.3 (33,0)
1,500	2.58 (1.17)	1.86 (47,24)	4.75 (120,6)	7.75 (196,85)	1.57 (39,87)	1.00 (25,40)	.400 (10,16)	1.3 (33,0)
900	3.18 (1.44)	1.86 (47,24)	6.00 (152,4)	9.00 (228,6)	1.57 (39,87)	1.00 (25,40)	.500 (12,7)	1.3 (33,0)
600	3.18 (1.44)	1.86 (47,24)	6.00 (152,4)	8.37 (212,6)	1.57 (39,87)	1.00 (25,40)	.640 (16,25)	1.3 (33,0)

PROPER AIR SUPPLY SET-UP REQUIRES:

- 90-110 PSI (6.2-7.5 BARS) dynamic (tool running) air pressure at 25 S.C.F.M.
- Inline oiler/separator
- Air pressure gauge and regulator
- 5/16 or 7,92 mm minimum hose ID
- 5/16 or 7,92 mm minimum fittings ID

SPECIAL FEATURE—This tool nose cone design incorporates a special serrated tip that is essential to proper installation.



THREAD ADAPTION KIT

AIR TOOL SELECTION / SPARE PARTS

THREAD SIZE	TOOL R.P.M	COMPLETE TOOL PART NUMBER	THREAD ADAPTION KIT	A THREAD DRIVE	C BEARING SET	D NOSE CONE	DYNAMIC AIR PRESSURE SETTINGS PSI - BARS
6-32 UNC	3000	ASPT30P632	ASPT632TAK	29ASPT632	32PT5	77ASPT8	70 - 80
8-32 UNC	3000	ASPT30P832	ASPT832TAK	29ASPT832	32PT5	77ASPT8	75 - 90
10-24 UNC	1500	ASPT15P1024	ASPT1024TAK	29ASPT1024	32PT12	77ASPT10	60 - 80
10-32 UNF	1500	ASPT15P1032	ASPT1032TAK	29ASPT1032	32PT12	77ASPT10	60 - 80
1/4-20 UNC	900	ASPT9P420	ASPT420TAK	29ASPT420	32PT8	77ASPT4	70 - 90
5/16-18 UNC	600	ASPT6P518	ASPT518CTA	29ASPT518	30NPT500	77ASPT8125	80 - 110
3/8-16 UNC	600	ASPT6P616	ASPT616CTA	29ASPT616	30NPT500	77ASPT8125	80 - 110
M4 x 0,7 ISO	3000	ASPT30P470	ASPT470TAK	29ASPT470	32PT5	77ASPT8	4.8 - 5.5
M5 x 0,8 ISO	1500	ASPT15P580	ASPT580TAK	29ASPT580	32PT12	77ASPT10	4.1 - 5.5
M6 x 1,0 ISO	900	ASPT9P610	ASPT610TAK	29ASPT610	32PT8	77ASPT4	5.5 - 6.2
M8 x 1,25 ISO	600	ASPT6P8125	ASPT8125CTA	29ASPT8125	30NPT500	77ASPT8125	5.5 - 7.5
M10 x 1,50 ISO	600	ASPT6P1015	ASPT1015CTA	29ASPT1015	30NPT500	77ASPT8125	5.5 - 7.5

NOTE: Air pressure settings are specified dynamic (tool running).

PREVENTATIVE MAINTENANCE REQUIREMENTS:

- The bearing set must be kept in a WET lubricated condition to assure proper tool operation. AVK suggests the use of high temperature grease such as LUBRIPLATE® BRAND 930 AA.

AVK PNEUMATIC TOOL SPECIFICATIONS



PNEUMATIC TOOLS

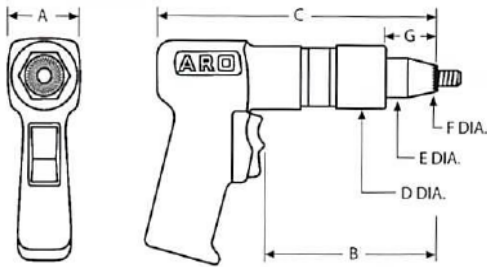

The tool shown on this page has been specifically designed to install the A-R Series Inserts.

AVK recommends that trial installations be performed to determine the optimum tool for the fastener selected using actual application materials and hole sizes. Tool RPM and parent material density will affect the grip range of the fastener. See the chart below for guidelines.

DIMENSIONAL DATA / TOOL SET-UP REQUIREMENTS

PROPER AIR SUPPLY SET-UP REQUIRES:

- 90-110 PSI (6.2-7.5 BARS) dynamic (tool running) air pressure at 25 S.C.F.M.
- Inline oiler/separator
- Air pressure gauge and regulator
- 5/16 or 7,92 mm minimum hose ID
- 5/16 or 7,92 mm minimum fittings ID

RPM	WEIGHT LBS. (Kg)	A	B	C	D DIA.	E DIA.	F DIA. MAX.	G
1,500	2.58	1.86	4.75	7.75	1.57	1.00	.400	1.3
	(1.17)	(47,24)	(120,6)	(196,8)	(39,87)	(25,40)	(10,16)	(33,0)
900	3.18	1.86	6.00	9.00	1.57	1.00	.500	1.3
	(1.44)	(47,24)	(152,4)	(228,6)	(39,87)	(25,40)	(12,70)	(33,0)

SPECIAL FEATURE—The NPT nose cone design incorporates a special serrated tip that is essential to proper insert installation. The "N" prefix in the tool part number designates this feature.

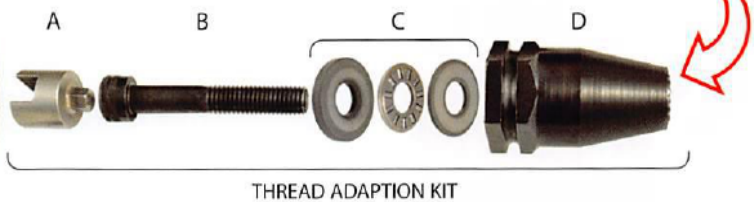
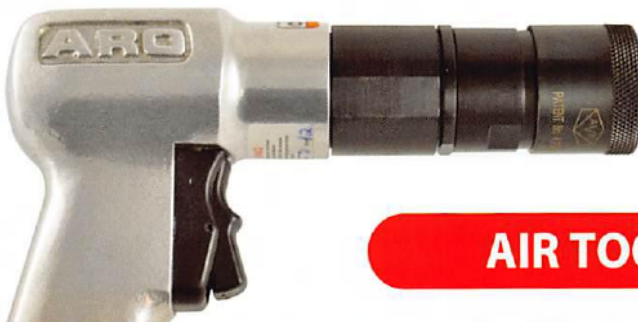

AIR TOOL SELECTION / SPARE PARTS

AVK PART NUMBER	TOOL R.P.M	PARENT MATERIAL		COMPLETE TOOL PART NUMBER	THREAD ADAPTION KIT	A HEX DRIVE	B SCREW MANDREL	C BEARING SET	D NOSE CONE	DYNAMIC AIR PRESSURE SETTINGS PSI - BARS
		STEEL, ALUMINUM FIBERGLASS SML	BLOW, ROTATIONAL SOFT PLASTICS							
ARS4T-420-280	1500	.020 - .190	.020 - .250	ARPT15P420-280	ARPT420-280TAK	29NPT5	3SH420-2000	32PT5	77NPT250	60 - 70
	900	.020 - .250	.020 - .250	ARPT9P420-280						40 - 60
ARS4T-420-500	1500	.250 - .430	.250 - .470	ARPT15P420-500	ARPT420-500TAK	29NPT5	3SH420-2250	32PT5	77NPT250	60 - 70
	900	.250 - .470	.250 - .470	ARPT9P420-500						40 - 60
ARS4T-518-280	900	.020 - .260	-	ARPT9P518-280	ARPT518-280TAK	29NPT6	3SH518-2500	32PT12	77NPT3125	70 - 90
	-	-	-	-						-
ARS4T-518-500	900	.280 - .480	-	ARPT9P518-500	ARPT518-500TAK	29NPT6	3SH518-2750	32PT12	77NPT3125	70 - 90
	-	-	-	-						-
ARS4T-616-280	600	.020 - .260	-	ARPT6P616-280	ARPT616-280TAK	29NPT7	3SH616-2500	32PT8	77NPT375	70 - 90
ARS4T-616-500	600	.280-480	-	ARPT6P616-500	ARPT616-500TAK	29NPT7	3SH616-2750	32PT8	77NPT375	-
ARS4T-610-7.1	1500	0.5 - 4.8	0.5 - 6.3	ARPT15P610-7.1	ARPT610-7.1TAK	29NPT11	3SH610-50	32PT6	77NPTM6	4.1 - 4.8
	900	0.5 - 6.3	0.5 - 6.3	ARPT9P610-7.1						2.8 - 4.1
ARS4T-610-12.7	1500	6.3 - 10.9	6.3 - 11.9	ARPT15P610-12.7	ARPT610-12.7TAK	29NPT11	3SH610-55	32PT6	77NPTM6	4.1 - 4.8
	900	6.3 - 11.9	6.3 - 11.9	ARPT9P610-12.7						2.8 - 4.1
ARS4T-8125-7.1	900	0.5 - 6.6	0.5 - 6.6	ARPT9P8125-7.1	ARPT8125-7.1TAK	29NPT12	3SH8125-60	32PT7	77NPTM8	4.8 - 6.2
	-	-	-	-						-
ARS4T-8125-12.7	900	7.1 - 12.2	-	ARPT9P8125-12.7	ARPT8125-12.7TAK	29NPT12	3SH8125-65	32PT7	77NPTM8	4.8 - 6.2
	-	-	-	-						-
ARS4T-1015-7.1	600	0.5 - 6.6	-	ARPT6P1015-7.1	ARPT1015-7.1TAK	29NPT25	3SH1015-60	32PT10	77NPT1015	4.8 - 6.2
	-	-	-	-						-
ARS4T-1015-12.7	600	7.1-12.2	-	ARPT6P1015-12.7			3SH1015-65			-

NOTE: UNF FINE THREAD COMPONENTS ARE AVAILABLE.

PREVENTATIVE MAINTENANCE REQUIREMENTS:

- The bearing set must be kept in a WET lubricated condition to assure proper tool operation. AVK suggests the use of high temperature grease such as LUBRIPLATE® BRAND 930 AA.
- The tool mandrel should be inspected for thread wear or damage and replaced. To test the condition of the mandrel, thread an AVK insert onto the mandrel backwards until the tool will not turn. If you feel resistance, replace the mandrel with a new socket head cap screw.



Get quote >>

Angic Global Solutions

1-888-872-0690

<https://www.AngicGlobal.com> Sales@AngicGlobal.com

35



PNEUMATIC TOOLS

AVK OST™ PNEUMATIC RAPID INSERT TOOL - AVK5500

Time is money; and to reduce your installation cost with a rapid sure shot installation tool, AVK is pleased to introduce the AVK One-Set™ Tool (OST™) insert installation system. Our OST™ is a multi-stroke and pull to pressure insert tool designed to meet any installation criteria.

OST™ is a light weight 5.3 pound ergonomic installation tool allowing you to select your Placement Method, Stroke or Pressure. Combined with a push to start threading system, and single trigger installation, this tool will offer a new standard in fast and easy insert installation for your product assembly.

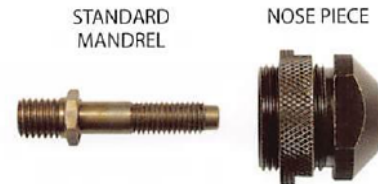

STANDARD THREAD CONVERSION KIT

AIR TOOL SELECTION / SPARE PARTS

AVK5500 THREAD CONVERSION KITS

THREAD SIZE	AL, AK, AH, AO STANDARD CONVERSION KIT	AT*, RN* CONVERSION KIT	MANDREL	AL, AK, AH, AO NOSE PIECE	AT*, RN* NOSE PIECE
6-32 UNC	5500-AL632TAK	5500-RN632TAK	18AVK5500-AL632	77AVK5500-AL632	77AVK5500-RN632
8-32 UNC	5500-AL832TAK	5500-RN832TAK	18AVK5500-AL832	77AVK5500-AL832	77AVK5500-RN832
10-24 UNC	5500-AL1024TAK	5500-RN1024TAK	18AVK5500-AL1024	77AVK5500-AL1024	77AVK5500-RN1024
10-32 UNF	5500-AL1032TAK	5500-RN1032TAK	18AVK5500-AL1032	77AVK5500-AL1032	77AVK5500-RN1032
1/4-20 UNC	5500-AL420TAK	5500-RN420TAK	18AVK5500-AL420	77AVK5500-AL420	77AVK5500-RN420
1/4-28 UNF	5500-AL428TAK	5500-RN428TAK	18AVK5500-AL428	77AVK5500-AL428	77AVK5500-RN428
5/16-18 UNC	5500-AL518TAK	5500-RN518TAK	18AVK5500-AL518	77AVK5500-AL518	77AVK5500-RN518
5/16-24 UNC	5500-AL524TAK	5500-RN524TAK	18AVK5500-AL524	77AVK5500-AL524	77AVK5500-RN524
3/8-16 UNC	5500-AL616TAK	5500-RN616TAK	18AVK5500-AL616	77AVK5500-AL616	77AVK5500-RN616
3/8-24 UNF	5500-AL624TAK	5500-RN624TAK	18AVK5500-AL624	77AVK5500-AL624	77AVK5500-RN624
1/2-13 UNC	5500-AL813TAK	See Note Below*	18AVK5500-AL813	77AVK5500-AL813	See Note Below*
M4 x 0,7 ISO	5500-AL470TAK	5500-RN470TAK	18AVK5500-AL470	77AVK5500-AL470	77AVK5500-RN470
M5 x 0,8 ISO	5500-AL580TAK	5500-RN580TAK	18AVK5500-AL580	77AVK5500-AL580	77AVK5500-RN580
M6 x 1,0 ISO	5500-AL610TAK	5500-RN610TAK	18AVK5500-AL610	77AVK5500-AL610	77AVK5500-RN610
M8 x 1,25 ISO	5500-AL8125TAK	5500-RN8125TAK	18AVK5500-AL8125	77AVK5500-AL8125	77AVK5500-RN8125
M10 x 1,50 ISO	5500-AL1015TAK	5500-RN1015TAK	18AVK5500-AL1015	77AVK5500-AL1015	77AVK5500-RN1015
M12 x 1,75 ISO	5500-AL12175TAK	See Note Below*	18AVK5500-AL12175	77AVK5500-AL12175	See Note Below*

FEATURES

- Dual Installation system - Traction (Pull to Pressure) & Stroke (Set stroke length).
- 5.7 Bars or 82 PSI air pressure requirement.
- Will set M3-M12 and 6-32 to 1/2-13 inserts*.
- Ergonomic, light weight and well balanced at 2.4kg or 5.3 pounds.
- Durable impact resistance composite body reinforced with steel frame.
- Automatic insert mandrel feed by depressing the insert onto the mandrel.
- Single trigger installation sequence.
- And of course, rapid insert installation by way of our 10mm/.390 stroke.

*Note: AVK's One-Set™ Tool will not set the RN or AT Series in the 1/2-13 and M12 x 1,75 sizes.

PART NUMBERING SYSTEM

SAMPLE NUMBER: AVK5500-AL420

AVK5500-

BASE TOOL PART NO.

()

STYLE: AL or RN

()

THREAD SIZE: Example 420

()

TYPE: Blank = Standard Conversion Kit

NEW SPP2 TOOL™ SYSTEM INTRODUCTION



The New Modularized **SPP2 Tool™ System** has been designed exclusively to install AVK's complete line of blind installed fasteners. The term SPP2 Tool™ stands for Spin Pull to Pressure. The SPP2 Tool™ spins into the AVK fastener, automatically pulling the fasteners into a proper installation utilizing pressure as the upset control method. Pulling to pressure insures the AVK fastener will be installed correctly into single, multiple or variable thickness materials without adjustment.

THE TOOL SYSTEM FEATURES

- The Power Pack contains the air over hydraulic power system. The Power Pack is capable of providing 7,500 lbs. of pulling force enabling the tool to install any AVK product in any thread size up to 1/2" and M12. Combined with a NEW Pneumatic-Hydraulic Boost System providing a 15% to 20% faster cycle time for rapid installation.
- The all new SPP2 Tool™ comes furnished with attached tool hangers, casters and durable air and hydraulic quick release fittings allowing the operator to pull the unit along the work floor.
- The Power Pack can be adjusted to pull any AVK fastener with the simple adjustment of an air pressure regulator. Our new robust design features a see through glass hydraulic fluid reservoir for visual inspection of the hydraulic fluid level, enabling quick and easy adjustments.
- The SPP2 Tool™ is lightweight and ergonomically designed. It features a rocker style trigger and a high speed motor that provides the quickest spin-in / spin-out of any tool on the market. The tool also has a patented quick release thread adaptation kit that makes thread size changes quick and easy with no wrenches required.

NEW SPP3 TOOL™ DATA MASTER

- AVK is committed to superior quality, reducing rework cost, and providing optimal joint integrity for our customer's assemblies. With joint integrity in mind, AVK is pleased to introduce our SPP3 Tool™ Data Master PLC Linked Installation Tool System.
- AVK's Data Master will analyze every insert installation by virtue of the on board PLC. The Data Master Pistol sets the insert and transmits air pressure signals to the PLC and converts that into usable installation verification information. This data appears on the systems computer screen as a good or faulty installation. The data is stored and collected for current and future evaluation to substantiate proper insert placement, indicating correct product assembly installation.
- AVK's Data Master houses a redesigned space saving SPP3 Tool™ Power pack which is connected to the SPP3 Tool™ Pistol and linked to our on board PLC. Our Data Master collects data for SPC Analysis that you have set pertaining to your installation requirements and captures that data by using a standard spreadsheet software program. For installation verification for your company or customer's assemblies, please consider the AVK SPP3 Tool™ Data Master for secure joint integrity!



Get quote »

Angic Global Solutions

<https://www.AngicGlobal.com> Sales@AngicGlobal.com

1-888-872-0690

37



AVK SPP2 TOOL™ TOOL SPECIFICATIONS

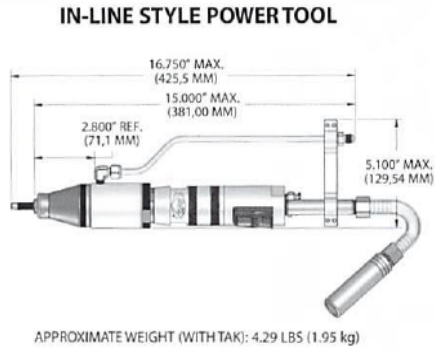
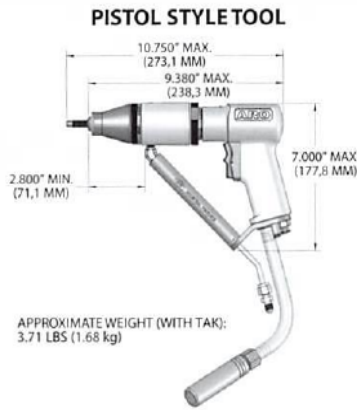

The SPP2 Tool™ hose assembly is available in 6', 8', 10', and 15' lengths. Hose weight 6'= 1.1 lbs., 8'= 1.32 lbs., 10'= 1.51 lbs., 15'= 2.0 lbs.

POWER CONTROL SYSTEM DIMENSIONS

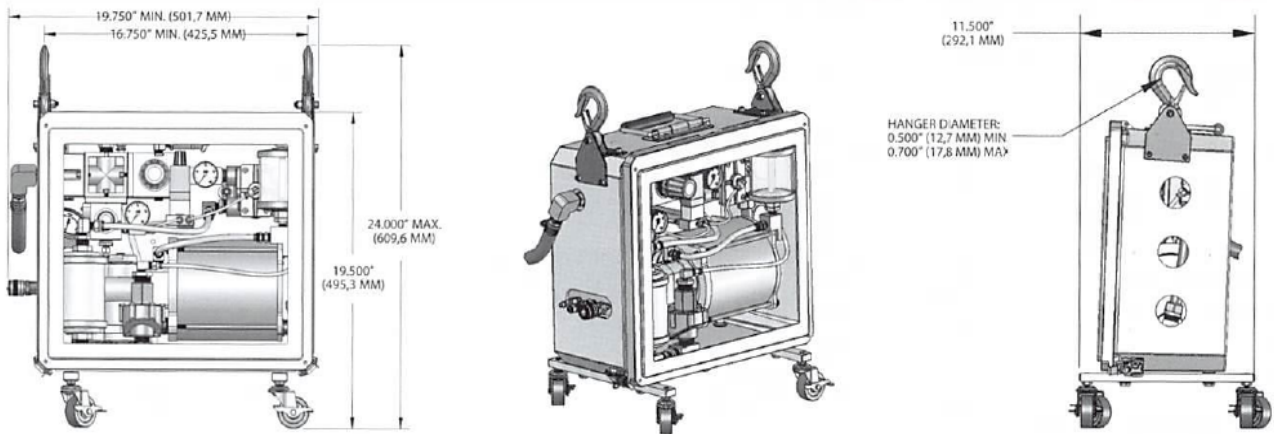

The hydraulic pull force capability of the SPP2 Tool™ is 7,500 lbs. max (35.6 kN) at 80 psi. Air pressure requirement to the power control system is 90 psi dynamic (6.2 bars).

PRODUCT / TOOL SELECTION

Product tool section added note: SPP2 Tool™ per the part numbers below will be supplied with mandrels to install 1st and 2nd grip fasteners. If longer grip fasteners are being used contact AVK for appropriate mandrel part numbers.

PRODUCT SERIES	THREAD SIZE	STEEL	BRASS	ALUMINUM	MONEL	STAINLESS STEEL
A-K, A-L	#6-1/2 M4-M12	✓	✓	✓	✓	N/A
A-H	#6-1/2 M4-M12	✓	✓	✓	✓	✓
A-S	#6-3/8 M4-M10	✓	N/A	N/A	N/A	N/A
A-R	1/4-3/8 M6-M10	✓	N/A	N/A	N/A	N/A
A-T	#4-1/2 M3-M12	✓	✓	✓	✓	✓
A-W	#6-3/8 M4-M10	✓	✓	N/A	N/A	N/A
A-O	#6-3/8 M4-M10	✓	N/A	N/A	✓	N/A
R-N	#4-1/2 M3-M12	✓	N/A	✓	N/A	✓ (up to 3/8 & M10)

NOTE: See SPP2 Tool™ manual for set up, spare parts and preventative maintenance.

SAMPLE NUMBER: SPP2P8AL420

SPP2		()	()	()	()	()		
SYSTEM TYPE	CALL OUT	TOOL TYPE	CALL OUT	HOSE LENGTH	POWER CONTROL TYPE	CALL OUT	SERIES	AVK THREAD SIZE CALL OUT
	P	Pistol	6	6 Feet		AL	A-L, A-K, A-H, A-O	
	IL	In Line	8	8 Feet		AR	A-R	
			10	10 Feet		RN	R-N, A-T, A-W	
	MP	Mini Pistol	15	15 Feet		AS	A-S	



AVK PORTABLE BATTERY POWER TOOL - AVK4878



PORTABLE TOOLS

Portable Battery Power at your finger tips for Ease of Installation and Ergonomic comfort! Worldwide first completely Electronic Power controlled Battery tool for the installation of High-Torque Blind Rivet Nuts and Blind Rivet Studs

- Electronic Process Control ensures a stable and consistent installation.
- Spin-Spin installation without adjustment on different material thicknesses.
- Easy to handle, simple adjustment.
- High Process Security.
- Suitable for High-Torque Steel Inserts M4 - M10/#6 - 3/8" and Studs M4 - M6/#6 - 1/4".



SPECIAL FEATURE—This tool nose cone design incorporates a special serrated tip that is essential to proper installation.



THREAD ADAPTION KIT SELECTION

THREAD SIZE	THREAD ADAPTION KIT	THREAD ADAPTION KIT
6-32 UNC	NPT632TAK	AKPT632TAK
8-32 UNC	NPT832TAK	AKPT832TAK
10-32 UNF	NPT1032TAK	AKPT1032TAK
1/4-20 UNC	NPT420TAK	AKPT420TAK
5/16-18 UNC	NPT518TAK	AKPT518TAK
3/8-16 UNC	NPT616TAK	AKPT616TAK
M4 x 0,7 ISO	NPT470TAK	AKPT470TAK
M5 x 0,8 ISO	NPT580TAK	AKPT580TAK
M6 x 1,0 ISO	NPT610TAK	AKPT610TAK
M8 x 1,25 ISO	NPT8125TAK	AKPT8125TAK
M10 x 1,50 ISO	NPT1015TAK	AKPT1015TAK

POWER TOOL FEATURES - BENEFITS

- No air lines.
- Existing AVK TAK's easily installed/removed.
- Sets M4 - M10/#6 - 3/8" inserts, and M4 - M6/#6 - 1/4" studs.
- Ergonomics better than typical installation tools - no wrist torque, balanced better.
- Quieter than air tools.
- Process security- audible and visual verification.
- Bright LED to illuminate installation hole.
- Incrementally adjustable (90 settings) within five sizes either English or Metric.
- Good (IO)/No Good (NO) electric readout after each install.
- Battery "Brain"- RFID chip prevents overcharging and monitors energy level stopping any action at 20% of battery life - No dropping off of power- No loose inserts.
- Installation is controlled electrically- not mechanically.
- After 1.5 million cycles tested no drop in Torque readings.
- One charge sets from 200 to 400 inserts depending on material.
- Single trigger operation.



Get quote >>

Angic Global Solutions

1-888-872-0690

39

<https://www.AngicGlobal.com> Sales@AngicGlobal.com



AVK CVI™ (Cloud Verification Installation) INSERT TOOL - AVK6000

Cloud data collection, torque installation, tool adjustment and programmability of your tool by way of wireless connective links are at AVK for you!

Concerned about proper torque installation and confirmation of data to your customer, try the AVK CVI™ Cloud Verification Installation Tool to resolve your assembly concerns. Our CVI™ System will allow you to monitor and adjust up to 10 tools from your workstation or laptop with digital accuracy.

Rest assured that your CVI™ tool will have plenty of power for installation with the on board 20 volt battery. Ergonomic's is assured by a light weight 4.35 pound tool with a high impact composite body for durability. Our CVI™ tool is the perfect blend of cloud technology and a precision installation battery tool.

TOOL FEATURES - BENEFITS

- CVI™ uses standard AVK / TAK's and special adaption kits are available as well. Contact an AVK Sales Representative.
- Will set all AVK products with the exception of R-N Rivet Nuts and CS™ Series Inserts.
- User friendly display module displays results and accepts programming inputs.
- Up to 8 user-programmable fastening configurations.
- Stores cycle data for up to 1,200 run downs.
- Ergonomic, 4.35 pounds (2kg.)
- Well balanced for ease of handling.
- Wireless communication option delivers process control with I/O, automatic configuration switching and real-time data archiving via Process Communication Module (PCM).
- Control 10 tools, verify torque installation and gather installation data via your work station or laptop.
- Programmable torque, angle and speed settings.
- Brushless motor tested beyond a million cycles.
- Super bright LED headlight with programmable on/off.
- Two 20V battery option provides maximum runtime.



Digital backlit display module displays results and offers quick set-up



Using ICS software and a USB cable connection you can program or download data from the tool with



Wireless communication option allows up to 10 tools to be connected to one PCM for data logging.

AVK HAND TOOL SPECIFICATIONS



HAND TOOLS

The tools shown on this page are engineered to install AVK's...



EXPENDABLE TOOLS

The following expendable tools are ideal for field repairs or consumer installation of AVK's products. Thread the AVK fastener onto the tool mandrel all the way up. Hold the tool with a box wrench and turn the mandrel with another box wrench or ratchet wrench until the AVK fastener is installed

A-K, A-L, A-P, AND A-O SERIES 1st AND 2nd GRIP PRODUCT MODEL AA184		A-T AND A-W SERIES STANDARD PRODUCT MODEL AAT916	
THREAD SIZE	TOOL PART NO.	THREAD SIZE	TOOL PART NO.
4-40 UNC	N/A	4-40 UNC	AAT916-440
6-32 UNC	AA184-632	6-32 UNC	AAT916-632
8-32 UNC	AA184-832	8-32 UNC	AAT916-832
10-24 UNC	AA184-1024	10-24 UNC	AAT916-1024
10-32 UNF	AA184-1032	10-32 UNF	AAT916-1032
1/4-20 UNC	AA184-420	1/4-20 UNC	AAT916-420
5/16-18 UNC	AA184-518	5/16-18 UNC	AAT916-518
3/8-16 UNC	AA184-616	3/8-16 UNC	AAT916-616
1/2-13 UNC	AA184-813	1/2-13 UNC	AAT916-813
M3 x 0,5 ISO	N/A	M3 x 0,5 ISO	AAT916-350
M4 x 0,7 ISO	AA184-470	M4 x 0,7 ISO	AAT916-470
M5 x 0,8 ISO	AA184-580	M5 x 0,8 ISO	AAT916-580
M6 x 1,0 ISO	AA184-610	M6 x 1,0 ISO	AAT916-610
M8 x 1,25 ISO	AA184-8125	M8 x 1,25 ISO	AAT916-8125
M10 x 1,5 ISO	AA184-1015	M10 x 1,5 ISO	AAT916-1015
M12 x 1,75 ISO	AA184-12175	M12 x 1,75 ISO	AAT916-12175

AA184

AAT916

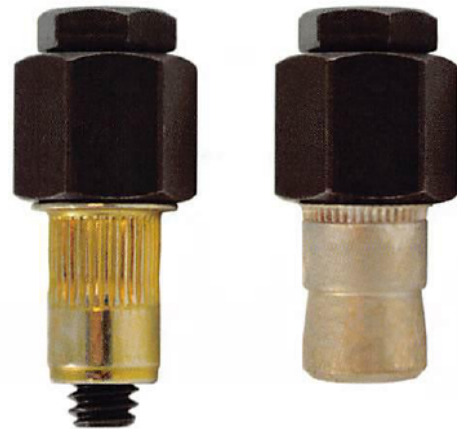

AA170 PLIER TOOL

The AA170 tool is ideal for prototyping or making repairs with the A-K, A-L, A-H, A-P, A-O, E-L and E-H Series threaded inserts.



INSTALLATION:

- Thread AVK part onto tool.
- Place into Hole
- Squeeze handles.

THREAD SIZE	CONVERSION KIT
6-32 UNC	AA271-632
8-32 UNC	AA271-832
10-24 UNC	AA271-1024
10-32 UNF	AA271-1032
1/4-20 UNC	AA271-420
5/16-18 UNC	AA271-518*
3/8-16 UNC	AA271-616*
M4 x 0,7 ISO	AA271-470
M5 x 0,8 ISO	AA271-580
M6 x 1,0 ISO	AA271-610
M8 x 1,25 ISO	AA271-8125*
M10 x 1,5 ISO	AA271-1015*

*These sizes cannot be used with 2nd grip AVK fasteners

AA112 HI-TORQUER™

The AA112 is ideal for prototyping or making repairs with the A-T and A-W Series threaded inserts. It features a patented Quick Change thread size nose assembly.



INSTALLATION:

- Thread insert fully onto mandrel.
- Place into hole.
- Hold grip bar while turning the "T" handle clockwise until insert is installed.
- Turn "T" handle counter clockwise to remove from insert.

THREAD SIZE	CONVERSION KIT
4-40 UNC	AAT202-440
6-32 UNC	AAT202-632
8-32 UNC	AAT202-832
10-24 UNC	AAT202-1024
10-32 UNF	AAT202-1032
1/4-20 UNC	AAT202-420
5/16-18 UNC	AAT202-518
3/8-16 UNC	AAT202-616
M3 x 0,5 ISO	AAT202-350
M4 x 0,7 ISO	AAT202-470
M5 x 0,8 ISO	AAT202-580
M6 x 1,0 ISO	AAT202-610
M8 x 1,25 ISO	AAT202-8125
M10 x 1,5 ISO	AAT202-1015



Get quote >>

Angic Global Solutions

1-888-872-0690

<https://www.AngicGlobal.com> Sales@AngicGlobal.com



AVK HAND TOOL SPECIFICATIONS

The hand tools shown on this page are used to install AVK's...

HAND TOOLS



AA480N & AA510N NEW "WRENCH-LESS" QUICK-RELEASE CONVERSION KIT

To provide a more user friendly manual tool for our marketplace, AVK's AA480N and AA510N installation hand tools now incorporate a new "Wrench-Less" quick-release conversion kit. AVK will continue to support pre-existing tools not utilizing this new conversion kit. When ordering conversion kits and mandrels for pre-existing tools, remove the "N" from the part number shown in the chart below. Please contact an AVK Sales Representative for additional design change clarification.



AA480N DOUBLE ACTION LEVER TOOL

The AA480N tool features a visual stroke indicator and a convenient spin-off removal knob. This tool installs the full range of AVK's spinwall technology product in steel and aluminum and limited sizes of steel and aluminum rivet nuts. See chart below.

INSTALLATION:

- Set the appropriate stroke per the AVK tool instruction sheet.
- Thread product fully onto tool mandrel.
- Place into the hole in your parent material.
- Squeeze tool handles together until product is fully collapsed.
- Spin center knob counter-clockwise unthreading tool mandrel from installed product.



AA510N PLUNGER-DOUBLE ACTION LEVER TOOL

The AA510N tool features a visual stroke indicator and a quick acting pull to remove plunger. Due to its larger size, this tool installs the full range of AVK's Spinwall Technology™ Threaded Insert Product in all materials and various steel and aluminum rivet nuts. See chart below.

INSTALLATION:

- Set the appropriate stroke per the AVK tool instruction sheet.
- Withdraw plunger from tool.
- Hold product over tool mandrel while pushing plunger into tool fully threading product onto the tool mandrel.
- Place into hole in your parent material.
- Squeeze tool handles together until product is fully collapsed.
- Pull plunger from tool unthreading mandrel from installed product.



• Denotes the product can be installed with the AA480N tool. + Denotes the product can be installed with the AA510N tool.

THREAD SIZE	INSERT MATERIAL		A-L, A-K, A-H, A-P, A-O SERIES INSERTS		INSERT MATERIAL		R-N, E-L, E-H, A-R* SERIES RIVET NUTS		STUD MATERIAL	A-S SERIES STUDS	
	STEEL	ALUM	CONVERSION KIT#	REPLACEMENT MANDREL#	STEEL	ALUM	CONVERSION KIT#	REPLACEMENT MANDREL#	STEEL	CONVERSION KIT#	REPLACEMENT MANDREL#
4-40 UNC			N/A	N/A	• +	• +	AA483-440N	18AA481-440N		N/A	N/A
6-32 UNC	• +	• +	AA481-632N	18AA481-632N	• +	• +	AA483-632N	18AA481-632N	•	AA485-632N	18AA485-632N
8-32 UNC	• +	• +	AA481-832N	18AA481-832N	• +	• +	AA483-832N	18AA481-832N	•	AA485-832N	18AA485-832N
10-24 UNC	• +	• +	AA481-1024N	18AA481-1024N	• +	• +	AA483-1024N	18AA481-1024N	•	AA485-1024N	18AA485-1024N
10-32 UNF	• +	• +	AA481-1032N	18AA481-1032N	• +	• +	AA483-1032N	18AA481-1032N	•	AA485-1032N	18AA485-1032N
1/4-20 UNC	• +	• +	AA481-420N	18AA481-420N	• +	• +	AA483-420N	18AA481-420N	•	AA485-420N	18AA485-420N
5/16-18 UNC	• +	• +	AA481-518N	18AA481-518N	• +	• +	AA483-518N	18AA481-518N	•	AA485-518N	18AA485-518N
3/8-16 UNC	• +	• +	AA481-616N	18AA481-616N		• +	AA483-616N	18AA481-616N	•	AA485-616N	18AA485-616N
1/2-13 UNC	• +	• +	AA481-813N	18AA481-813N			N/A	N/A		N/A	N/A
M3 x 0,5 ISO			N/A	N/A	• +	• +	AA483-350N	18AA481-350N		N/A	N/A
M4 x 0,7 ISO	• +	• +	AA481-470N	18AA481-470N	• +	• +	AA483-470N	18AA481-470N	•	AA485-470N	18AA485-470N
M5 x 0,8 ISO	• +	• +	AA481-580N	18AA481-580N	• +	• +	AA483-580N	18AA481-580N	•	AA485-580N	18AA485-580N
M6 x 1,0 ISO	• +	• +	AA481-610N	18AA481-610N	• +	• +	AA483-610N	18AA481-610N	•	AA485-610N	18AA485-610N
M8 x 1,25 ISO	• +	• +	AA481-8125N	18AA481-8125N	• +	• +	AA483-8125N	18AA481-8125N	•	AA485-8125N	18AA485-8125N
M10 x 1,5 ISO	• +	• +	AA481-1015N	18AA481-1015N		• +	AA483-1015N	18AA481-1015N	•	AA485-1015N	18AA485-1015N
M12 x 1,75 ISO	• +	• +	AA481-12175N	18AA481-12175N			N/A	N/A		N/A	N/A

NOTE: Additional UNF fine thread sizes are available. Contact an AVK Sales Representative for details.

WARNING: Failure to adjust the appropriate stroke setting per the AVK tool instruction sheet may damage the tool.

*Contact AVK Sales Representative for details on Conversion Kit and Mandrel Data



AVK KIT SPECIFICATIONS



The Master Assortment Kits shown on this page have been designed for prototype, maintenance and repair applications.

A-L SERIES INSERT MASTER ASSORTMENT KITS

The A-L Series Kit is ideal for prototype and maintenance repair applications. The rugged hard shell plastic kit contains quantities of the A-L Series threaded inserts and the AA170 plier tool shown on page 40. It also contains a full compliment of thread size conversion kits and instruction label.



INCH SIZE KIT PART NUMBER AVK 2292

THREAD SIZE	INSERT QUANTITY	REFILL PAK PART NUMBER	CONVERSION KIT PART NUMBER
6-32 UNC	50	AALS4T-632-80	AA271-632
8-32 UNC	50	AALS4T-832-80	AA271-832
10-32 UNF	50	AALS4T-1032-130	AA271-1032
1/4-20 UNC	50	AALS4T-420-165	AA271-420
5/16-18 UNC	25	AALS4T-518-150	AA271-518
3/8-16 UNC	25	AALS4T-616-150	AA271-616

METRIC SIZE KIT PART NUMBER AVK 2293

THREAD SIZE	INSERT QUANTITY	REFILL PAK PART NUMBER	CONVERSION KIT PART NUMBER
M4 x 0,7 ISO	50	AALS4T-470-2.0	AA271-470
M5 x 0,8 ISO	50	AALS4T-580-3.3	AA271-580
M6 x 1,0 ISO	50	AALS4T-610-4.2	AA271-610
M8 x 1,25 ISO	25	AALS4T-8125-3.8	AA271-8125
M10 x 1,5 ISO	25	AALS4T-1015-3.8	AA271-1015

A-T SERIES INSERT MASTER ASSORTMENT KITS

The A-T Series master assortment kit is ideal for prototype and maintenance repair applications. The rugged hard shell plastic kit contains quantities of the A-T Series Inserts and the AA112 Hi-torquer tool shown on page 40. It also contains a full compliment of thread size conversion kits and instruction label.



INCH SIZE KIT PART NUMBER AAT312A

THREAD SIZE	INSERT QUANTITY	REFILL PAK PART NUMBER	CONVERSION KIT PART NUMBER
4-40 UNC	50	AAT400-440	AAT202-440
6-32 UNC	50	AAT400-632	AAT202-632
8-32 UNC	50	AAT400-832	AAT202-832
10-32 UNF	50	AAT400-1032	AAT202-1032
1/4-20 UNC	50	AAT400-420	AAT202-420
5/16-18 UNC	25	AAT400-518	AAT202-518

METRIC SIZE KIT PART NUMBER AAT312B

THREAD SIZE	INSERT QUANTITY	REFILL PAK PART NUMBER	CONVERSION KIT PART NUMBER
M3 x 0,5 ISO	50	AAT400-350	AAT202-350
M4 x 0,7 ISO	50	AAT400-470	AAT202-470
M5 x 0,8 ISO	50	AAT400-580	AAT202-580
M6 x 1,0 ISO	50	AAT400-610	AAT202-610
M8 x 1,25 ISO	25	AAT400-8125	AAT202-8125



Get quote >>

Angic Global Solutions

1-888-872-0690

<https://www.AngicGlobal.com> Sales@AngicGlobal.com



DESIGN CONSIDERATIONS/APPLICATION CHECKLIST

The following BEST PRACTICE information should be considered to insure proper application design when using AVK fasteners. If you have any application questions, please contact an AVK Sales Representative.

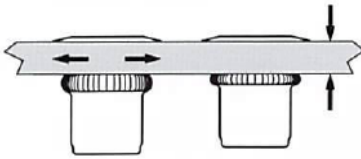

PARENT MATERIAL

The parent material should be dense enough to support the hole fill and clamp load applied by the AVK fastener during installation. Its thickness should be within the grip range of the AVK fastener. Experimentation is suggested to determine optimum fastener selection for plastics.

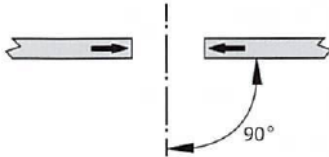

HOLE SIZE

The hole produced in the parent material should be per the AVK catalog specifications. Tolerance for paint or coating buildup should be included to avoid an undersized hole condition. The hole should be square to the parent material. Care should be taken if utilizing punched holes. Oversized condition may occur on breakout side of parent material.

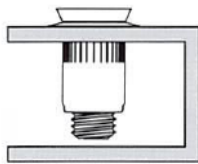

AVK PART ACCESS

The AVK fastener head should sit flat on the parent material. An obstruction to the tail of the AVK product or to the access of the power tool can be corrected by contacting AVK for alternative fastener designs and tooling configurations. The AVK tool should be held perpendicular to the application to avoid excess mandrel wear.

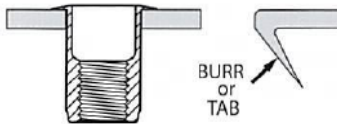

BACKSIDE SURFACE

The backside surface of the parent material should not contain a punch slug or excessive burr that exceeds the grip range of the AVK fastener. Such large obstructions may prohibit the AVK fastener from installing properly.

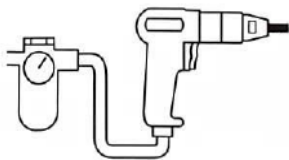

AIR SUPPLY

AVK's Spinwall Technology™ ARO brand installation tools require a pressure range of 60-110 PSI (4,1-7,5 BARS) at 25 S.C.F.M. of volume. Hose and fitting inside diameters need to be a minimum of 5/16 (7,92). An inline oiler and pressure regulator is required. Pressure should be measured as dynamic with the tool running.

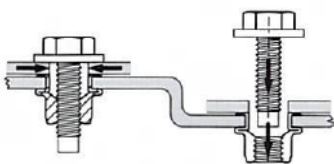

MATING PART HOLE SIZE/ALIGNMENT

The mating part being attached should be non-rotational and contact the head of the AVK fastener. Its hole size should be .040 (1,0) smaller than the head diameter of the AVK fastener. The alignment of the mating part must provide perpendicular entry of the mating fastener into the AVK fastener.

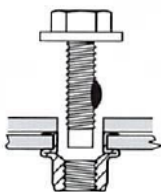

MATING FASTENER

For the A-K, A-L, A-T, A-W and A-O Series the mating fastener should be of a "free-spinning" design and of the grade or class as indicated in this catalog. If a mechanical, chemical locking or prevailing torque element is required, AVK recommends the design selection of the A-H Series in a hex punched hole. Specification of a dog point screw will minimize cross threading and speed the assembly process in any AVK application. Mating screws should be hand started and then power driven to minimize cross threading.

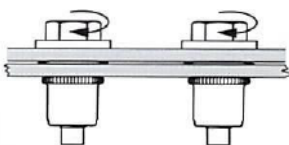

ASSEMBLY TORQUE

For appropriate assembly torques, see the suggested assembly torque data contained on page 44. AVK's products, when used per the data provided in this catalog, have been designed to be compatible with the torque requirements of Grade 5 or Metric Class 8.8/9.8 screws. AVK suggests customer testing to determine the optimum torque due to mating component fit and mating fastener lubrication/finish variations.

AVK TEST DATA



The test data on this page is intended to provide the designer with approximate strength values in various materials and thicknesses. The figures shown are averages of multiple tests. AVK recommends that this data be used only as a guide since various application factors may affect AVK product performance. We recommend testing your application when an exact strength figure is required or the load to be applied comes close to the published data.

Unified (Inch) thread size data is provided in pounds (lbs.) for force and inch pounds (in-lbs.) for torque. Metric data is provided in kilonewtons (kN) for force and newton meters (Nm) for torque.



PULL-OUT is the force required to pull the AVK product from the parent material. The parent material is restrained by a hold down ring 3x the AVK part "D" dim.

PUSH-OUT is the force required to push the AVK product through the parent material. The parent material is supported by a hold down ring 3x the AVK part "D" dim.

SPIN-OUT is the torque required to turn the AVK product in the parent material after installation without influencing clamp load on the AVK product.

ASSEMBLY TORQUE is the amount of torque suggested for Grade 5 or Metric Class 8.8/9.8 mating hardware based on industry standards.

A-L, A-K, A-H, A-S Series product was tested with the -4 finish. R-N Series was Cadmium plated.

THREAD SIZE	PULL-OUT								PUSH-OUT		SPIN-OUT*		ASSEMBLY TORQUE
	IN STEEL SHEET				IN ALUMINUM SHEET				IN STEEL	IN STEEL	IN ALUM		
	.030 in. 0,76 mm	.062 in. 1,57 mm	.090 in. 2,28 mm	.125 in. 3,17 mm	.030 in. 0,76 mm	.062 in. 1,57 mm	.090 in. 2,28 mm	.125 in. 3,17 mm	.125 in. 3,17 mm	.062 in. 1,57 mm	.062 in. 1,57 mm		
A-L / A-K SERIES	6-32	310	850	1570	1830	320	830	1450	1580				12
	8-32	310	850	1570	1830	320	830	1450	1580				22
	10-24	460	1020	1730	2670	440	1000	1700	2380				32
	10-32	460	1020	1730	2670	440	1000	1700	2380				36
	1/4-20	510	1270	2090	3250	490	1180	1920	3020				75
	5/16-18	520	1370	2380	3810	500	1350	2230	3670				156
	3/8-16	520	1370	2380	3810	500	1350	2230	3670				276
	1/2-13		2000	3040	4480		1830	2940	4350				660
	M4	1.4	3.8	7.0	8.1	1.4	3.7	6.5	7.0				2.5
	M5	2.0	4.5	7.7	11.9	2.0	4.5	7.6	10.6				5.0
	M6	2.3	5.7	9.3	14.5	2.2	5.3	8.5	13.4				8.6
	M8	2.3	6.1	10.6	17.0	2.2	6.0	9.9	16.3				21.0
M10	2.3	6.1	10.6	17.0	2.2	6.0	9.9	16.3				42.0	
M12		8.9	13.5	19.9		8.1	13.1	19.4				72.0	
A-H SERIES	6-32	270	660	990	860	270	660	830	840	40	40		12
	8-32	270	660	990	860	270	660	830	840	40	40		22
	10-24	420	990	1670	2520	380	880	1550	2050	80	70		32
	10-32	420	990	1670	2520	380	880	1550	2050	80	70		36
	1/4-20	460	1150	1780	2690	430	1530	2240	3210	130	90		75
	5/16-18	480	1110	1870	2280	460	1050	1680	2890	240	230		156
	3/8-16	480	1110	1870	2280	460	1050	1680	2890	240	230		276
	M4	1.2	2.9	4.4	3.8	1.2	2.9	3.7	3.7	4.5	4.5		2.5
	M5	1.9	4.4	7.4	11.2	1.7	3.9	6.9	9.1	9.0	7.9		5.0
	M6	2.0	5.1	7.9	12.0	1.9	6.8	10.0	14.3	14.7	10.2		8.6
	M8	2.1	4.9	8.3	10.1	2.0	4.7	7.5	12.9	27.1	25.5		21.0
	M10	2.1	4.9	8.3	10.1	2.0	4.7	7.5	12.9	27.1	25.5		42.0
A-S SERIES	6-32	310	850	1570	1830	320	830	1450	1580	630			12
	8-32	310	850	1570	1830	320	830	1450	1580	630			22
	10-24	460	1020	1730	2670	440	1000	1700	2380	580			32
	10-32	460	1020	1730	2670	440	1000	1700	2380	580			36
	1/4-20	510	1270	2090	3250	490	1180	1920	3020	880			75
	5/16-18	520	1370	2380	3810	500	1350	2230	3670	1140			156
	3/8-16	520	1370	2380	3810	500	1350	2230	3670	1160			276
	M4	1.4	3.8	7.0	8.1	1.4	3.7	6.5	4.4	2.7			2.5
	M5	2.0	4.5	7.7	11.9	2.0	4.5	7.6	10.6	2.5			5.0
	M6	2.3	5.7	9.3	14.5	2.2	5.3	8.5	13.4	3.8			8.6
	M8	2.3	6.1	10.6	17.0	2.2	6.0	9.9	16.3	5.0			21.0
	M10	2.3	6.1	10.6	17.0	2.2	6.0	9.9	16.3	5.1			42.0
R-N SERIES	1/4-20	350	860	1770		400	850	2100		2000	100	60	75
	5/16-18	580	1210	2010		540	1110	2244		2690	180	110	156
	3/8-16	630	1230	2050		590	1180	2110		3700	320	120	276
	1/2-13	620	1320	2240		780	1390	2643		3880	450	220	660
	M6	1.5	3.7	7.8		1.7	3.7	9.3		8.8	16.8	10.6	8.6
	M8	2.5	5.3	8.9		2.6	2.9	9.9		11.9	30.3	12.7	21.0
	M10	2.7	5.4	9.0		2.6	5.2	9.3		16.4	40.2	13.5	42.0
	M12	2.7	5.8	9.9		3.4	6.1	11.7		17.2	53.3	48.8	72.0

NOTE 1: Ultimate torque testing should be done using actual customer components and mating hardware due to plating/lubrication variables. AVK's fasteners have been designed to exceed the ultimate torque strength of the appropriate grade/class of mating hardware.

NOTE 2: For test data on other AVK products, contact an AVK Sales Representative.

*NOTE 3: R-N Series Spin-out. Test drop values are keyed steel rivet nuts tested in steel plates and keyed aluminum rivet nut tested in 2024-T4 aluminum plates.



Get quote >>

Angic Global Solutions

1-888-872-0690 45

<https://www.AngicGlobal.com> Sales@AngicGlobal.com



DECIMAL EQUIVALENTS & DRILL SIZE CHART

DRILL SIZE	INCH (Dec.)	METRIC (mm)	DRILL SIZE	INCH (Dec.)	METRIC (mm)	DRILL SIZE	INCH (Dec.)	METRIC (mm)	DRILL SIZE	INCH (Dec.)	METRIC (mm)	DRILL SIZE	INCH (Dec.)	METRIC (mm)
80	.0135	.343	50	.0700	1,778	22	.1570	3,988	G	.2610	6,630	31/64	.4844	12,304
79	.0145	.368	49	.0730	1,854	21	.1590	4,039	17/64	.2656	6,746	1/2	.5000	12,700
1/64	.0156	.396	48	.0760	1,930	20	.1610	4,089	H	.2660	6,756	33/64	.5156	13,096
78	.0160	.406	5/64	.0781	1,984	19	.1660	4,216	I	.2720	6,909	17/32	.5312	13,492
77	.0180	.457	47	.0785	1,994	18	.1695	4,305	J	.2770	7,036	35/64	.5469	13,891
76	.0200	.508	46	.0810	2,057	11/64	.1719	4,366	K	.2810	7,137	9/16	.5625	14,288
75	.0210	.533	45	.0820	2,083	17	.1730	4,394	9/32	.2812	7,142	37/64	.5781	14,684
74	.0225	.572	44	.0860	2,184	16	.1770	4,496	L	.2900	7,366	19/32	.5938	15,083
73	.0240	.609	43	.0890	2,261	15	.1800	4,572	M	.2950	7,493	39/64	.6094	15,479
72	.0250	.635	42	.0935	2,375	14	.1820	4,623	19/64	.2969	7,541	5/8	.6250	15,875
71	.0260	.660	3/32	.0938	2,383	13	.1850	4,700	N	.3020	7,671	41/64	.6406	16,271
70	.0280	.711	41	.0960	2,438	3/16	.1875	4,763	5/16	.3125	7,938	21/32	.6562	16,667
69	.0292	.742	40	.0980	2,489	12	.1890	4,801	O	.3160	8,026	43/64	.6719	17,066
68	.0310	.787	39	.0995	2,527	11	.1910	4,851	P	.3230	8,204	11/16	.6875	17,463
1/32	.0312	.792	38	.1015	2,578	10	.1935	4,915	21/64	.3281	8,334	45/64	.7031	17,859
67	.0320	.813	37	.1040	2,642	9	.1960	4,978	Q	.3320	8,433	23/32	.7188	18,258
66	.0330	.838	36	.1065	2,705	8	.1990	5,055	R	.3390	8,611	47/64	.7344	18,654
65	.0350	.889	7/64	.1094	2,779	7	.2010	5,105	11/32	.3438	8,733	3/4	.7500	19,050
64	.0360	.914	35	.1100	2,794	13/64	.2031	5,159	S	.3480	8,839	49/64	.7656	19,446
63	.0370	.940	34	.1110	2,819	6	.2040	5,182	T	.3580	9,093	25/32	.7812	19,842
62	.0380	.965	33	.1130	2,870	5	.2055	5,220	23/64	.3594	9,129	51/64	.7969	20,241
61	.0390	.991	32	.1160	2,946	4	.2090	5,309	U	.3680	9,347	13/16	.8125	20,638
60	.0400	1,016	31	.1200	3,048	3	.2130	5,410	3/8	.3750	9,525	53/64	.8281	21,034
59	.0410	1,041	1/8	.1250	3,175	7/32	.2188	5,558	V	.3770	9,576	27/32	.8438	21,433
58	.0420	1,067	30	.1285	3,264	2	.2210	5,613	W	.3860	9,804	55/64	.8594	21,829
57	.0430	1,092	29	.1360	3,454	1	.2280	5,791	25/64	.3906	9,921	7/8	.8750	22,225
56	.0465	1,181	28	.1405	3,569	A	.2340	5,944	X	.3970	10,084	57/64	.8906	22,621
3/64	.0469	1,191	9/64	.1406	3,571	15/64	.2344	5,954	Y	.4040	10,262	29/32	.9062	23,017
55	.0520	1,321	27	.1440	3,658	B	.2380	6,045	13/32	.4062	10,317	59/64	.9219	23,416
54	.0550	1,397	26	.1470	3,734	C	.2420	6,147	Z	.4130	10,490	15/16	.9375	23,813
53	.0595	1,511	25	.1495	3,797	D	.2460	6,248	27/64	.4219	10,716	61/64	.9531	24,209
1/16	.0625	1,588	24	.1520	3,861	1/4	.2500	6,350	7/16	.4375	11,113	31/32	.9688	24,608
52	.0635	1,613	23	.1540	3,912	E	.2500	6,350	29/64	.4531	11,509	63/64	.9844	25,004
51	.0670	1,702	5/32	.1562	3,967	F	.2570	6,528	15/32	.4688	11,908	1	1.000	25,400

DECIMAL EQUIVALENT OF STANDARD GAUGE SHEET ALUMINUM & SHEET METAL

NO. OF GAUGE	GAUGE		NO. OF GAUGE	GAUGE		NO. OF GAUGE	GAUGE	
	ALUM (B&S)	STEEL (US STD.)		ALUM (B&S)	STEEL (US STD.)		ALUM (B&S)	STEEL (US STD.)
10	.1019	.1345	17	.0453	.0538	24	.0201	.0239
11	.0907	.1196	18	.0403	.0478	25	.0179	.0209
12	.0808	.1046	19	.0359	.0418	26	.0159	.0179
13	.0720	.0897	20	.0320	.0359	27	.0142	.0164
14	.0641	.0747	21	.0285	.0329	28	.0126	.0149
15	.0571	.0673	22	.0253	.0299	29	.0113	.0135
16	.0508	.0598	23	.0226	.0269	30	.0100	.0120

SUGGESTED ASSEMBLY TORQUE VALUES TO PRODUCE CORRESPONDING BOLT LOADS

THREAD SIZE	SAE GRADE 5 BOLTS		
	CLAMP LOAD	ASSY TORQUE - DRY	ASSY TORQUE - PLATED
#4-40	380 lbs.	8 in.-lbs.	6 in.-lbs.
#6-32	580 lbs.	16 in.-lbs.	12 in.-lbs.
#8-32	900 lbs.	30 in.-lbs.	22 in.-lbs.
#10-24	1120 lbs.	43 in.-lbs.	32 in.-lbs.
#10-32	1285 lbs.	49 in.-lbs.	36 in.-lbs.
1/4-20	2000 lbs.	96 in.-lbs.	75 in.-lbs.
1/4-28	2300 lbs.	120 in.-lbs.	86 in.-lbs.
5/16-18	3350 lbs.	204 in.-lbs.	156 in.-lbs.
5/16-24	3700 lbs.	228 in.-lbs.	168 in.-lbs.
3/8-16	4950 lbs.	360 in.-lbs.	276 in.-lbs.
3/8-24	5600 lbs.	420 in.-lbs.	300 in.-lbs.

METRIC CONVERSIONS

LINEAR	Multiply INCHES by 25.4 to get MILLIMETERS (mm)	Multiply MILLIMETERS (mm) by .03937 to get INCHES
	Multiply FEET by 0.3048 to get METERS (m)	Multiply METERS (m) by 3.281 to get FEET
	Multiply INCHES by 2.54 to get CENTIMETERS (cm)	Multiply CENTIMETERS (cm) by .3937 to get INCHES
TORQUE	Multiply INCH-POUNDS by 0.11298 to get NEWTON-METERS (Nm)	Multiply NEWTON-METERS (Nm) by 8.851 to get INCH-POUNDS
	Multiply FOOT-POUNDS by 1.3558 to get NEWTON-METERS (Nm)	Multiply NEWTON-METERS (Nm) by 0.7376 to get FOOT-POUNDS
FORCE	Multiply POUNDS by .00445 to get KILONEWTONS (kN)	Multiply KILONEWTONS (kN) by 224.72 to get POUNDS
PRESSURE	Multiply PSI by .069 to get BARS	Multiply BARS by 14.5 to get PSI

TROUBLE SHOOTING

SYMPTOM	CHECK LIST
1. Tool does not operate.	Air lines clear? Tool inlet clear? Tool exhaust clear? Motor Lubrication?
2. Tool runs but stalls before product is installed.	Proper tool RPM for thread size being used? Adequate air pressure with tool running? TAK bearing in place and lubricated? Damaged mandrel? Wrong grip part?
3. Tool strips product threads.	Proper tool RPM for thread size being used? Too much air pressure? Has the mandrel worn too small?
4. Mandrels wear/break.	Is there too much air pressure? Is the tool being held perpendicular during installation?



PLATING CHART



**PLATING
DATA**

AK, AL, AH, AS, AO, AT, AW, RN, EL, EH & CS SERIES PRODUCT FINISHES

AVK#	TYPE	SPECIFICATION	THICKNESS	COLOR	WHITE CORROSION	RED CORROSION
1	Plain Finish	Plain with clear protective coating		Clear	No Req.	No Req.
2*	Cad Plate/Clear	AMS-QQ-P-416, TY I Class 3, clear and clear protective coating	.0002 min	Silver	No Req.	No Req.
3	Zinc	ASTM-B-633, Fe/Zn 8 μ , with clear protective coating	.0003 min	Silver	12 hrs	No Req.
		AVK SPEC ESP-P-006	.0003 min	Silver	12 hrs	No Req.
3R	Zinc	ASTM-B-633, Fe/Zn 8 μ	.0003 min	Silver	12 hrs	No Req.
		AVK SPEC ESP-P-006	.0003 min	Silver	12 hrs	No Req.
3T	Zinc Trivalent	ASTM-B-633, Fe/Zn 8 μ , with clear protective coating	.0003 min	Silver	72 hrs	No Req.
		AVK SPEC ESP-P-003	.0003 min	Silver	120 hrs	384 hrs
4	Yellow Zinc	ASTM-B-633, Fe/Zn 8 μ , with clear protective coating	.0005 min	Yellow	96 hrs	No Req.
4T	Yellow Zinc Trivalent	ASTM-B-633, Fe/Zn 8 μ , with clear protective coating	.0003 min	Yellow	120 hrs	No Req.
		AVK SPEC ESP-P-002	.0003 min	Yellow	120 hrs	458 - 800 hrs
5*	Dull Tin	MIL-T-10727 TY I with clear protective coating	.0003 min	Gray	No Req.	24 hrs
6*	Silver Plate	QQ-S-365 TY III, Grade A with clear protective coating	.0003 min	Silver	96 hrs	No Req.
7	Cadmium	AMS-QQ-P-416 TY II, class 2 yellow dichromate with clear protective coating	.0003 min	Gold	96 hrs	No Req.
8	Chemical Film	MIL-C 5541 with clear protective coating	Film	No Color Specified	120 hrs	No Req.
9	Yellow Tin Zinc	BPS-TZ-327 8 μ , with clear protective coating	.0003 min	Dull Gold	120 hrs	300 hrs
		AVK SPEC ESP-P-007	.0003 min	Dull Gold	120 hrs	300 hrs
9A	Yellow Tin Zinc	BPS-TZ-327 10 μ , with clear protective coating	.0004 min	Dull Gold	120 hrs	400 hrs
		AVK SPEC ESP-P-007 (9A)	.0004 min	Dull Gold	120 hrs	400 hrs
9B	Yellow Tin Zinc	BPS-TZ-327 12 μ , with clear protective coating	.0005 min	Dull Gold	120 hrs	500 hrs
		AVK SPEC ESP-P-007 (9B)	.0005 min	Dull Gold	120 hrs	500 hrs
9T*	Tin Zinc Trivalent	ESP-P-004 8 μ , with clear protective coating	.0003 min	Silver	120 hrs	500 - 800 hrs
10	Zinc Nickel	BPS-TZ-427 8 μ , with clear protective coating	.0003 min	Silver	240 hrs	1000 hrs

Note 1: All of these finishes may be applied to any of the products listed at the top of the above chart.

Note 2: *These finishes minus the clear protective coating can be applied to our AT and AW series products.

Note 3: AVK reserves the right to substitute Trivalent ("T") finishes as an alternative on orders placed under non ROHS compliant platings.

Example: ALS9T-420-165 may substitute ALS9-420-165

Note 4: All Triv.



Get quote >>

Angic Global Solutions

1-888-872-0690 47

<https://www.AngicGlobal.com> Sales@AngicGlobal.com



AVK INDUSTRIAL PRODUCTS

AVK Industrial Products, a Precision Castparts Company, produces all of its blind threaded captive fasteners at its factory in Southern California which is located just miles northwest of downtown Los Angeles. We have been manufacturing high quality blind threaded captive fasteners for over 30 years.

AVK FASTENERS ARE MADE IN THE U.S.A

AVK's Quality Management System is registered to ISO/TS16949 and ISO9001
AVK's Environmental Management System is registered to ISO14001

A-L Series, A-K Series, A-H Series, A-R Series, A-S Series, A-T Series, A-O Series, R-N Series, E-L Series, E-H Series, Composi-Sert, C-S Series, C-L Series, One-Set, OST, PreSet, SPP2 Tool, SPP3 Tool Data Master, CVI, Hi-Torquer, "Improving The Way We Assemble The World," and Spinwall Technology are Trademarks of Avibank Mfg., Inc.
A-W Series, AVK and  are Registered Trademarks of Avibank Mfg., Inc. Lubriplate is a registered trademark of Lubriplate Lubricants Co.

AVK sells its products through Authorized Distributors which are supported by AVK's Factory-Trained Field Sales Staff. For additional information contact your local AVK Distributor or contact an AVK Sales Representative.

DISTRIBUTED BY:



AVK INDUSTRIAL PRODUCTS

A **POC** COMPANY

25323 RYE CANYON ROAD, VALENCIA, CALIFORNIA 91355-1271
TELEPHONE: 661-257-2329 FAX: 661-257-8043 WEBSITE: www.avkfasteners.com

AVK RESERVES THE RIGHT TO CHANGE PRODUCT SPECIFICATIONS TO IMPLEMENT QUALITY IMPROVEMENTS OR PART PERFORMANCE.
SPECIFICATIONS PROVIDED PRIOR TO APRIL 2013 HAVE BEEN UPDATED IN THIS CATALOG.



Get quote 

ENGINEERING MANU

Angic Global Solutions

1-888-872-0690

<https://www.AngicGlobal.com> Sales@AngicGlobal.com



AVK INDUSTRIAL PRODUCTS

A **PCC** COMPANY

MARKET LEADER IN BLIND THREADED INSERTS AND STUDS

Quality Management System is registered to ISO9001:2015

Environmental Management System is registered to ISO9001:2015

Automotive Quality Management System is registered to IAF 16949:2016



Get quote >>

ment. All stand
Non-RoHS comp

Angic Global Solutions

<https://www.AngicGlobal.com>

1-888-872-0690

Sales@AngicGlobal.com



BLIND INSTALLED THREADED INSERTS AND STUDS

A blind installed threaded fastener is defined as a fastener with internal or external threads that can be installed into a panel, tube or other structure from the front side without need to see or access the backside, or "blind" side to complete the installation. Once installed the fastener remains captive to which a mating component can be attached using standard hardware.

SPINWALL TECHNOLOGY™

Spinwall Technology™ ...Sets AVK apart

You will notice throughout this catalog references to the phrase Spinwall Technology™. This phrase describes the philosophy of our product's design, manufacturing and installation systems.

Our Spinwall Technology™ products are manufactured on high-speed, state-of-the-art cold forming equipment on which very precise tolerances are achieved. This capability allows AVK to produce products with unique mechanical and installation properties that result in the AVK product filling the hole prior to backside flange formation. Read more about hole fill and the other advantages of Spinwall Technology™ on the separate product profile pages.

SPINWALL TECHNOLOGY™

HOW HOLE FILL WORKS FOR YOU

As the A-L Series is installed, the knurled body expands 360° **FILLING THE HOLE**. This feature provides exceptional torque strength and vibration resistance.

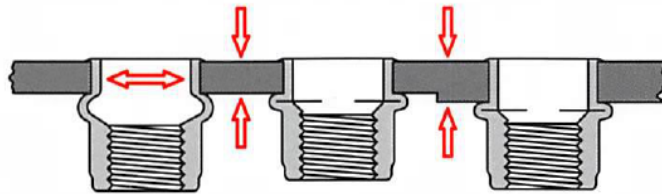

The installation tool then continues to install the insert forming a backside flange even in multiple or variable thickness materials **WITHOUT ADJUSTMENT**.

INSTALLATION SEQUENCE

Here is how the AVK product is installed "blind."

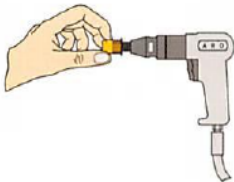

1/4 turn the AVK fastener onto the tool's threaded mandrel.

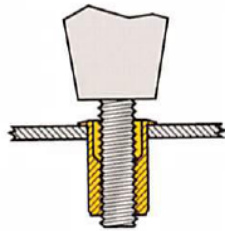

The fastener is placed into the hole.

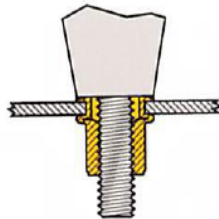

The forward trigger is depressed and the fastener is installed properly.



The reverse trigger is depressed and the tool unthreads from the installed fastener.

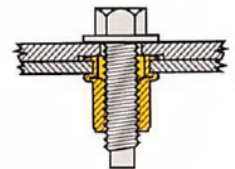

The mating component is then attached using conventional hardware.

ADVANTAGES OF ASSEMBLY WITH AVK

In today's competitive global marketplace it's important that manufacturers seek out new materials and state of the art assembly techniques to maintain market leadership and profits. Consider these opportunities:

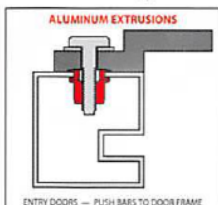

- **LIGHTWEIGHT THINNER GAUGE SHEET METALS** are being specified to reduce raw material and freight cost. AVK provides strong load-bearing threads in these materials.
- **EXTRUDED ALUMINUM** can be formed into complex high-strength shapes that reduce weight. Blind assembly with AVK in extruded aluminum is easy.



- **HYDROFORMED TUBING** is a new developing technology. AVK products are an excellent choice for fastening to hydroformed tubing.
- **GALVANIZED SHEET METAL** provides improved corrosion resistance. Why burn it away with weld nuts and studs? Use AVK. It doesn't damage

- **Plastics** continue to experience growth. AVK's products are especially useful in SMC, rotational or blow molded plastics.
- **PREPAINTED SHEET METAL** can eliminate costly in-plant lines. AVK can be installed into painted surfaces without affecting the surface finish.
- **CONSUMER ASSEMBLY** of products shifts the labor burden to the customer. It's hard to strip or spin AVK products and they make consumer assembly reliable with standard hardware.
- **ENVIRONMENTAL AND SAFETY ISSUES** continue to push manufacturers away from dirty processes such as welding and painting. AVK can help

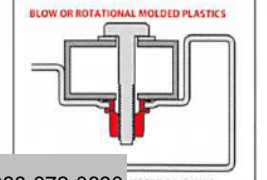
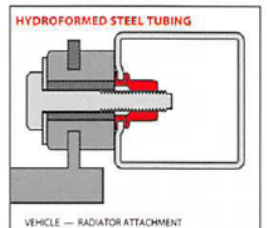

Get quote »

Angic Global Solutions 1-888-872-0690
<https://www.AngicGlobal.com> Sales@AngicGlobal.com

A-RTM
SERIES
INSERT
THREADED INSERT



A-R SERIES INSERT PROFILE

The **A-R Series** threaded insert has been designed for use in plastics and thin gauge sheet metal applications where increased pull-out resistance is required.

The A-R Series features a PreSetTM slotted body design that when installed folds into four segments gripping the backside of the parent material. This design feature allows the A-R Series to be installed into single, variable or multiple thickness materials using AVK's ARO torque-stall pneumatic tools or AVK's pneumatic/hydraulic SPP ToolTM Systems.

A-R Series PreSetTM Design

How it works for you: The preset slightly expanded slotted body design of the A-R Series enables it to be installed using torque type tools.

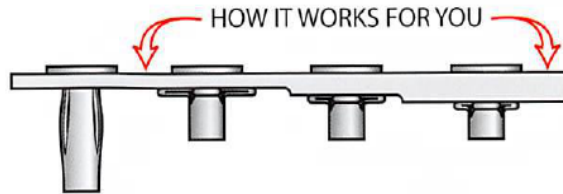

Hand or pneumatic torque tools will install the A-R Series in single, variable or multiple thickness.

DESIGN BENEFITS

- **INSTALLS USING TORQUE** stall type tooling due to the slightly expanded slotted body design. This is important when working with plastics that vary in thickness. No adjustment of the tool is necessary when installing the part into variable thickness materials.
- **INSTALLS USING HAND WRENCHED TORQUE** type tools. Ideal for use in kits and consumer installation applications.
- **PROVIDES EXCEPTIONAL** pull out resistance in soft plastics or thin sheet metal applications even if holes are hand drilled and oversized.
- **SUPERIOR CORROSION RESISTANCE** because all surfaces of the slotted body are plated. Standard plating is zinc/yellow trivalent finish (120 hours to white corrosion). For exceptional corrosion protection we offer a trivalent tin/zinc alloy finish.
- Superior thread strength due to AVK's internal roll threading process.
- **AVAILABLE IN STEEL.**

GLTM
SERIES
COMPRESSION

C-L SERIES COMPRESSION LIMITER

Compression limiters are utilized daily in applications where a compressive load is applied to a composite assembly. The compression limiter distributes and transfers clamp load when the mating bolt or screw is installed into a composite assembly. This distribution of clamp load prevents damage to your assembly and compensates for expansion and contraction of the composite substrate. Thus, the compression limiter will provide consistent joint integrity allowing your joint assembly to remain tight.

Compression limiters are designed specifically for customer's requirements. Call your local AVK Sales Representative and provide your requirements.

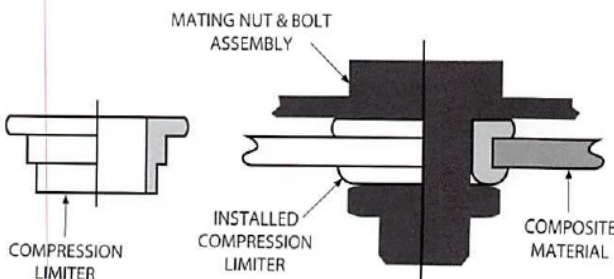

- Compensation for Expansion & Contraction of Composite Material.
- Maintain Joint Stability.
- Protect Composite Material from Damage.
- Reduce Rework from Cracked Assemblies.
- Creates Clean Holes with Alignment Points.
- Reduce Assembly Rejection and Maintain Production Through-Put.
- Excellent for Automotive and Truck Composite

ADDITIONAL PRODUCTS FROM AVK

 <p>RN™ R-N SERIES™ RIVET NUT</p> <ul style="list-style-type: none"> • Thick head and body • Exceptional push-out strength • Ideal for leg-leveling attachments 	 <p>AT™ A-T SERIES™ RIVET NUT</p> <ul style="list-style-type: none"> • Installs in any thickness material • Underhead knurl • Available in stainless steel 	 <p>AW® A-W SERIES™</p> <ul style="list-style-type: none"> • Installs in any thickness material • Full diamond knurl
 <p>AO™ A-O SERIES™</p> <ul style="list-style-type: none"> • Low profile head • Available in steel 	 <p>EL™ E-L METRIC SERIES™ KNURLED THREADED INSERT</p> <ul style="list-style-type: none"> • True metric hole size • Variety of head configuration • Available in closed end type insert 	 <p>EH™ E-H METRIC SERIES™ THREADED HEX INSERT</p> <ul style="list-style-type: none"> • True metric hole size • Variety of head configuration • Available in closed end type insert

A-L Series, A-K Series, A-H Series, A-S Series, A-T Series, A-P Series, A-O Series, A-R Series, SPP and Spinwall Technology are trademarks of Avibank Mfg., Inc. A-W Series, R-N Series, AVK and the AVK logo are registered trademarks of Avibank Mfg., Inc.

INSTALLATION TOOL TYPES



The expendable tool is used for lower consumer cost or field installations.



The lever or plier style tools are used for experimental or field installations.



The pneumatic and battery tool is used for production line work.



Automation system can be used for installations

PUSH TO START - SINGLE ACTION INSTALLATION TOOLS

Single stage trigger for complete thread on and reverse thread off for faster insert installations.



AVK5500



SPP2



AVK 6000



SPP 3 Tool™ Data Master

For more on AVK see our Web Site at www.avkfasteners.com

AVK is Made in the U.S.A.



AVK AUTHORIZED STOCKING DISTRIBUTOR



AVK INDUSTRIAL PRODUCTS

A **PCC** COMPANY

25323 RYE CANYON ROAD, VALENCIA, CALIFORNIA 91355-1271

TELEPHONE: 661-257-2329 FAX: 661-257-8043 WEBSITE: www.avkfasteners.com

AVK RESERVES THE RIGHT TO CHANGE PRODUCT SPECIFICATIONS TO IMPLEMENT QUALITY IMPROVEMENTS OR PART PERFORMANCE.



Get quote »

FEBRUARY 2020
PRODUCT BRO

Angic Global Solutions

1-888-872-0690

<https://www.AngicGlobal.com> Sales@AngicGlobal.com